

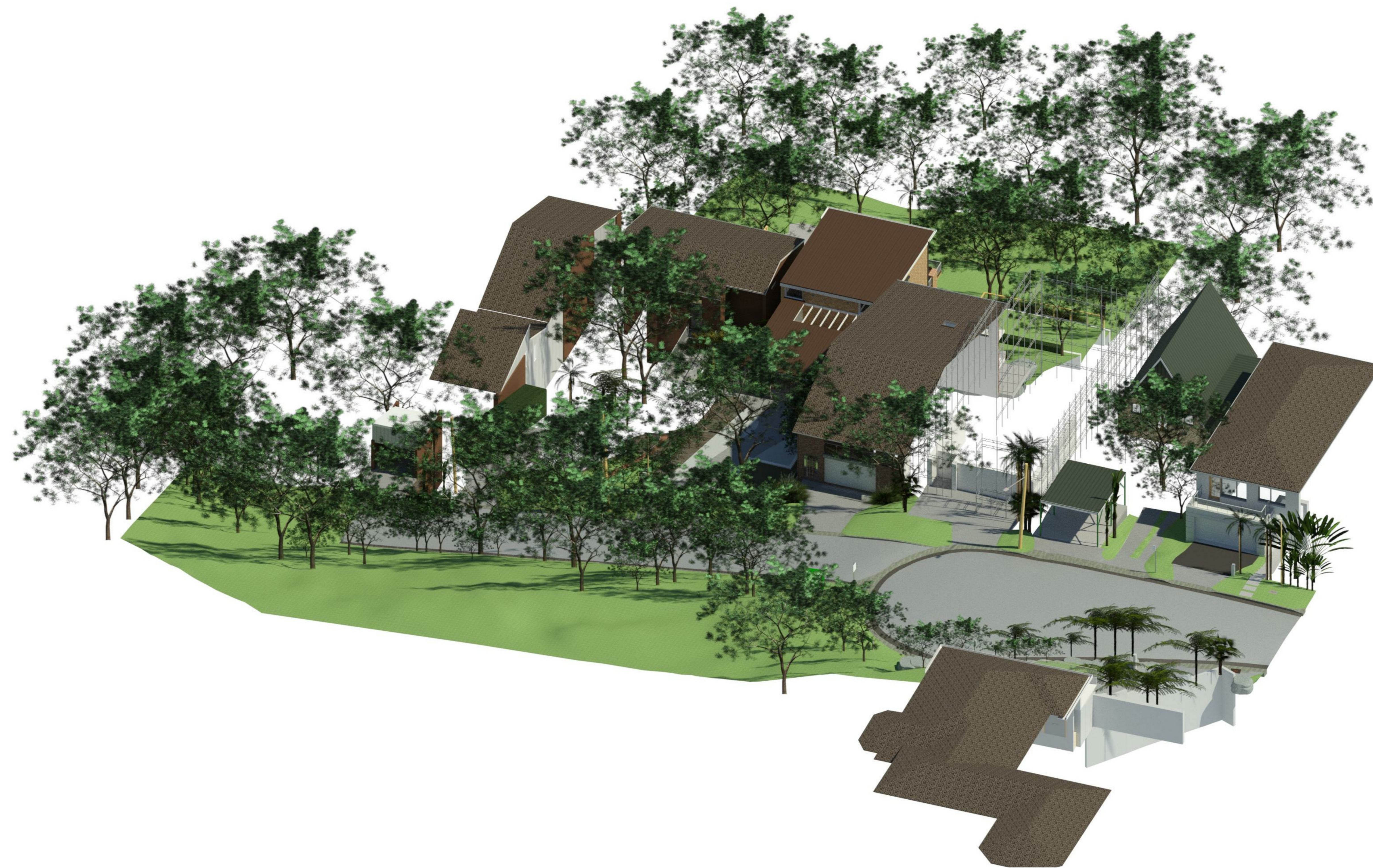

C&A SURVEYORS

ABN: 79160 054 473
E: info@candasurveyors.com.au
W: candasurveyors.com.au

PROJECT NAME:	DETAIL/IDENT SURVEY, FLOOR PLANS, ELEVATIONS & 3D MODEL	REVISION:	1
CLIENT NAME:	SQUILLACE ARCHITECTURE - RYAN	MODELER:	MZ/AH
PROJECT NO.	30921-23	CHECKED BY:	MR
PROJECT ADDRESS:	5 BARRABOOK STREET CLONTAF	ISSUE DATE:	13/11/2023



NOTES: This model is made using a combination of 3D laser scanning and conventional survey instruments. It should be noted that the accuracy of the model is based on the selection made when completing the C & A modeling checklist

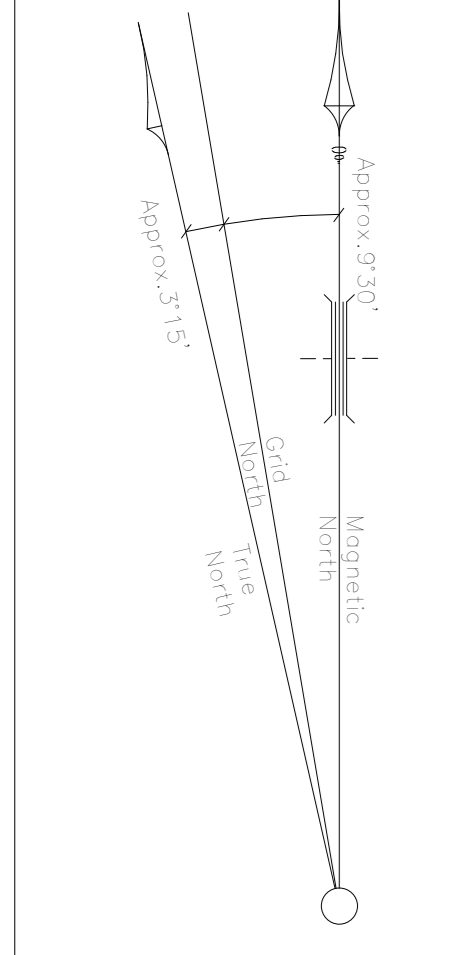

1 MAIN SURVEY PLAN
1 : 100

MARK ANTHONY REID
(REGISTERED SURVEYOR)
SURVEYOR ID No.SU000183

LEGEND:

AHD	AUSTRALIAN HEIGHT DATUM	PAV	PAVERS
AWN	AWNING	PP	POWER POLE
BM	BENCH MARK	RL	REDUCED LEVEL
CONC	CONCRETE	RR	ROOF RIDGE
CS	CONCRETE SURFACE	SC	SERVICE COVER
D/H/S	DIAMETER/HEIGHT/SPREAD	SV	STOP VALVE
D	DOOR	TEL	TELSTRA PIT
EC	EDGE OF CONCRETE	TW	TOP OF WALL
EG	EAVE & GUTTER	TK	TOP OF KERB
FL	FLOOR LEVEL	TW	TOP OF WALL
GDN	GARDEN	V	VALVE
HYD	HYDRANT	VC	VEHICLE CROSSING
IL	INVERT LEVEL	WM	WATER METER
LH	LAMP POLE	WS	WINDOW SILL
NS	NATURAL SURFACE	WT	TOP OF WINDOW

NOTE: THIS SURVEY WAS COMPLETED USING LASER SCANNING TECHNOLOGY AND CONVENTIONAL SURVEY EQUIPMENT. THE DATA WAS ACCURATE AT TIME OF SURVEY.

THIS PLAN AND THE INFORMATION CONTAINED HEREIN REMAINS THE PROPERTY OF C & A SURVEYORS NSW PTY LTD. IT MUST NOT BE COPIED IN WHOLE OR PART, AND IS NOT TO BE USED FOR ANY PURPOSE OTHER THAN FOR THAT WHICH IT HAS BEEN PREPARED. WITHOUT WRITTEN CONSENT OF C & A SURVEYORS NSW PTY LTD. THIS PLAN HAS BEEN PREPARED FOR THE SOLE USE OF THE INSTRUCTING PARTY.

C & A SURVEYORS NSW P/L
Ph: 9630 9299
30 GROSE STREET,
PARRAMATTA NSW 2151
info@candasurveyors.com.au
www.candasurveyors.com.au

DETAIL & IDENTIFICATION SURVEY, FLOOR PLANS, ELEVATIONS & 3D MODEL OF LOT 15 SEC K ON DP2610 AT 5 BARRABOOK STREET CLONTAF

INSTRUCTING PARTY: SQUILLACE ARCHITECTURE - RYAN

Revision No.	Description	Date
01	DETAIL/IDENT SURVEY, FLOOR PLANS, ELEVATIONS & 3D MODEL	13/11/2023
02		
03		
04		

NOTES ON SURVEY

- THE IDENTIFICATION COMPONENT OF THIS SURVEY SHOWING DISTANCES BETWEEN STRUCTURES AS SURVEYED AND CADASTRAL BOUNDARIES HAS BEEN CONDUCTED IN ACCORDANCE WITH CLAUSE 10 OF THE SURVEYING AND SPATIAL INFORMATION REGULATION 2017.
- THE 2D & 3D DETAIL AND MODELLING COMPONENT OF THIS SURVEY HAS BEEN CONDUCTED IN ACCORDANCE WITH CLAUSE 9 OF THE SURVEYING AND SPATIAL INFORMATION REGULATION 2017.

SECOND SCHEDULE (2 NOTIFICATIONS) AS SEARCHED ON 01/11/2023

- RESERVATIONS AND CONDITIONS IN THE CROWN GRANT(S)
- AP494651 MORTGAGE TO MACQUARIE BANK LIMITED

NOTES:

A) SERVICES SHOWN HAVE BEEN DERIVED FROM VISUAL EVIDENCE APPARENT AT THE TIME OF SURVEY. SERVICES MAY EXIST WHICH ARE NOT SHOWN. THE RELEVANT SERVICE AUTHORITY SHOULD BE CONTACTED TO VERIFY THE EXISTENCE AND POSITION OF SERVICES PRIOR TO THE COMMENCEMENT OF ANY CONSTRUCTION OR EXCAVATION.

B) DIAMETER, HEIGHT & SPREAD OF TREES ARE APPROXIMATE ONLY.

C) LEVELS SHOWN ARE OF AUSTRALIAN HEIGHT DATUM.

D) ORIGIN OF LEVELS: FMS3493 RL 40.925 (AHD) CLASS LB

E) USE STATED DIMENSIONS. DO NOT SCALE.

F) THESE NOTES FORM PART OF THIS PLAN AND CANNOT BE REMOVED.

G) NO COVENANTS AND/OR RESTRICTIONS HAVE BEEN INVESTIGATED BY C & A SURVEYORS PTY LTD.

DATUM:	AHD	SURVEYED BY: JG/TJ
SURVEY DATE:	02/11/2023	DRAWN BY: MZ/AH
DATE DRAWN:	03/11/2023	SCALE: 1 : 100 @A0
REFERENCE:	30921-23	SHEET: 2 OF 7



1 GROUND FLOOR
1 : 50

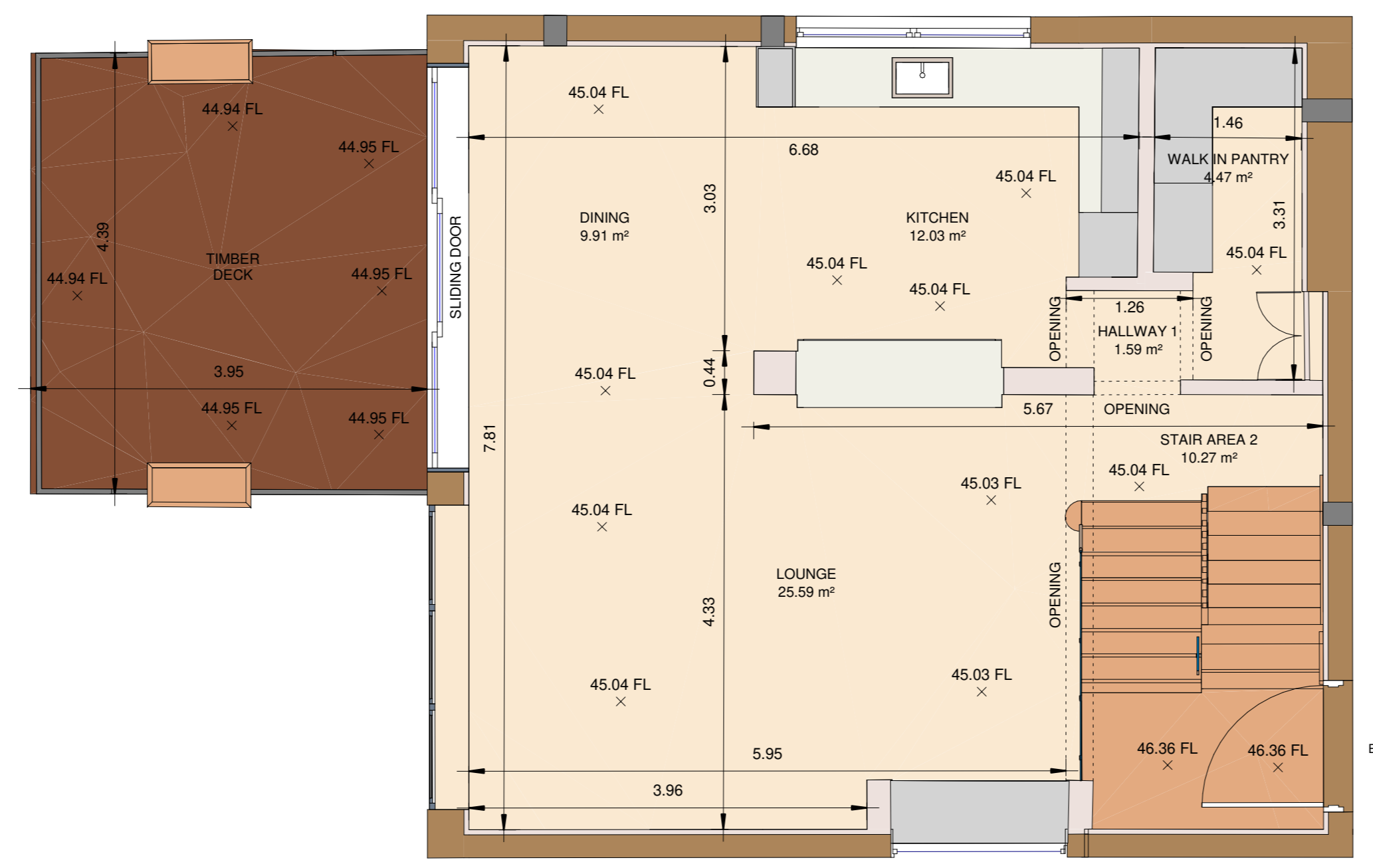

2 FIRST FLOOR
1 : 50



3 SECOND FLOOR
1 : 50

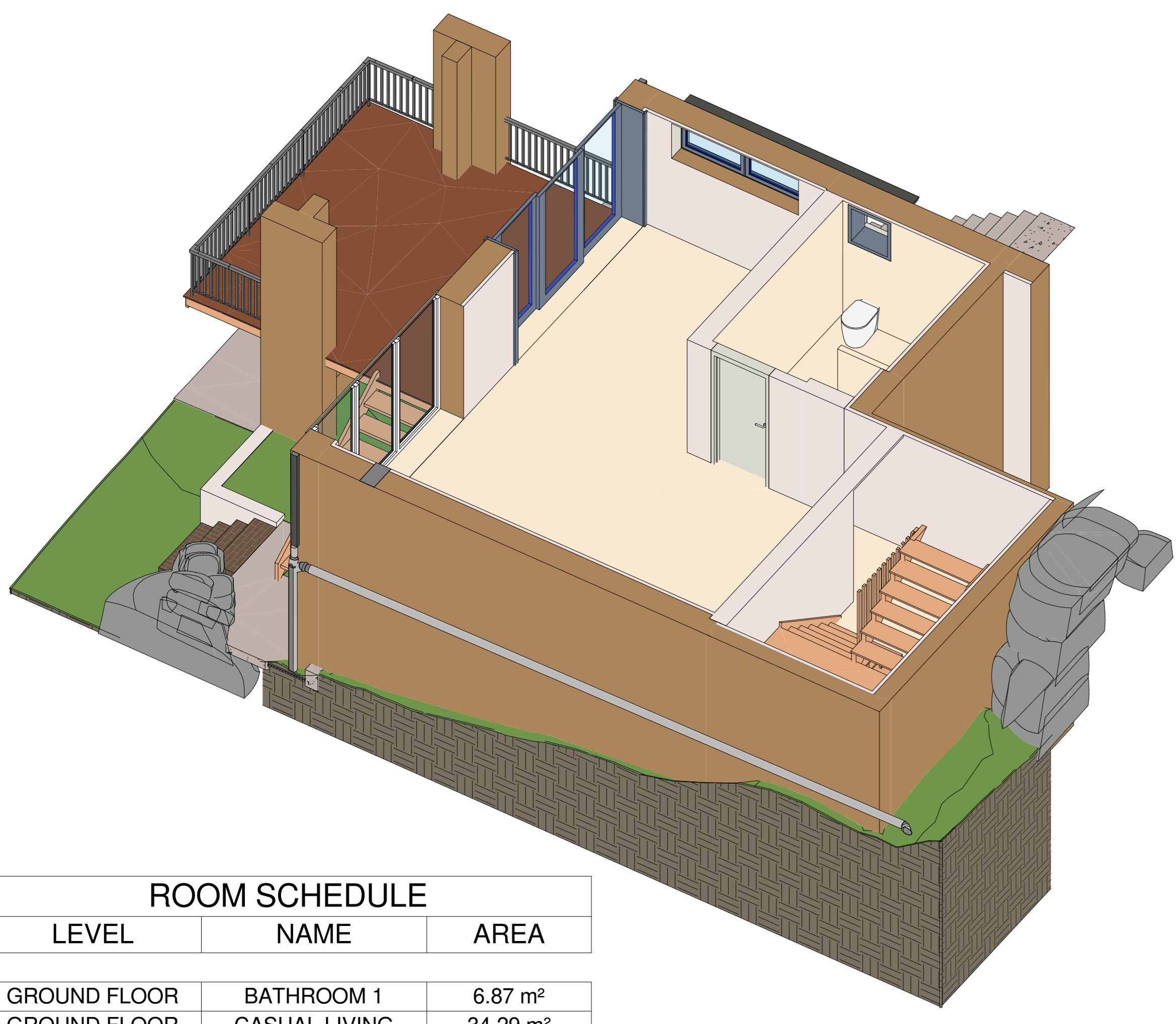

4 GROUND FLOOR 3D VIEW

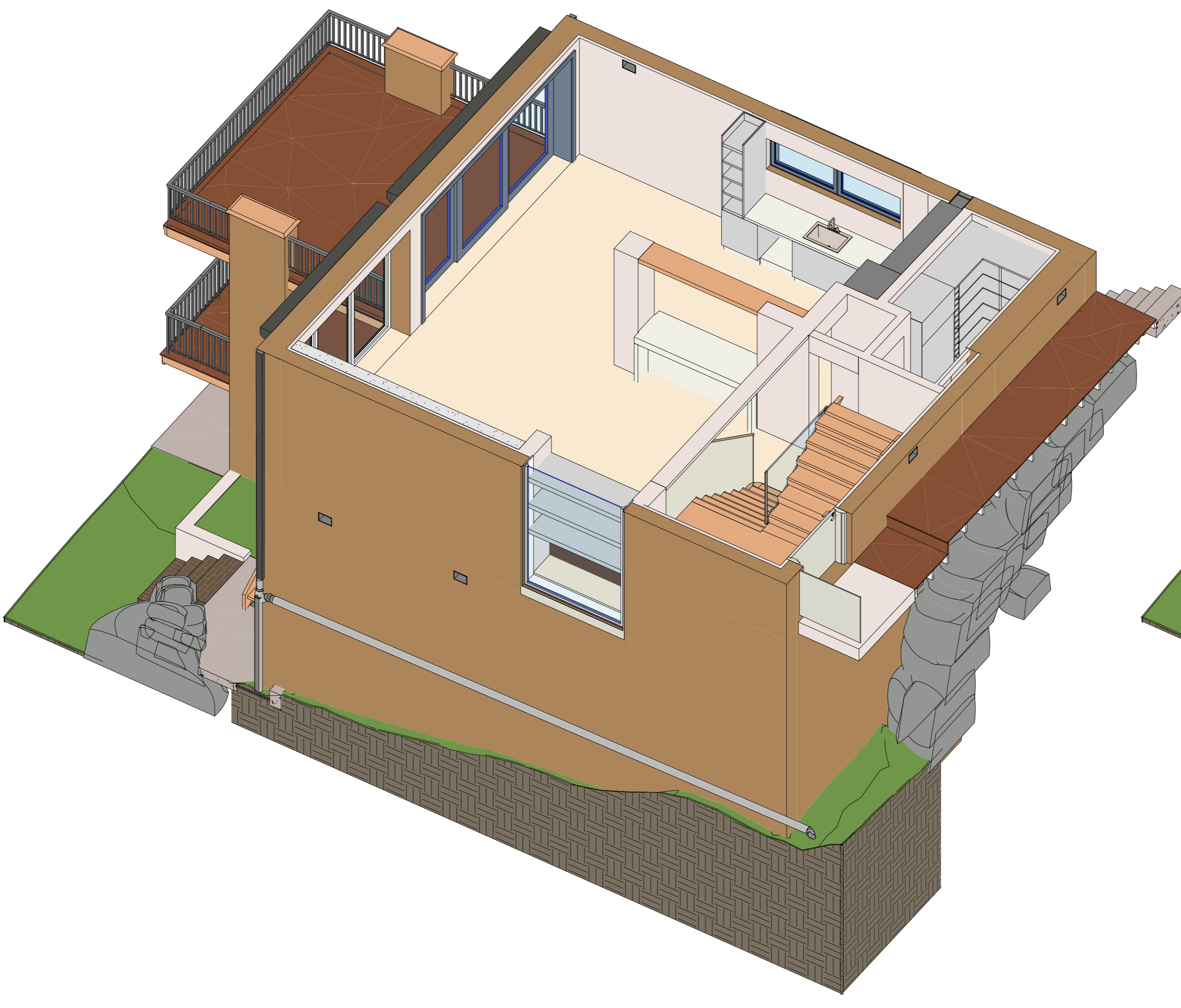

5 FIRST FLOOR 3D VIEW

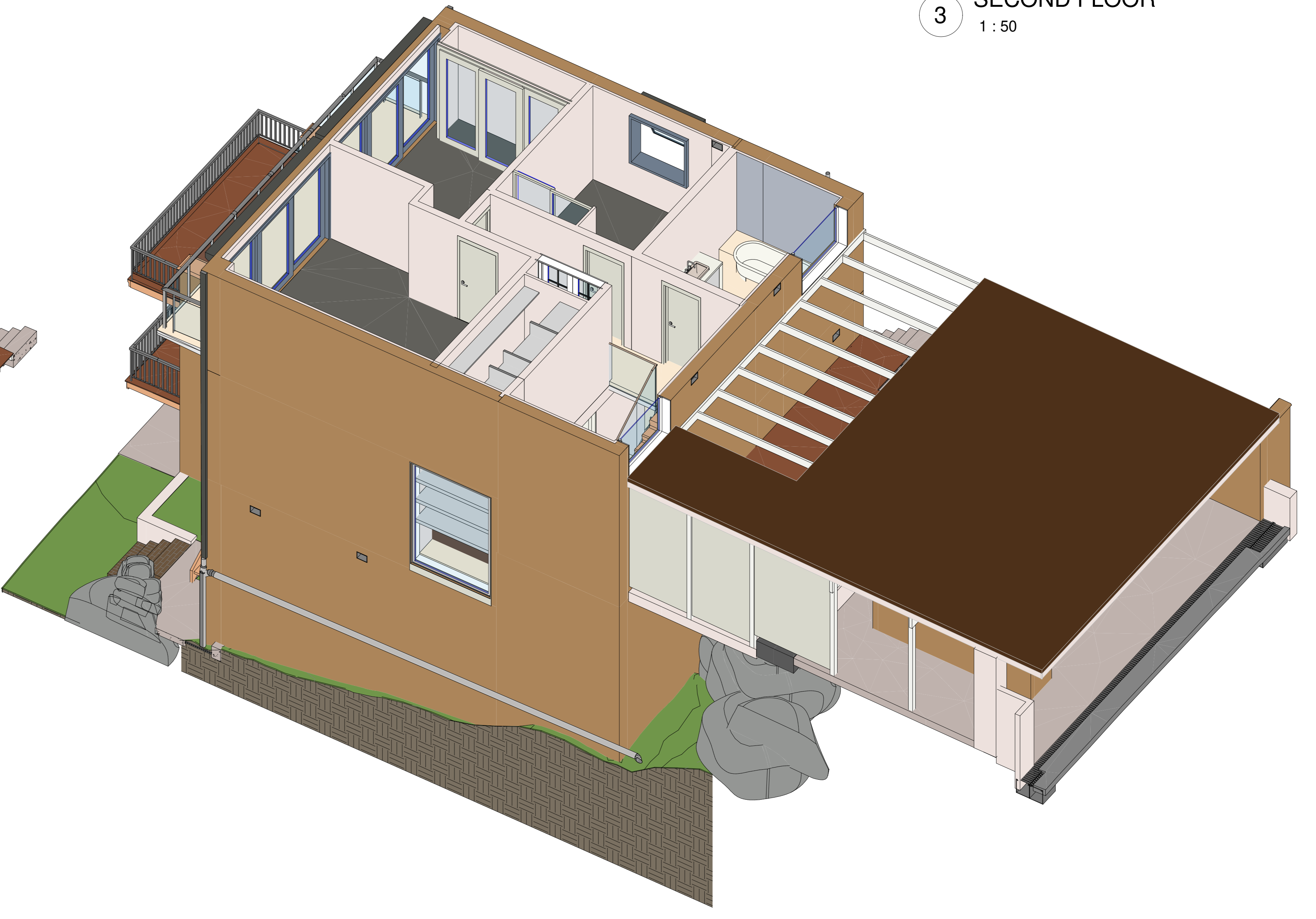

6 SECOND FLOOR 3D VIEW

ROOM SCHEDULE		
LEVEL	NAME	AREA
GROUND FLOOR	BATHROOM 1	6.87 m ²
GROUND FLOOR	CASUAL LIVING	34.29 m ²
GROUND FLOOR	STAIR AREA 1	6.97 m ²
FIRST FLOOR	DINING	9.91 m ²
FIRST FLOOR	HALLWAY 1	1.59 m ²
FIRST FLOOR	KITCHEN	12.03 m ²
FIRST FLOOR	LOUNGE	25.59 m ²
FIRST FLOOR	STAIR AREA 2	10.27 m ²
FIRST FLOOR	WALK IN PANTRY	4.47 m ²
SECOND FLOOR	BATHROOM	7.36 m ²
SECOND FLOOR	BEDROOM 1	8.89 m ²
SECOND FLOOR	BEDROOM 2	10.58 m ²
SECOND FLOOR	BEDROOM 3	17.24 m ²
SECOND FLOOR	HALLWAY 2	2.76 m ²
SECOND FLOOR	STAIR AREA 3	9.94 m ²
SECOND FLOOR	WALK IN ROBE	3.96 m ²

LEGEND:			
AHD	AUSTRALIAN HEIGHT DATUM	PAV	PAVERS
AWN	AWNING	PP	POWER POLE
BM	BENCH MARK	RL	REDUCED LEVEL
CONC	CONCRETE	RR	ROOF RIDGE
CS	CONCRETE SURFACE	SC	SERVICE COVER
DHS	DIAMETER/HEIGHT/SPREAD	SV	STOP VALVE
D	DOOR	TEL	TELSTRA PIT
E	EDGE OF CONCRETE	TK	TOP OF KERB
EG	EAVE & GUTTER	TW	TOP OF WALL
FL	FLOOR LEVEL	V	SERVICE VALVE
CDN	GARDEN	VC	VEHICLE CROSSING
HVD	HYDRANT	WM	WATER METER
IL	INVERT LEVEL	WS	WINDOW SILL
LH	LAMP POLE	WT	TOP OF WINDOW
NS	NATURAL SURFACE		

NOTE: THIS SURVEY WAS COMPLETED USING LASER SCANNING TECHNOLOGY AND CONVENTIONAL SURVEY EQUIPMENT. THE DATA WAS ACCURATE AT TIME OF SURVEY.

THIS PLAN AND THE INFORMATION CONTAINED HEREIN REMAINS THE PROPERTY OF C & A SURVEYORS NSW PTY LTD. IT MUST NOT BE COPIED IN WHOLE OR PART, AND IS NOT TO BE USED FOR ANY PURPOSE OTHER THAN FOR THAT WHICH IT HAS BEEN PREPARED. WITHOUT WRITTEN CONSENT OF C & A SURVEYORS NSW PTY LTD. THIS PLAN HAS BEEN PREPARED FOR THE SOLE USE OF THE INSTRUCTING PARTY.

C & A SURVEYORS NSW P/L
Ph: 9630 9299
30 GROSE STREET,
PARRAMATTA NSW 2151
info@candasurveyors.com.au
www.candasurveyors.com.au

DETAIL & IDENTIFICATION SURVEY, FLOOR PLANS, ELEVATIONS & 3D MODEL OF LOT 15 SEC K ON DP2610 AT 5 BARRABOOK STREET CLONTAF

INSTRUCTING PARTY: SQUILLACE ARCHITECTURE - RYAN		
Revision No.	Description	Date
01	DETAIL/IDENT SURVEY, FLOOR PLANS, ELEVATIONS & 3D MODEL	13/11/2023
02		
03		
04		

NOTES ON SURVEY
1. THE IDENTIFICATION COMPONENT OF THIS SURVEY SHOWING DISTANCES BETWEEN STRUCTURES AS SURVEYED AND CADASTRAL BOUNDARIES HAS BEEN CONDUCTED IN ACCORDANCE WITH CLAUSE 10 OF THE SURVEYING AND SPATIAL INFORMATION REGULATION 2017.
2. THE 2D & 3D DETAIL AND MODELLING COMPONENT OF THIS SURVEY HAS BEEN CONDUCTED IN ACCORDANCE WITH CLAUSE 9 OF THE SURVEYING AND SPATIAL INFORMATION REGULATION 2017.

SECOND SCHEDULE (2 NOTIFICATIONS) AS SEARCHED ON 01/11/2023
1. RESERVATIONS AND CONDITIONS IN THE CROWN GRANT(S)
2. AP494651 MORTGAGE TO MACQUARIE BANK LIMITED

NOTES:
A) SERVICES SHOWN HAVE BEEN DERIVED FROM VISUAL EVIDENCE APPARENT AT THE TIME OF SURVEY. SERVICES MAY EXIST WHICH ARE NOT SHOWN. THE RELEVANT SERVICE AUTHORITY SHOULD BE CONTACTED TO VERIFY THE EXISTENCE AND POSITION OF SERVICES PRIOR TO THE COMMENCEMENT OF ANY CONSTRUCTION OR EXCAVATION.
B) DIAMETER, HEIGHT & SPREAD OF TREES ARE APPROXIMATE ONLY.
C) LEVELS SHOWN ARE OF AUSTRALIAN HEIGHT DATUM.
D) ORIGIN OF LEVELS: PMS3493 RL 40.955 (AHD), CLASS LB
E) USE STATED DIMENSIONS. DO NOT SCALE.
F) THESE NOTES FORM PART OF THIS PLAN AND CANNOT BE REMOVED.
G) NO COVENANTS AND/OR RESTRICTIONS HAVE BEEN INVESTIGATED BY C & A SURVEYORS PTY LTD.

DATUM:	AHD	SURVEYED BY:	JG/TS
SURVEY DATE:	02/11/2023	DRAWN BY:	MZ/AH
DATE DRAWN:	03/11/2023	SCALE:	1 : 50@A0
REFERENCE:	30921-23	SHEET:	3 OF 7

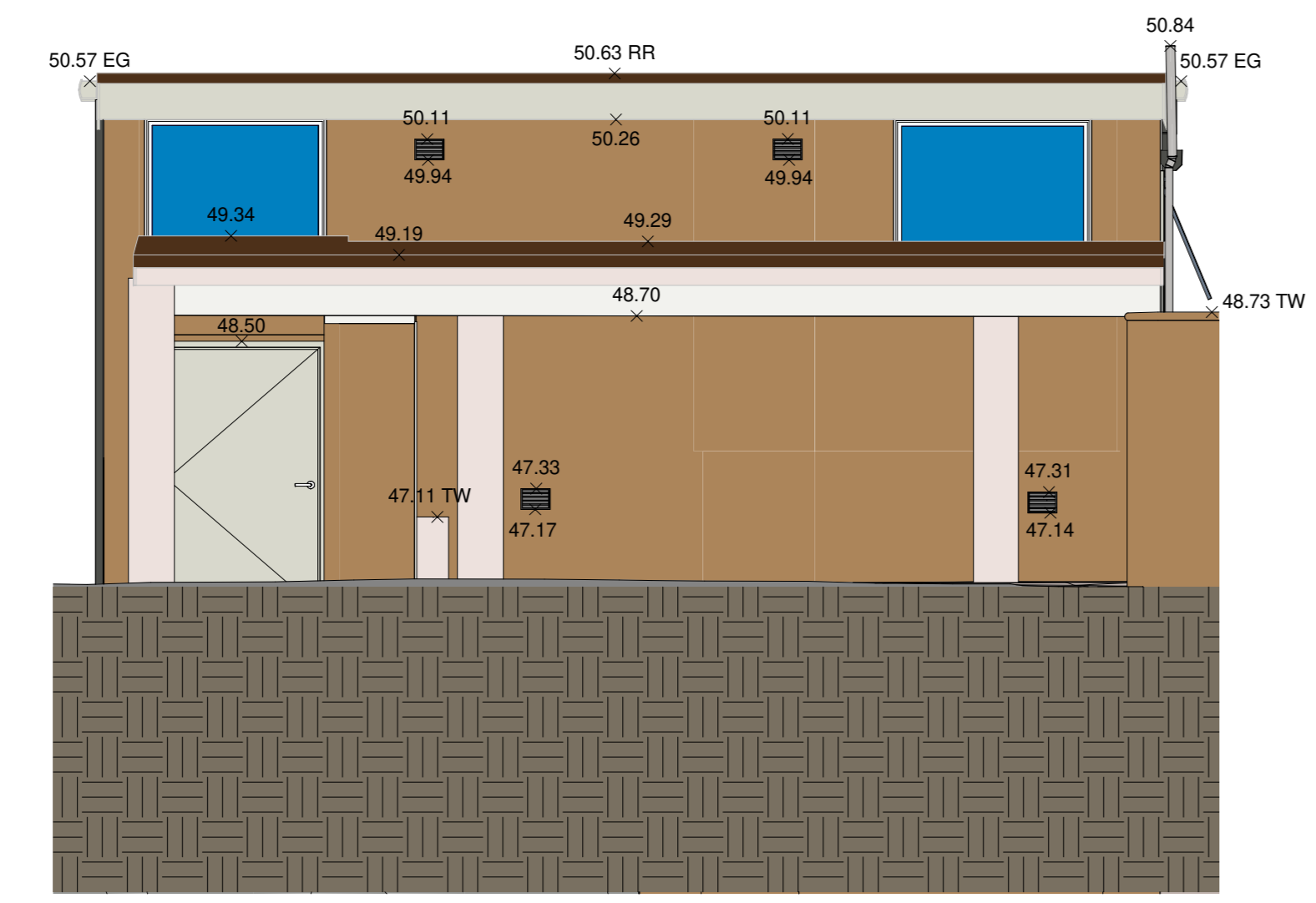

1 5 BARRABOOKA STREET CLONTARF FRONT ELEVATION
1 : 50

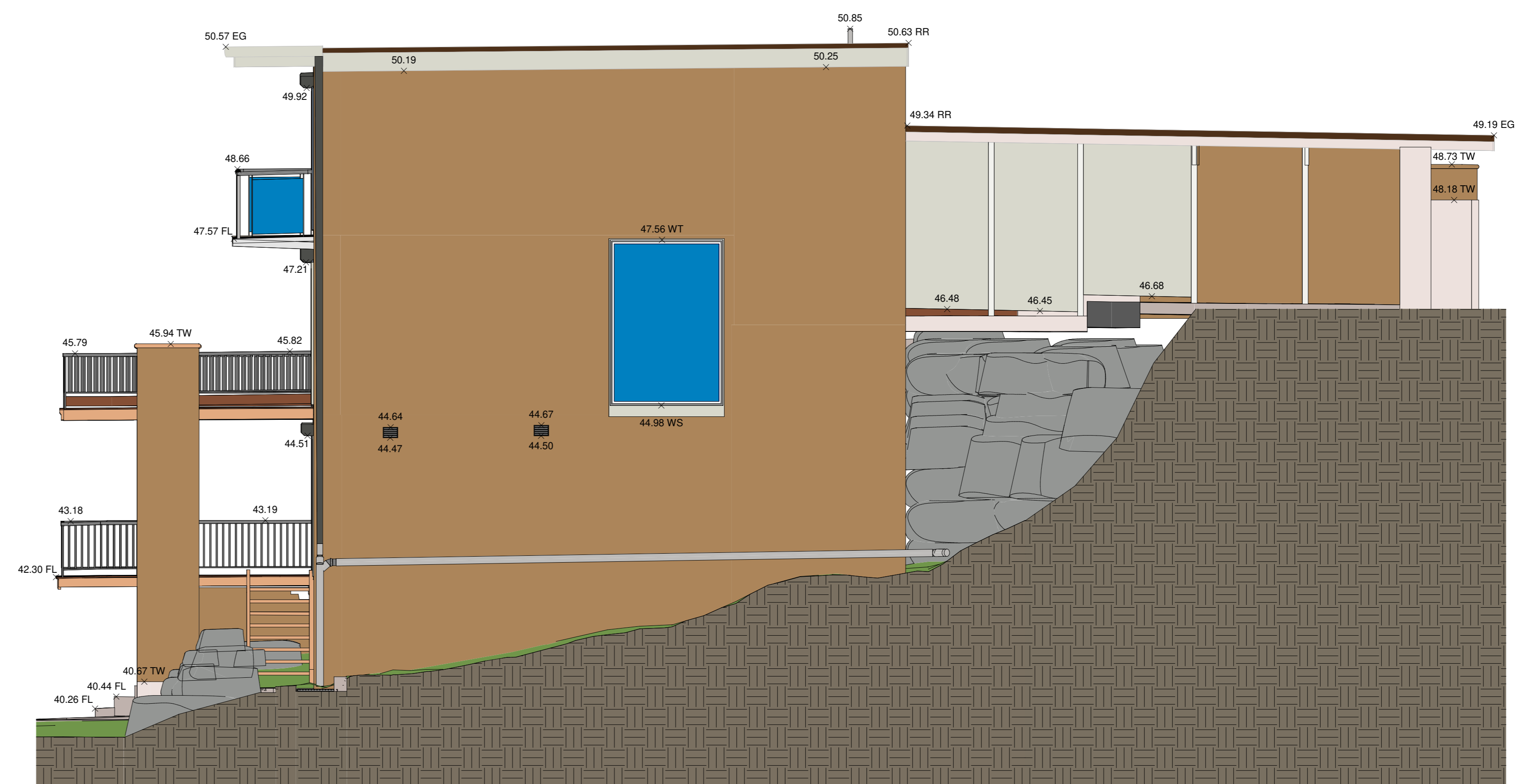

2 5 BARRABOOKA STREET CLONTARF LEFT ELEVATION
1 : 50

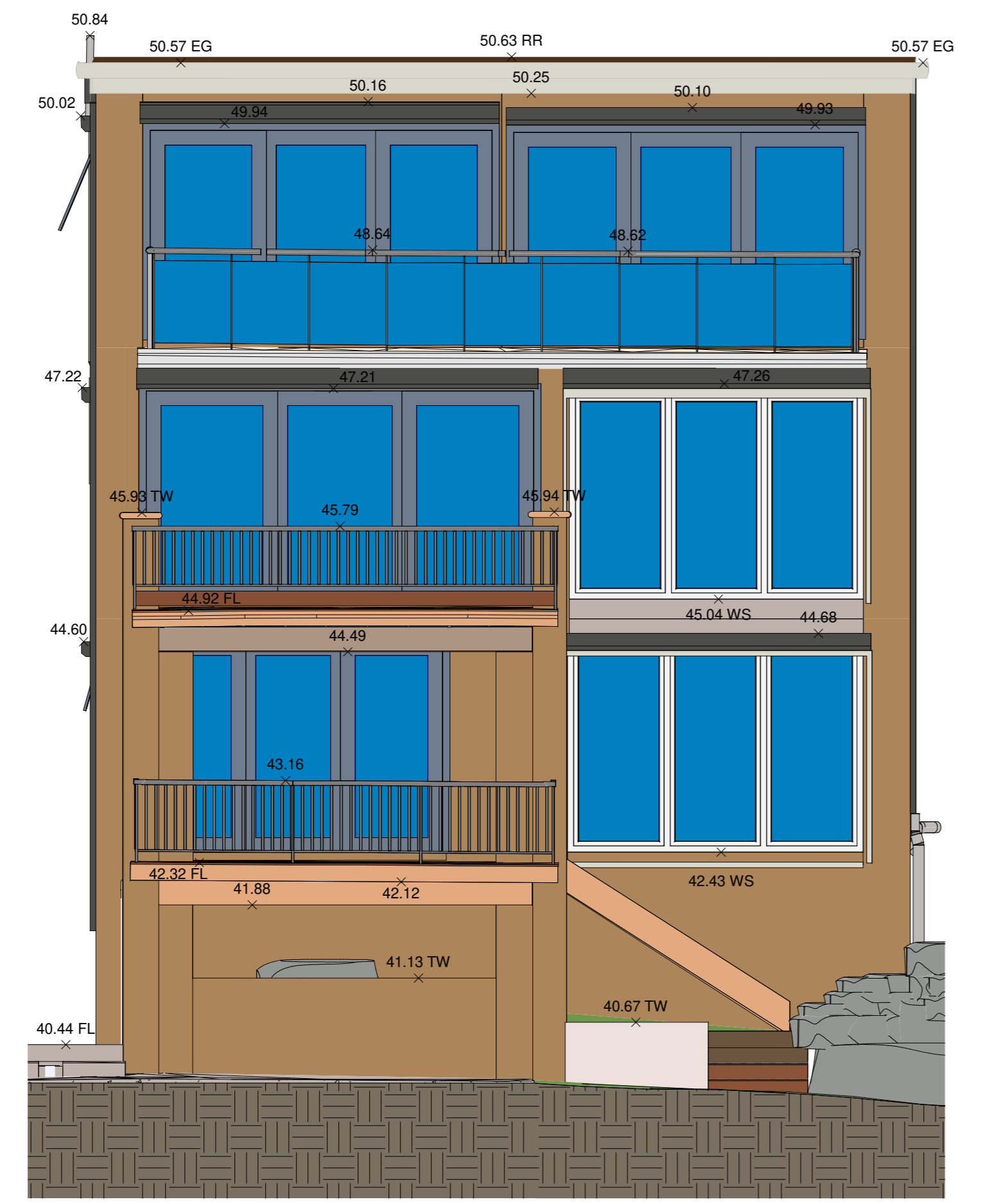

3 5 BARRABOOKA STREET CLONTARF REAR ELEVATION
1 : 50

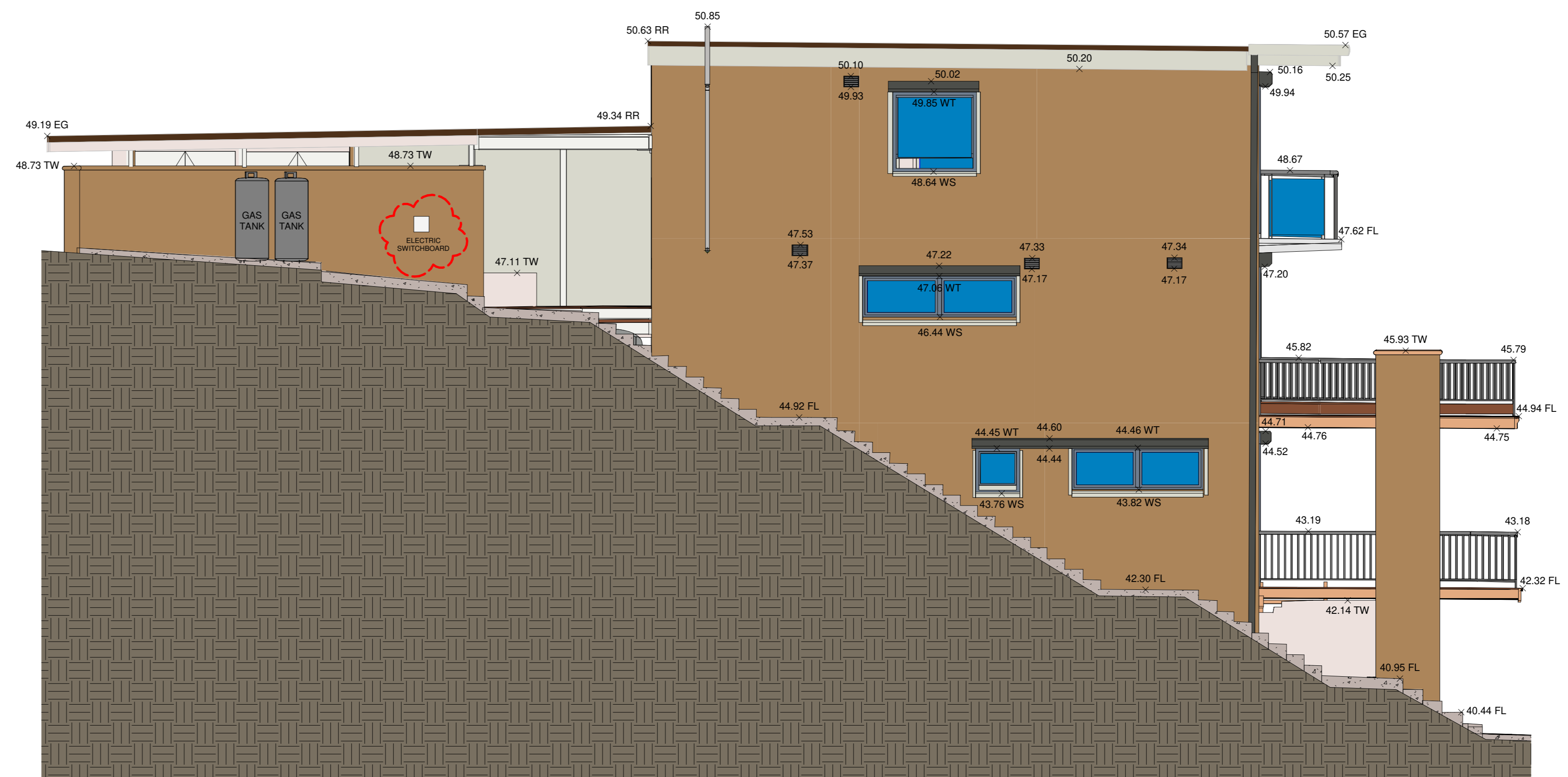

4 5 BARRABOOKA STREET CLONTARF RIGHT ELEVATION
1 : 50

LEGEND:

AHD	AUSTRALIAN HEIGHT DATUM	PAV	PAVERS
AWN	AWNING	PP	POWER POLE
BM	BENCH MARK	RL	REDUCED LEVEL
CONC	CONCRETE	RR	ROOF RIDGE
CS	CONCRETE SURFACE	SC	SERVICE COVER
DIHS	DIAMETER/HEIGHT/SPREAD	SV	STOP VALVE
D	DOOR	TEL	TELSTRA PIT
E	EDGE OF CONCRETE	TK	TOP OF KERB
EG	EAVE & GUTTER	TW	TOP OF WALL
FL	FLOOR LEVEL	V	SERVICE VALVE
CDN	GARDEN	VC	VEHICLE CROSSING
HYD	HYDRANT	WM	WATER METER
IL	INVERT LEVEL	WS	WINDOW SILL
LH	LAMP POLE	WT	TOP OF WINDOW
NS	NATURAL SURFACE		

NOTE: THIS SURVEY WAS COMPLETED USING LASER SCANNING TECHNOLOGY AND CONVENTIONAL SURVEY EQUIPMENT. THE DATA WAS ACCURATE AT TIME OF SURVEY.

SECOND SCHEDULE (2 NOTIFICATIONS) AS SEARCHED ON 01/11/2023
1. RESERVATIONS AND CONDITIONS IN THE CROWN GRANT(S)
2. AP494651 MORTGAGE TO MACQUARIE BANK LIMITED

NOTES:
A) SERVICES SHOWN HAVE BEEN DERIVED FROM VISUAL EVIDENCE APPARENT AT THE TIME OF SURVEY. SERVICES MAY EXIST WHICH ARE NOT SHOWN. THE RELEVANT SERVICE AUTHORITY SHOULD BE CONTACTED TO VERIFY THE EXISTENCE AND POSITION OF SERVICES PRIOR TO THE COMMENCEMENT OF ANY CONSTRUCTION OR EXCAVATION.
B) DIAMETER, HEIGHT & SPREAD OF TREES ARE APPROXIMATE ONLY.
C) LEVELS SHOWN ARE OF AUSTRALIAN HEIGHT DATUM.
D) ORIGIN OF LEVELS: PMS3493 RL 49.925 (AHD) CLASS LB
E) USE STATED DIMENSIONS. DO NOT SCALE.
F) THESE NOTES FORM PART OF THIS PLAN AND CANNOT BE REMOVED.
G) NO COVENANTS AND/OR RESTRICTIONS HAVE BEEN INVESTIGATED BY C & A SURVEYORS PTY LTD.

THIS PLAN AND THE INFORMATION CONTAINED HEREIN REMAINS THE PROPERTY OF C & A SURVEYORS NSW PTY LTD. IT MUST NOT BE COPIED IN WHOLE OR PART, AND IS NOT TO BE USED FOR ANY PURPOSE OTHER THAN FOR THAT WHICH IT HAS BEEN PREPARED. WITHOUT WRITTEN CONSENT OF C & A SURVEYORS NSW PTY LTD. THIS PLAN HAS BEEN PREPARED FOR THE SOLE USE OF THE INSTRUCTING PARTY.

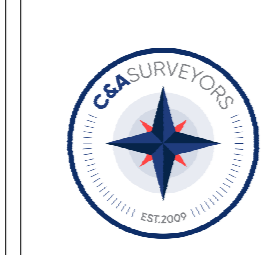

C & A SURVEYORS NSW P/L
Ph: 9630 9299
30 GROSE STREET,
PARRAMATTA NSW 2151
info@candasurveyors.com.au
www.candasurveyors.com.au

DETAIL & IDENTIFICATION SURVEY, FLOOR PLANS, ELEVATIONS & 3D MODEL OF LOT 15 SEC K ON DP2610 AT 5 BARRABOOK STREET CLONTAF

INSTRUCTING PARTY: SQUILLACE ARCHITECTURE - RYAN

Revision No.	Description	Date
01	DETAIL/IDENT SURVEY, FLOOR PLANS, ELEVATIONS & 3D MODEL	13/11/2023
02		
03		
04		

NOTES ON SURVEY
1. THE IDENTIFICATION COMPONENT OF THIS SURVEY SHOWING DISTANCES BETWEEN STRUCTURES AS SURVEYED AND CADASTRAL BOUNDARIES HAS BEEN CONDUCTED IN ACCORDANCE WITH CLAUSE 10 OF THE SURVEYING AND SPATIAL INFORMATION REGULATION 2017.
2. THE 2D & 3D DETAIL AND MODELLING COMPONENT OF THIS SURVEY HAS BEEN CONDUCTED IN ACCORDANCE WITH CLAUSE 9 OF THE SURVEYING AND SPATIAL INFORMATION REGULATION 2017.

DATUM:	AHD	SURVEYED BY:	B/JG/TS
SURVEY DATE:	02/11/2023	DRAWN BY:	MZ/AH
DATE DRAWN:	03/11/2023	SCALE:	1 : 50@A0
REFERENCE:	30921-23	SHEET:	4 OF 7

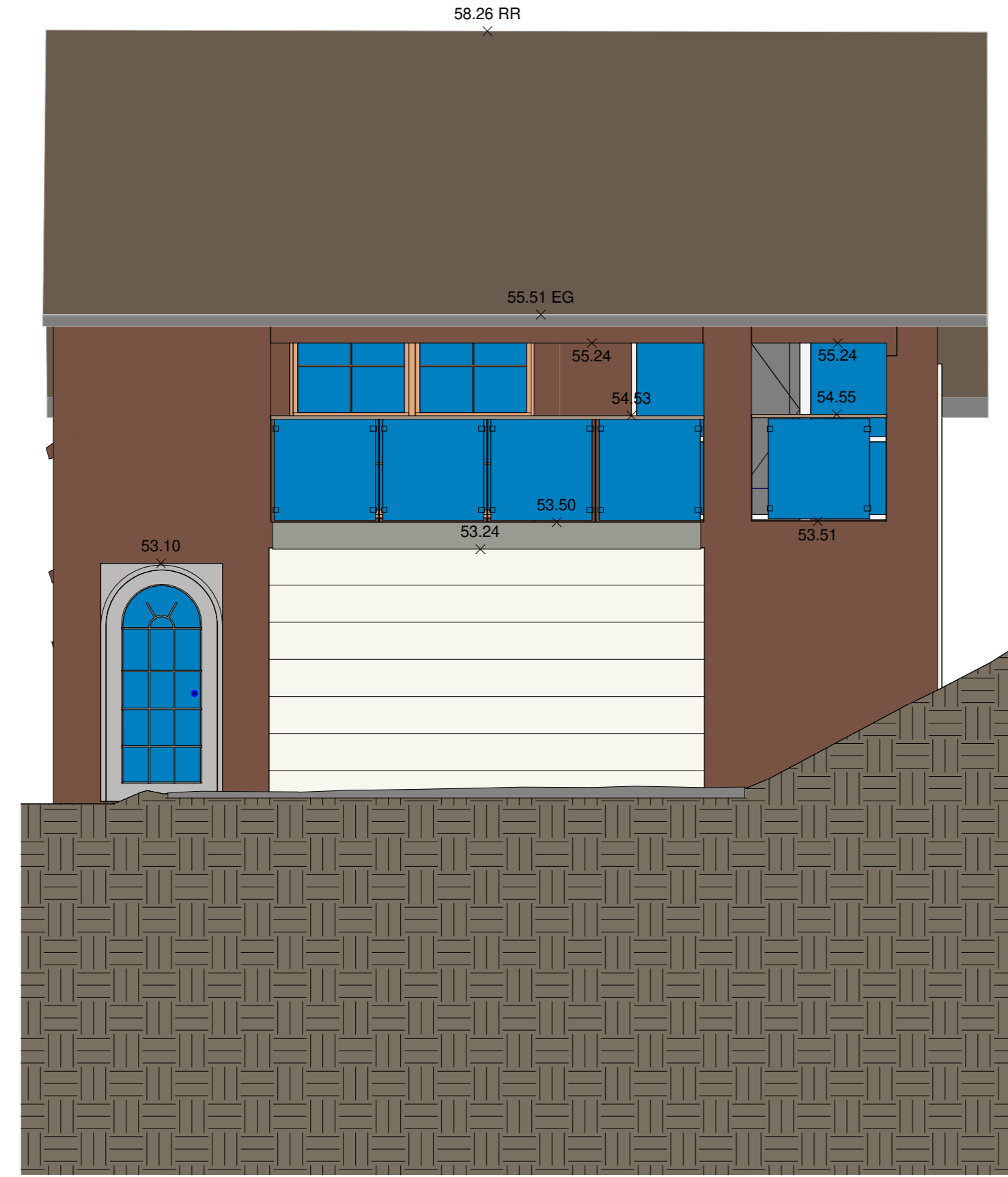

1 7 BARRABOOKA STREET CLONTARF FRONT ELEVATION
1 : 50

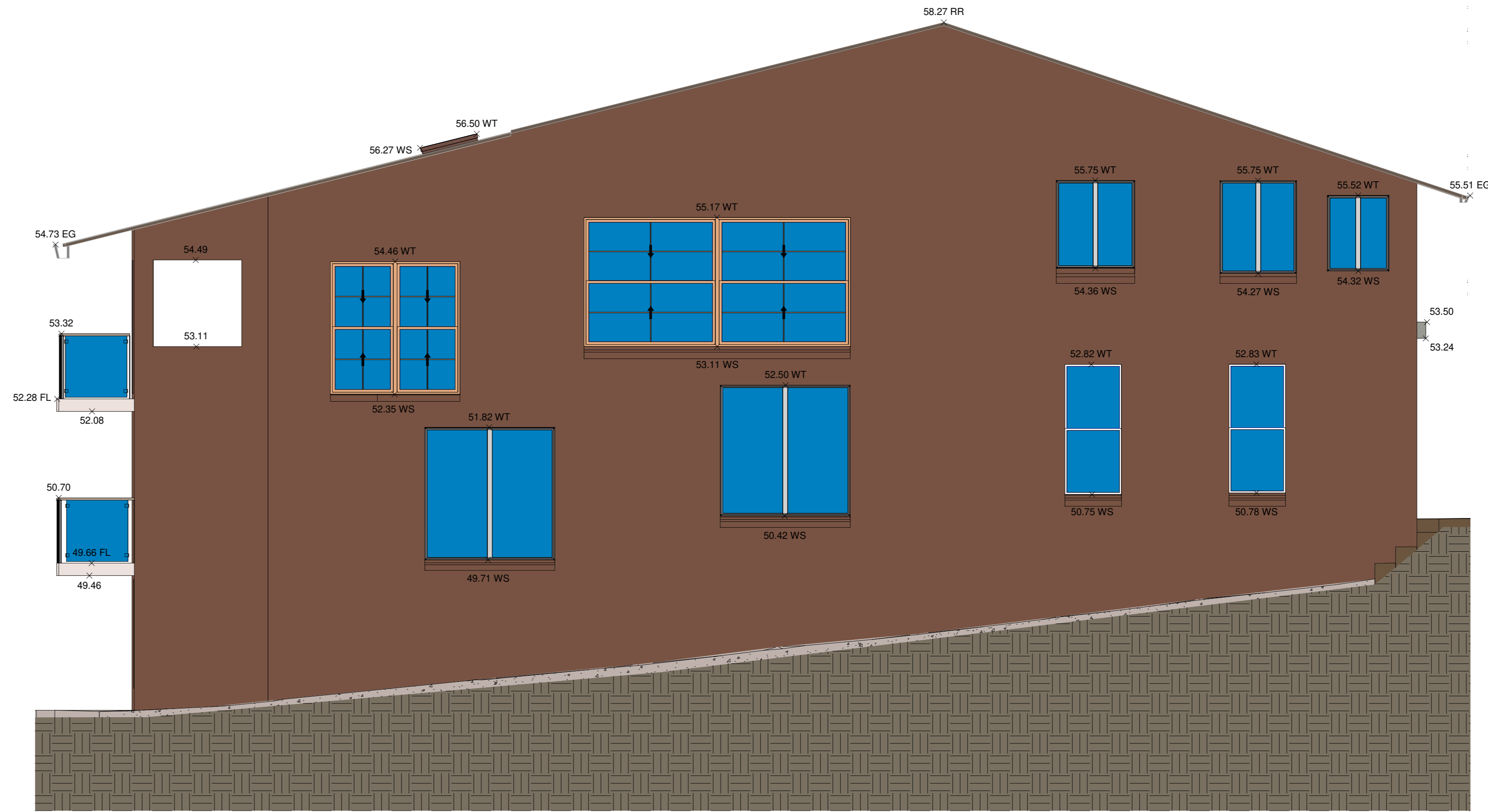

2 7 BARRABOOKA STREET CLONTARF LEFT ELEVATION
1 : 50

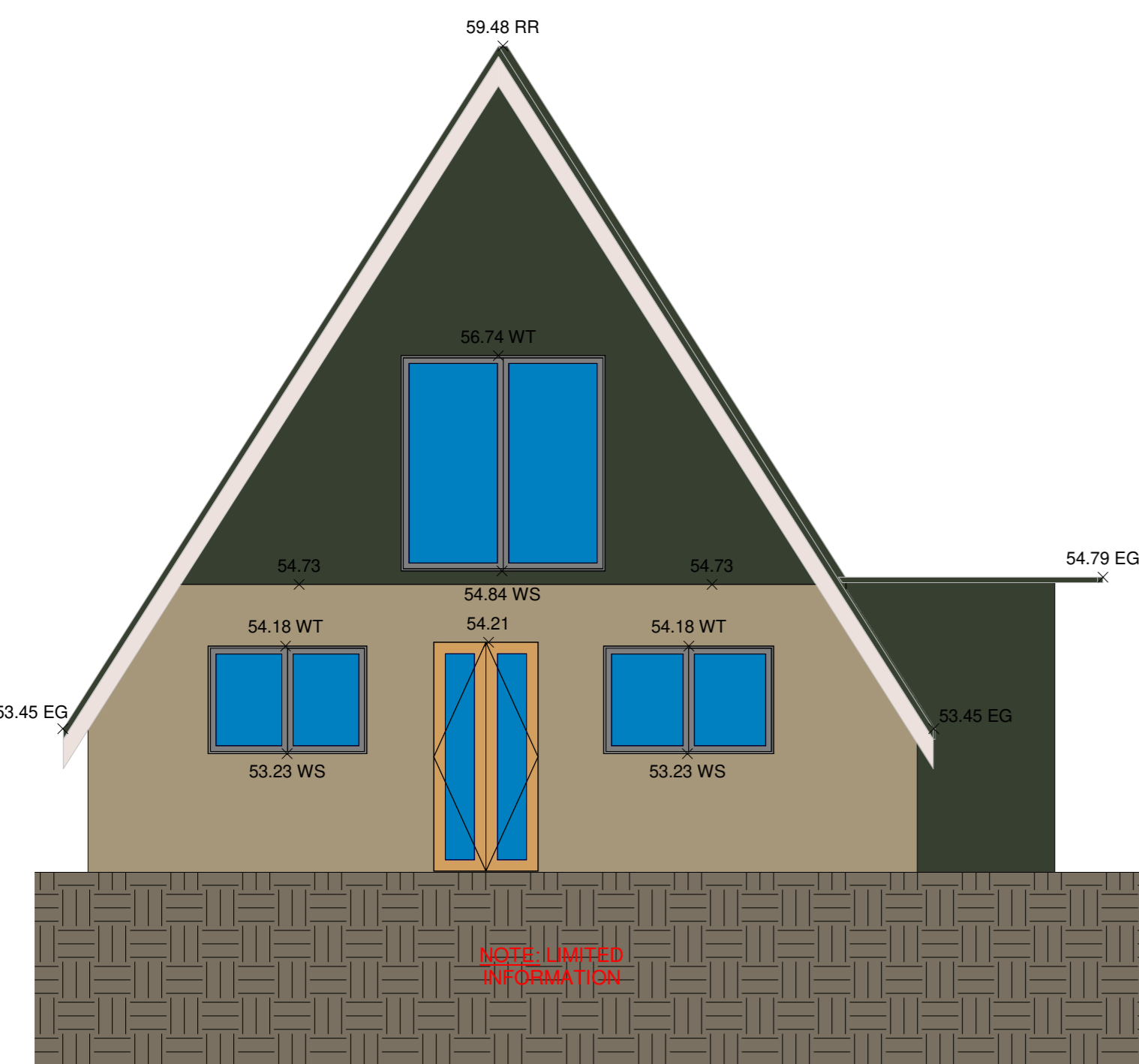

3 11 BARRABOOKA STREET CLONTARF FRONT ELEVATION
1 : 50

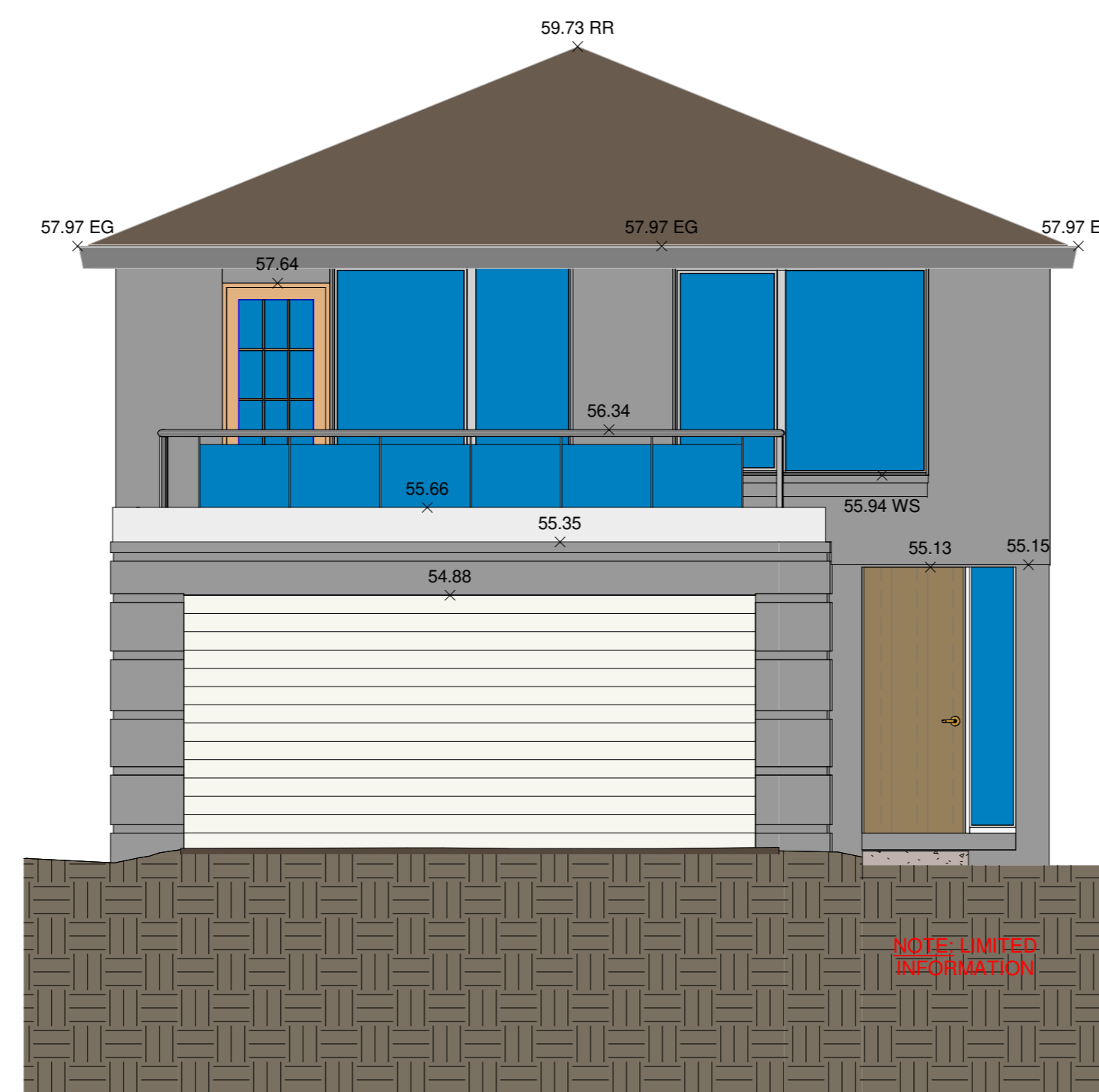

4 13 BARRABOOKA STREET CLONTARF FRONT ELEVATION
1 : 50



5 13 BARRABOOKA STREET CLONTARF LEFT ELEVATION
1 : 50

LEGEND:

AHD	AUSTRALIAN HEIGHT DATUM	PAV	PAVERS
AWN	AWNING	PP	POWER POLE
BM	BENCH MARK	RL	REDUCED LEVEL
CONC	CONCRETE	RR	ROOF RIDGE
CS	CONCRETE SURFACE	SC	SERVICE COVER
DI/HS	DIAMETER/HEIGHT/SPREAD	SV	STOP VALVE
D	DOOR	TEL	TELSTRA PIT
EC	EDGE OF CONCRETE	TK	TOP OF KERB
EG	EAVE & GUTTER	TW	TOP OF WALL
FL	FLOOR LEVEL	V	VEHICLE CROSSING
CDN	GARDEN	VC	VEHICLE CROSSING
HVD	HYDRANT	WM	WATER METER
IL	INVERT LEVEL	WS	WINDOW SILL
LH	LAMP POLE	WT	TOP OF WINDOW
NS	NATURAL SURFACE		

NOTE: THIS SURVEY WAS COMPLETED USING LASER SCANNING TECHNOLOGY AND CONVENTIONAL SURVEY EQUIPMENT. THE DATA WAS ACCURATE AT TIME OF SURVEY.

THIS PLAN AND THE INFORMATION CONTAINED HEREIN REMAINS THE PROPERTY OF C & A SURVEYORS NSW PTY LTD. IT MUST NOT BE COPIED IN WHOLE OR PART, AND IS NOT TO BE USED FOR ANY PURPOSE OTHER THAN FOR THAT WHICH IT HAS BEEN PREPARED. WITHOUT WRITTEN CONSENT OF C & A SURVEYORS NSW PTY LTD. THIS PLAN HAS BEEN PREPARED FOR THE SOLE USE OF THE INSTRUCTING PARTY.



C & A SURVEYORS NSW P/L
Ph: 9630 9299
30 GROSE STREET,
PARRAMATTA NSW 2151
info@candasurveyors.com.au
www.candasurveyors.com.au

DETAIL & IDENTIFICATION SURVEY, FLOOR PLANS, ELEVATIONS & 3D MODEL OF LOT 15 SEC K ON DP2610 AT 5 BARRABOOK STREET CLONTAF

INSTRUCTING PARTY: SQUILLACE ARCHITECTURE - RYAN

Revision No.	Description	Date
01	DETAIL/IDENT SURVEY, FLOOR PLANS, ELEVATIONS & 3D MODEL	13/11/2023
02		
03		
04		

NOTES ON SURVEY

- THE IDENTIFICATION COMPONENT OF THIS SURVEY SHOWING DISTANCES BETWEEN STRUCTURES AS SURVEYED AND CADASTRAL BOUNDARIES HAS BEEN CONDUCTED IN ACCORDANCE WITH CLAUSE 10 OF THE SURVEYING AND SPATIAL INFORMATION REGULATION 2017.
- THE 2D & 3D DETAIL AND MODELLING COMPONENT OF THIS SURVEY HAS BEEN CONDUCTED IN ACCORDANCE WITH CLAUSE 9 OF THE SURVEYING AND SPATIAL INFORMATION REGULATION 2017.

SECOND SCHEDULE (2 NOTIFICATIONS) AS SEARCHED ON 01/11/2023

- RESERVATIONS AND CONDITIONS IN THE CROWN GRANT(S)
- AP494651 MORTGAGE TO MACQUARIE BANK LIMITED

NOTES:

- SERVICES SHOWN HAVE BEEN DERIVED FROM VISUAL EVIDENCE APPARENT AT THE TIME OF SURVEY. SERVICES MAY EXIST WHICH ARE NOT SHOWN. THE RELEVANT SERVICE AUTHORITY SHOULD BE CONTACTED TO VERIFY THE EXISTENCE AND POSITION OF SERVICES PRIOR TO THE COMMENCEMENT OF ANY CONSTRUCTION OR EXCAVATION.
- DIAMETER, HEIGHT & SPREAD OF TREES ARE APPROXIMATE ONLY.
- LEVELS SHOWN ARE OF AUSTRALIAN HEIGHT DATUM.
- ORIGIN OF LEVELS: PMD3493 RL 49.925 (AHD), CLASS LB
- USE STATED DIMENSIONS. DO NOT SCALE.
- THESE NOTES FORM PART OF THIS PLAN AND CANNOT BE REMOVED.
- NO COVENANTS AND/OR RESTRICTIONS HAVE BEEN INVESTIGATED BY C & A SURVEYORS PTY LTD.

DATUM:	AHD	SURVEYED BY:	B/JG/T/S
SURVEY DATE:	02/11/2023	DRAWN BY:	MZ/AH
DATE DRAWN:	03/11/2023	SCALE:	1 : 50@A0
REFERENCE:	30921-23	SHEET:	5 OF 7

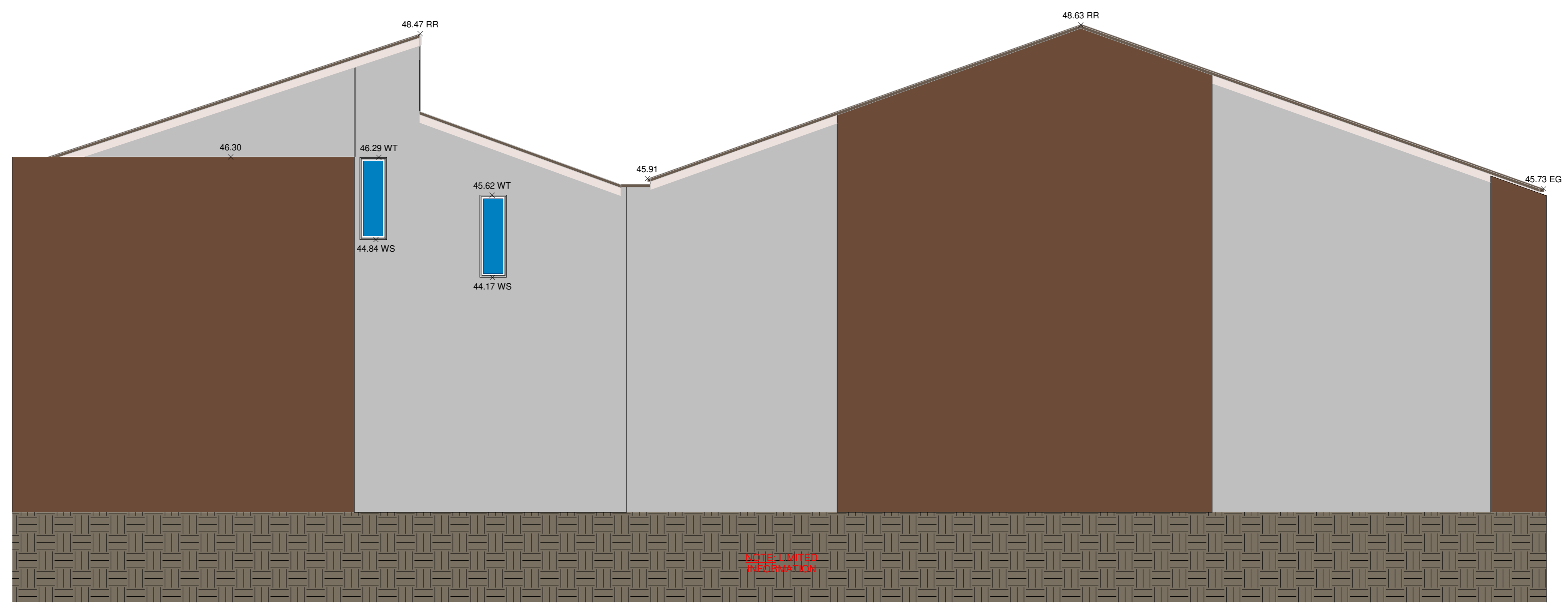
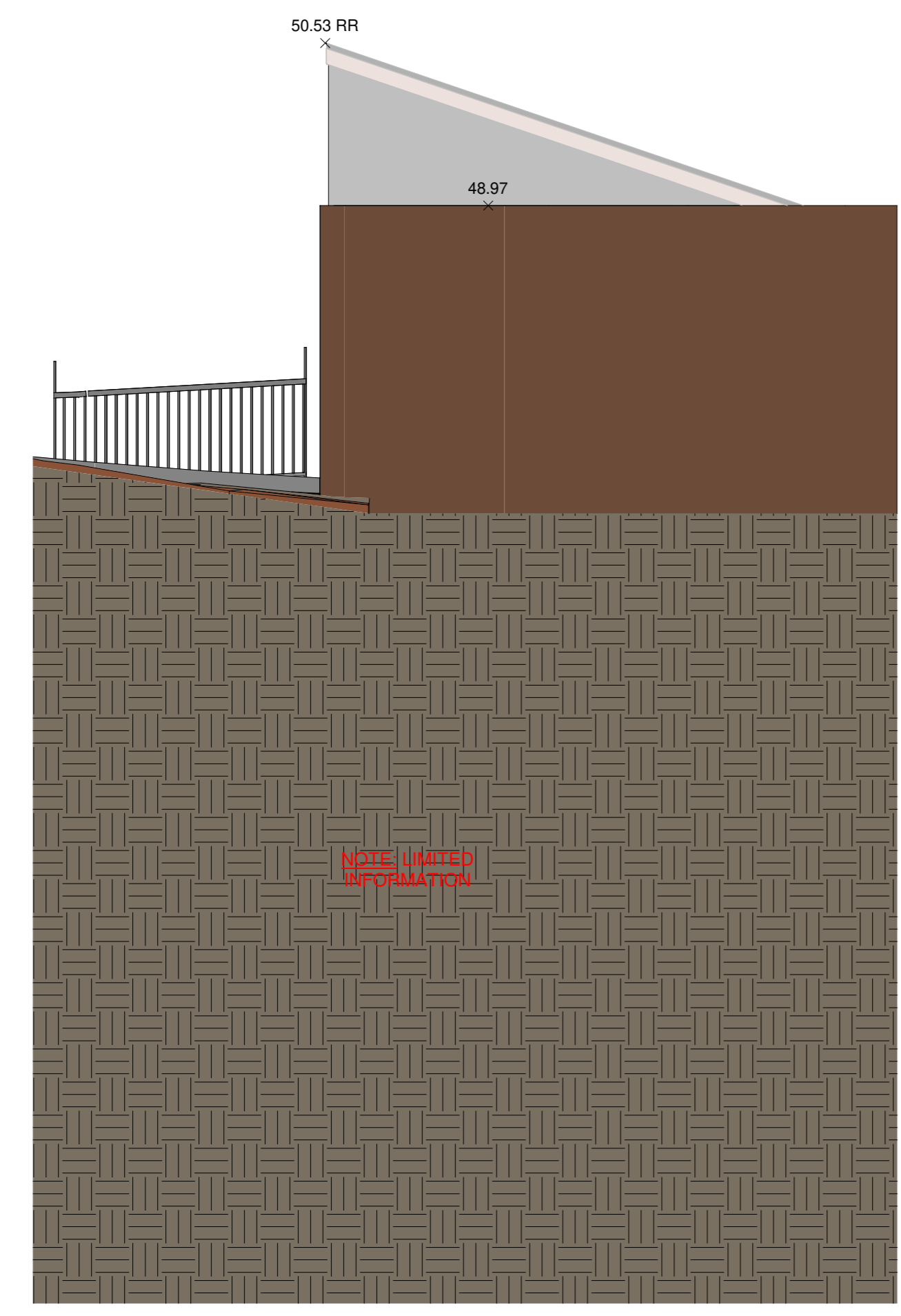

1 BARRABOOKA STREET CLONTARF RIGHT ELEVATION
1 : 50

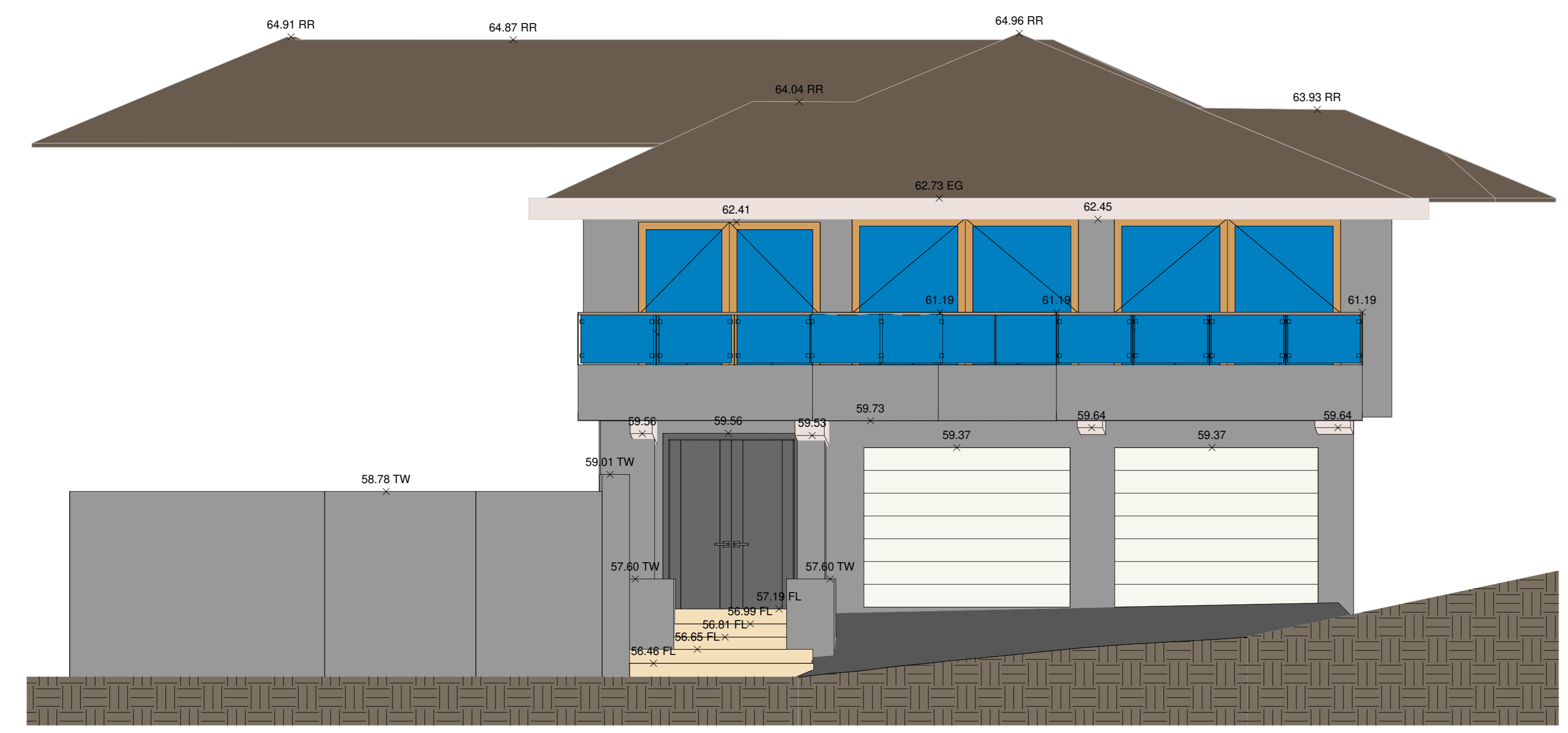

2 BARRABOOKA STREET CLONTARF FRONT ELEVATION
1 : 50

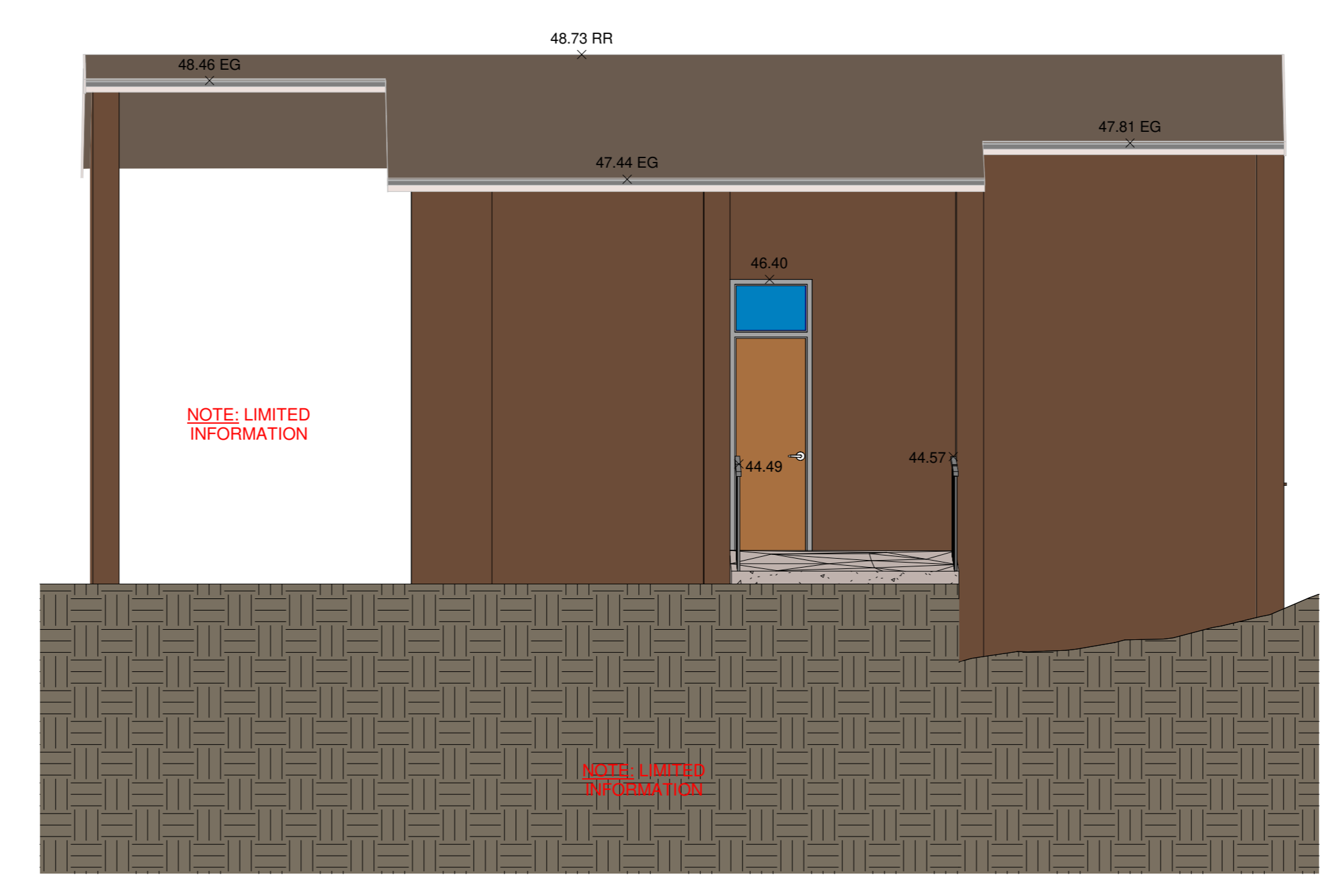

3 BARRABOOKA STREET CLONTARF FRONT ELEVATION
1 : 50



4 3 BARRABOOKA STREET CLONTARF REAR ELEVATION
1 : 50

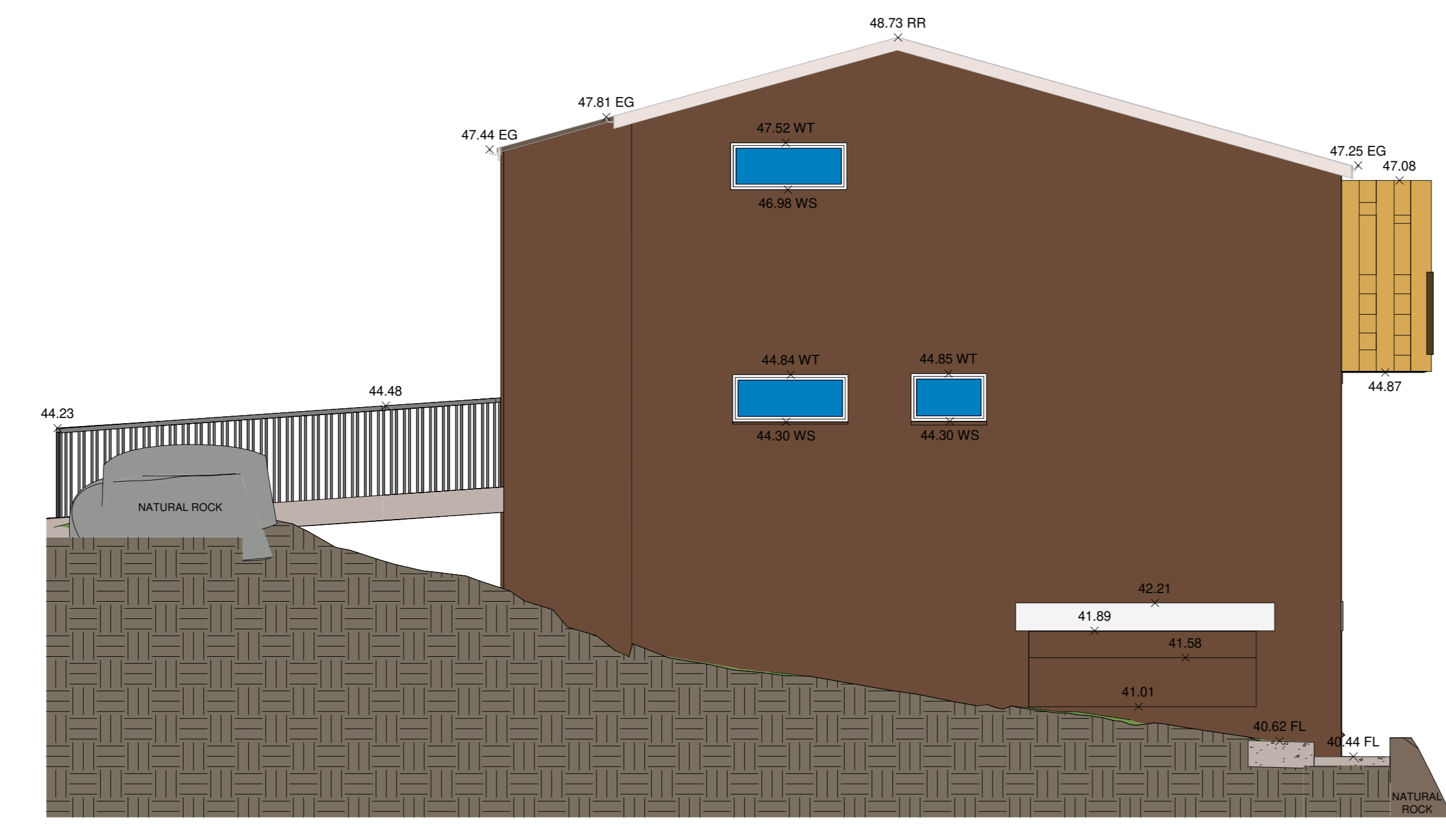

5 3 BARRABOOKA STREET CLONTARF RIGHT ELEVATION
1 : 50

LEGEND:

AHD	AUSTRALIAN HEIGHT DATUM	PAV	PAVERS
AWN	AWNING	PP	POWER POLE
BM	BENCH MARK	RL	REDUCED LEVEL
CONC	CONCRETE	RR	ROOF RIDGE
CS	CONCRETE SURFACE	SC	SERVICE COVER
DIHS	DIAMETER/HEIGHT/SPREAD	SV	STOP VALVE
D	DOOR	TEL	TELSTRA PIT
EC	EDGE OF CONCRETE	TK	TOP OF KERB
EG	EAVE & GUTTER	TW	TOP OF WALL
FL	FLOOR LEVEL	V	SERVICE VALVE
CDN	GARDEN	VC	VEHICLE CROSSING
HYD	HYDRANT	WM	WATER METER
IL	INVERT LEVEL	WS	WINDOW SILL
LH	LAMP POLE	WT	TOP OF WINDOW
NS	NATURAL SURFACE		

NOTE: THIS SURVEY WAS COMPLETED USING LASER SCANNING TECHNOLOGY AND CONVENTIONAL SURVEY EQUIPMENT. THE DATA WAS ACCURATE AT TIME OF SURVEY.

THIS PLAN AND THE INFORMATION CONTAINED HEREIN REMAINS THE PROPERTY OF C & A SURVEYORS NSW PTY LTD. IT MUST NOT BE COPIED IN WHOLE OR PART, AND IS NOT TO BE USED FOR ANY PURPOSE OTHER THAN FOR THAT WHICH IT HAS BEEN PREPARED. WITHOUT WRITTEN CONSENT OF C & A SURVEYORS NSW PTY LTD. THIS PLAN HAS BEEN PREPARED FOR THE SOLE USE OF THE INSTRUCTING PARTY.

C & A SURVEYORS NSW P/L
Ph: 9630 9299
30 GROSE STREET,
PARRAMATTA NSW 2151
info@candasurveyors.com.au
www.candasurveyors.com.au

DETAIL & IDENTIFICATION SURVEY, FLOOR PLANS, ELEVATIONS & 3D MODEL OF LOT 15 SEC K ON DP2610 AT 5 BARRABOOK STREET CLONTAF

INSTRUCTING PARTY: SQUILLACE ARCHITECTURE - RYAN

Revision No.	Description	Date
01	DETAIL/IDENT SURVEY, FLOOR PLANS, ELEVATIONS & 3D MODEL	13/11/2023
02		
03		
04		

NOTES ON SURVEY
1. THE IDENTIFICATION COMPONENT OF THIS SURVEY SHOWING DISTANCES BETWEEN STRUCTURES AS SURVEYED AND CADASTRAL BOUNDARIES HAS BEEN CONDUCTED IN ACCORDANCE WITH CLAUSE 10 OF THE SURVEYING AND SPATIAL INFORMATION REGULATION 2017.
2. THE 2D & 3D DETAIL AND MODELLING COMPONENT OF THIS SURVEY HAS BEEN CONDUCTED IN ACCORDANCE WITH CLAUSE 9 OF THE SURVEYING AND SPATIAL INFORMATION REGULATION 2017.

SECOND SCHEDULE (2 NOTIFICATIONS) AS SEARCHED ON 01/11/2023
1. RESERVATIONS AND CONDITIONS IN THE CROWN GRANT(S)
2. AP494651 MORTGAGE TO MACQUARIE BANK LIMITED

NOTES:
A) SERVICES SHOWN HAVE BEEN DERIVED FROM VISUAL EVIDENCE APPARENT AT THE TIME OF SURVEY. SERVICES MAY EXIST WHICH ARE NOT SHOWN. THE RELEVANT SERVICE AUTHORITY SHOULD BE CONTACTED TO VERIFY THE EXISTENCE AND POSITION OF SERVICES PRIOR TO THE COMMENCEMENT OF ANY CONSTRUCTION OR EXCAVATION.
B) DIAMETER, HEIGHT & SPREAD OF TREES ARE APPROXIMATE ONLY.
C) LEVELS SHOWN ARE OF AUSTRALIAN HEIGHT DATUM.
D) ORIGIN OF LEVELS: PMS3493 RL 49.955 (AHD), CLASS LB
E) USE STATED DIMENSIONS. DO NOT SCALE.
F) THESE NOTES FORM PART OF THIS PLAN AND CANNOT BE REMOVED.
G) NO COVENANTS AND/OR RESTRICTIONS HAVE BEEN INVESTIGATED BY C & A SURVEYORS PTY LTD.

DATUM:	AHD	SURVEYED BY: JG/TS
SURVEY DATE:	02/11/2023	DRAWN BY: MZ/AH
DATE DRAWN:	03/11/2023	SCALE: 1 : 50@A0
REFERENCE:	30921-23	SHEET: 6 OF 7

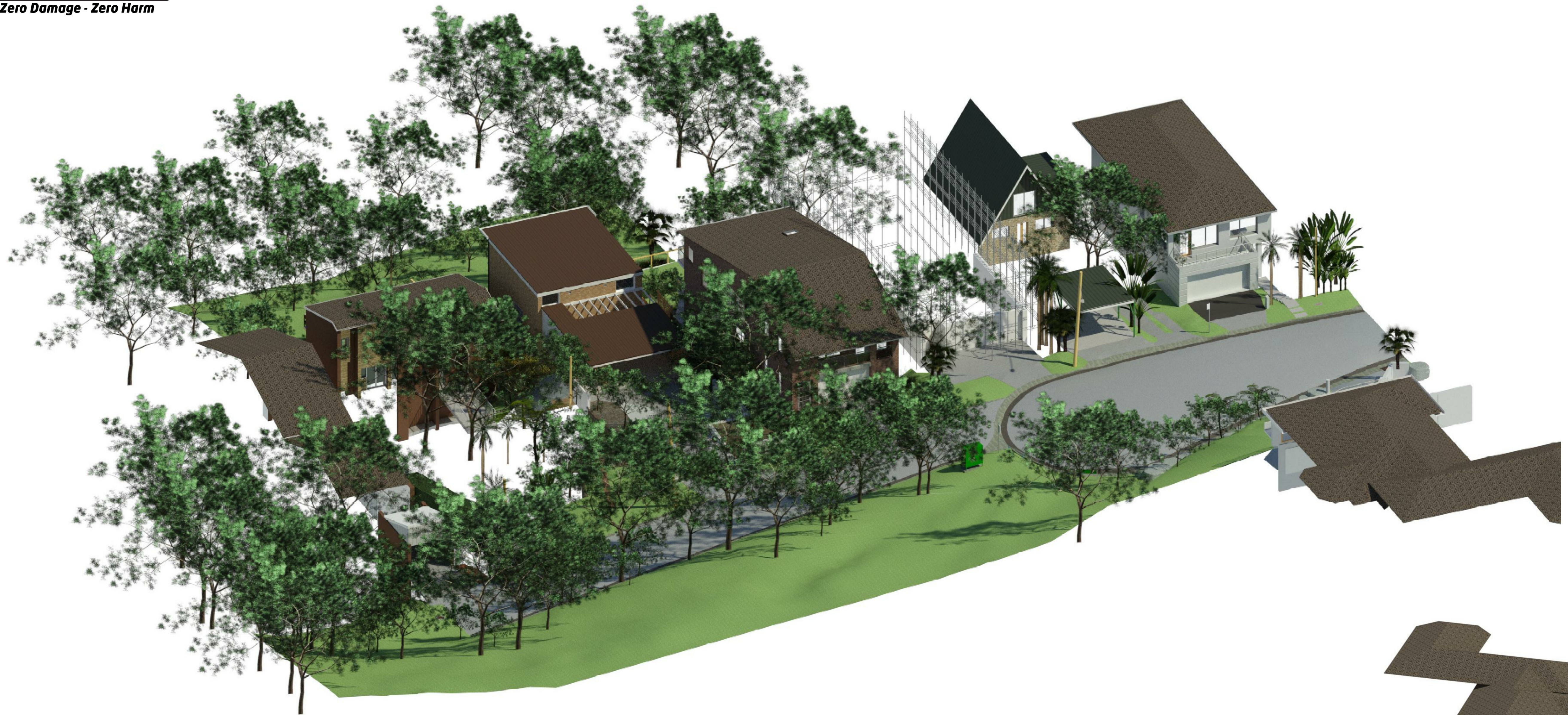

1 3D FRONT VIEW
1:1

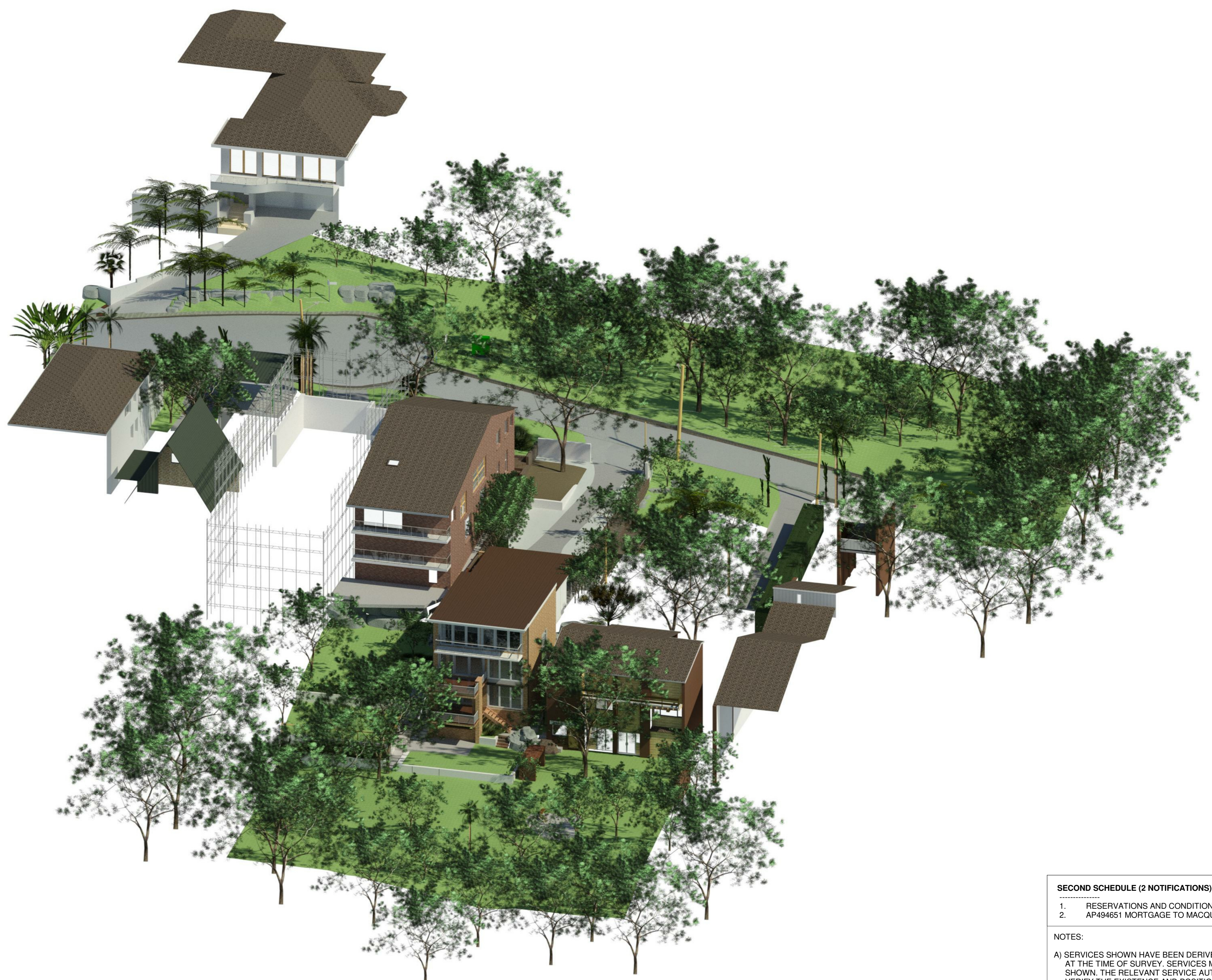

2 3D REAR VIEW
1:1

LEGEND:

AHD	AUSTRALIAN HEIGHT DATUM	PAV	PAVERS
AWN	AWNING	PP	POWER POLE
BM	BENCH MARK	RL	REDUCED LEVEL
CONC	CONCRETE	RR	ROOF RIDGE
CS	CONCRETE SURFACE	SC	SERVICE COVER
DIHS	DIAMETER/HEIGHT/SPREAD	SV	STOP VALVE
D	DOOR	TEL	TELSTRA PIT
EC	EDGE OF CONCRETE	TK	TOP OF KERB
EG	EAVE & GUTTER	TW	TOP OF WALL
FL	FLOOR LEVEL	V	VEHICLE CROSSING
GDN	GARDEN	VC	VEHICLE CROSSING
HYD	HYDRANT	WM	WATER METER
IL	INVERT LEVEL	WS	WINDOW SILL
LH	LAMP POLE	WT	TOP OF WINDOW
NS	NATURAL SURFACE		

NOTE: THIS SURVEY WAS COMPLETED USING LASER SCANNING TECHNOLOGY AND CONVENTIONAL SURVEY EQUIPMENT. THE DATA WAS ACCURATE AT TIME OF SURVEY.

SECOND SCHEDULE (2 NOTIFICATIONS) AS SEARCHED ON 01/11/2023

- RESERVATIONS AND CONDITIONS IN THE CROWN GRANT(S)
- AP494651 MORTGAGE TO MACQUARIE BANK LIMITED

NOTES:

A) SERVICES SHOWN HAVE BEEN DERIVED FROM VISUAL EVIDENCE APPARENT AT THE TIME OF SURVEY. SERVICES MAY EXIST WHICH ARE NOT SHOWN. THE RELEVANT SERVICE AUTHORITY SHOULD BE CONTACTED TO VERIFY THE EXISTENCE AND POSITION OF SERVICES PRIOR TO THE COMMENCEMENT OF ANY CONSTRUCTION OR EXCAVATION.

B) DIAMETER, HEIGHT & SPREAD OF TREES ARE APPROXIMATE ONLY.

C) LEVELS SHOWN ARE OF AUSTRALIAN HEIGHT DATUM.

D) USE STATED DIMENSIONS. DO NOT SCALE.

E) THESE NOTES FORM PART OF THIS PLAN AND CANNOT BE REMOVED.

F) NO COVENANTS AND/OR RESTRICTIONS HAVE BEEN INVESTIGATED BY C & A SURVEYORS PTY LTD.

THIS PLAN AND THE INFORMATION CONTAINED HEREIN REMAINS THE PROPERTY OF C & A SURVEYORS NSW PTY LTD. IT MUST NOT BE COPIED IN WHOLE OR PART, AND IS NOT TO BE USED FOR ANY PURPOSE OTHER THAN FOR THAT WHICH IT HAS BEEN PREPARED. WITHOUT WRITTEN CONSENT OF C & A SURVEYORS NSW PTY LTD. THIS PLAN HAS BEEN PREPARED FOR THE SOLE USE OF THE INSTRUCTING PARTY.

C & A SURVEYORS NSW P/L
Ph: 9630 9299
30 GROSE STREET,
PARRAMATTA NSW 2151
info@candasurveyors.com.au
www.candasurveyors.com.au

DETAIL & IDENTIFICATION SURVEY, FLOOR PLANS, ELEVATIONS & 3D MODEL OF LOT 15 SEC K ON DP2610 AT 5 BARRABOOK STREET CLONTAF

INSTRUCTING PARTY: SQUILLACE ARCHITECTURE - RYAN

Revision No.	Description	Date
01	DETAIL/IDENT SURVEY, FLOOR PLANS, ELEVATIONS & 3D MODEL	13/11/2023
02		
03		
04		

NOTES ON SURVEY

- THE IDENTIFICATION COMPONENT OF THIS SURVEY SHOWING DISTANCES BETWEEN STRUCTURES AS SURVEYED AND CADASTRAL BOUNDARIES HAS BEEN CONDUCTED IN ACCORDANCE WITH CLAUSE 10 OF THE SURVEYING AND SPATIAL INFORMATION REGULATION 2017.
- THE 2D & 3D DETAIL AND MODELLING COMPONENT OF THIS SURVEY HAS BEEN CONDUCTED IN ACCORDANCE WITH CLAUSE 9 OF THE SURVEYING AND SPATIAL INFORMATION REGULATION 2017.

DATUM:	AHD	SURVEYED BY:	B/JG/TS
SURVEY DATE:	02/11/2023	DRAWN BY:	MZ/AH
DATE DRAWN:	03/11/2023	SCALE:	1 : 1 @ A0
REFERENCE:	30921-23	SHEET:	7 OF 7