

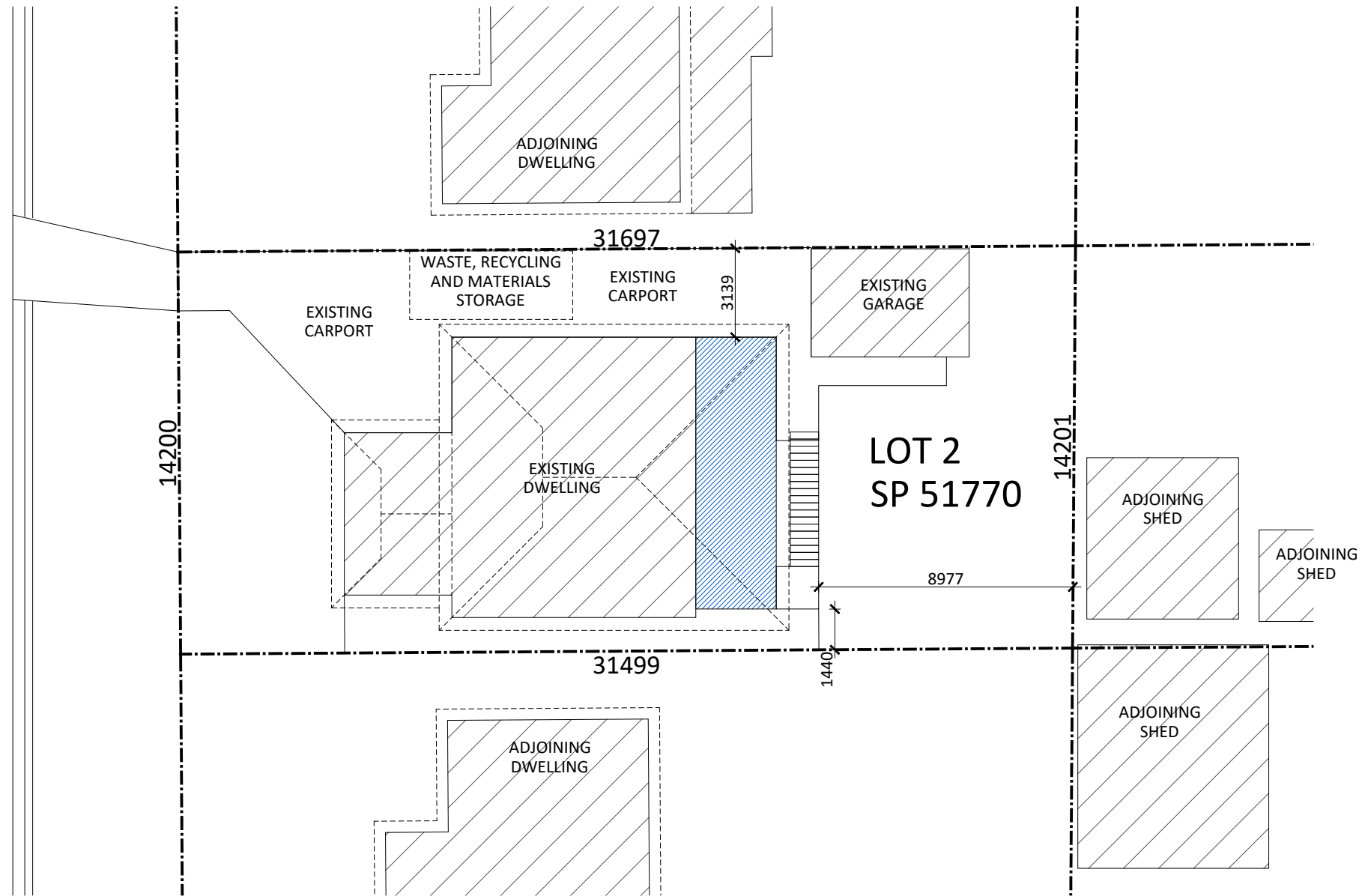

THIS PLAN IS TO BE READ IN CONJUNCTION WITH THE CONDITIONS OF DEVELOPMENT CONSENT

DA2024/0904

VICTOR ROAD



Sediment control fence details

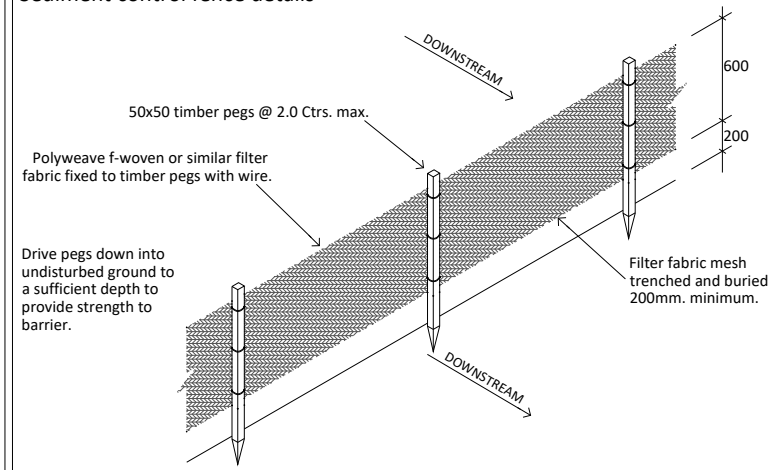

SITE ANALYSIS

TOTAL SITE AREA	448m ²
EXISTING DWELLING	107m ²
EXISTING DRIVEWAY & CONCRETE	103m ²
EXISTING GARAGE	21m ²
EXISTING DECK AND PATIO (to be replaced)	28m ²
TOTAL EXISTING IMPERVIOUS AREA	259m²
TOTAL AREA OF PROPOSED	28m ²
TOTAL NEW IMPERVIOUS AREA	0m ²
TOTAL PROPOSED IMPERVIOUS AREA	259m² (58%)
TOTAL PROPOSED LANDSCAPED AREA	189m² (42%)

ALL NEW BUILDING WORKS SHALL COMPLY WITH VOLUME 2 OF THE NATIONAL CONSTRUCTION CODE SERIES – BUILDING CODE OF AUSTRALIA (NCCS - BCA) 2020

SITE PLAN - SITE ANALYSIS

SCALE 1 : 200



DATE	AMENDMENT	ISSUE
25.05.23	SIDE SETBACK AMENDED	C
22.05.23	CDC ISSUE	B
11.05.23	PRELIMINARY ISSUE	A

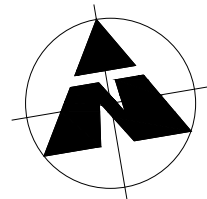

Copyright © This drawing remains the property of Urban Exteriors and may not be reproduced without prior consent. DO NOT SCALE from drawing. All dimensions are in millimetres and are to be verified on site prior to construction



11 Lipsia Place, Carlingford NSW 2118
Licence No: 274944c ABN: 22169612202
admin@urbanexteriors.com.au
P: 02 9872 7716 M: 0415 993 632

PROPOSED
REPLACEMENT SUNROOM
FOR CLIENT
MR. AND MRS. APTEKAR

AT SITE ADDRESS
**63A VICTOR STREET
DEE WHY 2099**
DRAWING
SITE PLAN - SITE ANALYSIS

LOT	DP	SEC
2	SP51770	
SCALE	DATE	DRAWN
1:200 (A3)	11.05.23	WM
JOB NO	DRAWING NO	SHEET NO
1749	1749 -01	1 OF 7

WINDOW SCHEDULE - to read in conjunction with basix certificate (refer basix page on plans)

No.	Sizes (H x W)	Glass type / Frame type	Shading Device	Orientation
W-01	2350 x 2700	Standard Aluminium - single - clear	Refer Basix Certificate	North
W-02	2350 x 2550	Standard Aluminium - single - clear		East
W-03	2350 x 2550	Standard Aluminium - single - clear		East
W-04	2350 x 2550	Standard Aluminium - single - clear		East
W-05	2350 x 1800	Standard Aluminium - single - clear		East
W-06	2350 x 2700	Standard Aluminium - single - clear		South

northern beaches council

THIS PLAN IS TO BE READ IN CONJUNCTION WITH THE CONDITIONS OF DEVELOPMENT CONSENT

DA2024/0904

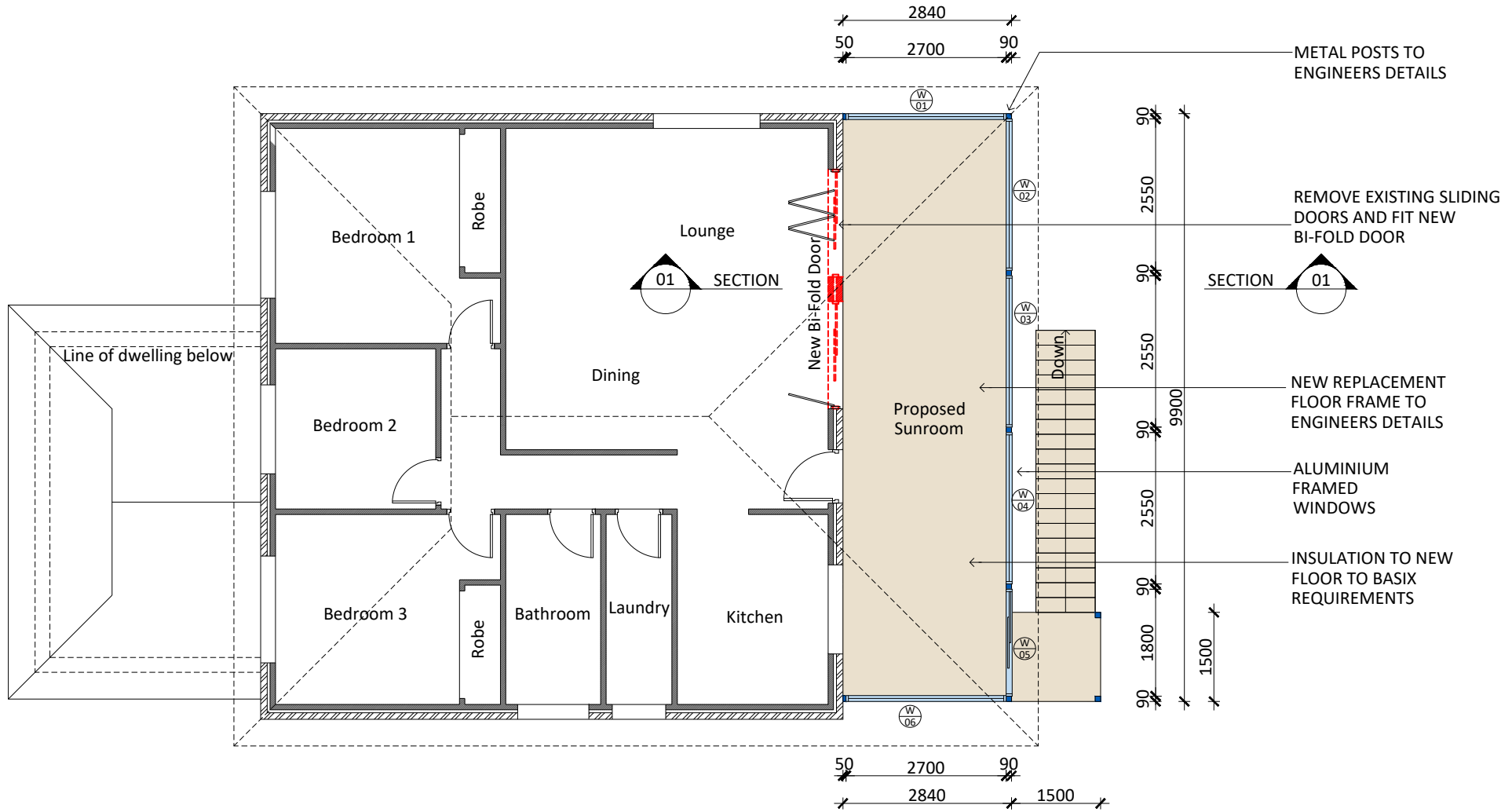

FLOOR SPACE RATIO

TOTAL SITE AREA	448m ²
EXISTING DWELLING (Grnd and 1st Flr)	204m ²
EXISTING FLOOR SPACE RATIO	0.45 : 1
PROPOSED SUNROOM	28m ²
TOTAL PROPOSED FLOOR AREA	232m ²
PROPOSED FLOOR SPACE RATIO	0.51 : 1



DATE	AMENDMENT	ISSUE
25.05.23	SIDE SETBACK AMENDED	C
22.05.23	CDC ISSUE	B
11.05.23	PRELIMINARY ISSUE	A

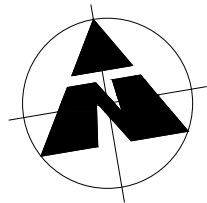

Copyright © This drawing remains the property of Urban Exteriors and may not be reproduced without prior consent. DO NOT SCALE from drawing. All dimensions are in millimetres and are to be verified on site prior to construction



11 Lipsia Place, Carlingford NSW 2118
 Licence No: 274944c ABN: 22169612202
admin@urbanexteriors.com.au
 P: 02 9872 7716 M: 0415 993 632

PROPOSED
REPLACEMENT SUNROOM
 FOR CLIENT
MR. AND MRS. APTEKAR

AT SITE ADDRESS
**63A VICTOR STREET
 DEE WHY 2099**
 DRAWING
FLOOR PLAN

LOT	DP	SEC
2	SP51770	
SCALE	DATE	DRAWN
1:100 (A3)	11.05.23	WM
JOB NO	DRAWING NO	SHEET NO
1749	1749 -04	4 OF 7

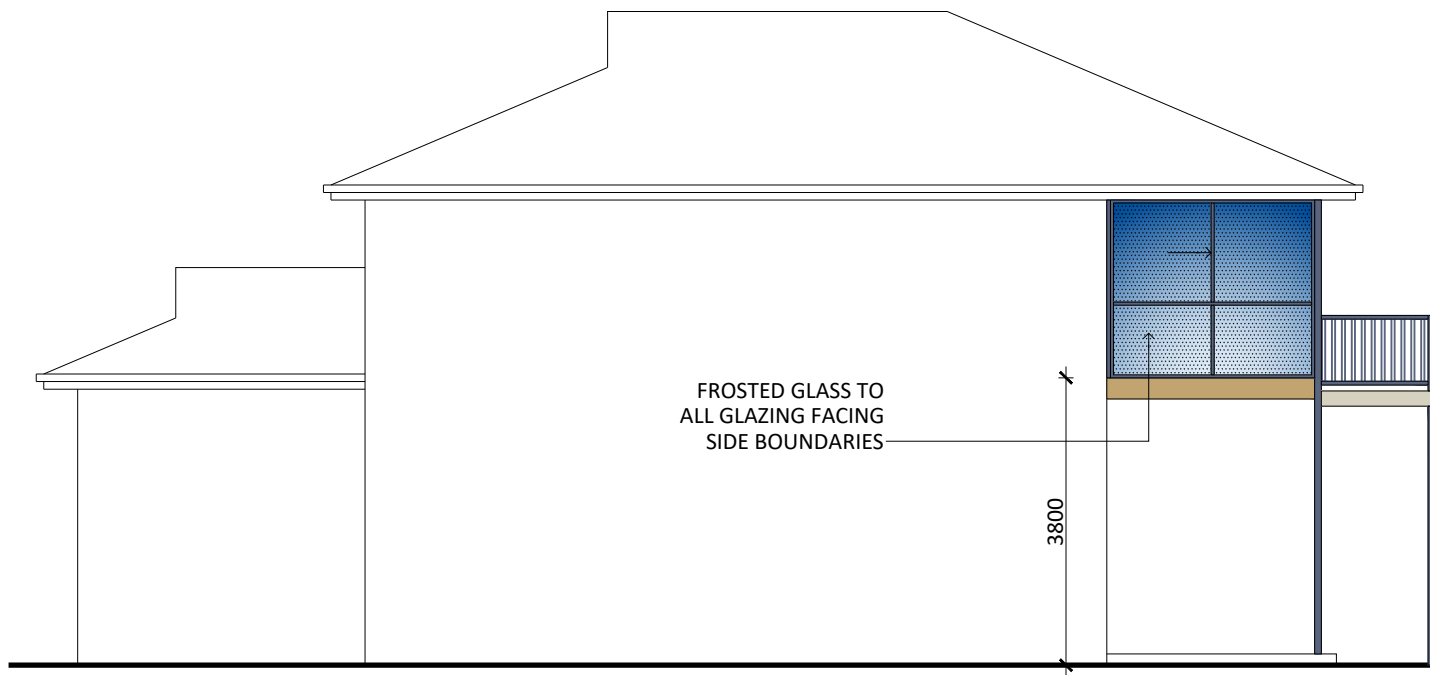

SOUTH ELEVATION - SIDE
SCALE 1 : 100

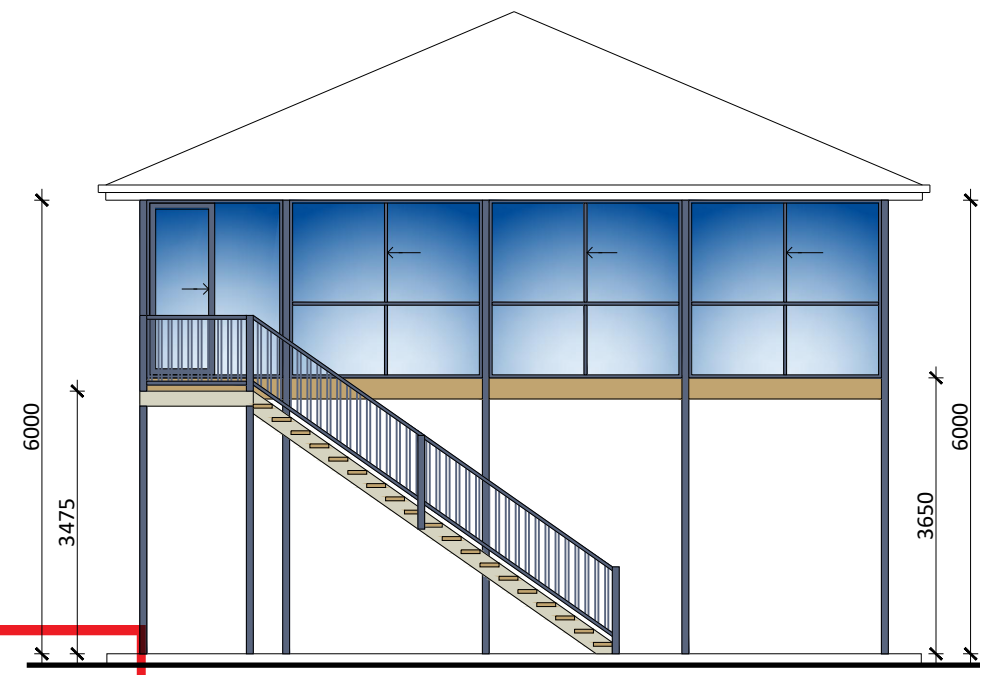

EAST ELEVATION - REAR
SCALE 1 : 100

 northern beaches council
THIS PLAN IS TO BE READ IN CONJUNCTION WITH THE CONDITIONS OF DEVELOPMENT CONSENT
DA2024/0904

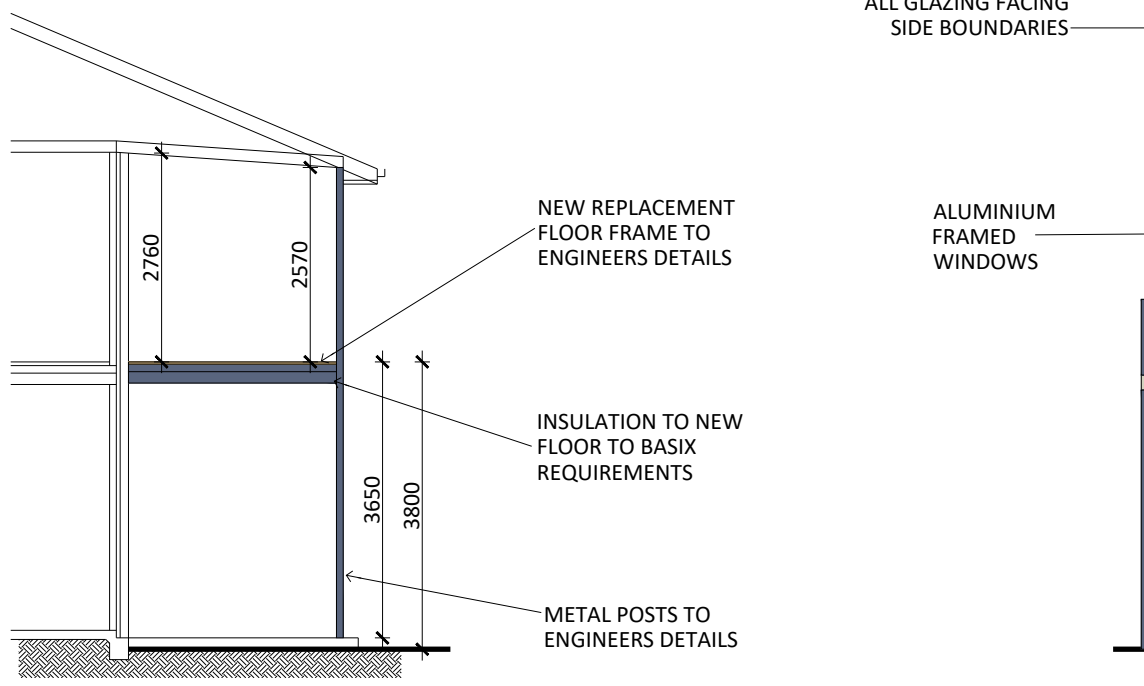

SECTION 01 - 01
SCALE 1 : 100

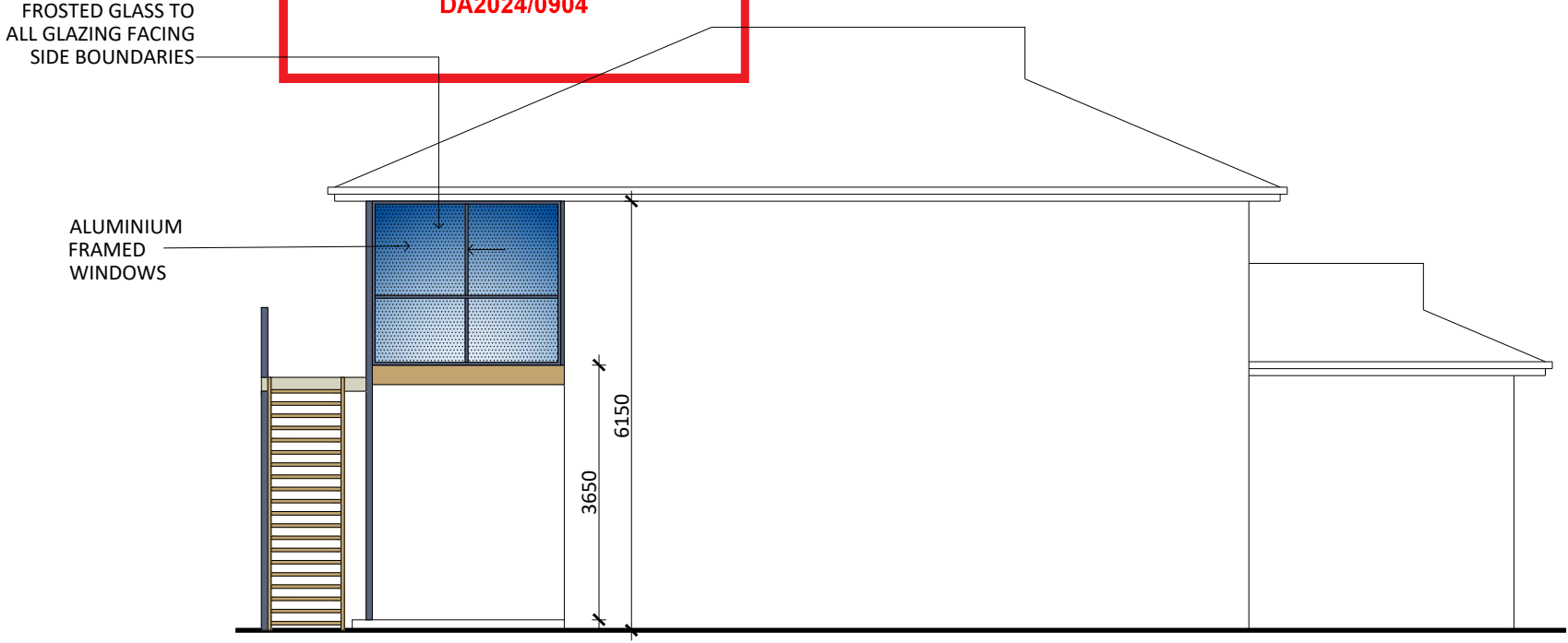

NORTH ELEVATION - SIDE
SCALE 1 : 100

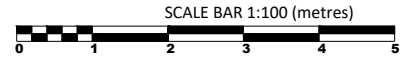

DATE	AMENDMENT	ISSUE
25.05.23	SIDE SETBACK AMENDED	C
22.05.23	CDC ISSUE	B
11.05.23	PRELIMINARY ISSUE	A

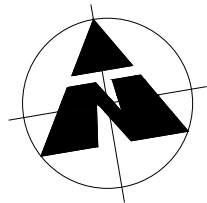

Copyright © This drawing remains the property of Urban Exteriors and may not be reproduced without prior consent. DO NOT SCALE from drawing. All dimensions are in millimetres and are to be verified on site prior to construction



11 Lipsia Place, Carlingford NSW 2118
 Licence No: 274944c ABN: 22169612202
admin@urbanexteriors.com.au
 P: 02 9872 7716 M: 0415 993 632

PROPOSED
REPLACEMENT SUNROOM
 FOR CLIENT
MR. AND MRS. APTEKAR

AT SITE ADDRESS
**63A VICTOR STREET
 DEE WHY 2099**
 DRAWING
SECTION AND ELEVATIONS

LOT	DP	SEC
2	SP51770	
SCALE	DATE	DRAWN
1:100 (A3)	11.05.23	WM
JOB NO	DRAWING NO	SHEET NO
1749	1749 -05	5 OF 7