

**NOTE SERVICES**  
 APPROXIMATE LOCATIONS OF EXISTING SERVICES SHOWN EXACT LOCATIONS & DEPTHS TO BE ACCURATELY LOCATED BY BUILDER CONTRACTOR BY CONTACTING THE RELEVANT AUTHORITIES BEFORE COMMENCEMENT OF ANY WORKS

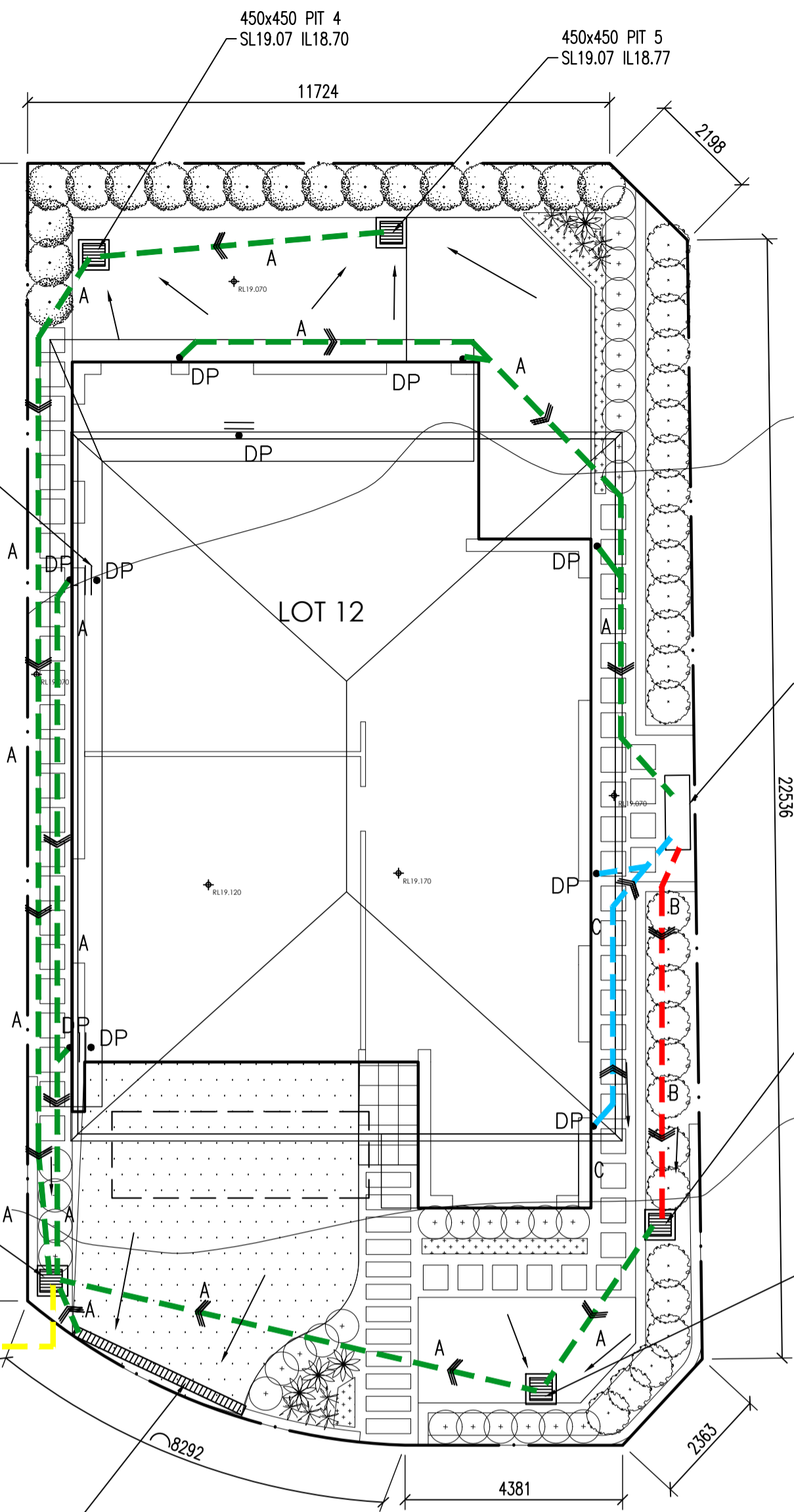

**NOTE: BASIC REQUIREMENTS**  
 ENSURE MINIMUM ROOF CATCHMENT AREA DRAINS TO ABOVE GROUND RAINWATER TANK. REFER BASIC REPORT AND REQUIREMENTS

**NOTE: BASIC REQUIREMENTS**  
 MINIMUM RAINWATER TANK CAPACITY = 2000L  
 PROVIDED RAINWATER TANK CAPACITY = 3000L  
 MINIMUM COLLECTED ROOF RUNOFF = 90sqm  
 PROVIDED COLLECTED ROOF RUNOFF = 134sqm

**NOTE: FOR OWNER/BUILDER/PLUMBER**  
 REGULAR 2 MONTHLY MAINTENANCE IS REQUIRED TO ALL PITS. OWNER/BUILDER/TENANT TO ENSURE ALL PITS ARE CLEANED.

LEGEND	
RL 00.000	NEW REDUCED LEVEL
GFL 00.00	GROUND FLOOR LEVEL
FFL 00.00	FINISH FLOOR LEVEL
A,B,C,D, etc.	REFER TO PIPE SCHEDULE
L1	PIPE LABEL
PIT P1	SURFACE INLET PIT
● DP	DOWNPIPE
□ RW	RAIN WATER HEAD
[Symbol]	PIT: SIZE AS MARKED
[Symbol]	SEALED PIT: SIZE AS MARKED
[Symbol]	W:200mm x D:200mm GRATED DRAIN
[Symbol]	GROUND FALL
[Symbol]	OVERLAND FLOW
[Symbol]	100mm UPVC CHARGED LINE
[Symbol]	DRAINAGE PIPE IN GROUND
[Symbol]	RAINWATER TANK OVERFLOW PIPE
[Symbol]	EXISTING DRAINAGE OUTLET PIPE

- NOTES**
- THESE DRAWINGS ARE TO BE READ IN CONJUNCTION WITH THE ARCHITECTURAL DRAWINGS, STRUCTURAL DRAWINGS AND THE SPECIFICATION.
  - PRIOR TO COMMENCEMENT OF WORKS THE CONTRACTOR SHALL SATISFY HIMSELF OF THE CORRECT LOCATION OF EXISTING SERVICES WHETHER INDICATED OR NOT ON THE PLANS. ANY DAMAGE TO EXISTING SERVICES SHALL BE RECTIFIED AT THE CONTRACTOR'S EXPENSE.
  - TRAFFIC MANAGEMENT MEASURES HAVE TO BE IMPLEMENTED AND MAINTAINED DURING CONSTRUCTION, ALL IN ACCORDANCE WITH COUNCIL'S REQUIREMENTS. THE CONTRACTOR SHALL MAINTAIN SAFE PEDESTRIAN ACCESS ALONG THE FOOTPATH.
  - THE CONTRACTOR SHALL EFFECT TEMPORARY DRAINAGE MEASURES TO AVOID LOCALISED PONDING OF SURFACE RUN-OFF.
  - REFER TO ARCHITECT'S DRAWINGS FOR ALL DETAILS (LEVELS, GRADING ETC.) OF DRIVEWAYS, CONCRETE AND PAVED AREAS, AND RETAINING WALL TYPES AND LOCATIONS.
  - REFER TO LANDSCAPE ARCHITECT'S DRAWINGS FOR DETAILS AND EXTENT OF ALL LANDSCAPED AREAS.
  - ALL SWD PIPES ARE UPVC AT 1.0% MINIMUM GRADE (UNO).
  - SWD PITS CAN BE PRE-CAST SIZED AS FOLLOWS:  
 450mm SQ. UP TO 600mm DEEP  
 600mm SQ. UP TO 1000mm DEEP
  - ALL PITS LOCATED IN TRAFFICABLE AREAS, (IE, DRIVEWAYS) TO HAVE MEDIUM DUTY GRATED COVERS SUITABLE FOR WITHSTANDING LOADS ASSOCIATED WITH SMALL TRUCKS.
  - PROVIDE STEP IRONS TO ALL PITS GREATER THAN 1.2m DEEP.
  - THE CONTRACTOR SHALL IMPLEMENT ALL SOIL EROSION AND SEDIMENT CONTROL MEASURES PRIOR TO COMMENCEMENT OF WORKS.
  - TOPSOIL SHALL BE STRIPPED DN STOCKPILED OUTSIDE HAZARD AREAS SUCH AS DRAINAGE LINES. THIS TOPSOIL IS TO BE RESPREAD LATER ON AREAS TO BE REVEGETATED.
  - THE CONTRACTOR SHALL REGULARLY MAINTAIN ALL SEDIMENT AND EROSION CONTROL DEVICES AND REMOVE ACCUMULATED SILT FROM SUCH DEVICES. ALL SILT REMOVED SHALL BE DISPOSED OF AS DIRECTED BY THE SUPERINTENDENT. THE PERIOD FOR MAINTAINING THESE DEVICES SHALL BE AT LEAST UNTIL ALL DISTURBED AREAS ARE REVEGETATED AND FURTHER AS MAY BE DIRECTED BY THE SUPERINTENDENT OR COUNCIL.
  - THE CONTRACTOR SHALL MAINTAIN DUST CONTROL UNTIL FINAL COMPLETION OF WORKS.

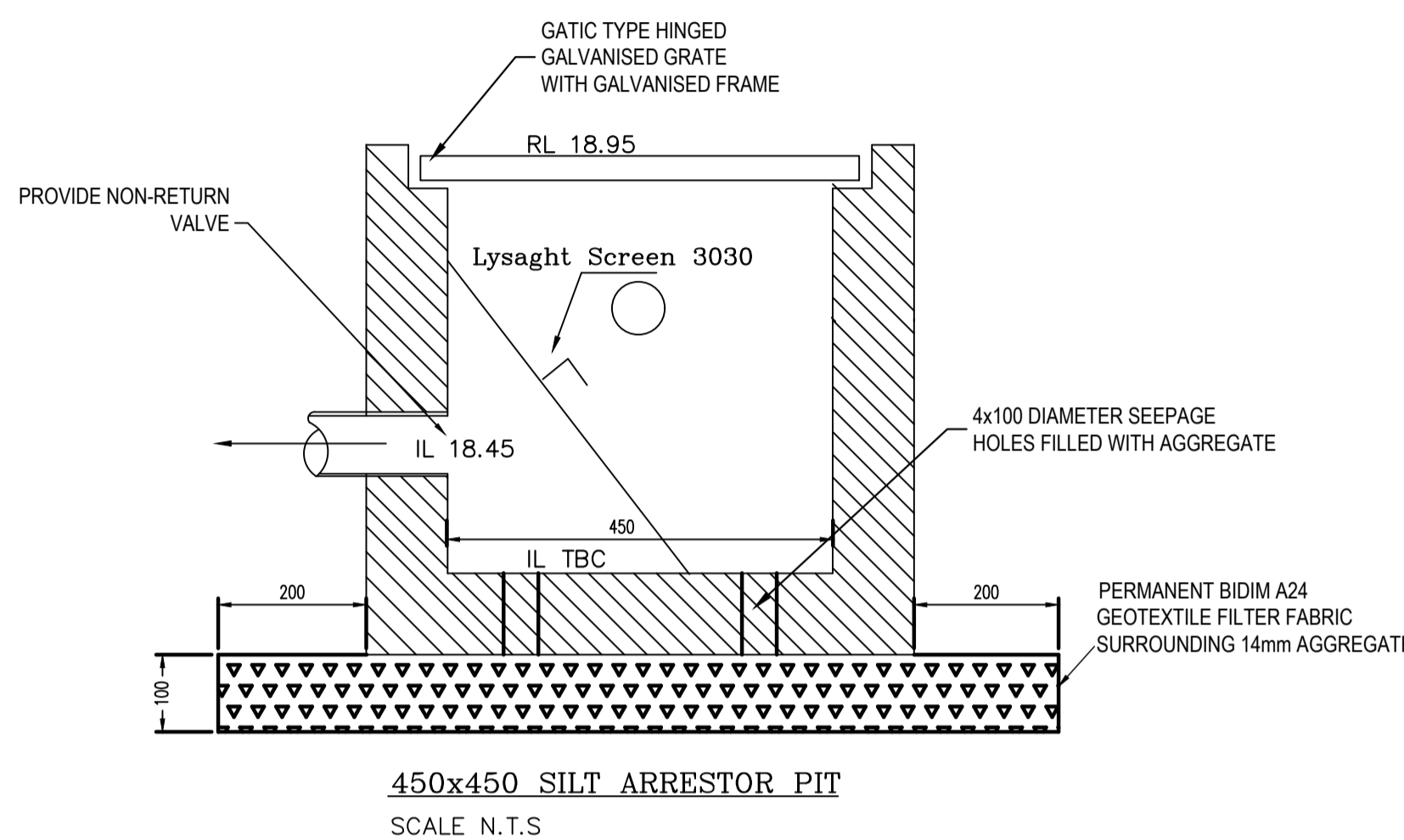

PIPE SCHEDULE TO ALL GUTTERS			
TAG	PIPE Ø	MATERIAL	Min. GRADE
A	100	PVC	1%
B	100 OVERFLOW	PVC	1%
C	100 CHARGED	PVC	-
DP	100	PVC	-

**DRAINAGE LAYOUT PLAN**  
 SCALE : 1:100

**RAINWATER TANK NOTES:**  
 RAINWATER TANK AND PIPE WORK IS TO BE PAINTED IN COLOURS MATCHING THE EXTERNAL FINISHES OF THE DWELLING AND IS TO BE NON-REFLECTIVE FINISH.

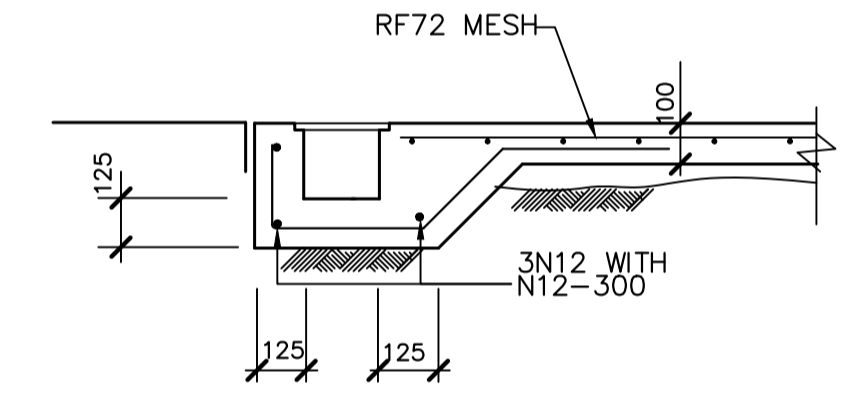

GRATED DRAIN

**DANGER**

WHEN EXCAVATING WITHIN ANY SITE, FOOTPATH AND ROADWAY, ALL SERVICES SHALL BE LOCATED PRIOR TO COMMENCEMENT OF THE EXCAVATION WORKS.

CONTACT "DIAL BEFORE YOU DIG" ON PHONE No. 1100 OR GO TO THE WEB SITE

"www.dialbeforeyoudig.com.au"

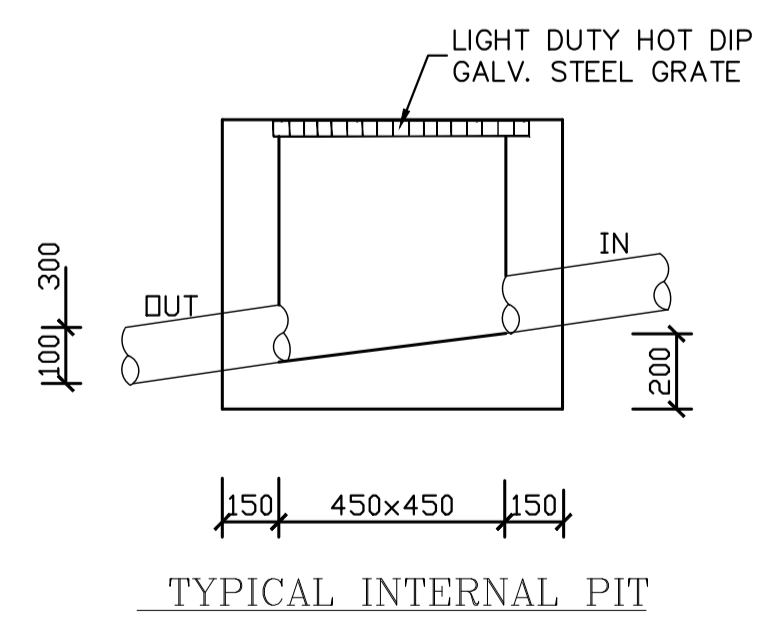

TYPICAL INTERNAL PIT

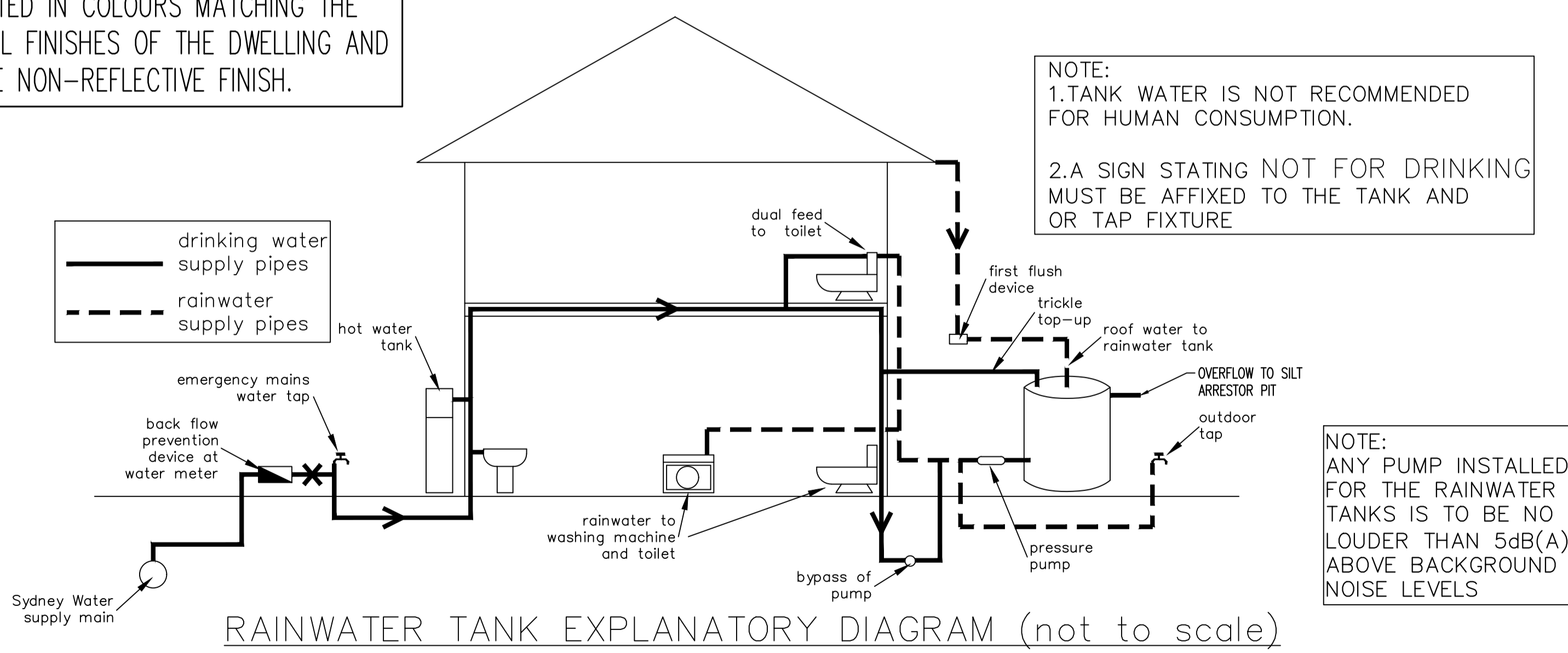

**NOTE:**  
 1. TANK WATER IS NOT RECOMMENDED FOR HUMAN CONSUMPTION.  
 2. A SIGN STATING NOT FOR DRINKING MUST BE AFFIXED TO THE TANK AND OR TAP FIXTURE

**NOTE:**  
 ANY PUMP INSTALLED FOR THE RAINWATER TANKS IS TO BE NO LOUDER THAN 5dB(A) ABOVE BACKGROUND NOISE LEVELS

RAINWATER TANK EXPLANATORY DIAGRAM (not to scale)

REVISION	AMENDMENT	ISSUE DATE	ISSUE	ISSUED TO	ISSUE DATE
C	ISSUED FOR DA APPROVAL	04/11/2021			
B	ISSUED FOR DA APPROVAL	26/10/2021			
A	PRELIMINARY DESIGN	21/09/2021			

**CAM CONSULTING**  
 STRUCTURAL & CIVIL ENGINEERS

SUITE 303 / 29-31 LEXINGTON DRIVE  
 NORWEST BUSINESS PARK,  
 BELLA VISTA N.S.W. 2153

ALL CORRESPONDENCE TO:  
 P.O. BOX 6080 BAULKHAM HILLS BC  
 BAULKHAM HILLS NSW 2153

PH. 8814 6191 FAX 8814 5301 MOB. 0425 270 333  
 EMAIL. andrew@camconsulting.com.au

PROJECT  
**PROPOSED DEVELOPMENT  
 LOT 12, 10 FERN CREEK ROAD,  
 WORRIEWOOD, NSW**

CLIENT  
**SKYCORP**

ARCHITECT / PROJECT MANAGER  
**KAE CHAN**

DRAWING TITLE		
DRAINAGE LAYOUT PLAN		
SCALES A1 - 1:100	DESIGNED A.C.	DRAFTED M.W.
DRAWING NO. C21187-SW01	APPROVED A.C.	REVISION C



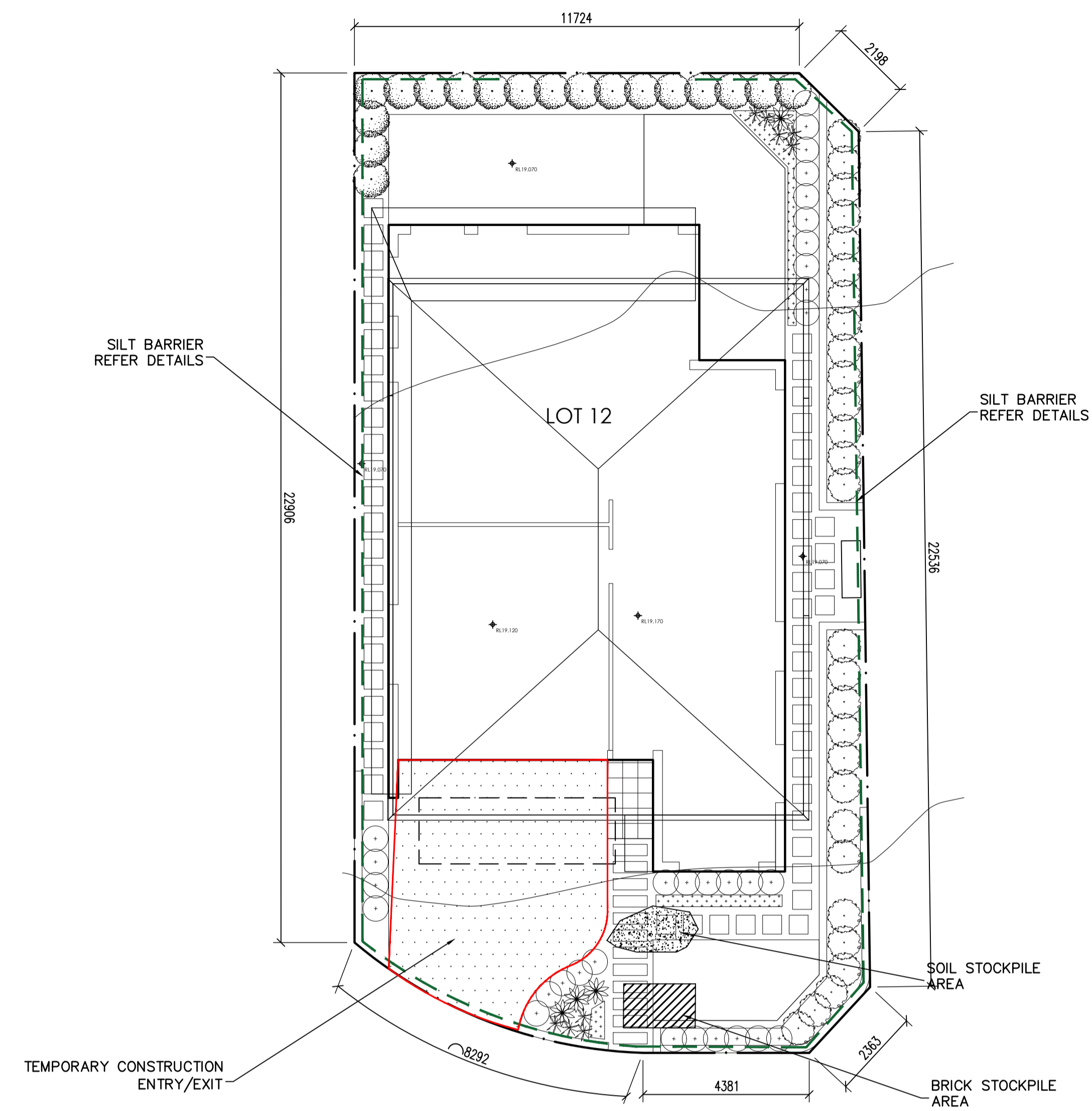

**SM SOIL MANAGEMENT PLAN**  
SCALE : 1:100

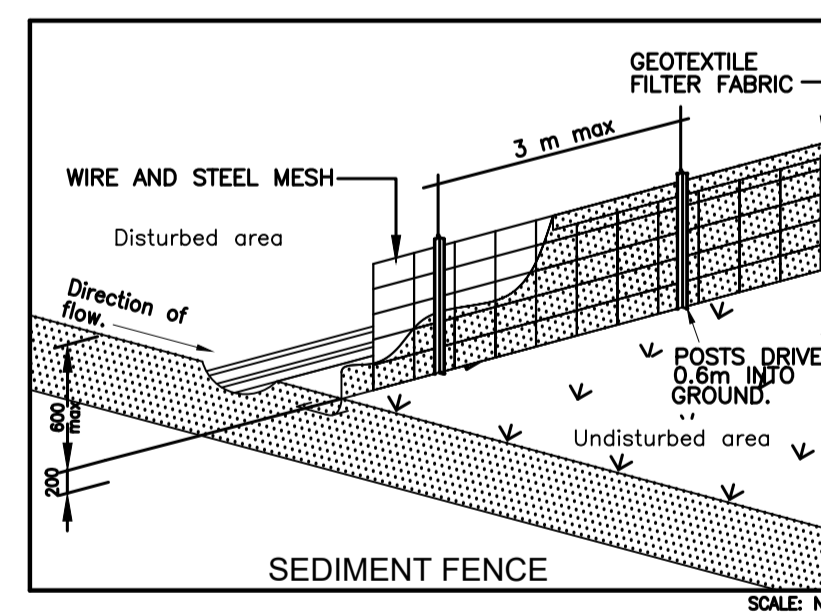
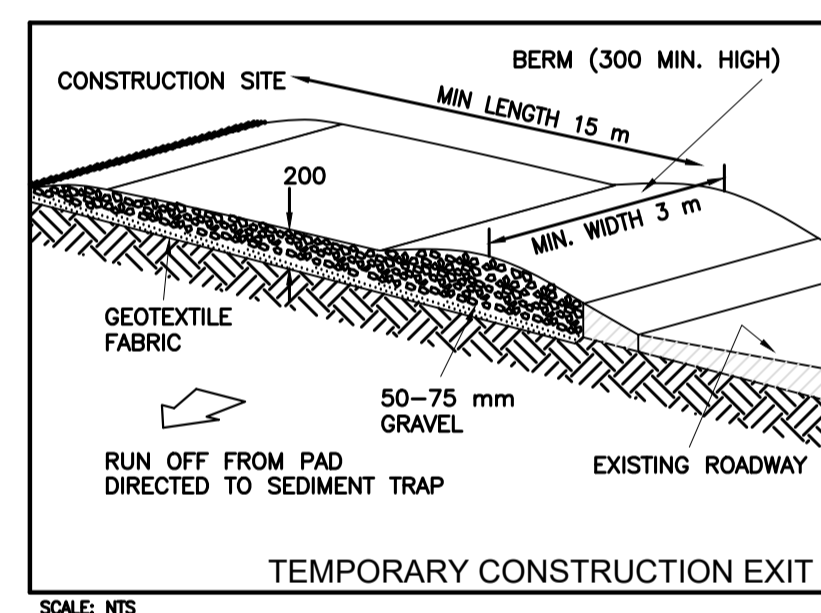
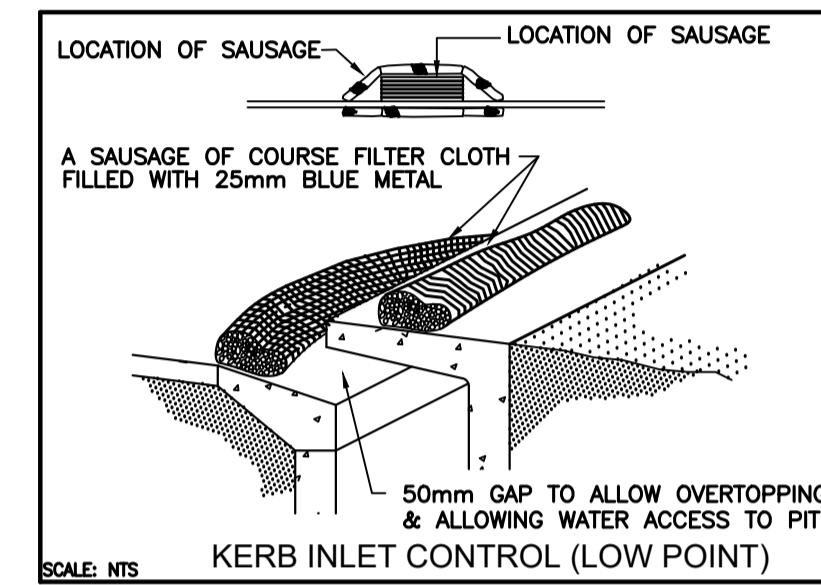
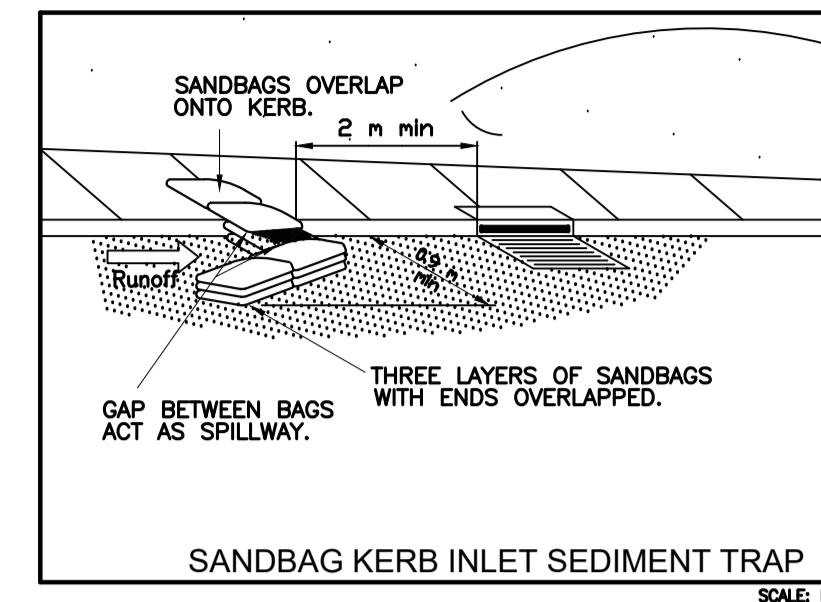
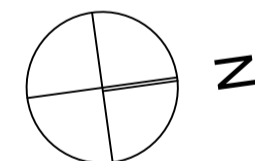

**SOIL EROSION CONTROL INSTRUCTIONS**

- EARTH BATTERS WILL BE CONSTRUCTED WITH AS LOW AS A GRADIENT AS PRACTICABLE BUT NO STEEPER, UNLESS OTHERWISE NOTED, THAN:
  - 2(H):1(V) WHERE SLOPE LENGTH LESS THAN 12 METRES
  - 2.5(H):1(V) WHERE SLOPE LENGTH BETWEEN 12 & 16 METRES
  - 3(H):1(V) WHERE SLOPE LENGTH BETWEEN 16 & 20 METRES
  - 4(H):1(V) WHERE SLOPE LENGTH GREATER THAN 20 METRES
- ALL WATERWAYS, DRAINS, SPILLWAYS AND THEIR OUTLETS WILL BE CONSTRUCTED TO BE STABLE IN AT LEAST THE 1:20 YEAR ARI, TIME OF CONCENTRATION STORM EVENT.
- WATERWAYS AND OTHER AREAS SUBJECT TO CONCENTRATED FLOWS AFTER CONSTRUCTION ARE TO HAVE A MAXIMUM GROUND COVER C-FACTOR OF 0.05 (70% GROUND COVER) WITHIN 10 WORKING DAYS FROM COMPLETION OF FORMATION. FLOW VELOCITIES ARE TO BE LIMITED TO THOSE SHOWN IN TABLE 5-1 OF "MANAGING URBAN STORMWATER - SOILS AND CONSTRUCTION DEPT OF HOUSING 1998 (BLUE BOOK). FOOT AND VEHICULAR TRAFFIC WILL BE PROHIBITED IN THESE AREAS.
- STOCKPILES AFTER CONSTRUCTION ARE TO HAVE A MAXIMUM GROUND COVER C-FACTOR OF 0.1 (60% GROUND COVER) WITHIN 10 WORKING DAYS FROM COMPLETION OF FORMATION.
- ALL LANDS, INCLUDING WATERWAYS AND STOCKPILES, DURING CONSTRUCTION ARE TO HAVE A MAXIMUM GROUND COVER C-FACTOR OF 0.15 (50% GROUND COVER) WITHIN 20 WORKING DAYS FROM INACTIVITY EVEN THOUGH WORKS MAY CONTINUE LATER.
- FOR AREAS OF SHEET FLOW USE THE FOLLOWING GROUND COVER PLANT SPECIES FOR TEMPORARY COVER: JAPANESE MILLET 20KG/HA AND OATS.
- PERMANENT REHABILITATION OF LANDS AFTER CONSTRUCTION WILL ACHIEVE A GROUND COVER C-FACTOR OF LESS THAN 0.1 AND LESS THAN 0.05 WITHIN 60 DAYS. NEWLY PLANTED LANDS WILL BE WATERED REGULARLY UNTIL AN EFFECTIVE COVER IS ESTABLISHED AND PLANTS ARE GROWING VIGOROUSLY FOLLOW-UP SEED AND FERTILISER WILL BE APPLIED AS 20KG/HA
- REVEGETATION SHOULD BE AIMED AT RE-ESTABLISHING NATURAL SPECIES. NATURAL SURFACE SOILS SHOULD BE REPLACED AND NON-PERSISTANT ANNUAL COVER SPROPS SHOULD BE USED.

**DUST CONTROL INSTRUCTIONS**

- ALL STOCKPILED MATERIAL OR SEDIMENT COLLECTION TO BE SPRAYED BY LIGHTLY WIDE ANGLED WATER
- THIS TEMPORARY MECHANICAL METHOD CONFINES AND SETTLES THE DUST FROM THE AIR BY DUST AND WATER PARTICLE ADHESION. WATER IS SPRAYED THROUGH NOZZELS OVER THE PROBLEM AREA.

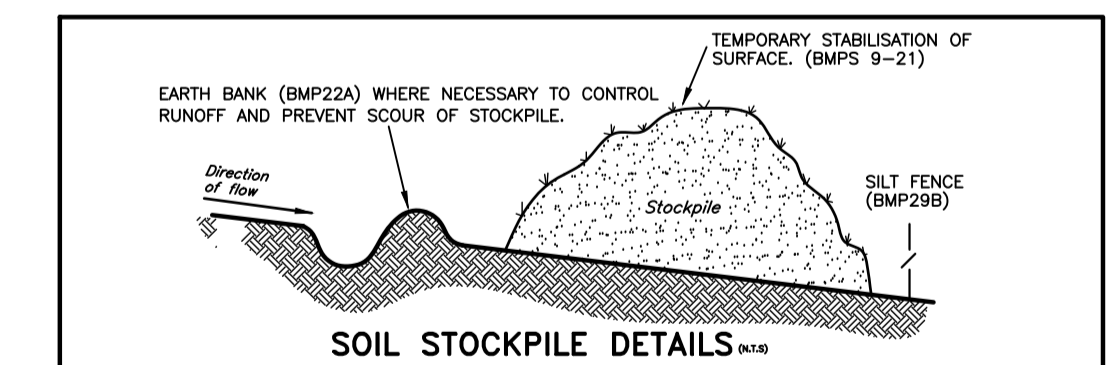

SUITE 303 / 29-31 LEXINGTON DRIVE  
NORWEST BUSINESS PARK,  
BELLA VISTA N.S.W. 2153  
ALL CORRESPONDENCE TO:  
P.O. BOX 6080 BAULKHAM HILLS BC  
BAULKHAM HILLS NSW 2153  
PH. 8814 6191 FAX 8814 5301 MOB. 0425 270 333  
EMAIL. andrew@camconsulting.com.au

PROJECT  
PROPOSED DEVELOPMENT  
LOT 12, 10 FERN CREEK ROAD,  
WORRIEWOOD, NSW  
CLIENT  
SKYCORP  
ARCHITECT / PROJECT MANAGER  
KAE CHAN

DRAWING TITLE  
SOIL MANAGEMENT PLAN

SCALES A1 - 1:100	DESIGNED A.C.	DRAFTED M.W.
DRAWING NO. C21187-SW02	APPROVED A.C.	REVISION C

REVISION	AMENDMENT	ISSUE DATE	ISSUE	ISSUED TO	ISSUE DATE
C	ISSUED FOR DA APPROVAL	04/11/2021			
B	ISSUED FOR DA APPROVAL	26/10/2021			
A	PRELIMINARY DESIGN	21/09/2021			