



ICONHOMES.COM.AU

Karinya

Lot Number: 20

DP Number: UNREG



Accurate

design and drafting

Office: 1a/10 Exchange Parade
Narellan NSW 2567

Phone : 0246472552

Email: info@accuratedesign.com.au

Icon Job Number: J/0343

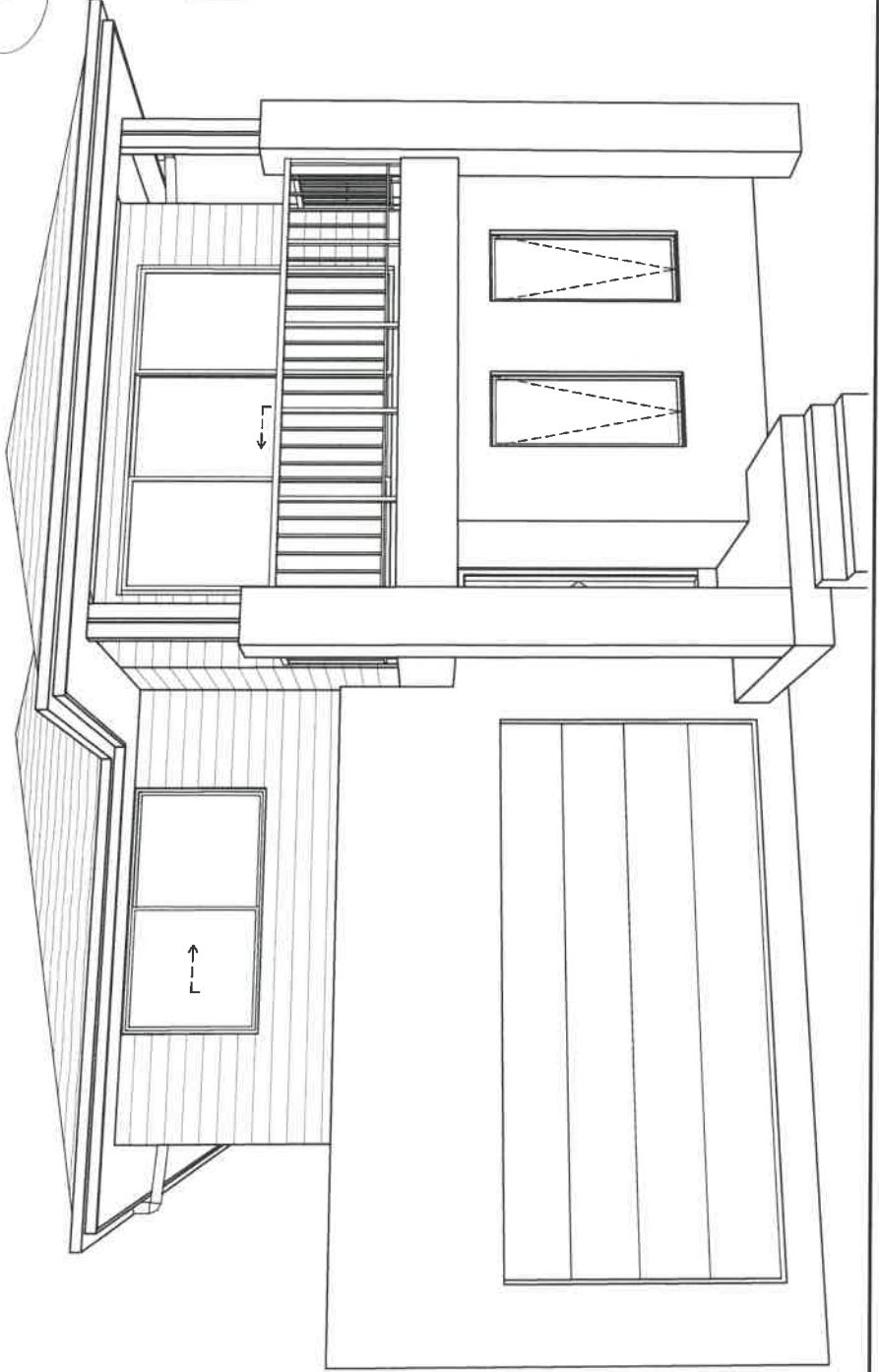

Client Approval:	Date:
Job:	Proposed B/V Residence
Drawing:	Perspective View
Scale:	-
Date:	06-09-18
Drawing No:	18006-10
Sheet:	2/12
Issue:	K
© abeaut designs / a Accurate Design and Drafting 2018	

Notes:

- Levels shown are approx and should be verified on site
- Dimensions are to be taken in preference to scaling
- All measurements are in mm unless otherwise stated
- Window sizes are nominal only. Final window sizes before commencement of work.
- Dimensions are to be verified on site by builder
- All upstairs windows with a sill height less than 1700mm to have a max opening width of 125mm or fitted with a screen with secure fittings to comply with BCA
- Final AJ's to engineers specifications
- Plus or minus 200mm to floor levels
- Steel beam required if any openings have more than 6 courses of brickwork above

Icon Job Number: J/0343



Client Approval: _____ Date: _____

Job: **Proposed B/V Residence**
 LOT: 20 DP: UNREG
 Karinya

Drawing: **Elevations**

Scale: **1:100** Date: **06-09-18**

Drawing No: **18006-10** Sheet: **5/12** Issue: **K**

House Design: Custom

Accurate
 design and drafting
 Office: 1a/10 Exchange Parade
 Narellan NSW 2567
 Phone : 0246472552
 Email: info@accuratedesign.com.au

© abourr designs t/a Accurate Design and Drafting 2018

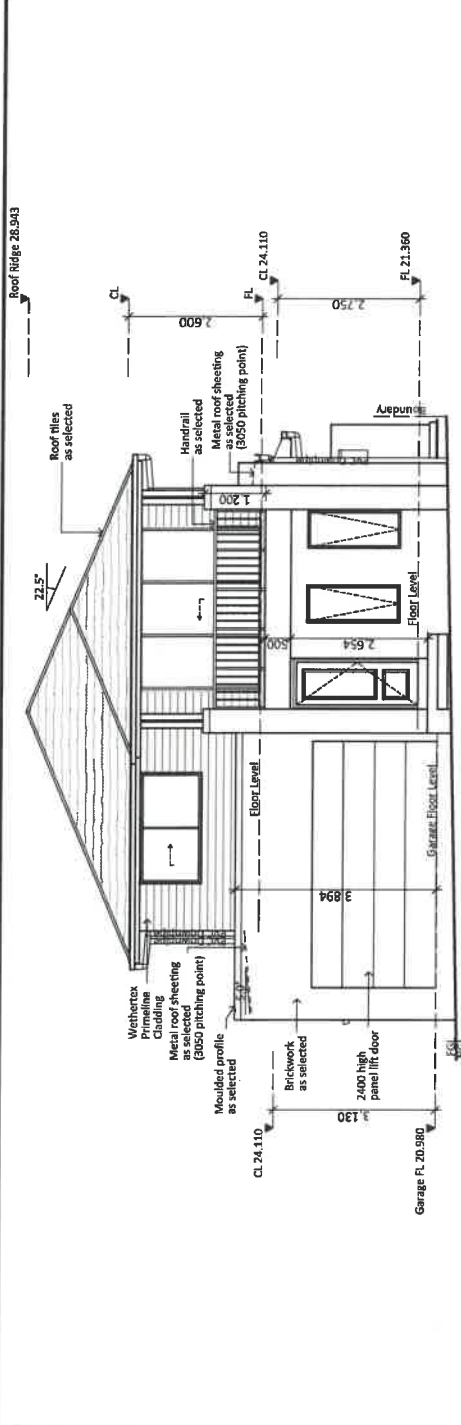

Front Elevation
1:100

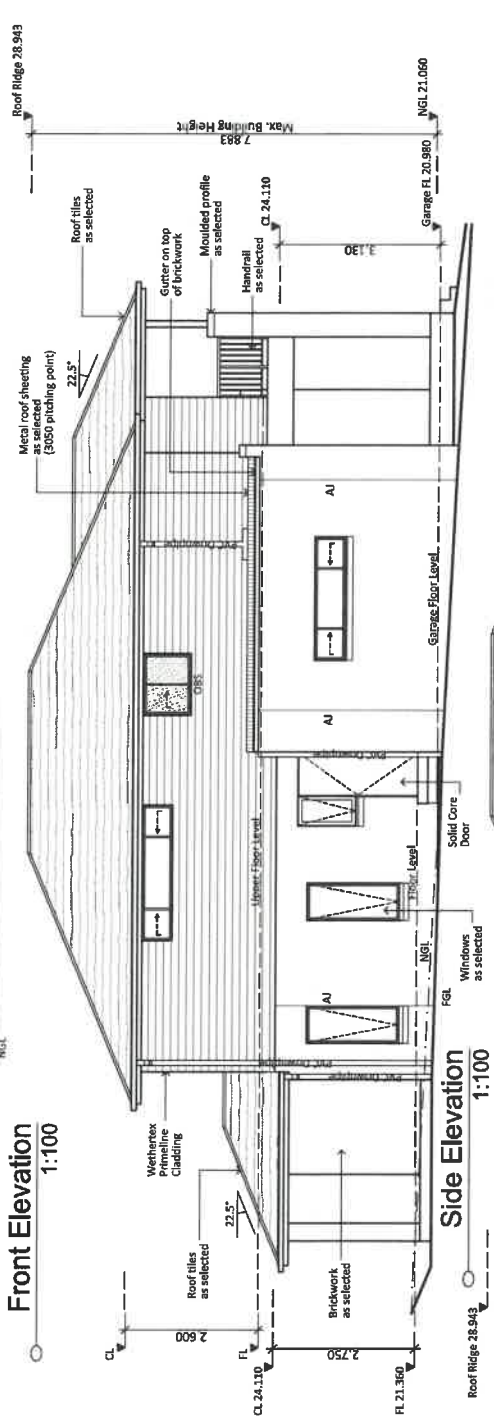

Side Elevation
1:100

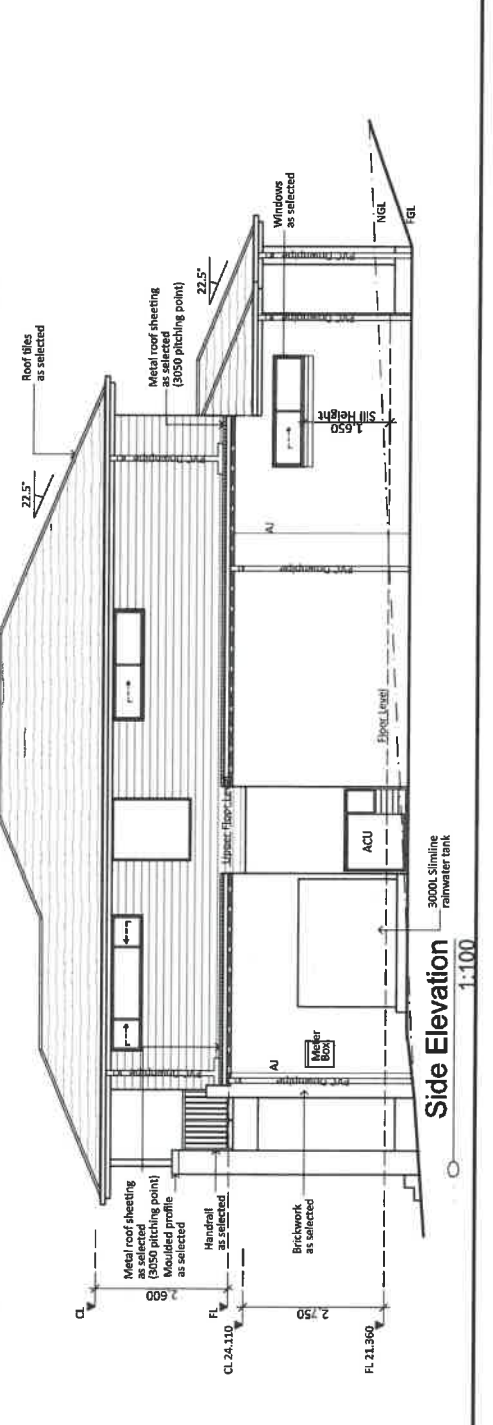

Side Elevation
1:100

- Legend:**
- ACU - Air Conditioning Unit
 - AJ - Articulation Joint
 - CL - Ceiling Line
 - CG - Floor Ceiling Line
 - FL - Floor Level
 - HWS - Hot Water System
 - NGL - Natural Ground Line
 - OP - Obsolete
 - DP - Door
 - RW - Retaining Wall

- Legend:**
- AC - Air Conditioning Unit
 - AJ - Articulation Joint
 - CL - Ceiling Level
 - FL - Finish Ground Line
 - HWS - Hot Water System
 - NGI - Natural Ground Line
 - DP - Downpipe
 - R/W - Retaining Wall

Notes:

1. Levels shown are approx and should be verified
2. Finished dimensions are to be taken in preference to scaling
3. All measurements are in mm unless otherwise stated
4. Window sizes are nominal only. Final window sizes to be verified on site by builder
5. Dimensions are to be verified on site by builder before commencement of work.
6. All upstairs windows with a sill height less than 1700mm to have a max opening width of 125mm or fitted with a screen with secure fittings to comply with BCA
7. Final AJ's to engineers specifications
8. Plus or minus 200mm to floor levels
9. Steel beam required if any openings have more than 6 courses of brickwork above

Icon Job Number: J/0343

Client Approval: _____ Date: _____

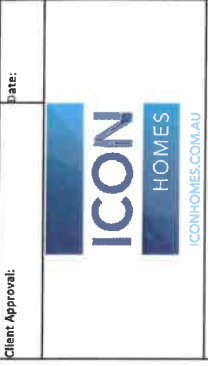

Job: **Proposed B/V Residence**
 LOT: 20 DP: UNREG
 Karinya

Drawing: **Elevation, Section & Details**

Scale: **1:100, 1:25** Date: **06-09-18**

Drawing No: **18006-10** Sheet: **6/12** Issue: **K**
 House Design: Custom

Accurate
 design and drafting
 Office: 1a/10 Exchange Parade
 Narellan NSW 2567
Phone : 0246472552
 Email: info@accuratedesign.com.au

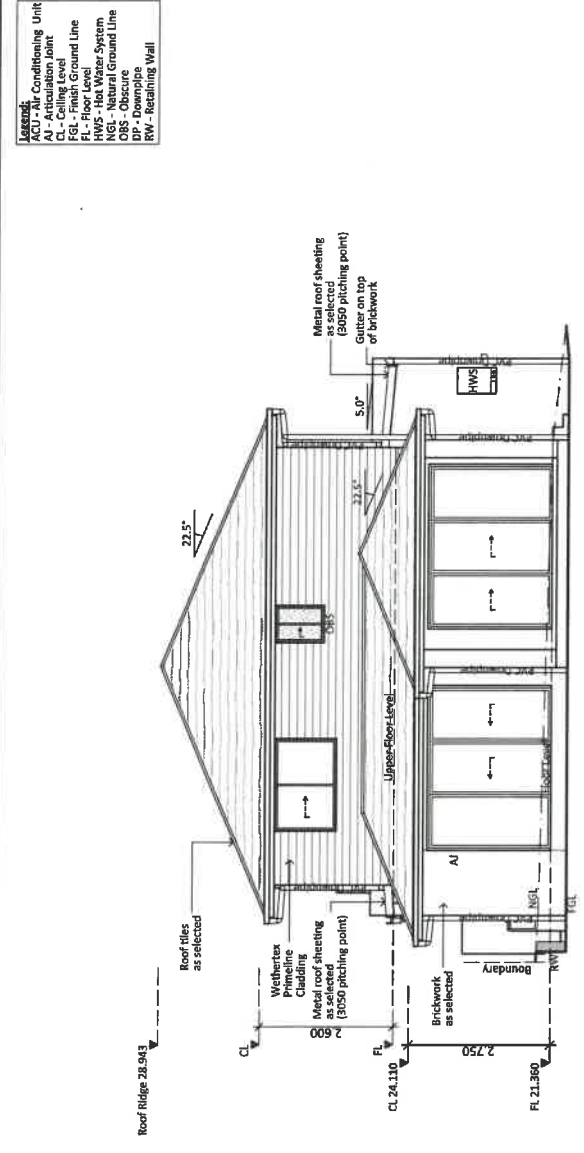

Rear Elevation
1:100

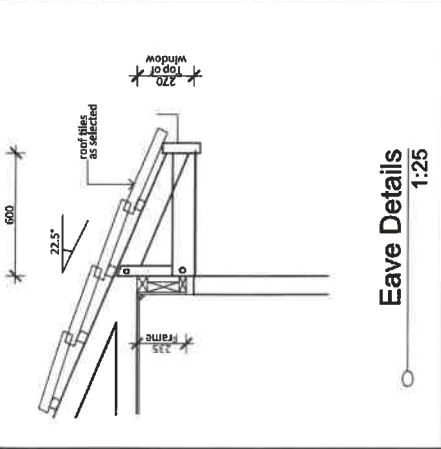

Eave Details
1:25

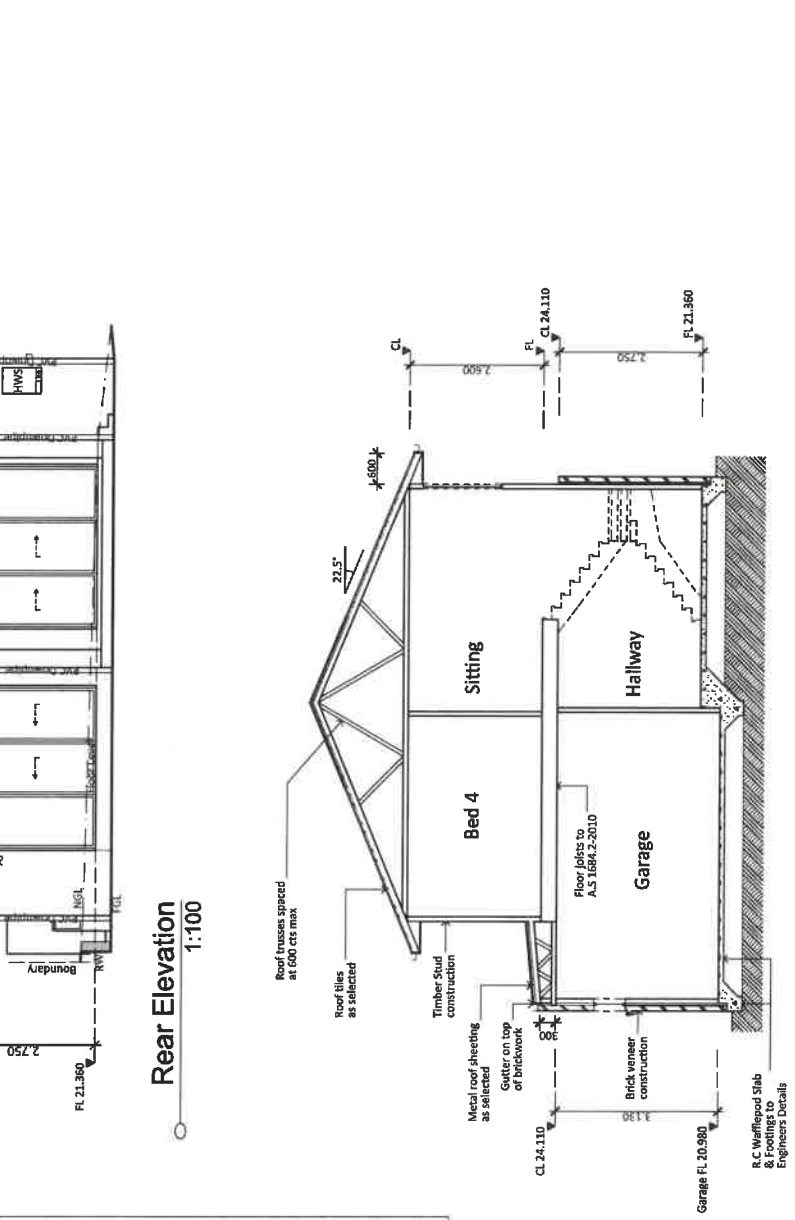

Section A-A
1:100

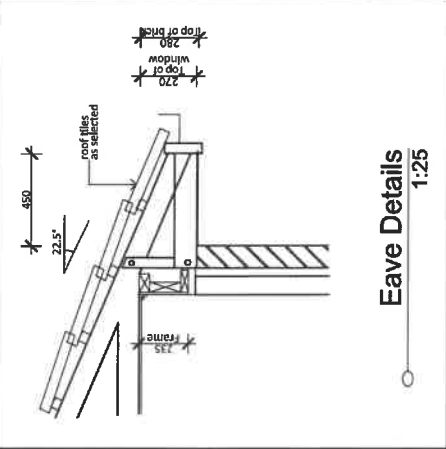

Eave Details
1:25

R.C. Workfield, Stab & Frutkin CO
 Engineers Details

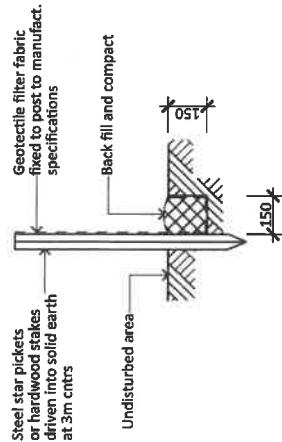

Soil Erosion and Sediment Control Fence
 1. Siltation fencing is to be placed as shown on this site plan so to prevent silt run off to any adjoining property or to the street. This measure is to be in place until the site is stabilized and is to be removed only when the sites surface has been stabilized, i.e. paved, landscaped or turfed.
 2. 40mm crushed rock aggregate is to be placed as an access driveway to the site and must be maintained throughout the course of construction.

Typical Silt Fence
1:20

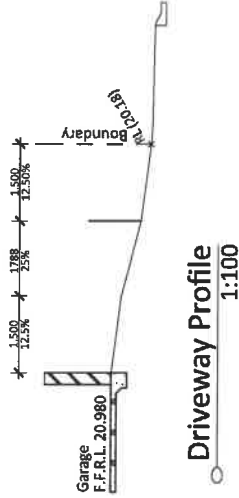

Driveway Profile
1:100

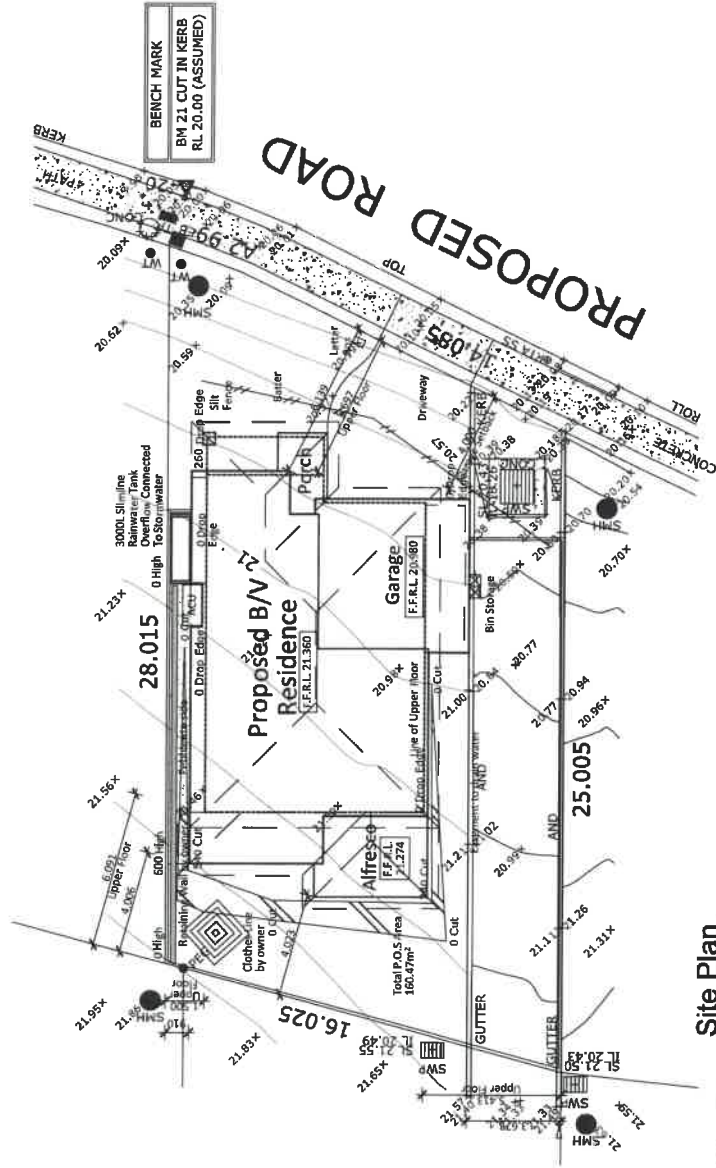

Site Plan
1:200



Lot 20
411,90m²
DP: UNREG

Landscaping Area:
49.50% (203.90m²)

Notes:
 1. Levels shown are approx and should be verified
 2. Measured dimensions are to be taken in preference to scaling
 3. All measurements are in mm unless otherwise stated
 4. Window sizes are nominal only. Final window sizes are to be verified on site by builder before commencement of work.
 5. Dimensions are to be verified on site by builder before commencement of work.
 6. All upstairs windows with a sill height less than 1700mm to have a max opening width of 125mm or fitted with a screen with secure fittings to comply with BCA
 7. Final AJ's to engineers specifications
 8. Plus or minus 200mm to floor levels
 9. Steel beam required if any openings have more than 6 courses of brickwork above

Icon Job Number: J/0343

Client Approval:  **ICON HOMES**
 ICONHOMES.COM.AU

Job:
Proposed B/V Residence

LOT: 20 DP: UNREG
Karinya

Drawing:
Site Plan

Scale:
1:200, 1:20
Date:
06-09-18
Drawing No:
18006-10
Sheet:
7/12
Issue:
K
House Design:
Custom

 **Accurate**
design and drafting
Office: 1a/10 Exchange Parade
Narellan NSW 2567
Phone : 0246472552
Email: info@accuratedesign.com.au

Notes:
 1. Levels shown are approx and should be verified on site
 2. All dimensions are to be taken in preference to scaling
 3. All measurements are in mm unless otherwise stated
 4. Window sizes are nominal only. Final window sizes to be verified on site by builder before commencement of work.
 5. All upstairs windows with a sill height less than 1700mm to have a max opening width of 125mm or fitted with a screen with secure fittings to comply with BCA
 6. Final AJ's to engineers specifications
 7. Plus or minus 200mm to floor levels
 8. Steel beam required if any openings have more than 6 courses of brickwork above

Icon Job Number: J/0343

Client Approval: _____ Date: _____



Job: **Proposed B/V Residence**
 LOT: 20 DP: UNREG
 Karinya

Drawing: **Shadow Diagrams 21st June**

Scale: **1:250** Date: **06-09-18**

Drawing No: **18006-10** Sheet: **11/12** Issue: **K**

House Design: Custom

Accurate
 design and drafting
 Office: 1a/10 Exchange Parade
 Narellan NSW 2567
Phone : 0246472552
 Email: info@accuratedesign.com.au

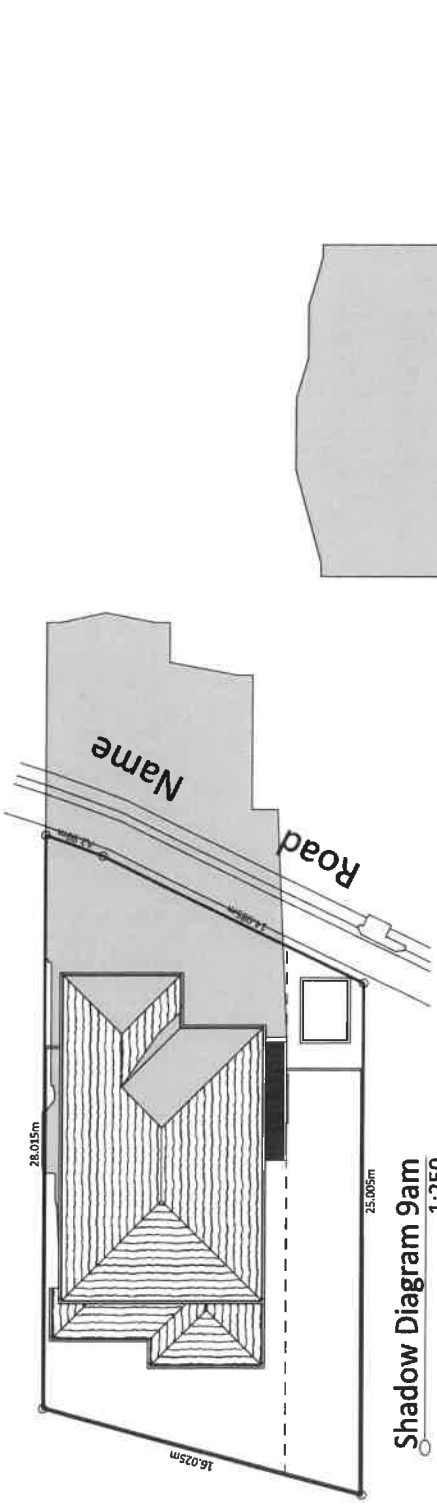

Shadow Diagram 9am
 1:250

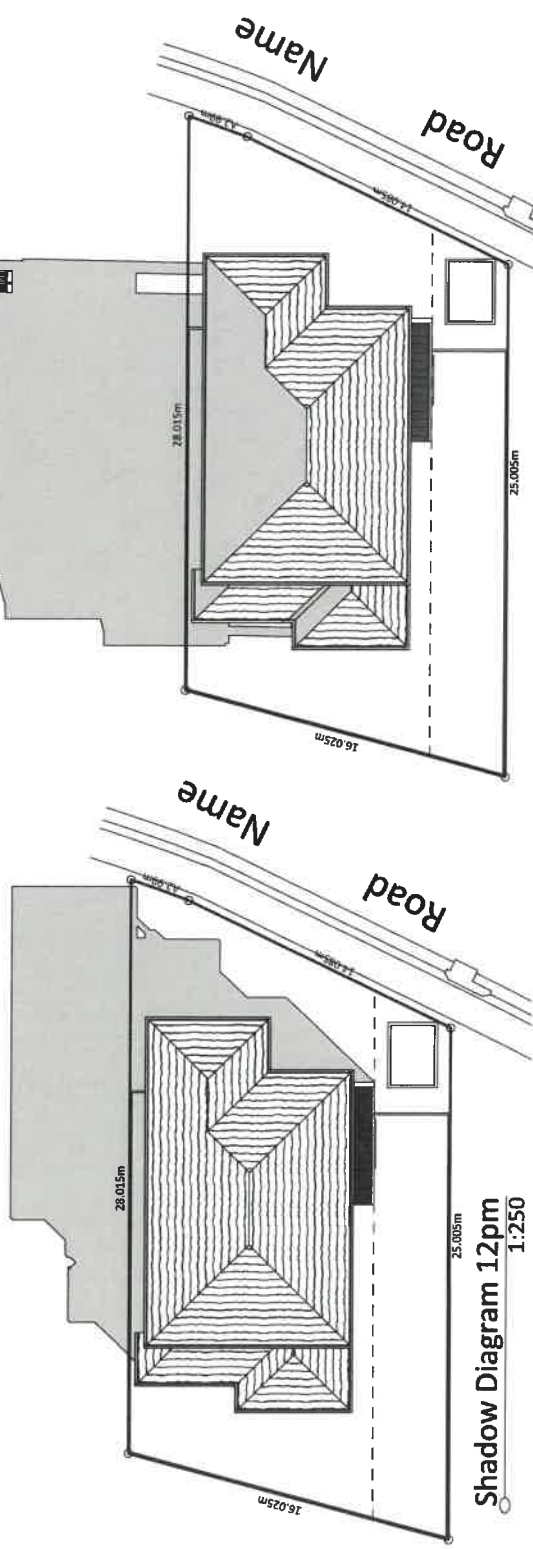

Shadow Diagram 12pm
 1:250

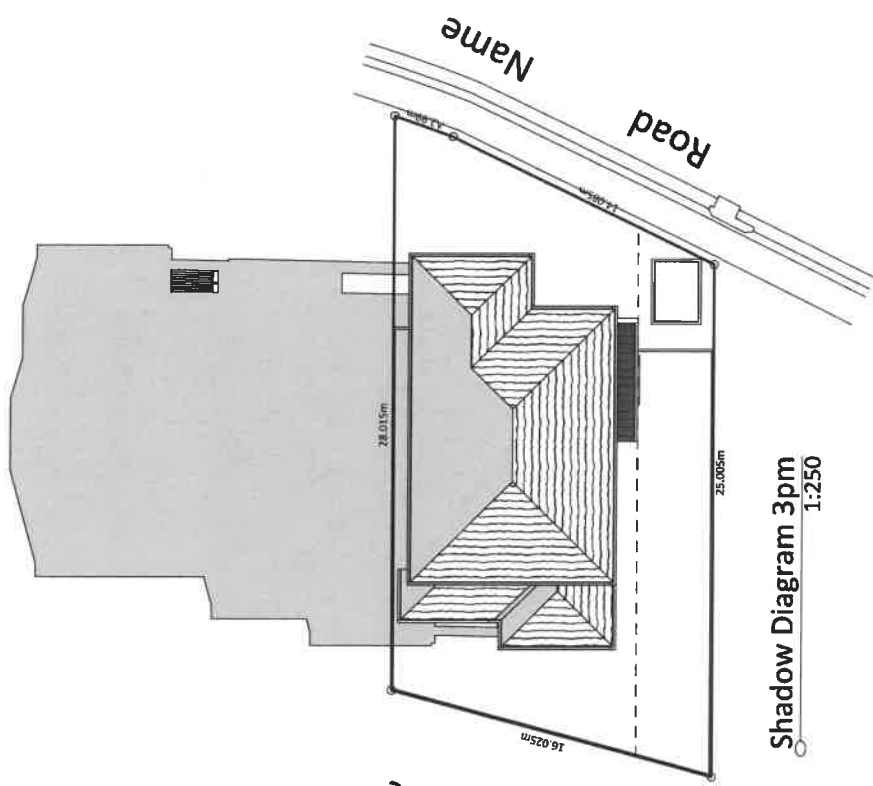

Shadow Diagram 3pm
 1:250



Lot 20
 DP: UNREG