



4 Delmar Parade & 812 Pittwater Road, Dee Why Construction Traffic Management Plan

Prepared for:
Landmark Group

23 July 2024

The Transport Planning Partnership

4 Delmar Parade & 812 Pittwater Road, Dee Why Construction Traffic Management Plan

Client: Landmark Group

Version: V07

Date: 23 July 2024

TTPP Reference: 21205

Quality Record

Version	Date	Prepared by	Reviewed by	Approved by	Signature
V01	25/10/23	Hang Tran, Paul Cai	Oasika Faiz	Ken Hollyoak	-
V02	9/11/23	Hang Tran, Paul Cai	Oasika Faiz	Ken Hollyoak	-
V03	17/11/23	Hang Tran, Paul Cai	Oasika Faiz	Ken Hollyoak	-
V04	22/11/23	Paul Cai	Oasika Faiz	Ken Hollyoak	-
V05	24/11/23	Paul Cai	Oasika Faiz	Ken Hollyoak	-
V06	03/05/2024	Paul Cai	Oasika Faiz	Ken Hollyoak	-
V07	23/07/2024	Paul Cai	Oasika Faiz	Ken Hollyoak	

Table of Contents

1	Introduction	1
1.1	Background.....	1
1.1.1	Modify Consent Condition No. 20	1
1.2	Purpose of this CTMP	2
2	Existing Conditions	3
2.1	Site Description	3
2.2	Surrounding Road Network	4
2.2.1	Pittwater Road	4
2.2.2	Delmar Parade.....	5
2.3	Public Transport Infrastructure.....	5
2.4	Pedestrian and Cycling Infrastructure	7
3	Proposed Construction Activities	8
3.1	Description of Construction Activities	8
3.2	Duration of Works	8
3.3	Construction Work Hours.....	9
3.4	Primary Site Access.....	9
3.5	Secondary Access Option	11
3.6	Construction Vehicle Routes.....	13
3.7	Construction Vehicle Type	15
3.8	Construction Works Zone	15
3.9	Road Occupancy Licence	16
3.10	Materials and Handling Area	17
3.11	Hoarding/Fence	17
4	Construction Traffic Assessment and Implications.....	18
4.1	Construction Traffic Generation	18
4.2	Construction Staff	19
4.3	Construction Worker Parking.....	19
4.4	Pedestrian and Cyclist Access.....	20
4.5	Public Transport Facilities	20
4.6	Emergency Vehicle Access	20
4.7	Adjoining Properties and Local Access	20
4.8	Nearby Major Construction Activities	21
5	Construction Traffic Management Measures.....	22

5.1	Traffic Guidance Scheme	22
5.2	Inspection of Traffic Control Measures	22
5.3	Monitoring	22
5.4	Site Inspection and Record Keeping	23
5.5	Vehicle Access	23
5.6	Truck Routes	23
5.7	Heavy Vehicle Loads	24
5.8	Site Induction Training	24
5.9	Liaison with Stakeholders	24
6	Conclusion	25

Tables

Table 2.1: Bus Services	6
Table 3.1: Construction Staging and Duration	8
Table 3.2: Largest Designed Construction Vehicles.....	15
Table 4.1: Cumulative Construction Traffic Generation.....	18
Table 4.2: Construction Staff Numbers	19

Figures

Figure 2.1: Subject Site and the Surrounding Context	3
Figure 2.2: Master Site Plan.....	4
Figure 2.3: Bus Network Map.....	6
Figure 2.4: Cycling Network	7
Figure 3.1: Existing Access Driveway on Delmar Parade.....	10
Figure 3.2: Secondary Site Access via Stony Range Regional Botanic Garden Car Park	12
Figure 3.3: Vehicle Routes	14
Figure 3.4: Delmar Parade Works Zone Location	16

APPENDICES

- A. TRAFFIC GUIDANCE SCHEME
- B. SWEEP PATH ANALYSIS

- C. CONSTRUCTION SITE PLAN
- D. CTMP APPROVAL (DATED 1 MAY 2024)

1 Introduction

1.1 Background

A Development Application (DA2022/0145) has been approved by Northern Beaches Council (Council) for excavation works and construction of a mixed-use development at 4 Delmar Parade and 812 Pittwater Road, Dee Why.

The approved development included a provision of 219 residential apartments and 817m² of commercial/retail floor area over basement car parking containing 334 car spaces.

The development consent conditions require the preparation of a Traffic Management Plan (Condition No.16), Construction Traffic Management Plan (Condition No. 20) and Demolition Traffic Management Plan (Condition No. 53). The Demolition Traffic Management Plan has been submitted separately to the Council.

The Transport Planning Partnership (TPPP) has prepared this Construction Traffic Management Plan (CTMP) and the associated Traffic Guidance Schemes (Appendix A), on behalf of Landmark Group to address the above consent conditions.

The report has been prepared and checked by engineers who hold the SafeWork NSW Work Health & Safety – Traffic Control Work (PWZ) Training Card, as follows:

- Paul Cai – Card No. TCT0056802

1.1.1 Modify Consent Condition No. 20

It is noted that a Section 4.55 modification (Mod2024/0083) was approved by Council on 26 June 2024, which includes modification of Consent Condition No. 20 of DA2022/0145.

The modified Condition No.20 Construction Traffic Management Plan removes the following truck movement restriction during the major commuter peak times:

*Due to heavy traffic congestion throughout the town centre, truck movements will be restricted during the major commuter peak times being **8.00 am – 9.30 am** and **4.30 pm – 6.00 pm**. Truck movements must be agreed with Council's Traffic Engineer prior to submission of the CTMP.*

Notwithstanding that, the modified Condition No.20 requires that:

No access to the site through the Stony Range car park area is permitted on Tuesdays between 7am and 1pm. Truck movements must be agreed with Council's Traffic Engineer prior to submission of the CTMP.

This CTMP has been updated to be in accordance with the requirements of the modified Condition No.20.

1.2 Purpose of this CTMP

The purpose of this CTMP is to describe how vehicular, cyclist and pedestrian travel and access will be managed during the proposed construction works. This CTMP provides a structured approach to manage traffic and access during each construction stage to provide a safe road environment, minimise impacts on the surrounding road network, while maintaining access for all road users and the local community.

Specifically, the purpose of this CTMP is to:

- Manage access to/from adjacent properties if necessary.
- Manage construction vehicle activity and general traffic around the work site.
- Restrict construction vehicle movements to designated routes to/from the work site.
- Provide a safe environment for vehicular, pedestrian and cyclist movements at all times during construction.
- Maintain accessibility for the local community and maintain access to/from adjacent properties.
- Minimise the construction impacts on the surrounding road users.
- Provide regular information to road users and local communities regarding any changed traffic conditions.
- Carry out construction activity in accordance with the approved work hours.

2 Existing Conditions

2.1 Site Description

The subject site is located at 4 Delmar Parade, Dee Why which falls within Northern Beaches Municipal Council (Council). The subject site is currently occupied by a commercial development. Access to the existing site is provided via Delmar Parade.

The subject site is zoned as B4 Mixed Use Zone. Land uses in the surrounding area comprise high-density residential and a number of commercial / retail developments.

A locality map of the subject site and the indicative site boundary is shown in Figure 2.1. A master site plan is shown in Figure 2.2.

Figure 2.1: Subject Site and the Surrounding Context

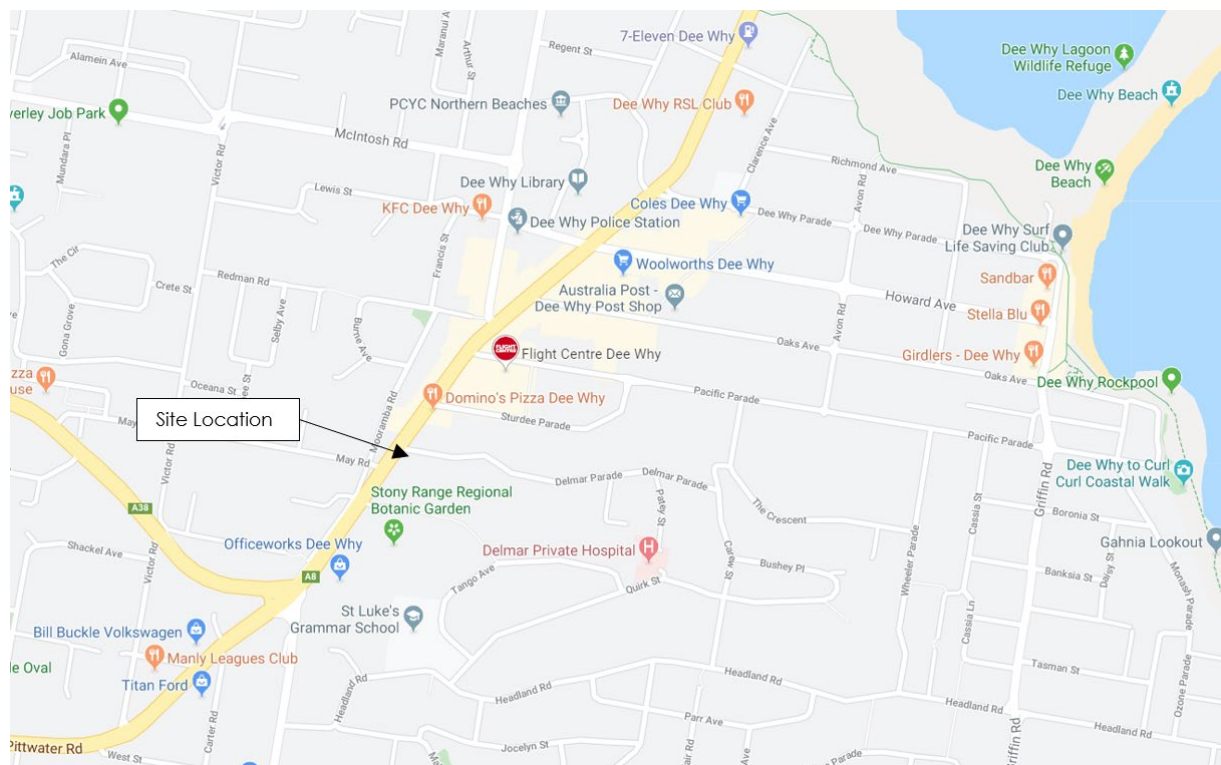

Source: Google Maps

Figure 2.2: Master Site Plan

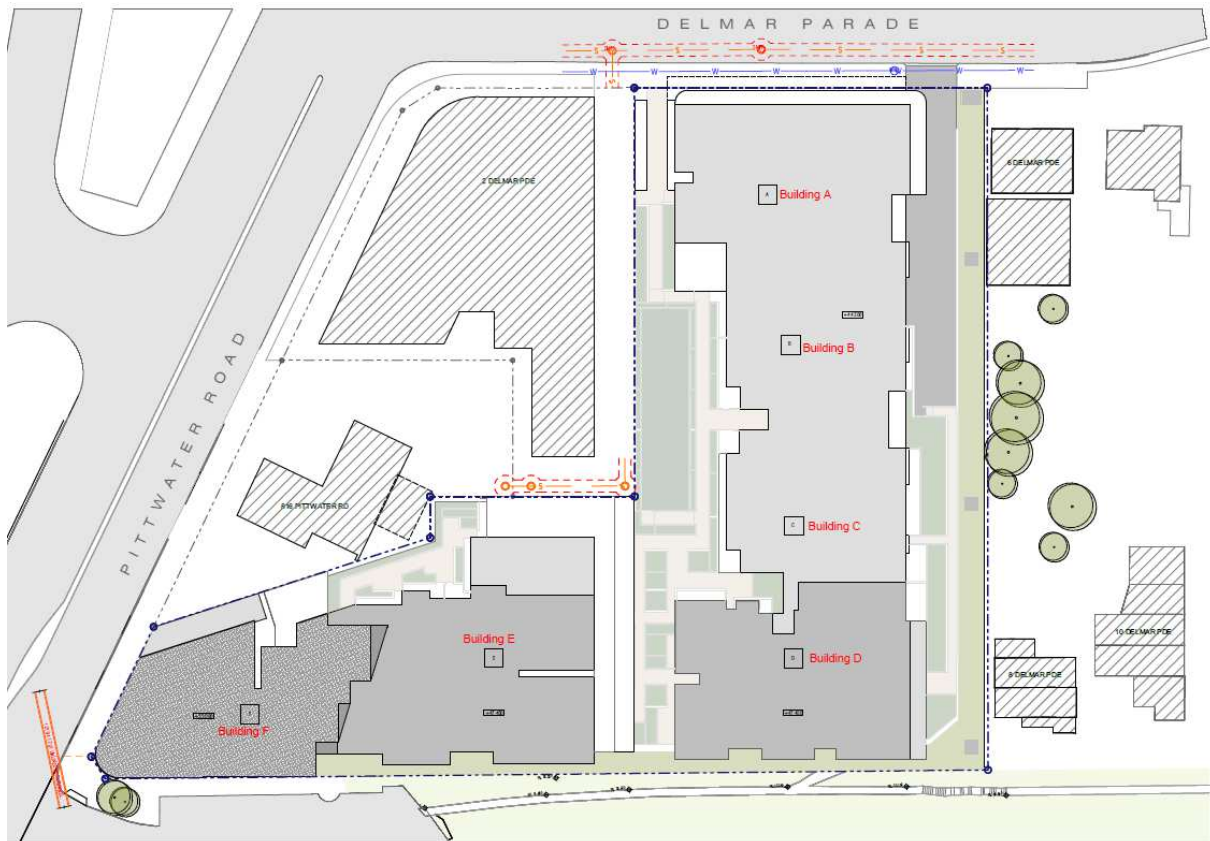

2.2 Surrounding Road Network

2.2.1 Pittwater Road

Pittwater Road is a two-way State Road with a dual carriageway (plus auxiliary turning lanes) and bus lane on both sides of the road.

Pittwater Road is the primary route along the Northern Beaches between Mona Vale and Brookvale and extends in a north-south direction.

On street parking is permitted along Pittwater Road outside of the bus lane operating hours which are:

- 6am – 10am Monday to Friday southbound
- 3pm – 7pm Monday to Friday northbound.

The posted speed limit along Pittwater Road is 60km/hr in the vicinity of the site.

Outside of the bus lane operating hours, 1-hour (1P 10AM-6PM Mon-Fri and 8:30AM-12:30PM Sat) parking restrictions apply on Pittwater Road, which must always be adhered to by staff and any contractors.

2.2.2 Delmar Parade

Delmar Parade is a local road and is aligned in east-west direction along the northern boundary of the site. It is a two-way, two-lane road, on an approximately 12m wide carriageway within a 18m road reserve. Kerbside parking is permitted on both sides and is typically time restricted to two hours. It is sign posted with a 50km/h speed limit.

2-hour (2P 8:30AM-6PM Mon-Fri and 8:30AM-12:30PM Sat) parking restrictions apply on Delmar Parade, which must always be adhered to by staff and any contractors.

A median strip has been installed on Delmar Parade in front of No. 2 Delmar Parade.

2.3 Public Transport Infrastructure

A number of bus services are available in the vicinity of the site. The nearest bus stops are located 300m to the north along Pittwater Road and within 350m from the site on Sturdee Parade.

Bus services, including express services, operate from these stops and provide connections to all destinations north and south of Dee Why between Palm Beach and Manly and the Sydney CBD. Services typically operate at 15 to 30-minute intervals during the peak.

In addition to this, the B-Line services the bus stop located 600m north of the site on both sides of Pittwater Road. The B-Line is a frequent express service that provides connections between Mona Vale and Wynyard and operates between 4:30am until 12:30am. Service frequency on the B-line is typically two to 10 minutes.

The bus network surrounding the site is shown in Figure 2.3, with a summary of relevant routes provided in Figure 2.3.

Figure 2.3: Bus Network Map

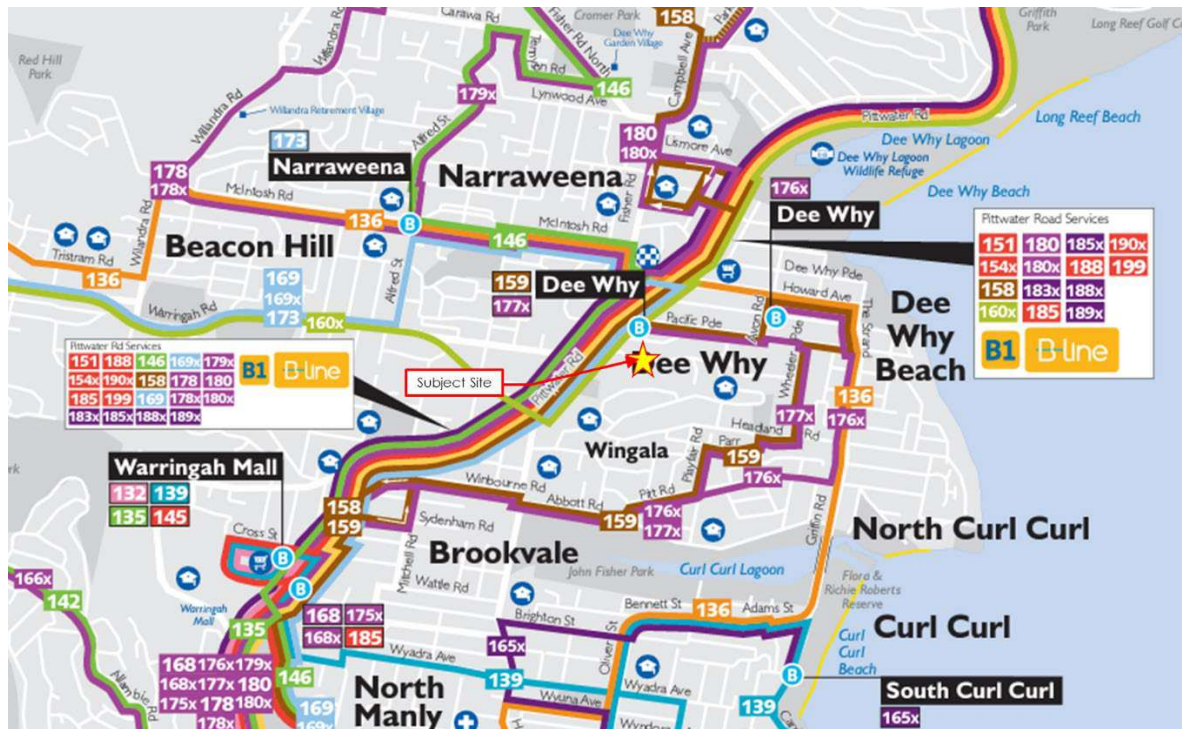

Source: transportnsw.info, accessed 25/09/2023

Table 2.1: Bus Services

Route	Route Description	Site Proximity	Frequency (peak)	Frequency (off peak)
178	Cromer Heights to Warringah Mall	300m	Every 20 mins	Every 30 mins
179	Wheeler Heights to Warringah Mall		Every 20-30 mins	Every 30 mins
180	Collaroy Plateau to Warringah Mall		Every 20 mins	Every 30 mins
199	Palm Beach to Manly		Every 10 mins	Every 10-15 mins
177	Dee Why to Warringah Mall	350m	Every 1 hour	No services during off-peak
177X	Dee Why to City Wynyard (Express service)		Every 10 mins	No services during off-peak
B1	B-Line Mona Vale to City Wynyard	600m	Every 3-5 mins	Every 5-15 mins
154X	Dee Why to Milson Point		Every 5-10 mins	No services during off-peak
158	Cromer to Manly		1 service (PM) only	1 service (PM) only
160X	Dee Why to Chatswood (via French Forest)		Every 10 mins	Every 10 mins
180X	Collaroy Plateau to City Wynyard		Every 10-12 mins	No services during off-peak
181X	Narrabeen to City Wynyard		Every 10-12 mins	No services during off-peak

Source: Transportnsw.info, accessed 25/09/23

2.4 Pedestrian and Cycling Infrastructure

Pedestrian footpaths are generally provided on all surrounding streets to the subject site.

Formal pedestrian crossings are provided on Pittwater Road at its intersection with Sturdee Parade, approximately 100m north of the site.

The path fronting the subject site, along Pittwater Road is a Shared Path. The cycle routes in the vicinity of the site are illustrated in the Transport for New South Wales Cycleway Finder as shown in Figure 2.4.

Figure 2.4: Cycling Network

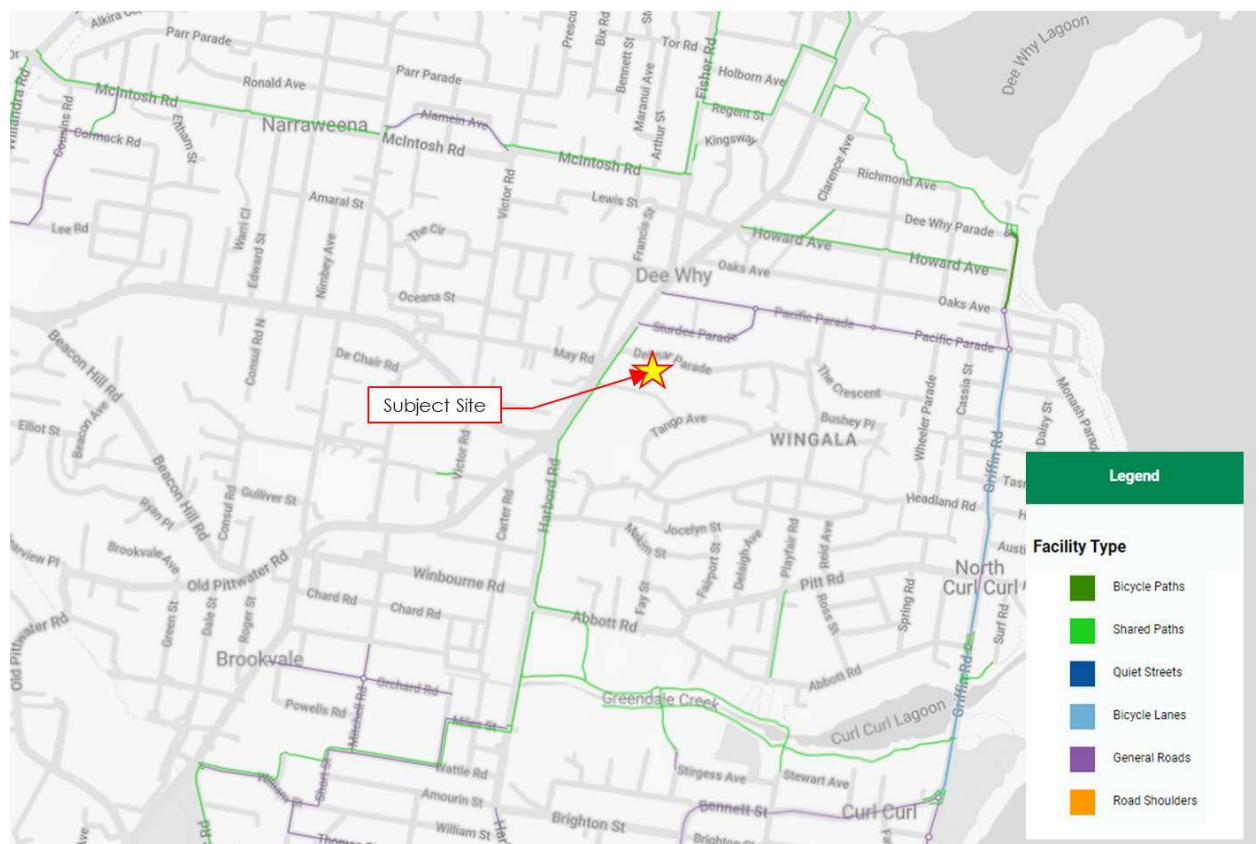

Source: Transport for New South Wales Cycleway Finder (last viewed 25/09/2023)

3 Proposed Construction Activities

3.1 Description of Construction Activities

After the site has been established and demolished (a separate Demolition Traffic Management Plan will be submitted to the Council), the construction works will commence. The proposed construction activities will include the following key stages:

- Stage 1 – Excavation / Piling
 - Excavation over two basement levels
 - Shoring wall installation
- Stage 2 – Construction and Structural Works
 - Construction of 2 blocks with basement levels.
- Stage 3 – Fit-out and Finishes
 - Landscaping and fitting out works.
 - Public domain works.

The extent of the work site will be wholly contained within the site boundary, except the public domain works which will be subject to separate approvals from Council.

3.2 Duration of Works

The indicative construction staging, and estimated duration of each construction stage is summarised in Table 3.1. It is anticipated that some construction stages may be undertaken concurrently.

Table 3.1: Construction Staging and Duration

Construction Stage	Approximate Duration (site access on Delmar Parade only)	Approximate Duration (site access on Delmar Parade and Stony Range Car Park)
Stage 1 – Excavation / Piling	6-8 months	6-8 months
Stage 2 – Construction and Structural Works	12 months	6 months
Stage 3 – Fit-out and Finishes	12 months	8 months
Total	30-32 months	20-22 months

3.3 Construction Work Hours

Construction works will be carried out in accordance with the approved work hours specific the conditions of consent (DA2022/0145) for the development.

Consent Condition #5 (a) specifies the following construction work hours:

(a) Unless authorised by Council:

Building construction and delivery of material hours are restricted to:

- 7.00 am to 5.00 pm inclusive Monday to Friday,**
- 8.00 am to 1.00 pm inclusive on Saturday**
- No work on Sundays and Public Holidays**

Demolition and excavation works are restricted to:

- 8.00 am to 5.00 pm Monday to Friday only.**

(Excavation work includes the use of any excavation machinery and the use of jackhammers, rock breakers, excavators, loaders and the like, regardless of whether the activities disturb or alter the natural state of the existing ground stratum or are breaking up/removing materials from the site).

Modify Consent Condition No. 20 also specifies the following requirement:

No access to the site through the Stony Range car park area is permitted on Tuesdays between 7am and 1pm. Truck movements must be agreed with Council's Traffic Engineer prior to submission of the CTMP.

3.4 Primary Site Access

The subject site has two existing driveways on Delmar Parade as shown in Figure 3.1. it is proposed that primary vehicle access to the construction site will be provided via these two existing driveways.

Figure 3.1: Existing Access Driveway on Delmar Parade



Source: NearMap

It is noted that the majority of construction vehicles would travel from the south and turn right from Pittwater Road onto Delmar Parade to access the site. However, right turn movement is restricted from Pittwater Road to Delmar Parade between 6am and 10am, Monday to Friday. Construction trucks would need to be detoured via St David Avenue and Fisher Road to travel south on Pittwater Road and turn left onto Delmar Parade to access the site during those times.

It is expected that there will be a small number of trucks travelling to the site from the north, which will turn left from Pittwater Road onto Delmar Parade to access the site.

Notwithstanding the above, swept paths of a 19m truck and dog and a HRV turning left from Pittwater Road southbound onto Delmar Parade have been undertaken by TTPP. The swept paths indicate that the vehicles would go over the centre line / median strip on Delmar Parade and encroach the westbound traffic on Delmar Parade.

Therefore, it is required to remove part of the median strip on Delmar Parade to accommodate the left turn movement from Pittwater Road onto Delmar Parade for a truck and dog trailer / HRV. The swept path analysis and associated length of the median strip that needs to be removed are presented in Appendix B.

Furthermore, a traffic controller will be required to temporarily hold westbound traffic on Delmar Parade approaching the intersection, when a large truck is turning left from Pittwater

Road onto Delmar Parade. The proposed traffic control measures are included in the TGS in Appendix A.

Construction trucks will then exit the site in a forward direction, when there is a suitable gap in traffic.

3.5 Secondary Access Option

The site access off Delmar Parade would have the following limitations and impacts:

- Trucks are restricted to left-turn only from Pittwater Road onto Delmar Parade between 6am-10am weekdays. Large trucks (such as truck and dog tailers and HRVs) are required to encroach the existing concrete median island on Delmar Parade to accommodate the left turn manoeuvre. Therefore, the existing concrete island would need to be temporarily removed.
- Trucks turning left from Pittwater Road onto Delmar Parade would also encroach the westbound lane on Delmar Parade. Therefore, traffic controllers are required to temporarily hold westbound traffic on Delmar Parade during truck entry from the north.
- Delmar Parade only fronts a small portion of the site, that is, the eastern buildings (Building A & B), as shown in Figure 2.2. Given the extensive length of site, access to the western buildings (Building D, E and F) and Building C cannot be obtained from the Delmar Parade frontage during the construction stage.
- The subject site has a 18m long frontage to Pittwater Road in the west. However, given Pittwater Road is a busy classified road and the site frontage is located within a "No Parking" zone, vehicular access or kerbside works zone on Pittwater Road would not be permitted. Therefore, access options for the site are limited.

To mitigate some of the above constraints and limitations, it is proposed to provide a secondary site access from the southern side of the site, via the Stony Range Regional Botanic Garden Car Park (Stony Range Car Park).

The existing car park is a Council car park providing parking for visitors of the Stony Range Regional Botanic Garden. Vehicle access to the car park is provided off Pittwater Road, and three hours (3P) parking restriction from Monday to Friday applies to car park.

It is proposed to occupy the eastern side of the car park as a construction zone to accommodate truck access to the site during excavation stage, and as a temporary works zone for loading/unloading construction materials during construction stage. The proposed construction zone and secondary site access via the Stony Range Car Park is shown in Figure 3.2. The proposed use of the Stony Range Car Park would require the temporary removal of 20 car spaces and retention of 6 car spaces for visitors. Additional 7 car parking spaces in the south of the proposed construction zone will be made available for public parking on Saturday after 1PM and Sunday.

A 1.2m wide pedestrian path will be provided around the construction zone to connect with the existing pedestrian path between the car park and Tango Avenue, as shown in Figure 3.2. The pedestrian path will be protected by barriers and fence and the construction zone will also be enclosed by fence to prevent public from accessing the construction area. Barriers/fence along the southern side of the proposed construction zone will be removed on Saturday after the construction work hours and on Sunday to provide additional 7 car parking spaces to the public.

A Traffic Guidance Scheme has been prepared for the proposed construction zone within the Stony Range Car Park, as shown in Appendix A.

Figure 3.2: Secondary Site Access via Stony Range Regional Botanic Garden Car Park

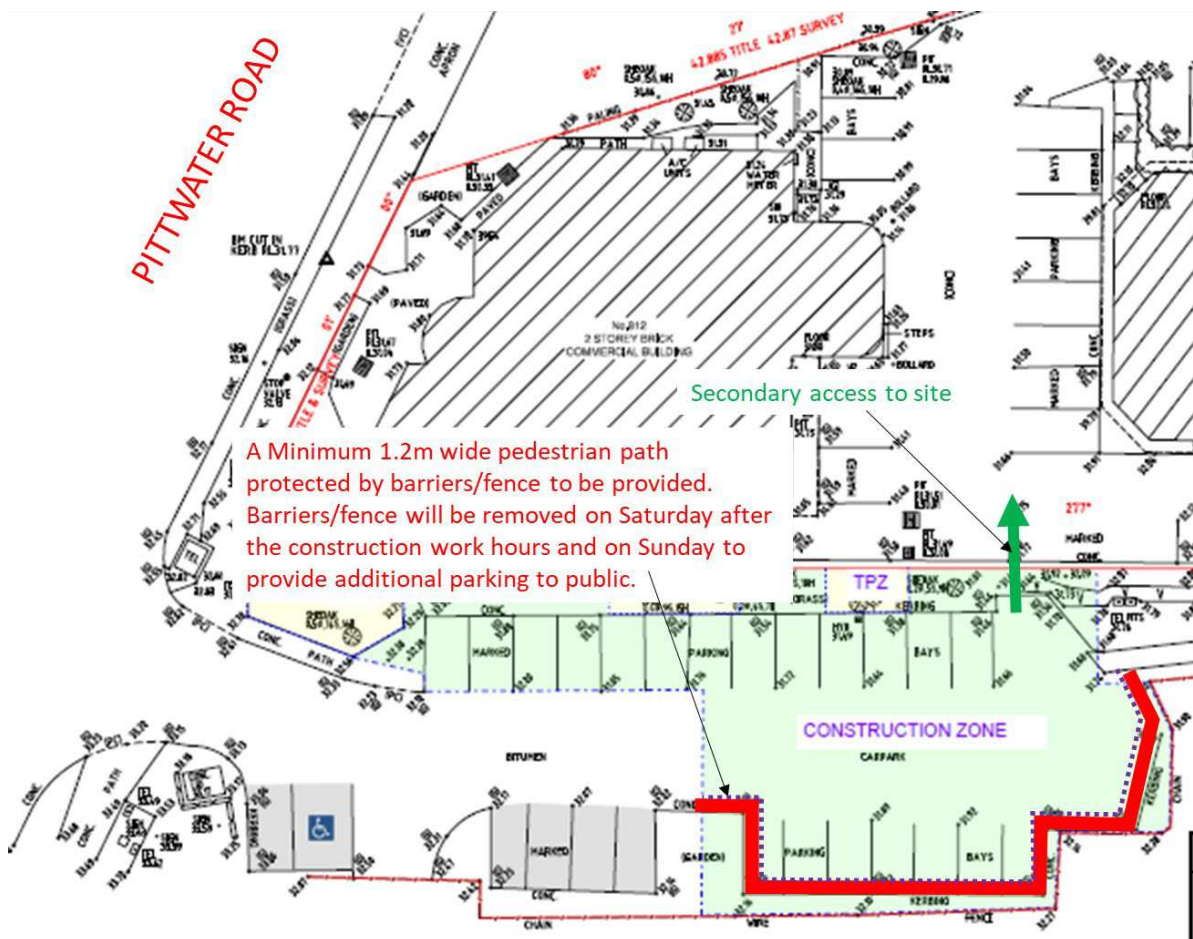

By allowing a secondary site access at the rear of the site, it is possible to provide a through site link that allows trucks to enter the site via the car park off Pittwater Road and exit to Delmar Parade during excavation stage, when there would be a notably generation of 19m truck and dogs. This one-way circulation through the site would immensely improve the access arrangements. Notably, swept path analysis indicates that by providing ingress from the car park and egress to Delmar Parade, there would be no more need for removal of the existing median strip on Delmar Parade or stopping westbound traffic on Delmar Parade,

which is impacted by the left-turn movement from Pittwater Road onto Delmar Parade. Swept path analysis showing a truck and dog trailer entering the site via the car park and exiting onto Delmar Parade is presented in Appendix B.

It is anticipated that during the excavation stage the construction site will generate about 40 vehicles per day, which is equivalent to 80 two-way vehicle movements. By having a secondary site access, it would be able to distribute the traffic movements over two access points. The truck movements on Delmar Parade could be reduced to 40 egress movements per day with the 40 ingress movements through the Stony Range Car Park. Therefore, the impacts on the Delmar Parade traffic would be reduced.

During construction of the structures, the constructability of the site would be improved by having a secondary works zone within the Stony Range Car Park along the southern boundary of the site. The southern tower crane can unload materials directly from trucks parked adjacent to the southern boundary of the site to Building D, E and F, thus the loading operation would be more efficient. As a result, it is expected that the duration of the construction works would reduce from 30-32 months down to 20-22 months with the secondary access on the Stony Range Car Park. Therefore, the proposal of using the Stony Range Car Park as a secondary site access is expected to have great benefits for Council and the surrounding areas in reducing the impacts during the excavation and construction works.

The largest designed vehicle that will access the secondary works zone within the car park is a standard 8.8m long Medium Rigid Vehicle. Swept path showing a MRV accessing the works zone is presented in Appendix B.

Notwithstanding the above, it is noted that the secondary access via the Stony Range car park was approved by Council on 1 May 2024, as shown in the CTMP approval provided in Appendix D.

As per Council's requirements, no access to the site through the Stony Range carpark area is permitted on Tuesdays between 7am and 1pm. No permits will be issued for access from the Stony Range carpark to the subject site after 1pm on Saturdays.

3.6 Construction Vehicle Routes

Construction vehicles will have origins and destinations throughout Sydney. Dedicated construction vehicle routes have been developed to provide the shortest distances to/from the arterial road network, whilst minimising the impact of construction traffic on streets within the immediate vicinity of the site.

All truck drivers will be advised of the designated truck routes to/from the site and be required to adhere to the nominated routes.

It is anticipated that the majority of construction vehicles would travel to/from the south and would make use of the Sydney Harbour Bridge/ Cahill Expressway, Military Road, Spit Road, Manly Road, Burnt Bridge Creek Deviation, Condamine Street and Pittwater Road to access the site. Vehicles travelling from the north would make use of Pittwater Road and Warringah Road, respectively.

Right turn movement is restricted from Pittwater Road to Delmar Parade between 6am and 10am, Monday to Friday. Therefore, drivers arriving from the south are to detour via St David Avenue and Fisher Road (turning right from Fisher Road to travel southbound along Pittwater Road) during those periods.

Construction vehicle movement routes are shown in Figure 3.3.

It is to be noted that no access to the site through the Stony Range carpark area is permitted on Tuesdays between 7am and 1pm.

Construction vehicles are to radio or call on approach to ensure adequate access to the site and/or works zone is made available.

Figure 3.3: Vehicle Routes



3.7 Construction Vehicle Type

During the excavation stage, it is anticipated that the largest construction vehicle will be a 19m long truck and dog trailer. Other rigid trucks, including medium rigid vehicle (MRV) and small rigid vehicle (SRV) would also visit the site occasionally.

During the construction and Fit-out stages, it is anticipated that the largest construction vehicle will be a heavy rigid vehicle (HRV). Other types of trucks, including MRV, SRV and concrete trucks would also be used.

A summary of the largest construction vehicles expected during each construction stage of the works is provided in Table 3.2.

Table 3.2: Largest Designed Construction Vehicles

Construction Stage	Largest Construction Vehicle
1. Excavation	19.0m Truck and Dog
2. Structure	12.5m Heavy Rigid Vehicle
3. Facade and Internal Finishes	12.5m Heavy Rigid Vehicle

3.8 Construction Works Zone

During construction Excavation Stage:

No work zones will be required. All deliveries and materials handling to be happen within the subject site only.

During Construction Structural Works and Fit-outs Stages:

- Primary Works Zone: a 15m works zone is proposed along Delmar Parade in front of the site during stage 2 and 3. The proposed works zone would occupy 2-3 on-street spaces which are currently time restricted as 2-hour parking.
- Secondary Works Zone: a secondary works zone is proposed within the Stony Range Car Park along the southern frontage of the site. This works zone would allow trucks to park adjacent to the south and east part of the site for unloading and loading construction materials for Building D, E and F.
- The proposed primary and secondary works zones are shown in in Figure 3.4.

Figure 3.4: Delmar Parade Works Zone Location

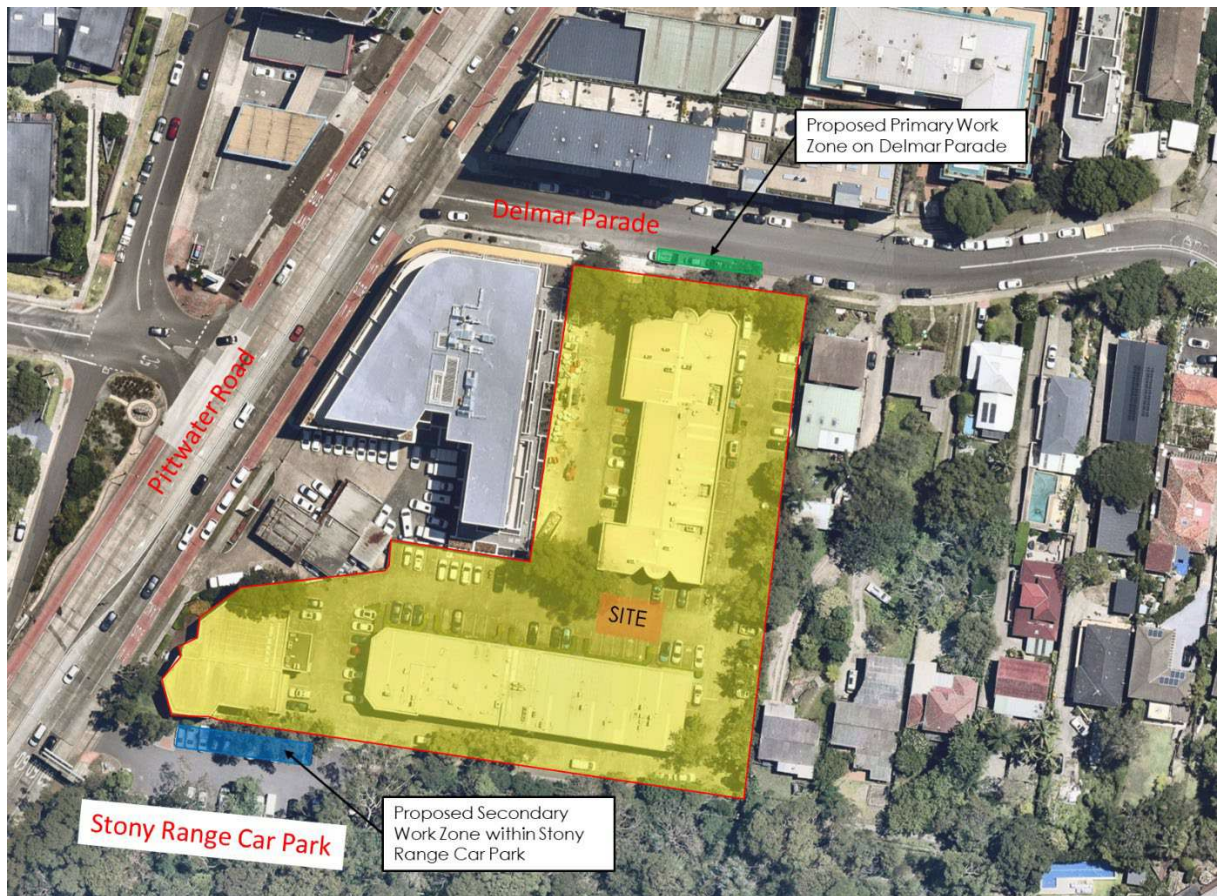

Base Map Source: Nearmap, photograph dated 03/10/23

Loading activities will be undertaken both on-site and in the works zone during the construction (stage 2) and Fit-out (stage 3) stages.

A swept path analysis has been undertaken demonstrating a HRV accessing the primary works zone on Delmar Parade and the secondary works zone within the Stony Range Car Park, as presented in Appendix B.

A separate application will be submitted to the Council to obtain a works zone permit when a works zone is required.

3.9 Road Occupancy Licence

A Road Occupancy Licence (ROL) is required from Transport for NSW's Traffic Management Centre (TMC), for any road works required on State Roads or within 100m of traffic signals. In this case, an ROL is not expected to be required.

If roadworks on a State Road or within 100m of traffic signals is required, a separate application will be made to TMC and Council. The Contractor would be responsible for obtaining all relevant ROLs as required.

3.10 Materials and Handling Area

All materials handling and plant equipment, including waste storage, are expected to be wholly stored on-site within the works site. It is not expected that any public road will be required for such purposes.

However, if temporary use of any public road is required for temporary storage purposes or the like, prior consultation with Council will be undertaken. All relevant permit approvals will also be obtained prior to the commencement of such activities.

3.11 Hoarding/Fence

Appropriate hoarding/fence will be installed along the site boundary to prevent public from accessing the construction site and for pedestrian protection.

All relevant permit approvals will be obtained prior to the installation of any hoarding / fence measures. This would be a separate application to this CTPMP.

4 Construction Traffic Assessment and Implications

4.1 Construction Traffic Generation

It is anticipated that the construction activities would generate the following number of construction vehicles:

- Stage 1 - Excavation / Piling: up to 40 vehicles per day
- Stage 2 - Structural and Construction Works: 10 – 15 vehicles per day
- Stage 3 – Fit-out and Finishes: 10 – 15 vehicles per day.

The estimated total construction vehicle movements and the commuter peak time truck movements associated with each stage of construction are summarised in Table 4.1.

Table 4.1: Cumulative Construction Traffic Generation

Construction Activities	Number of Vehicles per Day	Average Two-Way Vehicle Movements per Day	Two-Way Vehicle Movements per Hour
Stage 1 – Excavation / Piling	Up to 40 vehicles	80 vehicle movements	Up to 13 vehicle movements
Stage 2 – Structural and Construction Works	10-15 vehicles	20-30 vehicle movements	Up to 5 vehicle movements
Stage 3 – Fit-outs and Finishes	10-15 vehicles	20-30 vehicle movements	Up to 5 vehicle movements

Note: 2 vehicle movements = 1 truck entering and exiting the site.

Based on Table 4.1, the average daily construction traffic volume would be no greater than 80 vehicle movements per day, or up to 13 vehicle movements per hour during excavation stage.

The proposed restricted truck movements during the commuter peak times are subject to Council's approval.

It is expected that majority of the construction trade-people would travel to and leave the construction site by public transport when there is limited on-site parking available for construction workers. It is expected that there will be up to 150 workers on site during the building fit-out and finishing stage. Assuming 60% of the workers will travel by public transport and 25% of the workers who travel by car will carpool. It is anticipated that the construction workers will generate about 23 vehicle trips in the AM and PM respectively during stage 4.

Notwithstanding the above, peak worker vehicle trips will typically occur at the start of the day in the morning when majority of the construction workforce arrive on site before 7AM. This is earlier than the commuter morning peak hour and the school peak in the morning. It is also expected that majority of the trade-person will generally leave the site around 4PM despite

that the latest work hour is 5PM from Monday to Friday, except some works such as concrete pour that requires majority of workers to stay until the last minute occasionally. Therefore, the typical afternoon peak of construction worker trips will occur around 4PM, which is after the school peak but before the commuter peak.

Therefore, the construction worker traffic is not expected to have adverse impacts on the surrounding road network.

4.2 Construction Staff

The number of construction workers is expected to vary throughout the various stages of works. The expected number of workers on-site for each stage is detailed in Table 4.2.

Table 4.2: Construction Staff Numbers

Stage	Number of Workers per Day
Stage 1 – Excavation / Piling	10-25 workers
Stage 2 – Structural and Construction Works	50-80 workers
Stage 3 – Fit-outs and Finishes	100-150 workers

4.3 Construction Worker Parking

On-site construction worker parking is not proposed due to the footprint size of the proposed development leaving no available space on site. All construction staff would be advised to utilise public transport to travel to / from the site when possible.

This will be incorporated in the workers induction program to encourage workers to use public transport and/or carpool to travel to/from the site, thus, to minimise parking impact on surrounding streets. The closest bus stops are located on Pittwater Road, which is approximately 400m (or 6min) walking distance from the site.

The following measures would be implemented to encourage staff to utilise public transport:

- provide an on-site tool drop-off and storage facility to allow tradespeople to drop off and store their specific machinery for the project.
- inform staff during the induction and regular management meetings that no on-site car parking will be available and the restricted parking conditions surrounding the site.
- instruct staff to use public transport to access the site during the induction and regular management meetings.
- display public transport timetable information at key locations within the work site and ensure that it is easily accessible by staff.

Notwithstanding the above, it is noted that once the basement car parking level and associated vehicle access has been constructed, there will be an opportunity to utilise the basements for on-site construction worker parking.

4.4 Pedestrian and Cyclist Access

Pedestrian and cycle access along the public roads will be maintained as per existing conditions during the project.

As all construction activities will be contained wholly within the site, away from any pedestrian and cycling infrastructure and any road reserves, no adverse impacts are expected on pedestrians and cyclists' activities.

Pedestrian safety along the footpaths fronting the site access is to be managed by the presence of traffic controllers, who would temporarily hold pedestrians while a vehicle enters the site. Pedestrians are expected to be held for a short period. However, pedestrians must not be stopped, detoured or held for a long period of time in anticipation of vehicles entering/exiting.

Appropriate hoarding/fence will be installed along the site boundary to prevent public from accessing the construction site and for pedestrian protection.

4.5 Public Transport Facilities

The proposed construction activities would not impact any existing public transport services.

4.6 Emergency Vehicle Access

No special provisions for emergency service vehicles are required as part of the proposed construction works. Emergency vehicle access shall be maintained as per existing conditions.

Access to the subject site and the neighbouring sites by emergency vehicles would not be affected by the construction works.

4.7 Adjoining Properties and Local Access

Access to the neighbouring properties will be maintained as per existing conditions during the project. No major impacts are expected on the local access from the proposed construction works.

4.8 Nearby Major Construction Activities

TTPP has not been made aware of any other major construction activities that currently are being undertaken or will be undertaken within a 250m radius of the subject site during the construction works of the site.

5 Construction Traffic Management Measures

5.1 Traffic Guidance Scheme

Site-specific Traffic Guidance Schemes (TGSs, previously referred as Traffic Control Plans) have been prepared and designed in accordance with TfNSW Traffic Control at Works Sites manual. The TGSs are provided in Appendix A.

Dedicated site personnel would be assigned on-site to manage and assist construction vehicle movements associated with the proposed development works.

Advisory road signage would be installed along surrounding streets to warn drivers approaching the site location of construction vehicles entering and exiting the site.

All advisory signage would be installed in accordance with AS 1742.3 *Manual of Uniform Traffic Control Devices – Traffic Control Devices for Works on Roads* and the TfNSW *Traffic Control at Worksites Manual*. Signage would be installed and maintained throughout the construction period, as required.

5.2 Inspection of Traffic Control Measures

Temporary traffic controls will be regularly inspected by the contractor to identify potential safety hazards to enable implementation of corrective solutions.

Daily inspections and maintenance of controls will be undertaken by the contractor and maintenance will be recorded on days that truck movements are scheduled to occur.

The site supervisor will check all relevant traffic control management measures on-site prior to commencement of works each day on days that truck movements are scheduled to occur.

5.3 Monitoring

Monitoring of this CTMP will be undertaken by the contractor during weekly inspections of construction activities to monitor conformance with the requirements of Council and this plan. Weekly inspections will focus on the following key issues:

- Safe movement of traffic
- Visibility of signage and barriers
- Safe work and driving environment
- Safety of pedestrians, cyclists and properties around the work site

Traffic will be monitored on the road network including traffic entering and exiting the work site and at key areas impacted by the works.

5.4 Site Inspection and Record Keeping

The construction operation would be monitored to ensure that it proceeds as set out in the Contractor's Construction Management Plan (CMP) provided by the Head Contractor. A daily inspection before the start of the construction activity would be carried out to ensure that conditions accord with those stipulated in the plan and prevent any potential hazards. Any issues and identified risks would be recorded and dealt with, as they occur.

5.5 Vehicle Access

All construction vehicles will enter and exit the site in a forward direction and focus on the following key issues:

- Construction vehicles would be required to radio the site office on approach to the site to ensure access to the site is available.
- General vehicle access along all public roads and the private access driveway to the neighbouring properties would be maintained at all times.
- Construction vehicles would enter and exit the site in a forward direction. No reversing movements in/out of the site would be permitted.
- Construction vehicles would not queue on public roads on approach to the site.
- Any materials loaded on the construction vehicle would be fully covered to avoid spillage. Similarly, vehicle loads would be covered when hauling to/ from the site.
- Any material spill onto the road would be rectified by qualified site personnel using appropriate equipment, subject to suitable WHS provision.

5.6 Truck Routes

The following protocols must be in place to minimise the impacts associated with the nominated construction vehicle routes:

- Site induction shall include procedures for accessing the site.
- Drivers shall adhere to the designated truck routes shown in Section 3.6.
- Drivers shall be aware of pedestrians and cyclists in the vicinity of the site.
- Drivers shall be aware of existing sign posted speed limits.
- Site induction shall promote road safety and obeying the NSW road rules at all times.
- Truck drivers must not drive under the influence of drugs and alcohol.

5.7 Heavy Vehicle Loads

All drivers will be required to adhere to the posted vehicle load limits on all roads and not overload vehicles beyond its maximum loading limits and/or relevant approvals.

All trucks entering or leaving the site with loads must have their loads covered and must not track dirt onto any public road. Prior to leaving site covering truck loads is mandatory and when required, tailgates must be swept clean before leaving site.

5.8 Site Induction Training

All construction workers employed at the site by the construction contractor shall be required to undergo a site induction training.

The induction training shall include nominated construction transport routes to and from the proposed work site for site personnel and construction vehicles, along with standard environmental, WH&S, driver protocols and emergency protocols. This training would be the responsibility of the construction contractor.

5.9 Liaison with Stakeholders

A Community Liaison Manager shall be appointed manage all community queries and/or issues relating to the project for actioning, as necessary. Written notification will be provided to likely and potentially affected sensitive receivers prior to commencement of any activities associated with construction. This will include local residents, local businesses and relevant authorities and be provided at least 7 days prior to excavation commencing. The format of notification may include such measures such as email notification or letter box drops.

6 Conclusion

This CTMP has been prepared to document the proposed construction traffic management measures to facilitate the construction works at 4 Delmar Parade and 812 Pittwater Road, Dee Why.

The key findings of the CTMP can be summarised as follows:

- The construction works duration are estimated to be approximately 30-32 months if site access is only provided on Delmar Parade or 20-22 months if site accesses are provided on Delmar Parade and the Stony Range Car Park.
- The construction works will be undertaken in 3 stages, including site excavation / piling, construction and structural works, and fit-out and finish works.
- The construction work hours will be in accordance with the approved hours specified in the consent conditions #5(a) and #20.
- No access to the site through the Stony Range carpark area is permitted on Tuesdays between 7am and 1pm.
- The construction works are anticipated to generate up to 80 heavy vehicle movements per day during the excavation stage or up to 13 heavy vehicle movements per hour during the approved truck movement hours on weekdays. This level of traffic generation is not expected to have adverse impacts on the surrounding road network.
- For excavation stage, it is proposed that loading/unloading of trucks is to occur within the site.
- No on-site parking will be provided for construction workers. It is expected that majority of the construction workers will travel to/from the construction site by public transport.
- No adverse impacts are expected on pedestrian and cyclist movements, general traffic, and public transport services as they will be maintained as per existing conditions for the duration of the project.
- A number of driver protocols would be established as part of the site induction procedure for truck drivers to follow the nominated construction transport route, while maintaining the safety of the surrounding road users and pedestrians.

In conclusion, the proposed CTMP measures would adequately address the potential impacts of the construction works on the surrounding road network and road users. This CTMP fulfils the requirements of the Consent Condition No. 16 of DA2022/0145 and modify Consent Condition No.20 of Mod2024/0083.

Appendix A

Traffic Guidance Scheme

TRAFFIC MANAGEMENT NOTES:

1. NOT ALL DIMENSIONS SHOWN ARE TO SCALE.
2. LOCATION OF SIGNS ARE TO BE CONFIRMED ON-SITE TO ENSURE APPROPRIATE VISIBILITY.
3. ALL SIGNS TO BE MINIMUM SIZE A.
4. ALL SIGNS TO BE CLASS 1 REFLECTIVE OR DIAMOND GRADE.
5. ALL WORKERS WILL BE CONFINED TO THE DEDICATED WORKS AREA SHOWN ON THE PLAN.
6. ALL TRAFFIC CONTROL PLANS ARE TO BE IMPLEMENTED IN ACCORDANCE WITH THE TFNSW "TRAFFIC CONTROL AT WORK SITES" MANUAL, VER6 (2020) AND AUSTRALIAN STANDARDS AS1742.3:2009 MANUAL OF UNIFORM TRAFFIC CONTROL DEVICES, PART 3: TRAFFIC CONTROL DEVICES FOR WORKS ON ROADS.
7. THIS TRAFFIC CONTROL PLAN MUST BE SETUP BY A PERSON HOLDING AN "APPLY TRAFFIC CONTROL PLANS" (YELLOW TICKET) AND THE TFNSW TRAFFIC CONTROL AT WORK SITES CHECKLIST SHALL BE COMPLETED PRIOR TO IMPLEMENTATION.
8. IT IS THE SITE FOREMAN'S RESPONSIBILITY TO ENSURE THE FOLLOWING:
 - THE INTEGRITY OF ALL TRAFFIC CONTROL MEASURES THROUGH TO THE FINAL REMOVAL. THIS INCLUDES DAILY CHECKS OF ALL SIGNS AND DEVICES. THE CORRESPONDING RECORDS OF CHECKS SHALL BE KEPT ON FILE FOR AUDITING PURPOSES.
 - VEHICULAR ACCESS AND SERVICING REQUIREMENTS ARE TO BE MAINTAINED AT ALL TIMES TO ADJACENT PROPERTIES AFFECTED BY TRAFFIC CONTROL MEASURES
 - PEDESTRIAN ACCESS AROUND THE WORK AREA TO BE MAINTAINED AT ALL TIMES.
 - AT ALL TIMES UP-TO-DATE COPY OF "TRAFFIC CONTROL AT WORK SITES" SHOULD BE AVAILABLE FOR REFERENCE AND IMPLEMENTATION AS REQUIRED ON-SITE
 - IF THERE IS NO DESIGNATED SITE FOREMAN, THE RESPONSIBILITY SHALL FALL ON THE CONTRACTOR OF WORKS
9. ALL WORKERS MUST ADHERE TO THE APPLICABLE SAFE WORK DISTANCE AS DESCRIBED IN AS1742.3:2009
10. ALL DISTANCES BETWEEN SIGNS ARE TO BE IN ACCORDANCE WITH THE SECTION 2.5.2 OF AS1742.3:2009. HOWEVER, MODIFICATIONS MADE TO SUIT SITE CONDITIONS.
11. ALL CONSTRUCTION VEHICLE ACTIVITY SHOULD BE MINIMISED, WHERE POSSIBLE, DURING PEAK PERIODS.
12. TRAFFIC CONTROLLER AHEAD (T1-34) AND PREPARE TO STOP (T1-18) SIGNS TO BE COVERED OR REMOVED WHEN TRAFFIC CONTROLLER/S ARE NOT ON SITE.
13. ROAD WORK SIGNS TO BE COVERED OR REMOVED WHEN WORKERS ARE NOT ON SITE.
14. NO TRUCK QUEUING OR PARKING WILL BE PERMITTED IN ANY PUBLIC ROAD OUTSIDE THE PROPOSED WORKS ZONE.
15. VEHICLES ALREADY ON THE ROAD WILL HAVE A RIGHT OF WAY. AS SUCH EVERY VEHICLE LEAVING THE SITE MUST WAIT UNTIL A SUITABLE GAP IN TRAFFIC ALLOWS THEM TO EXIT UNDER THE DIRECTION OF QUALIFIED TRAFFIC AND PEDESTRIAN CONTROLLER.
16. PEDESTRIANS WILL ONLY BE HELD FOR SHORT TIME TO ALLOW TRUCKS TO ENTER AND EXIT FROM THE SITE. PEDESTRIANS HAVE THE RIGHT OF WAY ON THE FOOTPATH AND WILL NOT BE STOPPED IN ANTICIPATION.
17. ADJOINING PROPERTIES AND SIDE ROADS WILL NOT BE AFFECTED BY THE WORKS.

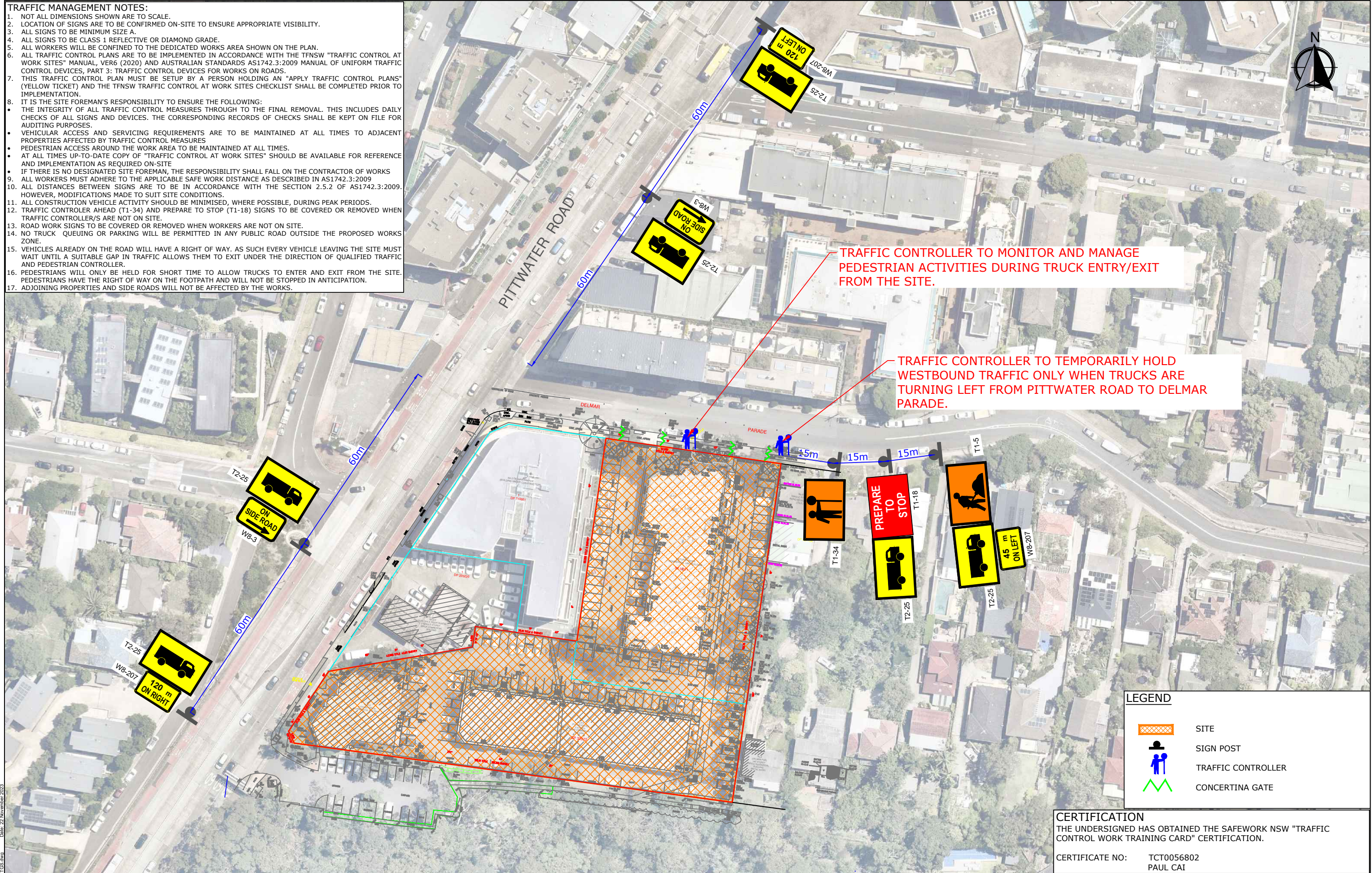

TRAFFIC CONTROLLER TO MONITOR AND MANAGE PEDESTRIAN ACTIVITIES DURING TRUCK ENTRY/EXIT FROM THE SITE.

TRAFFIC CONTROLLER TO TEMPORARILY HOLD WESTBOUND TRAFFIC ONLY WHEN TRUCKS ARE TURNING LEFT FROM PITTWATER ROAD TO DELMAR PARADE.

LEGEND

	SITE
	SIGN POST
	TRAFFIC CONTROLLER
	CONCERTINA GATE

CERTIFICATION
 THE UNDERSIGNED HAS OBTAINED THE SAFEWORK NSW "TRAFFIC CONTROL WORK TRAINING CARD" CERTIFICATION.

CERTIFICATE NO: TCT0056802
 PAUL CAI

REV.	DESCRIPTION	DRAWN	CHECK	APP'D	DATE
A	ISSUE FOR DISCUSSION	HT	PC	KH	24/10/23
B	ISSUE FOR DISCUSSION	HT	PC	KH	22/11/23



PROJECT
4 DELMAR PARADE & 812 PITTWATER ROAD, DEE WHY

TITLE
**TRAFFIC GUIDANCE SCHEME
 EXCAVATION STAGE**

DWG No.	21205CAD021		
	FIGURE_1		
DATE STAMP	22 NOVEMBER 2023		
PROJECT No.	SCALE	REV.	
21205	1:1000 @A3	B	

Filename: 21205CAD021-231122-CTMP_TCS.dwg Date: 22 November 2023

TRAFFIC MANAGEMENT NOTES:

1. NOT ALL DIMENSIONS SHOWN ARE TO SCALE.
2. LOCATION OF SIGNS ARE TO BE CONFIRMED ON-SITE TO ENSURE APPROPRIATE VISIBILITY.
3. ALL SIGNS TO BE MINIMUM SIZE A.
4. ALL SIGNS TO BE CLASS 1 REFLECTIVE OR DIAMOND GRADE.
5. ALL WORKERS WILL BE CONFINED TO THE DEDICATED WORKS AREA SHOWN ON THE PLAN.
6. ALL TRAFFIC CONTROL PLANS ARE TO BE IMPLEMENTED IN ACCORDANCE WITH THE TFNSW "TRAFFIC CONTROL AT WORK SITES" MANUAL, VER6 (2020) AND AUSTRALIAN STANDARDS AS1742.3:2009 MANUAL OF UNIFORM TRAFFIC CONTROL DEVICES, PART 3: TRAFFIC CONTROL DEVICES FOR WORKS ON ROADS.
7. THIS TRAFFIC CONTROL PLAN MUST BE SETUP BY A PERSON HOLDING AN "APPLY TRAFFIC CONTROL PLANS" (YELLOW TICKET) AND THE TFNSW TRAFFIC CONTROL AT WORK SITES CHECKLIST SHALL BE COMPLETED PRIOR TO IMPLEMENTATION.
8. IT IS THE SITE FOREMAN'S RESPONSIBILITY TO ENSURE THE FOLLOWING:
 - THE INTEGRITY OF ALL TRAFFIC CONTROL MEASURES THROUGH TO THE FINAL REMOVAL. THIS INCLUDES DAILY CHECKS OF ALL SIGNS AND DEVICES. THE CORRESPONDING RECORDS OF CHECKS SHALL BE KEPT ON FILE FOR AUDITING PURPOSES.
 - VEHICULAR ACCESS AND SERVICING REQUIREMENTS ARE TO BE MAINTAINED AT ALL TIMES TO ADJACENT PROPERTIES AFFECTED BY TRAFFIC CONTROL MEASURES
 - PEDESTRIAN ACCESS AROUND THE WORK AREA TO BE MAINTAINED AT ALL TIMES.
 - AT ALL TIMES UP-TO-DATE COPY OF "TRAFFIC CONTROL AT WORK SITES" SHOULD BE AVAILABLE FOR REFERENCE AND IMPLEMENTATION AS REQUIRED ON-SITE
 - IF THERE IS NO DESIGNATED SITE FOREMAN, THE RESPONSIBILITY SHALL FALL ON THE CONTRACTOR OF WORKS
9. ALL WORKERS MUST ADHERE TO THE APPLICABLE SAFE WORK DISTANCE AS DESCRIBED IN AS1742.3:2009
10. ALL DISTANCES BETWEEN SIGNS ARE TO BE IN ACCORDANCE WITH THE SECTION 2.5.2 OF AS1742.3:2009. HOWEVER, MODIFICATIONS MADE TO SUIT SITE CONDITIONS.
11. ALL CONSTRUCTION VEHICLE ACTIVITY SHOULD BE MINIMISED, WHERE POSSIBLE, DURING PEAK PERIODS.
12. TRAFFIC CONTROLLER AHEAD (T1-34) AND PREPARE TO STOP (T1-18) SIGNS TO BE COVERED OR REMOVED WHEN TRAFFIC CONTROLLER/S ARE NOT ON SITE.
13. ROAD WORK SIGNS TO BE COVERED OR REMOVED WHEN WORKERS ARE NOT ON SITE.
14. NO TRUCK QUEUING OR PARKING WILL BE PERMITTED IN ANY PUBLIC ROAD OUTSIDE THE PROPOSED WORKS ZONE.
15. VEHICLES ALREADY ON THE ROAD WILL HAVE A RIGHT OF WAY. AS SUCH EVERY VEHICLE LEAVING THE SITE MUST WAIT UNTIL A SUITABLE GAP IN TRAFFIC ALLOWS THEM TO EXIT UNDER THE DIRECTION OF QUALIFIED TRAFFIC AND PEDESTRIAN CONTROLLER.
16. PEDESTRIANS WILL ONLY BE HELD FOR SHORT TIME TO ALLOW TRUCKS TO ENTER AND EXIT FROM THE SITE. PEDESTRIANS HAVE THE RIGHT OF WAY ON THE FOOTPATH AND WILL NOT BE STOPPED IN ANTICIPATION.
17. ADJOINING PROPERTIES AND SIDE ROADS WILL NOT BE AFFECTED BY THE WORKS.

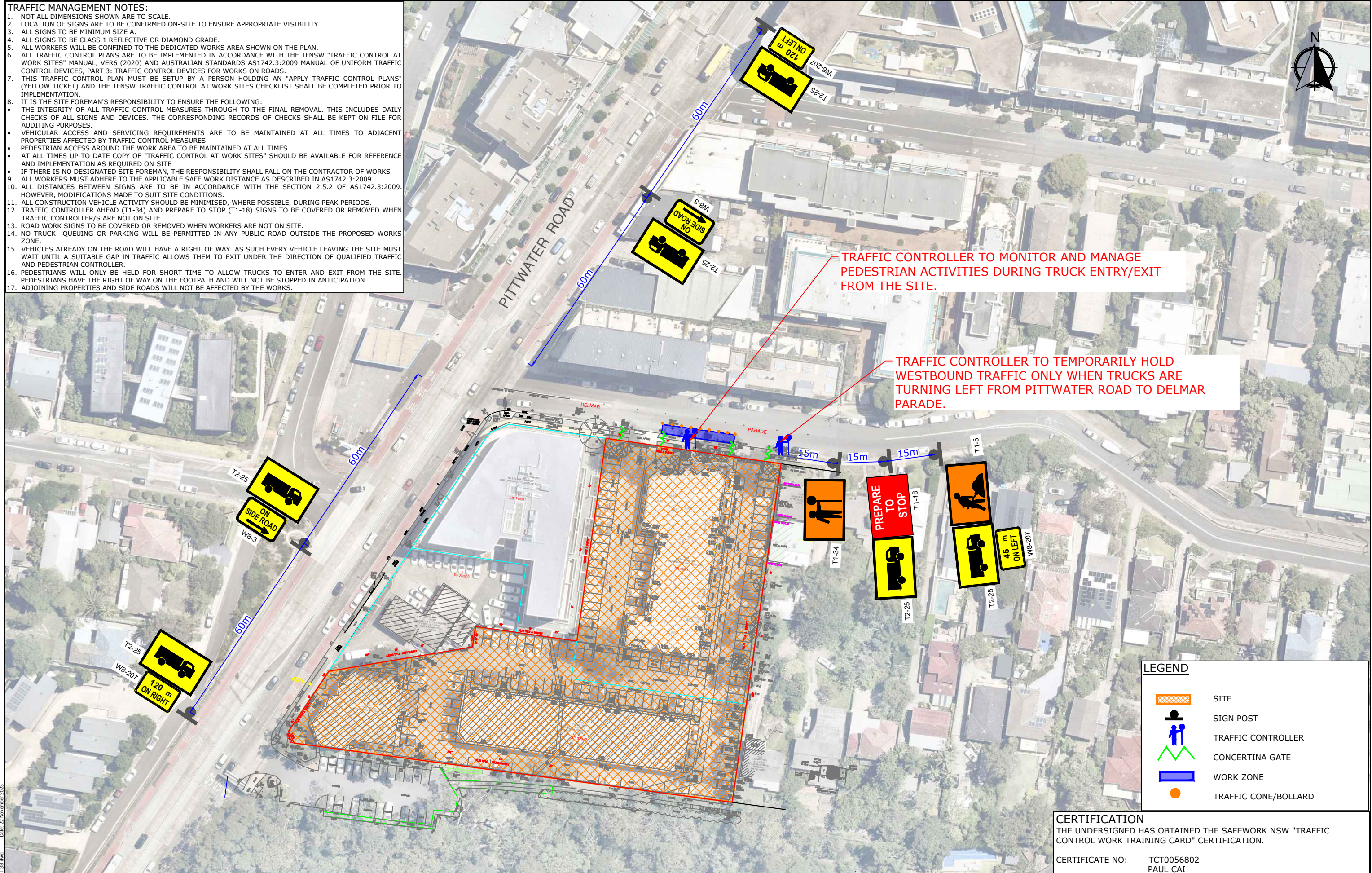

LEGEND	
	SITE
	SIGN POST
	TRAFFIC CONTROLLER
	CONCERTINA GATE
	WORK ZONE
	TRAFFIC CONE/BOLLARD

CERTIFICATION
 THE UNDERSIGNED HAS OBTAINED THE SAFESWORK NSW "TRAFFIC CONTROL WORK TRAINING CARD" CERTIFICATION.
 CERTIFICATE NO: TCT0056802
 PAUL CAI

REV.	DESCRIPTION	DRAWN	CHECK	APP'D	DATE
A	ISSUE FOR DISCUSSION	HT	PC	KH	24/10/23
B	ISSUE FOR DISCUSSION	HT	PC	KH	22/11/23



PROJECT
4 DELMAR PARADE & 812 PITWATER ROAD, DEE WHY

TITLE
**TRAFFIC GUIDANCE SCHEME
 CONSTRUCTION, FIT-OUT AND FINISHES**

DWG No. 21205CAD021		REV. B	
DATE STAMP 22 NOVEMBER 2023			
PROJECT No. 21205	SCALE 1:1000 @A3		

File name: 21205CAD021-231122-CTMP TCS.dwg Date: 22 November 2023

TRAFFIC MANAGEMENT NOTES:

1. NOT ALL DIMENSIONS SHOWN ARE TO SCALE.
2. LOCATION OF SIGNS ARE TO BE CONFIRMED ON-SITE TO ENSURE APPROPRIATE VISIBILITY.
3. ALL SIGNS TO BE MINIMUM SIZE A.
4. ALL SIGNS TO BE CLASS 1 REFLECTIVE OR DIAMOND GRADE.
5. ALL WORKERS WILL BE CONFINED TO THE DEDICATED WORKS AREA SHOWN ON THE PLAN.
6. ALL TRAFFIC CONTROL PLANS ARE TO BE IMPLEMENTED IN ACCORDANCE WITH THE TFNSW "TRAFFIC CONTROL AT WORK SITES" MANUAL, VER6 (2020) AND AUSTRALIAN STANDARDS AS1742.3:2009 MANUAL OF UNIFORM TRAFFIC CONTROL DEVICES, PART 3: TRAFFIC CONTROL DEVICES FOR WORKS ON ROADS.
7. THIS TRAFFIC CONTROL PLAN MUST BE SETUP BY A PERSON HOLDING AN "APPLY TRAFFIC CONTROL PLANS" (YELLOW TICKET) AND THE TFNSW TRAFFIC CONTROL AT WORK SITES CHECKLIST SHALL BE COMPLETED PRIOR TO IMPLEMENTATION.
8. IT IS THE SITE FOREMAN'S RESPONSIBILITY TO ENSURE THE FOLLOWING:
 - THE INTEGRITY OF ALL TRAFFIC CONTROL MEASURES THROUGH TO THE FINAL REMOVAL. THIS INCLUDES DAILY CHECKS OF ALL SIGNS AND DEVICES. THE CORRESPONDING RECORDS OF CHECKS SHALL BE KEPT ON FILE FOR AUDITING PURPOSES.
 - VEHICULAR ACCESS AND SERVICING REQUIREMENTS ARE TO BE MAINTAINED AT ALL TIMES TO ADJACENT PROPERTIES AFFECTED BY TRAFFIC CONTROL MEASURES
 - PEDESTRIAN ACCESS AROUND THE WORK AREA TO BE MAINTAINED AT ALL TIMES.
 - AT ALL TIMES UP-TO-DATE COPY OF "TRAFFIC CONTROL AT WORK SITES" SHOULD BE AVAILABLE FOR REFERENCE AND IMPLEMENTATION AS REQUIRED ON-SITE
 - IF THERE IS NO DESIGNATED SITE FOREMAN, THE RESPONSIBILITY SHALL FALL ON THE CONTRACTOR OF WORKS
9. ALL WORKERS MUST ADHERE TO THE APPLICABLE SAFE WORK DISTANCE AS DESCRIBED IN AS1742.3:2009
10. ALL DISTANCES BETWEEN SIGNS ARE TO BE IN ACCORDANCE WITH THE SECTION 2.5.2 OF AS1742.3:2009. HOWEVER, MODIFICATIONS MADE TO SUIT SITE CONDITIONS.
11. ALL CONSTRUCTION VEHICLE ACTIVITY SHOULD BE MINIMISED, WHERE POSSIBLE, DURING PEAK PERIODS.
12. ROAD WORK SIGNS TO BE COVERED OR REMOVED WHEN WORKERS ARE NOT ON SITE.
13. NO TRUCK QUEUING OR PARKING WILL BE PERMITTED IN ANY PUBLIC ROAD OUTSIDE THE PROPOSED WORKS ZONE.
14. VEHICLES ALREADY ON THE ROAD WILL HAVE A RIGHT OF WAY. AS SUCH EVERY VEHICLE LEAVING THE SITE MUST WAIT UNTIL A SUITABLE GAP IN TRAFFIC ALLOWS THEM TO EXIT UNDER THE DIRECTION OF QUALIFIED TRAFFIC AND PEDESTRIAN CONTROLLER.
15. PEDESTRIANS WILL ONLY BE HELD FOR SHORT TIME TO ALLOW TRUCKS TO ENTER AND EXIT FROM THE SITE. PEDESTRIANS HAVE THE RIGHT OF WAY ON THE FOOTPATH AND WILL NOT BE STOPPED IN ANTICIPATION.
16. ADJOINING PROPERTIES AND SIDE ROADS WILL NOT BE AFFECTED BY THE WORKS.

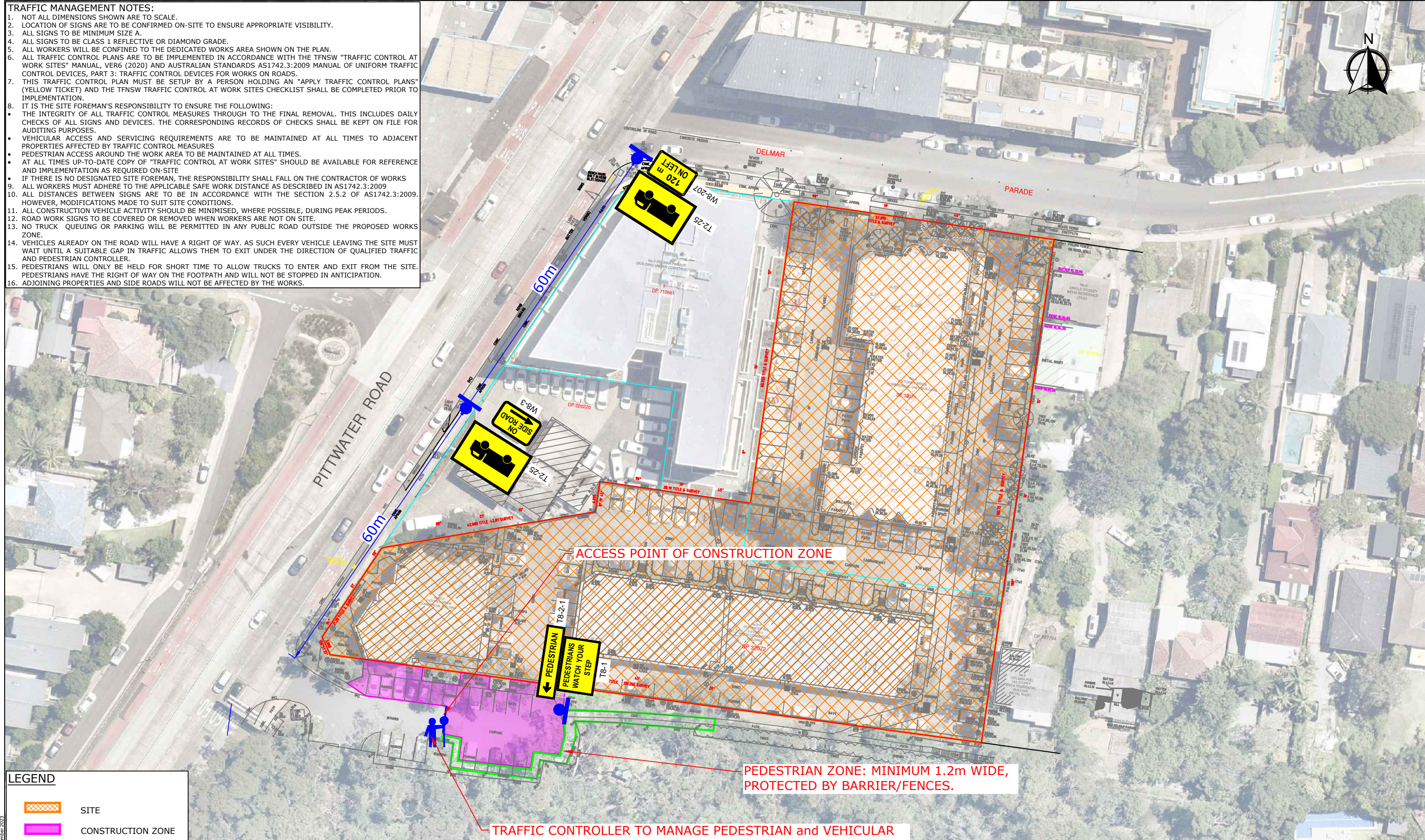

LEGEND

	SITE
	CONSTRUCTION ZONE
	SIGN POST
	TRAFFIC CONTROLLER
	PEDESTRIAN FENCE

REV.	DESCRIPTION	DRAWN	CHECK	APP'D	DATE
A	ISSUE FOR DISCUSSION	HT	PC	KH	24/10/23
B	ISSUE FOR DISCUSSION	HT	PC	KH	22/11/23



PROJECT
4 DELMAR PARADE & 812 PITWATER ROAD, DEE WHY

TITLE
TRAFFIC GUIDANCE SCHEME
FOR TRUCK ACCESS VIA STONY RANGE CAR PARK

CERTIFICATION
THE UNDERSIGNED HAS OBTAINED THE SAFESWORK NSW "TRAFFIC CONTROL WORK TRAINING CARD" CERTIFICATION.

CERTIFICATE NO: TCT0056802
PAUL CAI

DWG No.	21205CAD021	
	FIGURE_3	
DATE STAMP	22 NOVEMBER 2023	
PROJECT No.	SCALE	REV.
21205	1:700 @A3	B

Filename: 21205CAD021-211122-CTMP_TCS.dwg Date: 22 November 2023

Appendix B

Swept Path Analysis

VEHICLE ENTERING

VEHICLE EXITING

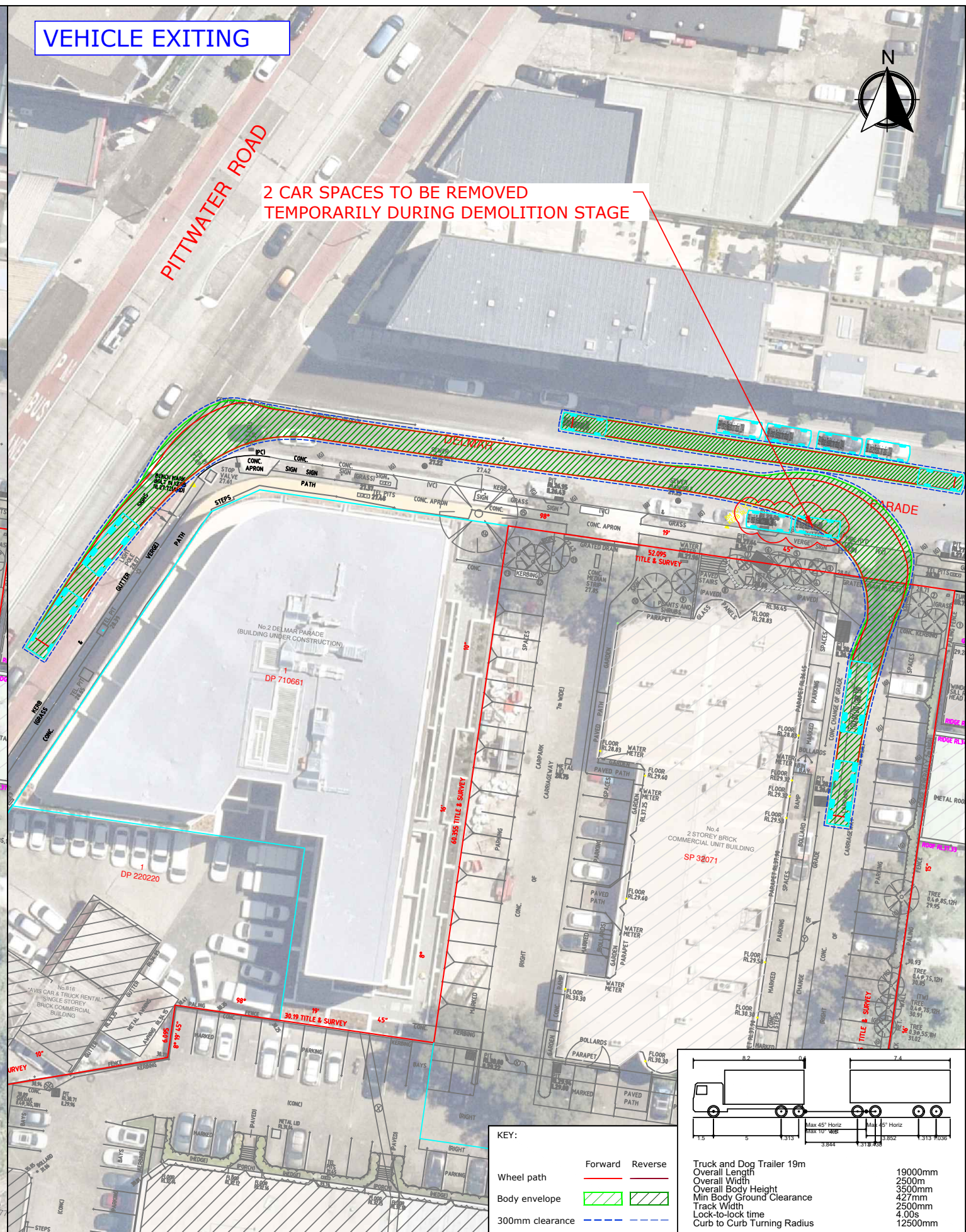

2 CAR SPACES TO BE REMOVED TEMPORARILY DURING DEMOLITION STAGE

KEY:

Wheel path	Forward	Reverse
Body envelope		
300mm clearance		

REV.	DESCRIPTION	DRAWN	CHECK	APP'D	DATE
A	ISSUE FOR DISCUSSION	HT	PC	KH	24/10/23
B	ISSUE FOR DISCUSSION	HT	PC	KH	17/11/23



PROJECT
4 DELMAR PARADE & 812 PITWATER ROAD, DEE WHY

TITLE
SWEPT PATH ANALYSIS - EXCAVATION STAGE
19m TRUCK & DOG TRAILER ACCESSES THE SITE - RIGHT TURN FROM PITWATER ROAD

DWG No.	21205CAD020
FIGURE 1	
DATE STAMP 17 NOVEMBER 2023	
PROJECT No.	21205
SCALE	1:550 @A3
REV.	B

Date: 17 November 2023
Filename: 21205CAD020-21117-CTM SWEPT PATH.dwg

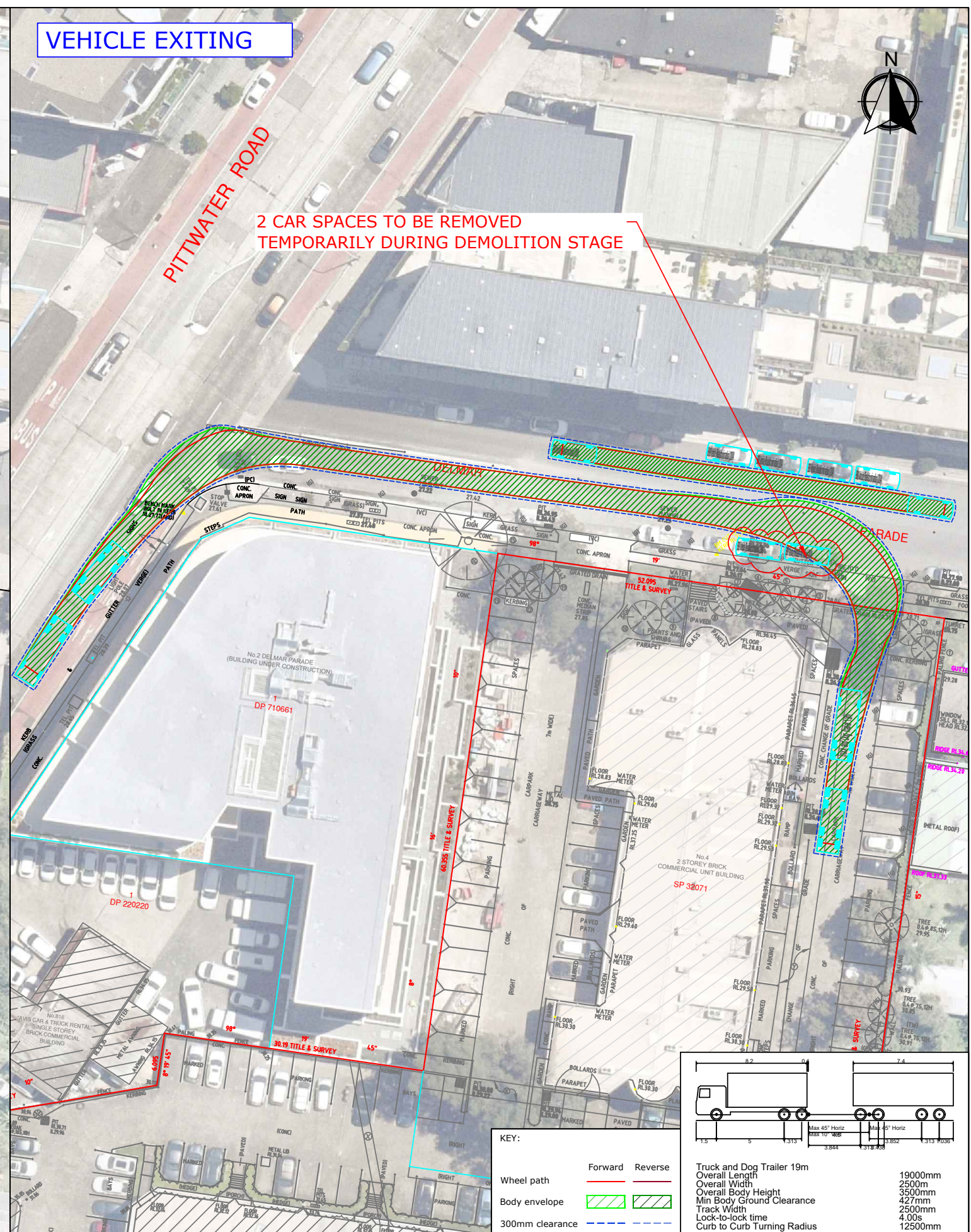
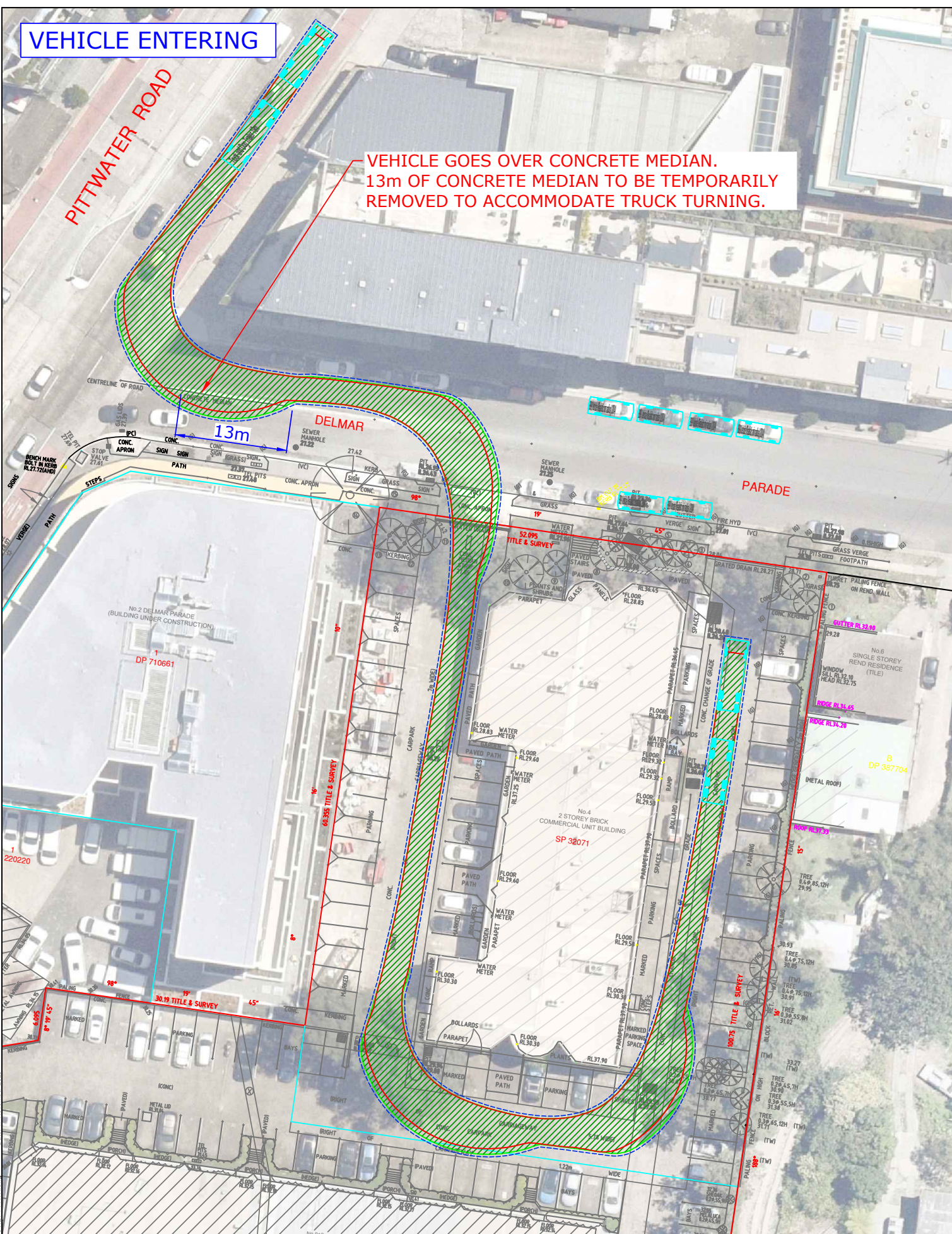

REV.	DESCRIPTION	DRAWN	CHECK	APP'D	DATE
A	ISSUE FOR DISCUSSION	HT	PC	KH	24/10/23
B	ISSUE FOR DISCUSSION	HT	PC	KH	17/11/23



PROJECT
4 DELMAR PARADE & 812 PITTWATER ROAD, DEE WHY

TITLE
SWEPT PATH ANALYSIS - EXCAVATION STAGE
19m TRUCK & DOG TRAILER ACCESSES THE SITE - LEFT TURN FROM PITTWATER ROAD

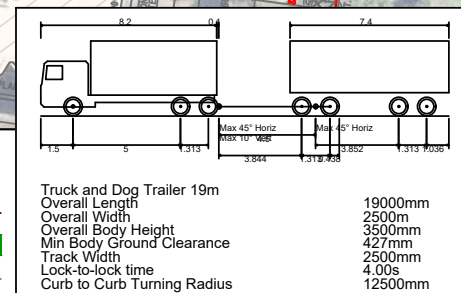

KEY:

Wheel path	Forward	Reverse
Body envelope		
300mm clearance		

Truck and Dog Trailer 19m	19000mm
Overall Length	2500mm
Overall Width	3500mm
Overall Body Height	427mm
Min Body Ground Clearance	2500mm
Track Width	2500mm
Lock-to-lock time	4.00s
Curb to Curb Turning Radius	12500mm

DWG No.	21205CAD020	
	FIGURE 2	
DATE STAMP	17 NOVEMBER 2023	
PROJECT No.	21205	SCALE
		1:550 @A3
REV.		B

Date: 17 November 2023
 Filename: 21205CAD020-21117-CTM-SWEPT PATH.dwg

VEHICLE ENTERING

VEHICLE EXITING

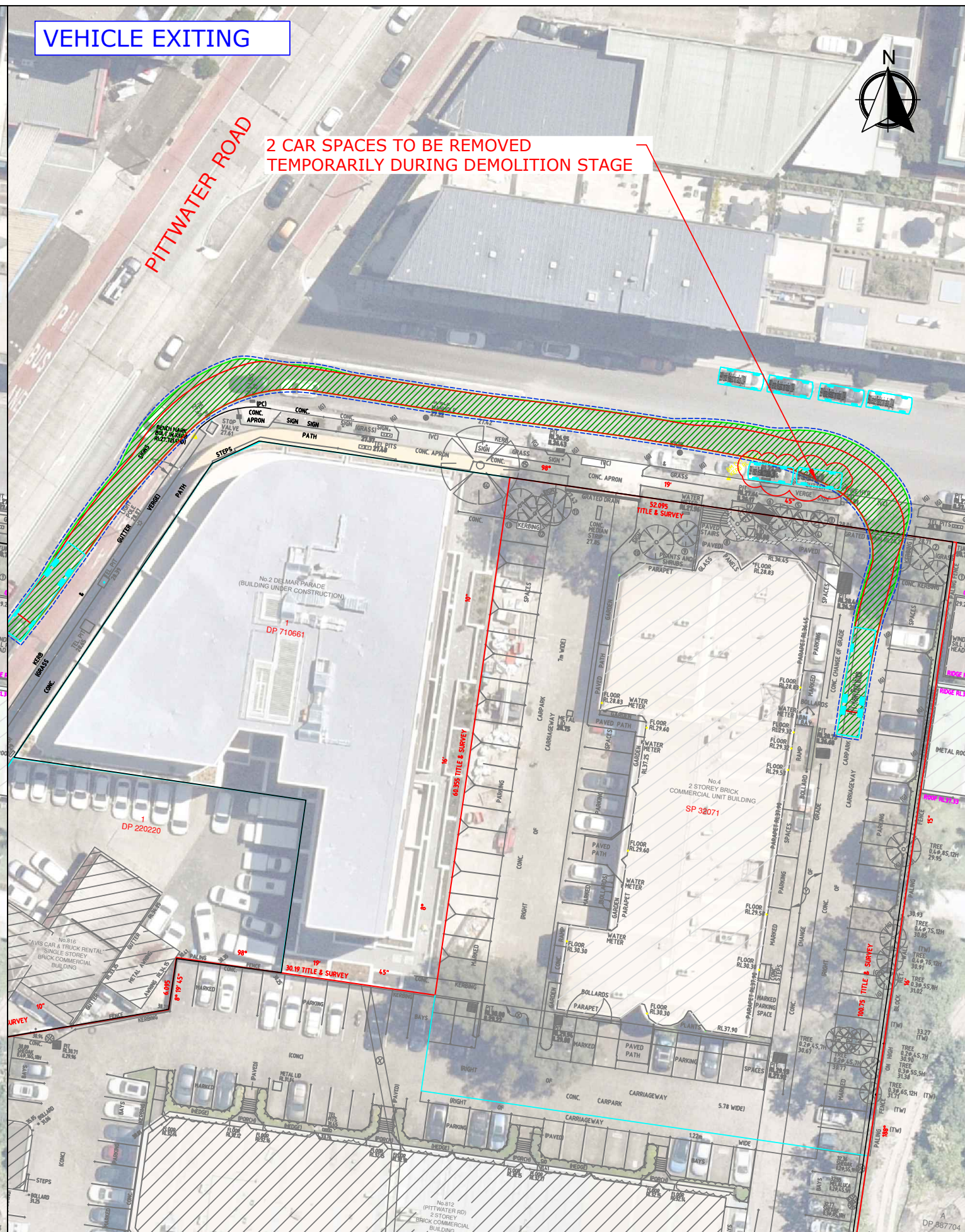
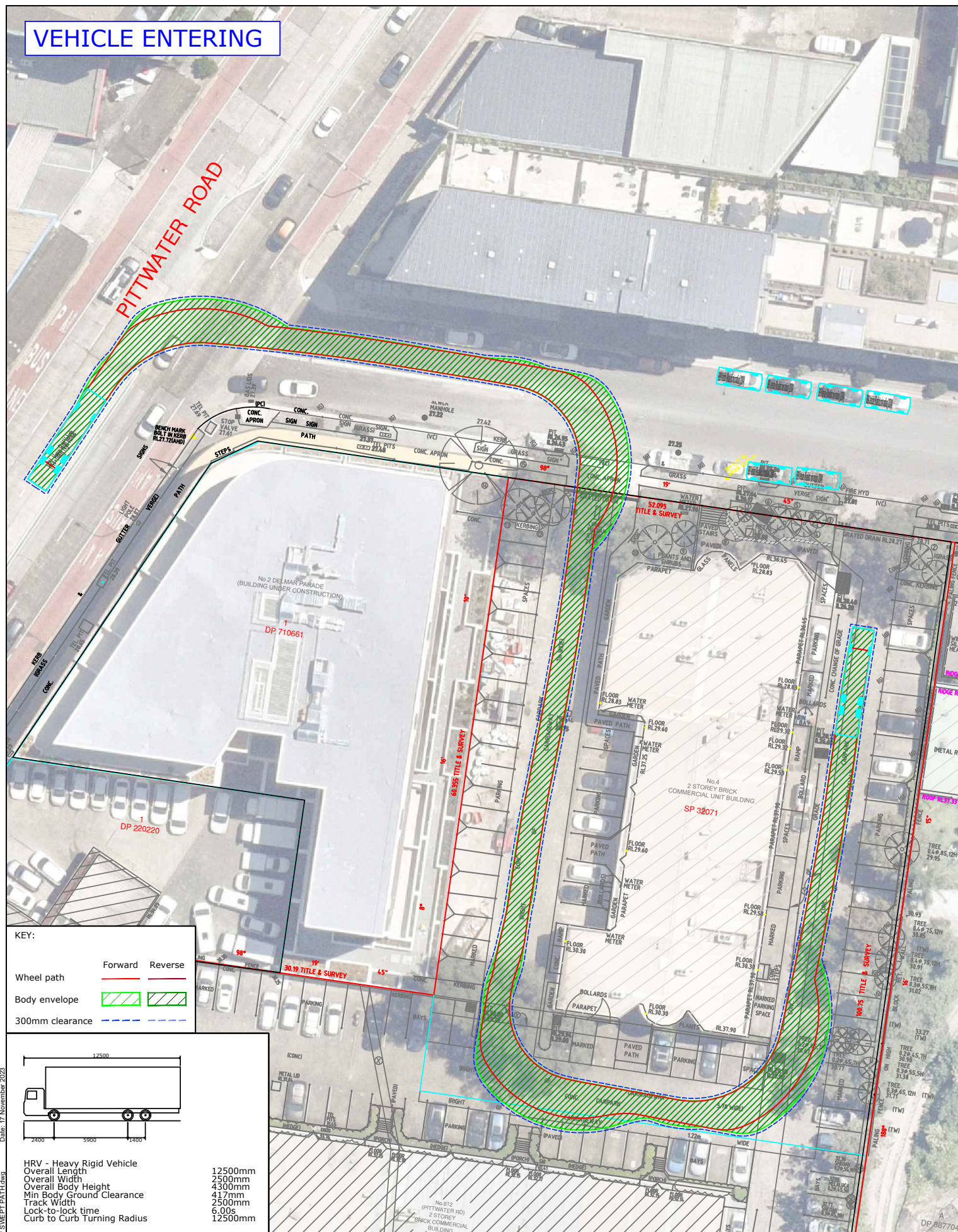

KEY:

Wheel path	Forward	Reverse
Body envelope		
300mm clearance		

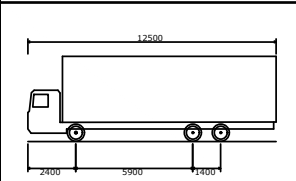

HRV - Heavy Rigid Vehicle
 Overall Length 12500mm
 Overall Width 2500mm
 Overall Body Height 4300mm
 Min Body Ground Clearance 417mm
 Track Width 2500mm
 Lock-to-lock time 6.00s
 Curb to Curb Turning Radius 12500mm

REV.	DESCRIPTION	DRAWN	CHECK	APP'D	DATE
A	ISSUE FOR DISCUSSION	HT	PC	KH	24/10/23
B	ISSUE FOR DISCUSSION	HT	PC	KH	17/11/23



PROJECT
 4 DELMAR PARADE & 812 PITTWATER ROAD, DEE WHY

TITLE
 SWEPT PATH ANALYSIS - EXCAVATION STAGE
 12.5m HEAVY RIGID VEHICLE ACCESSES THE SITE - RIGHT TURN FROM PITTWATER ROAD

DWG No.	21205CAD020	
	FIGURE 3	
DATE STAMP	17 NOVEMBER 2023	
PROJECT No.	SCALE	REV.
21205	1:550 @A3	B

Date: 17 November 2023
 File name: 21205CAD020-21117-CTM-SWEPT PATH.DWG

VEHICLE ENTERING

VEHICLE EXITING



VEHICLE GOES OVER CONCRETE MEDIAN.
13m OF CONCRETE MEDIAN TO BE TEMPORARILY REMOVED TO ACCOMMODATE TRUCK TURNING.

2 CAR SPACES TO BE REMOVED TEMPORARILY DURING DEMOLITION STAGE

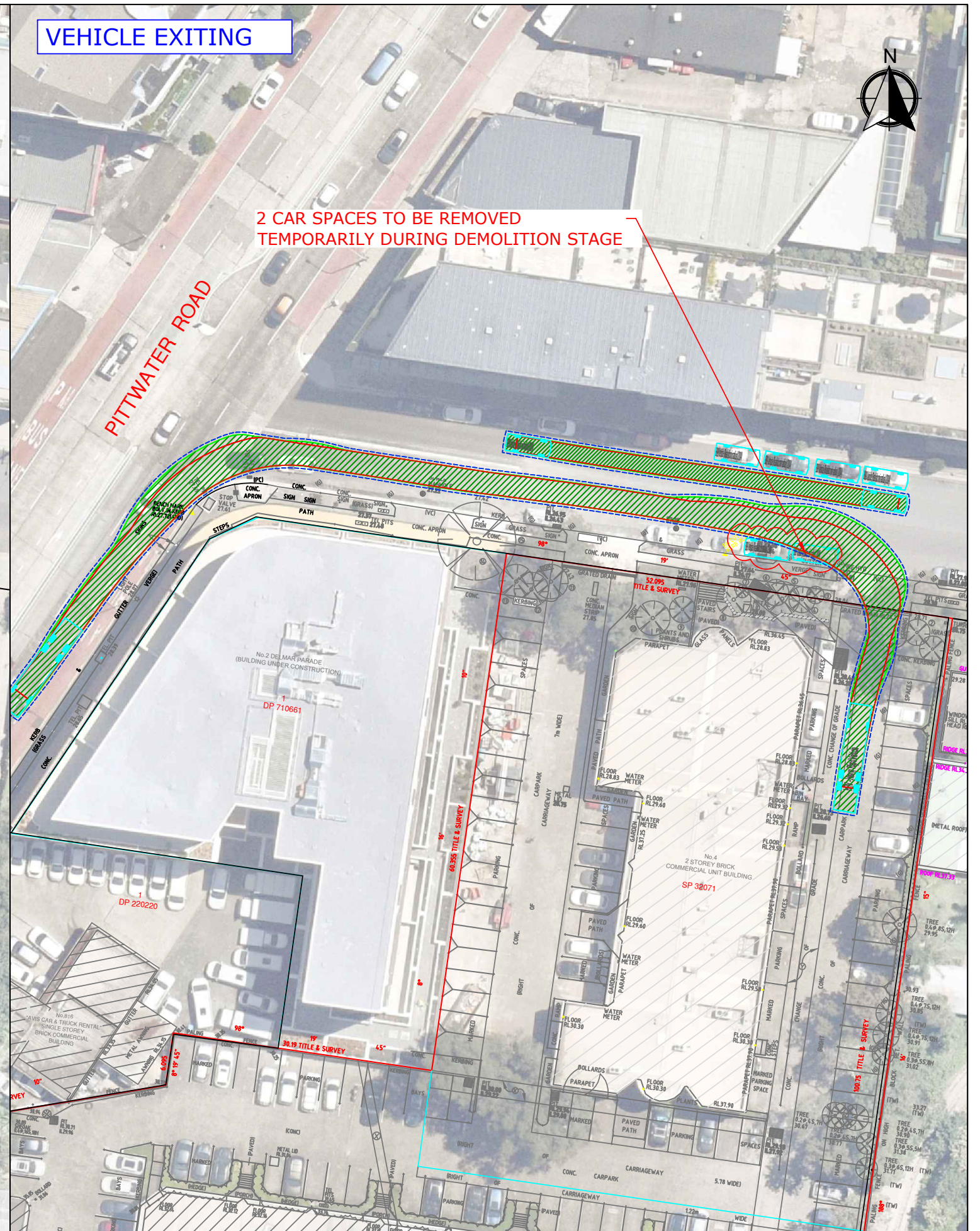
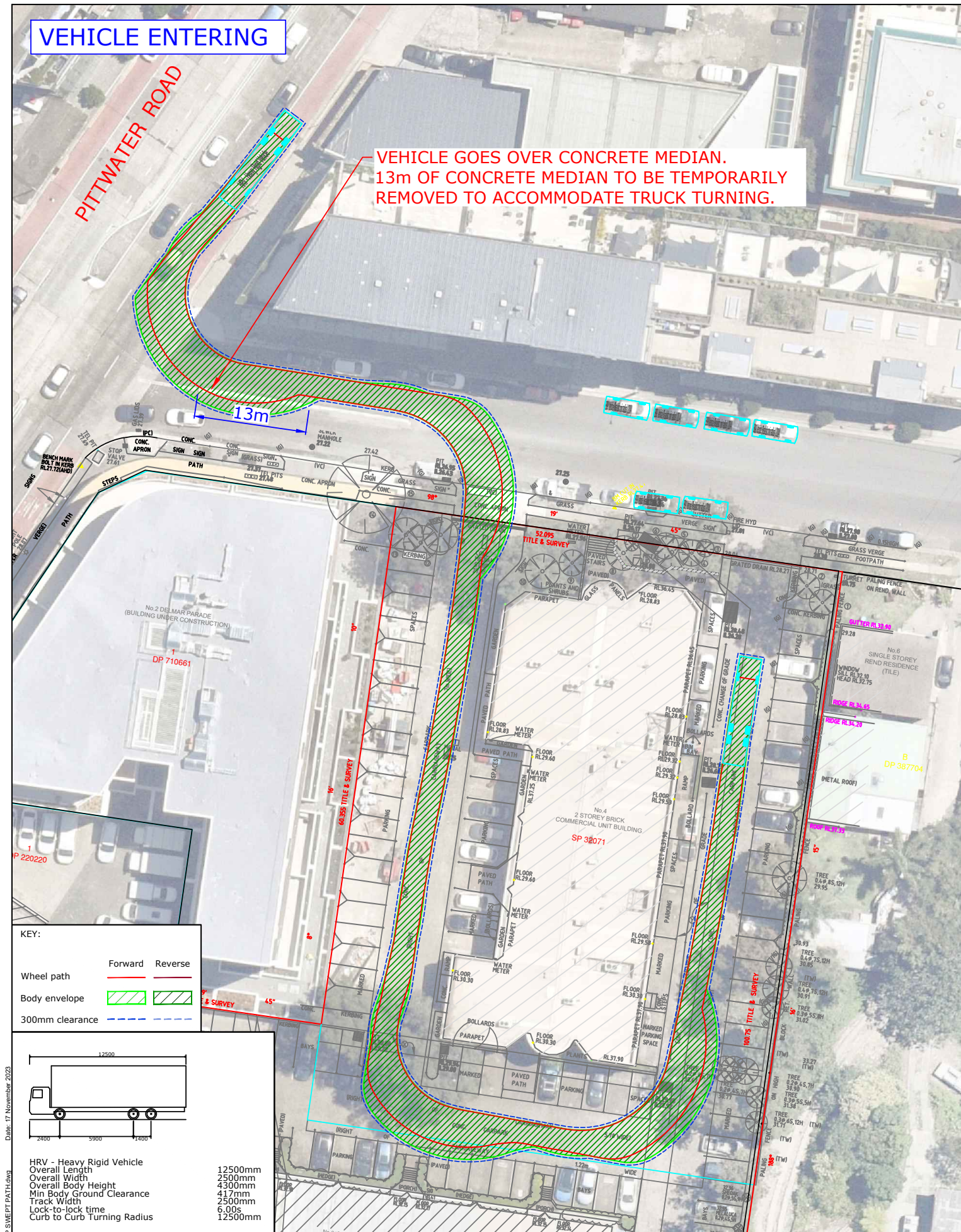

KEY:

Wheel path	Forward	Reverse
Body envelope		
300mm clearance		

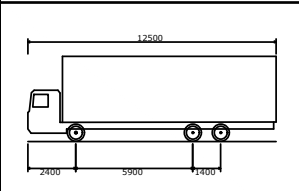

HRV - Heavy Rigid Vehicle
Overall Length 12500mm
Overall Width 2500mm
Overall Body Height 4300mm
Min Body Ground Clearance 417mm
Track Width 2500mm
Lock-to-lock time 6.00s
Curb to Curb Turning Radius 12500mm

REV.	DESCRIPTION	DRAWN	CHECK	APP'D	DATE
A	ISSUE FOR DISCUSSION	HT	PC	KH	24/10/23
B	ISSUE FOR DISCUSSION	HT	PC	KH	17/11/23



PROJECT
4 DELMAR PARADE & 812 PITTWATER ROAD, DEE WHY

TITLE
SWEPT PATH ANALYSIS - EXCAVATION STAGE
12.5m HEAVY RIGID VEHICLE ACCESSES THE SITE - LEFT TURN FROM PITTWATER ROAD

DWG No.	21205CAD020
	FIGURE 4
DATE STAMP	17 NOVEMBER 2023
PROJECT No.	21205
SCALE	1:550 @A3
REV.	B

Date: 17 November 2023
Filename: 21205CAD020-21117-CTM-SWEPT PATH.DWG

VEHICLE ENTERING

VEHICLE EXITING

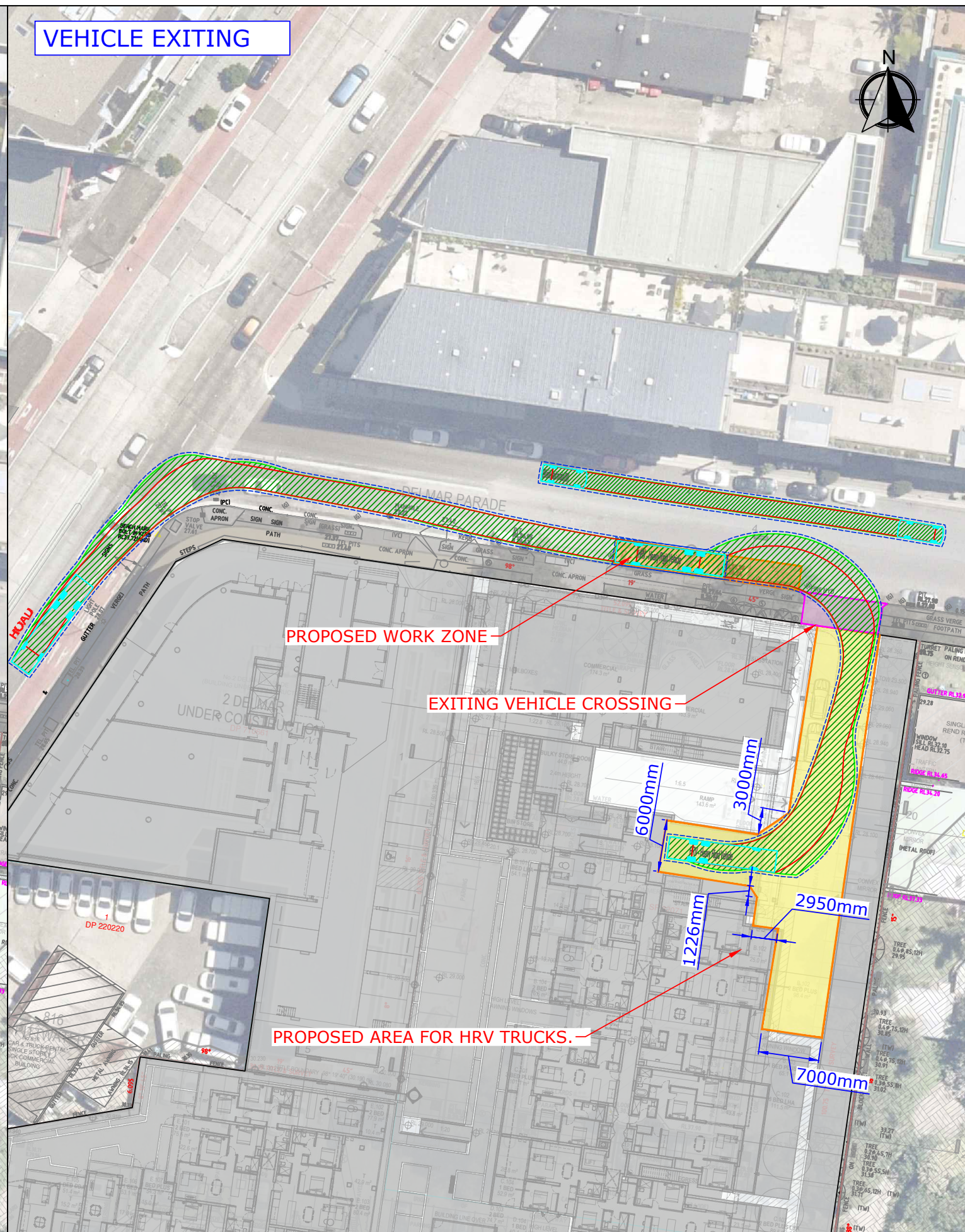
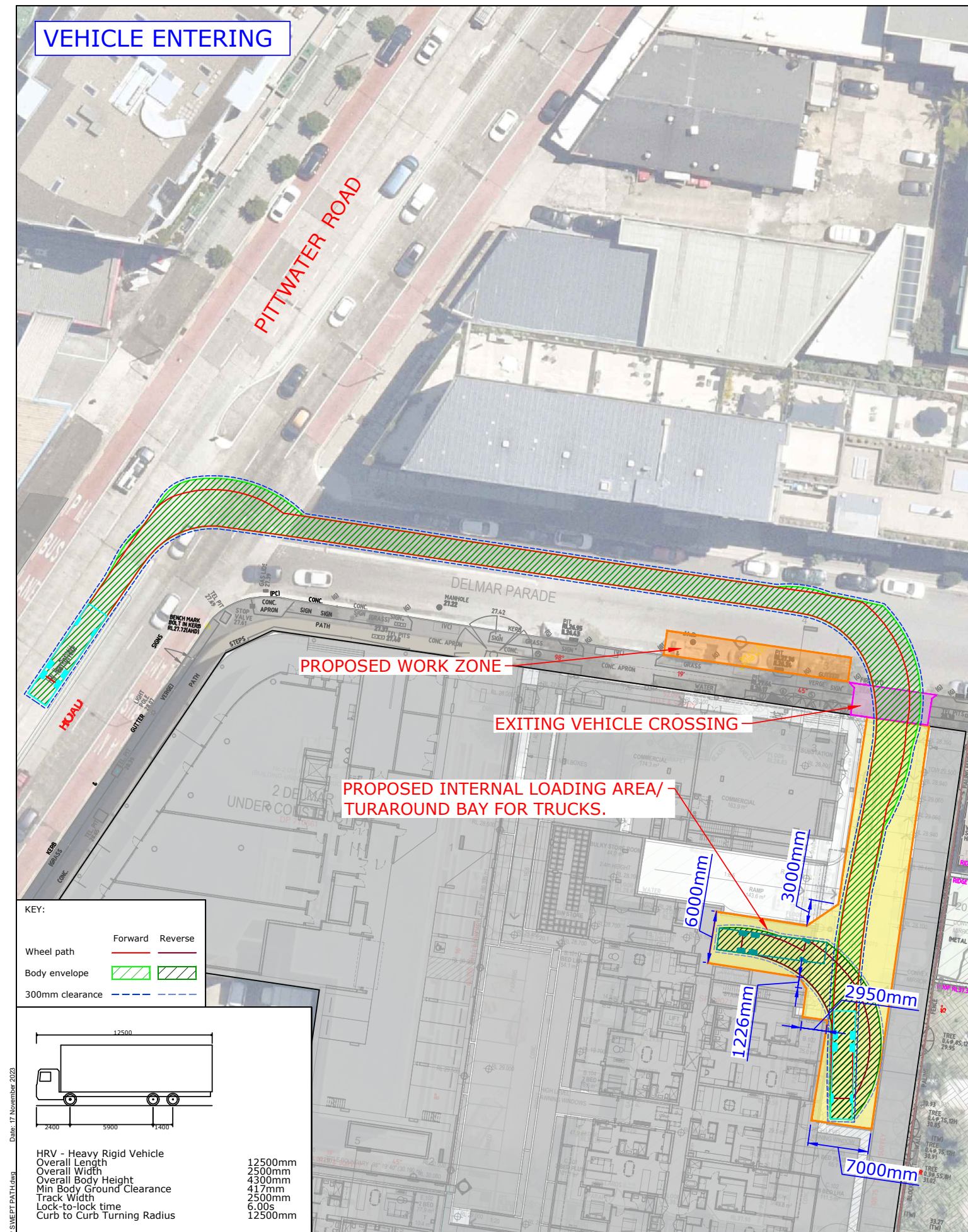

KEY:

Wheel path	Forward	Reverse
Body envelope		
300mm clearance		

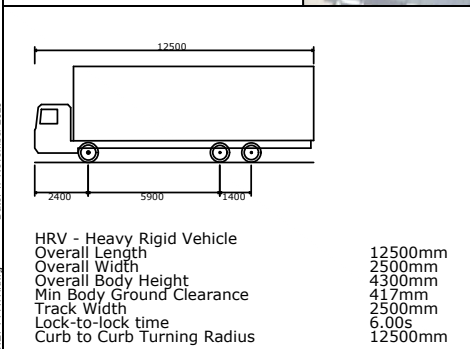

REV.	DESCRIPTION	DRAWN	CHECK	APP'D	DATE
A	ISSUE FOR DISCUSSION	HT	PC	KH	24/10/23
B	ISSUE FOR DISCUSSION	HT	PC	KH	17/11/23



PROJECT
 4 DELMAR PARADE & 812 PITTWATER ROAD, DEE WHY

TITLE
 SWEEP PATH ANALYSIS - CONSTRUCTION STAGE
 12.5m HEAVY RIGID VEHICLE ACCESSES THE SITE/WORK ZONE - RIGHT TURN FROM PITTWATER ROAD

DWG No.	21205CAD020	
	FIGURE 5	
DATE STAMP	17 NOVEMBER 2023	
PROJECT No.	SCALE	REV.
21205	1:550 @A3	A

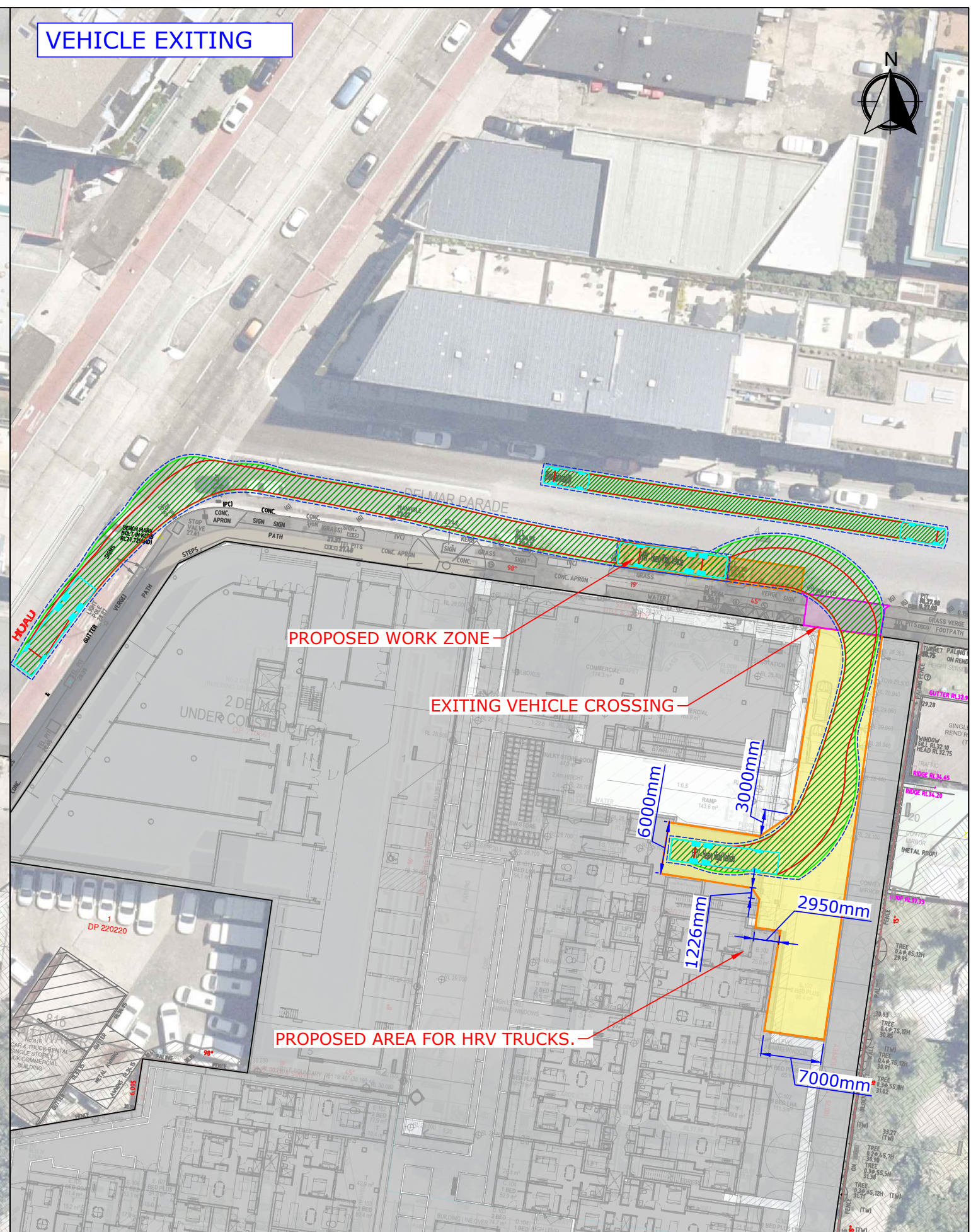
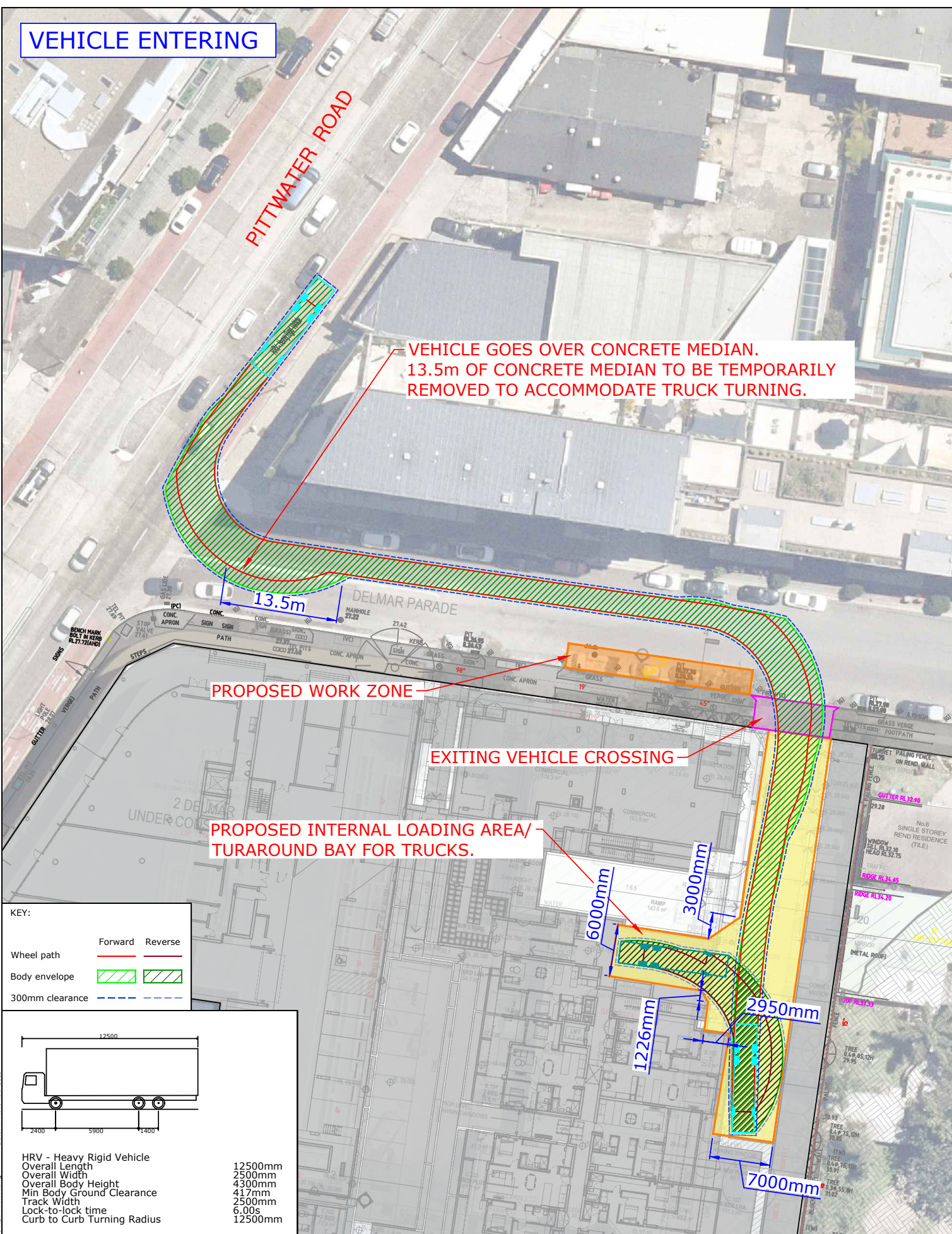

KEY:

Wheel path	Forward	Reverse
Body envelope	Green hatched	Red hatched
300mm clearance	Blue dashed line	

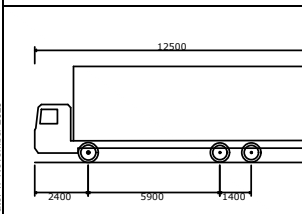

HRV - Heavy Rigid Vehicle	12500mm
Overall Length	2500mm
Overall Width	4300mm
Overall Body Height	417mm
Min Body Ground Clearance	2500mm
Track Width	6.00s
Lock-to-lock time	12500mm
Curb to Curb Turning Radius	

REV.	DESCRIPTION	DRAWN	CHECK	APP'D	DATE
A	ISSUE FOR DISCUSSION	HT	PC	KH	24/10/23
B	ISSUE FOR DISCUSSION	HT	PC	KH	17/11/23



PROJECT
4 DELMAR PARADE & 812 PITTWATER ROAD, DEE WHY

TITLE
SWEPT PATH ANALYSIS - CONSTRUCTION STAGE
12.5m HEAVY RIGID VEHICLE ACCESSES THE SITE/WORK ZONE - LEFT TURN FROM PITTWATER ROAD

DWG No.	21205CAD020	
	FIGURE 6	
DATE STAMP	17 NOVEMBER 2023	
PROJECT No.	SCALE	REV.
21205	1:550 @A3	A

Date: 17 November 2023
Filename: 21205CAD020-21117-CTM-SWEPT PATH.dwg

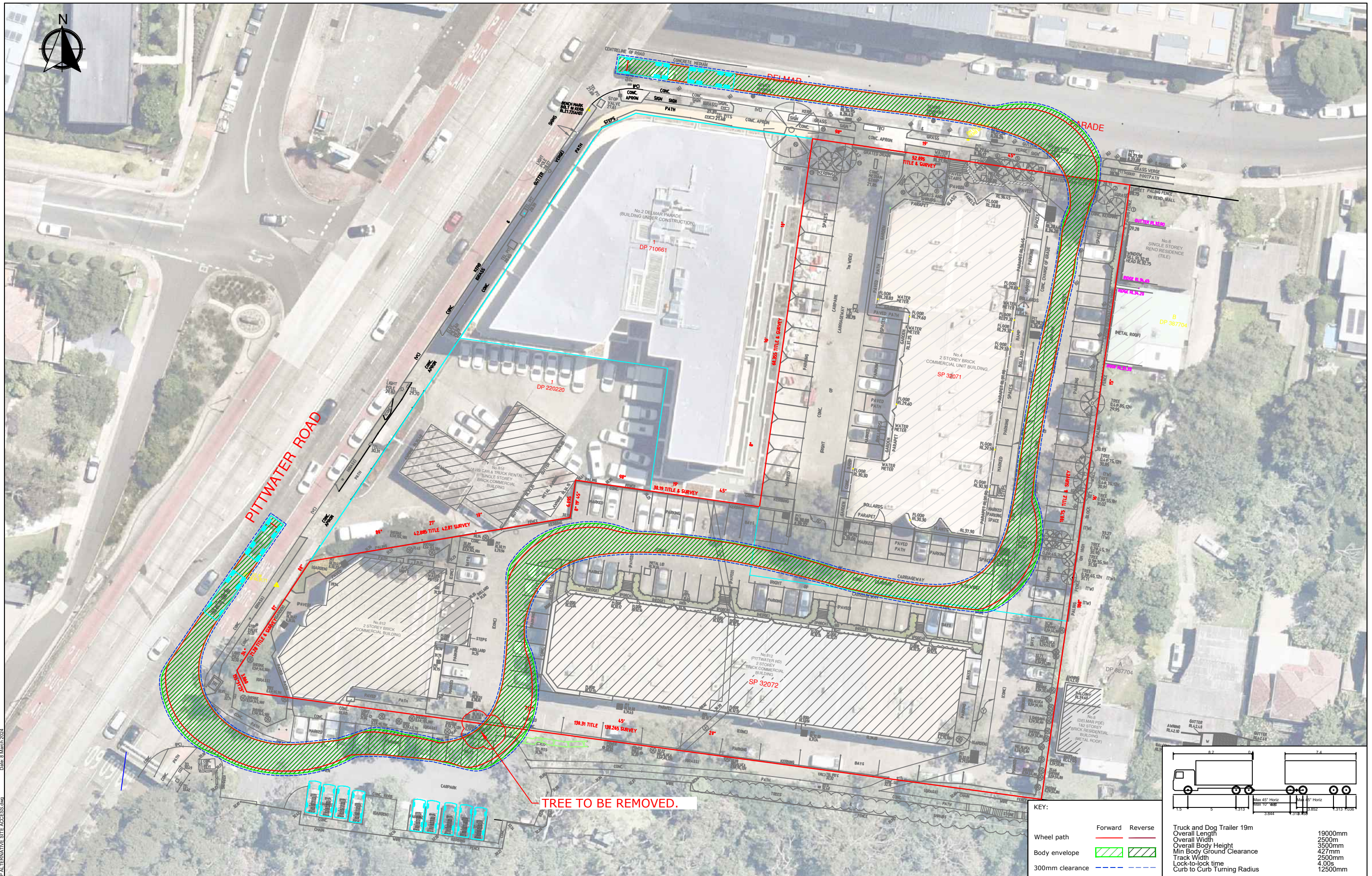

Date: 8 March 2024
Filename: 21205CAD027-240307-CTMP-ALTERNATIVE SITE ACCESS.dwg

REV.	DESCRIPTION	DRAWN	CHECK	APP'D	DATE
A	ISSUE FOR DISCUSSION	HT	PC	KH	07/03/24



PROJECT
4 DELMAR PARADE & 812 PITTWATER ROAD, DEE WHY

TITLE
**SWEPT PATH ANALYSIS
19m TRUCK & DOG TRAILER - VEHICLE DRIVING THROUGH NORTHERN CAR SPACES**

DWG No. 21205CAD027	
FIGURE (1)	
DATE STAMP 07 MARCH 2024	
PROJECT No. 21205	SCALE 1:550 @A3
REV. B	

KEY:		Forward	Reverse
Wheel path			
Body envelope			
300mm clearance			

Truck and Dog Trailer 19m	19000mm
Overall Length	2500mm
Overall Width	3500mm
Overall Body Height	427mm
Min Body Ground Clearance	2500mm
Track Width	4.00m
Lock-to-lock time	12500mm
Curb to Curb Turning Radius	

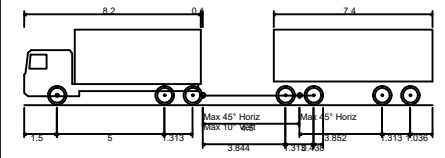

KEY:	Forward	Reverse	
Wheel path			
Body envelope			
300mm clearance			

Truck and Dog Trailer 19m	19000mm
Overall Length	2500mm
Overall Width	3500mm
Overall Body Height	427mm
Min Body Ground Clearance	2500mm
Track Width	4.00m
Lock-to-lock time	12500mm
Curb to Curb Turning Radius	

REV.	DESCRIPTION	DRAWN	CHECK	APP'D	DATE
A	ISSUE FOR DISCUSSION	HT	PC	KH	07/03/24



PROJECT
4 DELMAR PARADE & 812 PITWATER ROAD, DEE WHY

TITLE
**SWEPT PATH ANALYSIS
 19m TRUCK & DOG TRAILER - VEHICLE DRIVING THROUGH PARKING AISLE**

DWG No.	21205CAD027		
	FIGURE (2)		
DATE STAMP	07 MARCH 2024		
PROJECT No.	SCALE	REV.	
21205	1:550 @A3	B	

Date: 6 March 2024
 Filename: 21205CAD027-240307-CTMP-ALTERNATIVE SITE ACCESS.dwg

VEHICLE ENTERING

VEHICLE EXITING

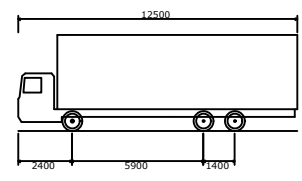
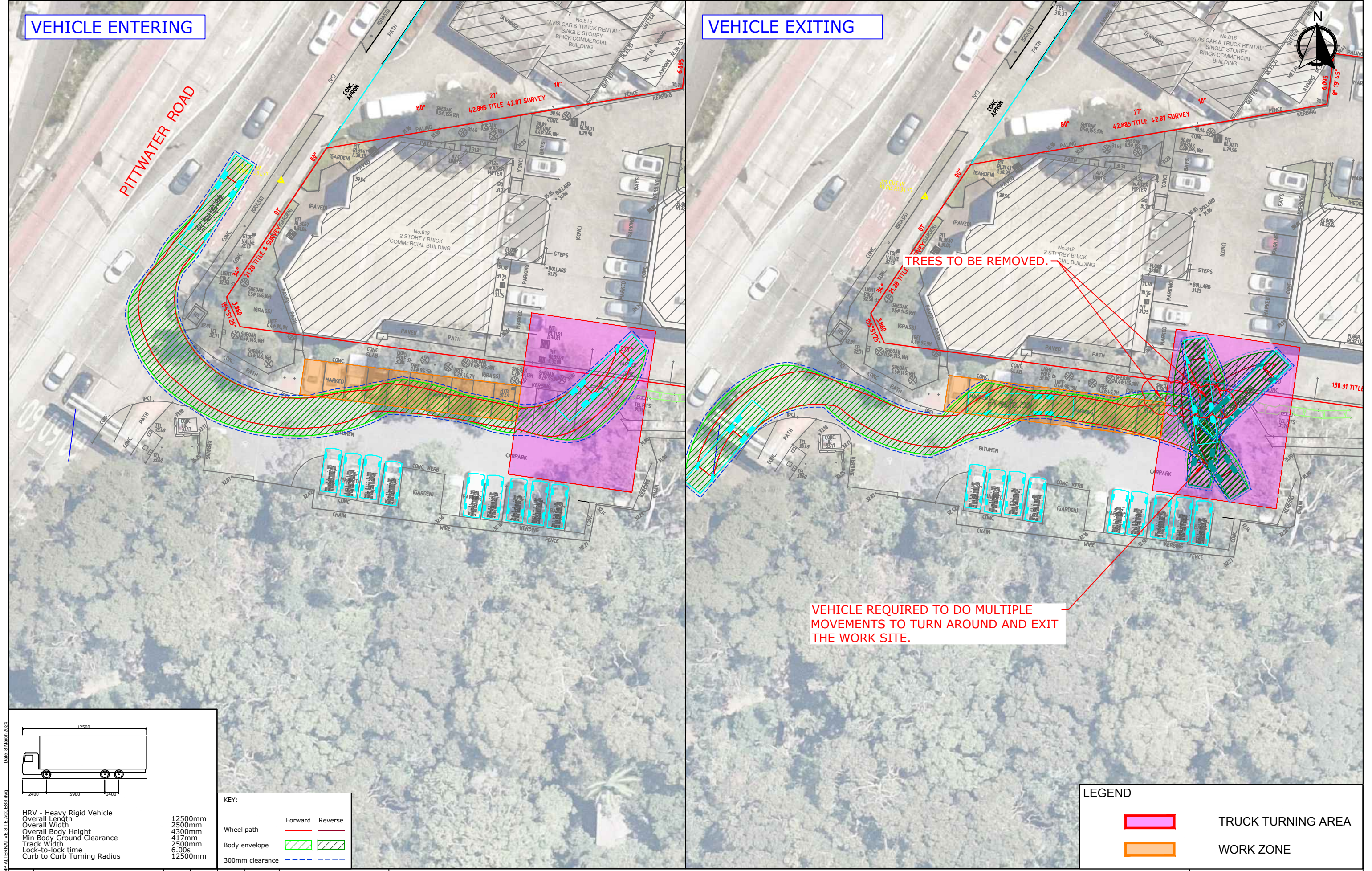

HRV - Heavy Rigid Vehicle
 Overall Length 12500mm
 Overall Width 2400mm
 Overall Body Height 5900mm
 Min Body Ground Clearance 1400mm
 Track Width 2500mm
 Lock-to-lock time 6.00s
 Curb to Curb Turning Radius 12500mm

KEY:

Wheel path	Forward	Reverse
Body envelope		
300mm clearance		

LEGEND

	TRUCK TURNING AREA
	WORK ZONE

REV.	DESCRIPTION	DRAWN	CHECK	APP'D	DATE
A	ISSUE FOR DISCUSSION	HT	PC	KH	07/03/24



PROJECT: 4 DELMAR PARADE & 812 PITWATER ROAD, DEE WHY

TITLE: SWEPT PATH ANALYSIS
 12.5m HEAVY RIGID VEHICLE - VEHICLE DRIVING THROUGH NORTHERN CAR SPACES

DWG No.	21205CAD027		
	FIGURE (3)		
DATE STAMP	07 MARCH 2024		
PROJECT No.	SCALE	REV.	
21205	1:400 @A3	B	

Date: 8 March 2024
 Filename: 21205CAD027-240307-CTMP-ALTERNATIVE SITE ACCESS.dwg

VEHICLE ENTERING

VEHICLE EXITING

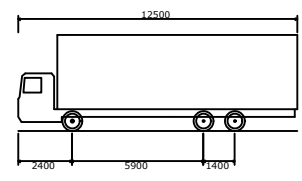
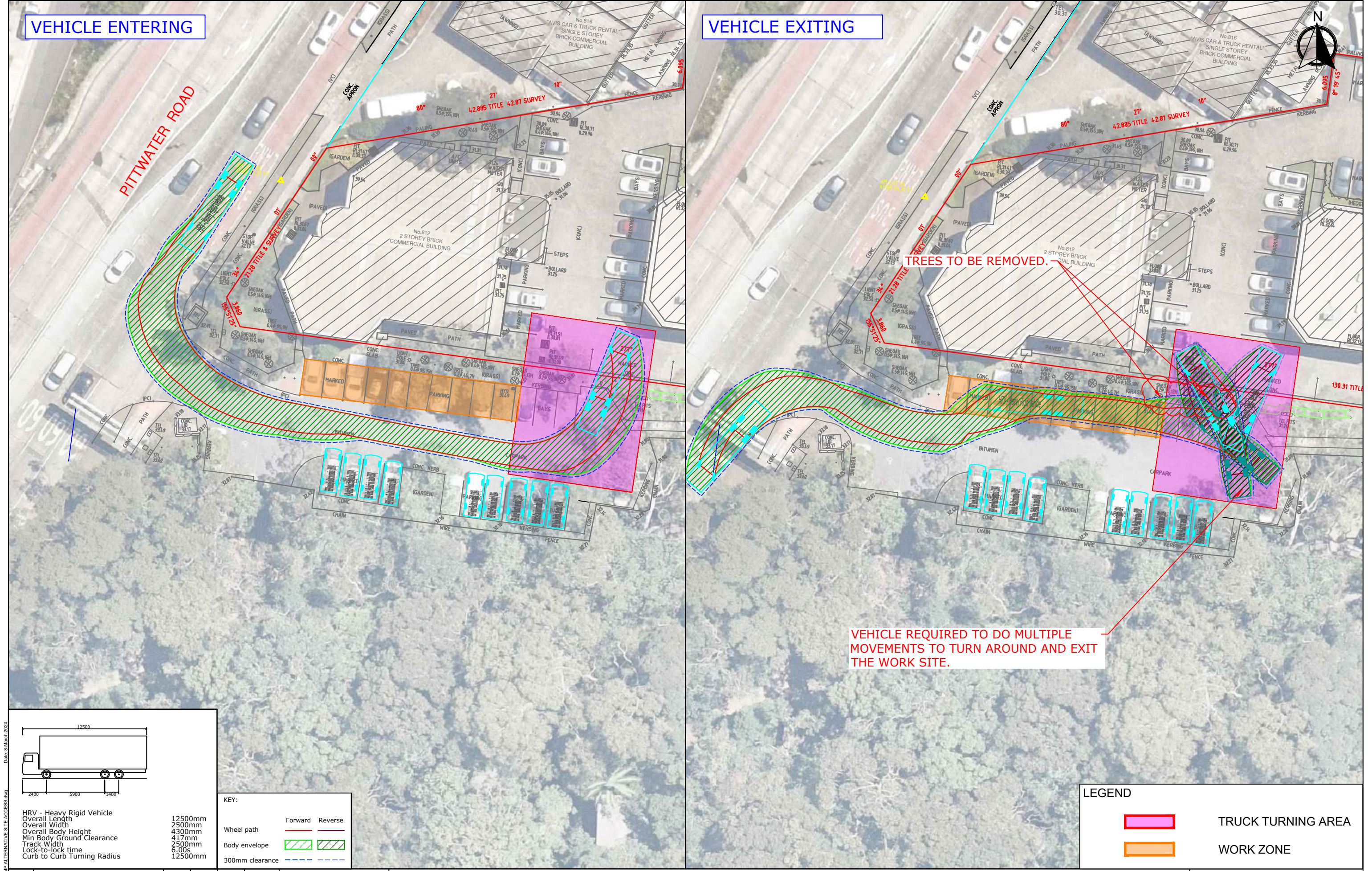

KEY:

Wheel path	Forward	Reverse
Body envelope		
300mm clearance		

LEGEND

	TRUCK TURNING AREA
	WORK ZONE

REV.	DESCRIPTION	DRAWN	CHECK	APP'D	DATE
A	ISSUE FOR DISCUSSION	HT	PC	KH	07/03/24



PROJECT
4 DELMAR PARADE & 812 PITWATER ROAD, DEE WHY

TITLE
**SWEPT PATH ANALYSIS
 12.5m HEAVY RIGID VEHICLE - VEHICLE DRIVING THROUGH PARKING AISLE**

DWG No.	21205CAD027		
	FIGURE (4)		
DATE STAMP	07 MARCH 2024		
PROJECT No.	SCALE	REV.	
21205	1:400 @A3	B	

Date: 8 March 2024
 Filename: 21205CAD027_240307.ctb ALTERNATIVE SITE ACCESS.jpg

VEHICLE ENTERING

VEHICLE EXITING

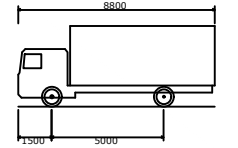
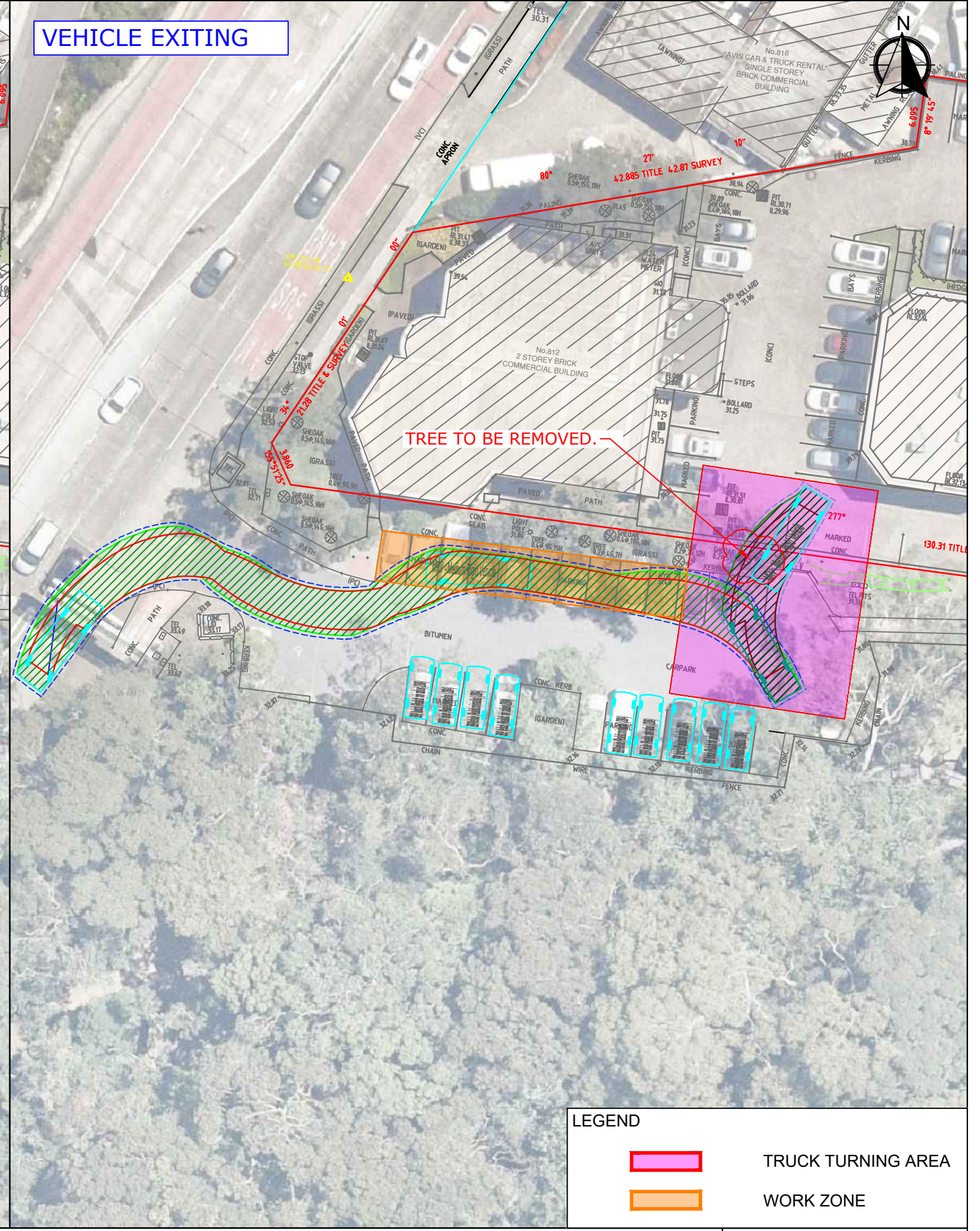
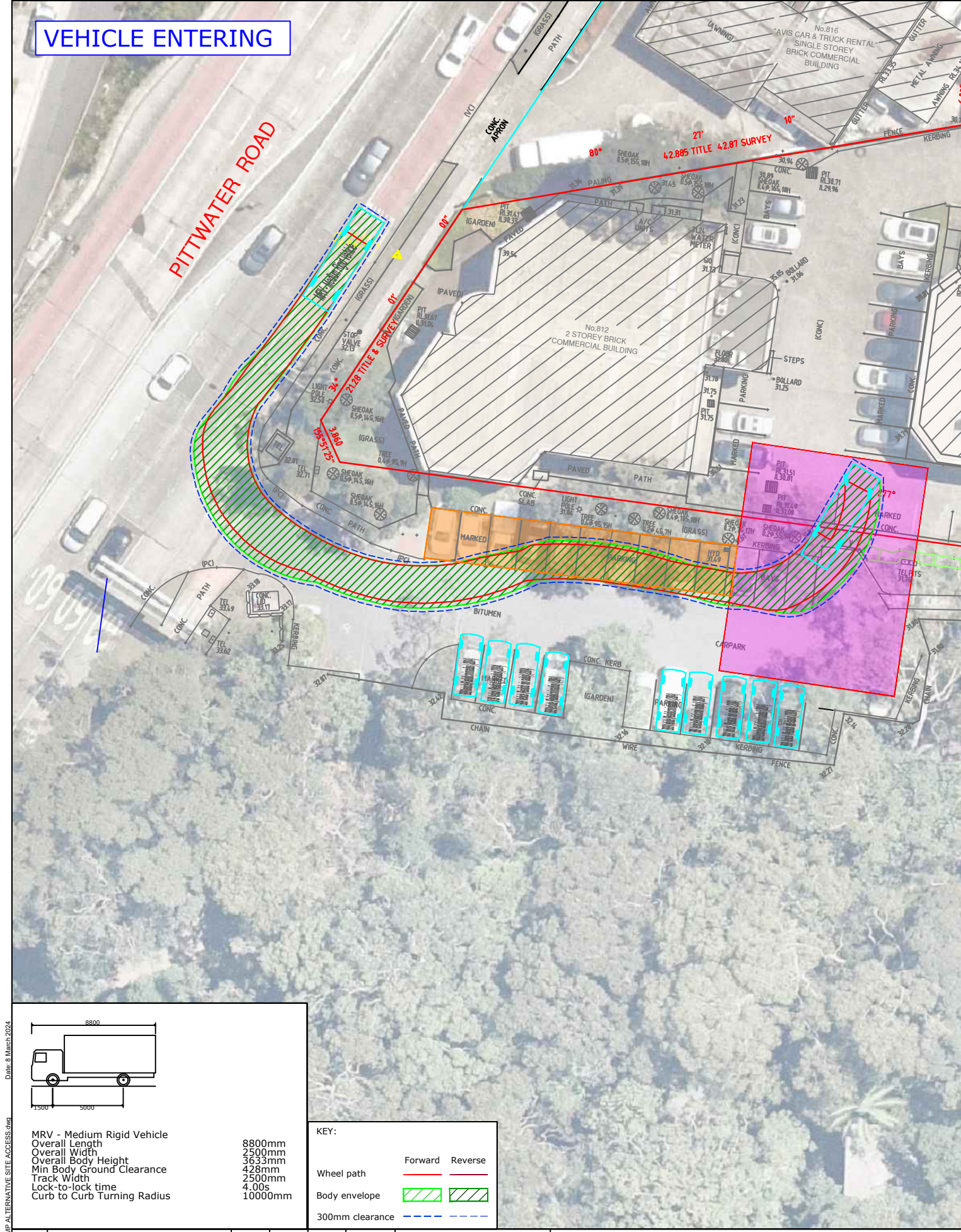

MRV - Medium Rigid Vehicle
 Overall Length 8800mm
 Overall Width 2500mm
 Overall Body Height 3633mm
 Min Body Ground Clearance 428mm
 Track Width 2500mm
 Lock-to-lock time 4.00s
 Curb to Curb Turning Radius 10000mm

KEY:
 Wheel path Forward Reverse
 Body envelope
 300mm clearance

LEGEND

	TRUCK TURNING AREA
	WORK ZONE

REV.	DESCRIPTION	DRAWN	CHECK	APP'D	DATE
A	ISSUE FOR DISCUSSION	HT	PC	KH	07/03/24



PROJECT
4 DELMAR PARADE & 812 PITWATER ROAD, DEE WHY

TITLE
**SWEPT PATH ANALYSIS
 8.8m MEDIUM RIGID VEHICLE - VEHICLE DRIVING THROUGH NORTHERN CAR SPACES**

DWG No. 21205CAD027	
FIGURE (5)	
DATE STAMP 07 MARCH 2024	
PROJECT No. 21205	SCALE 1:400 @A3
REV. B	

Date: 8 March 2024
 Filename: 21205CAD027-240307-CTMP-ALTERNATIVE SITE ACCESS.dwg

VEHICLE ENTERING

VEHICLE EXITING

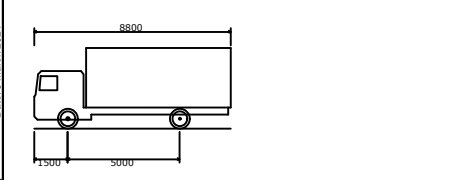
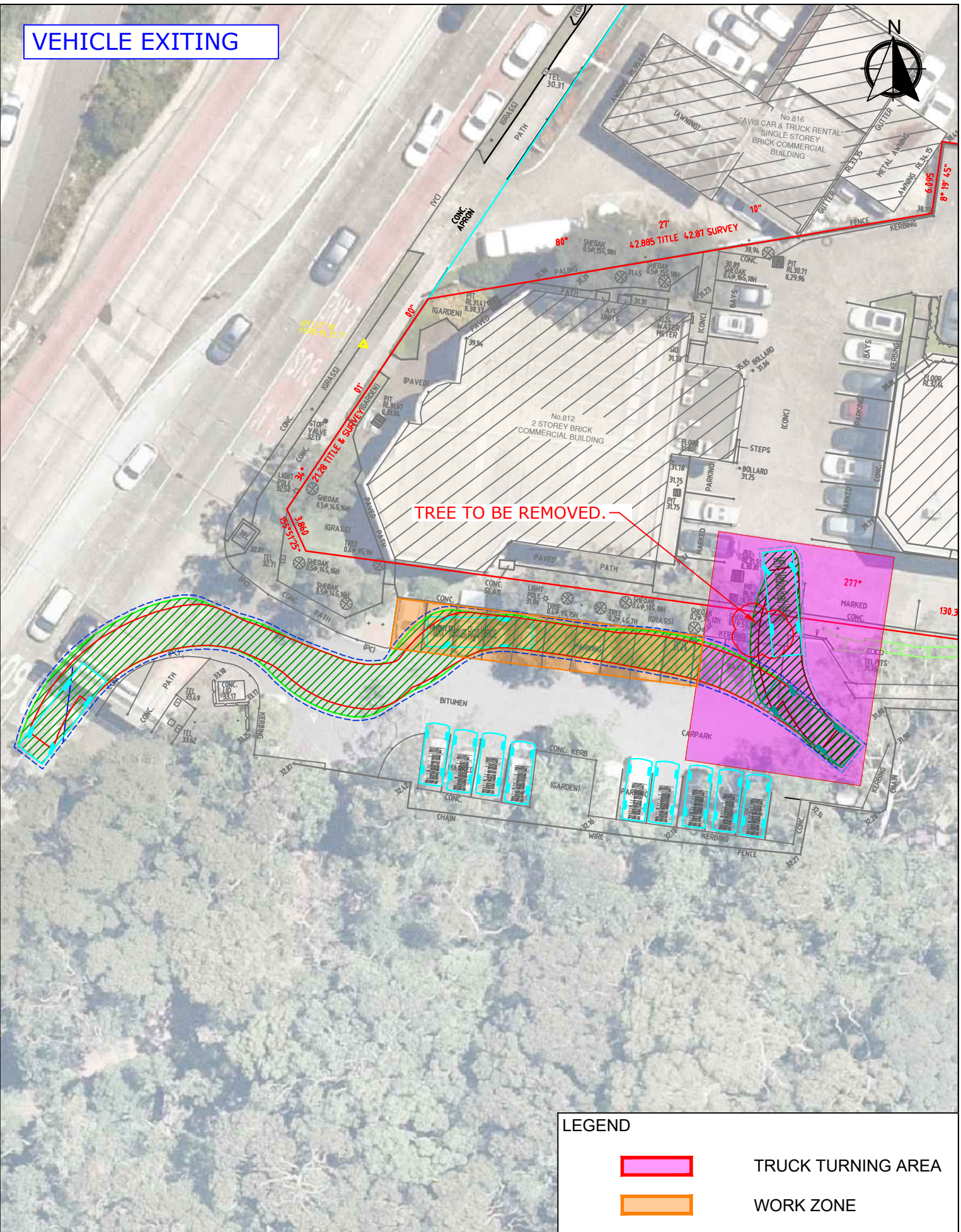
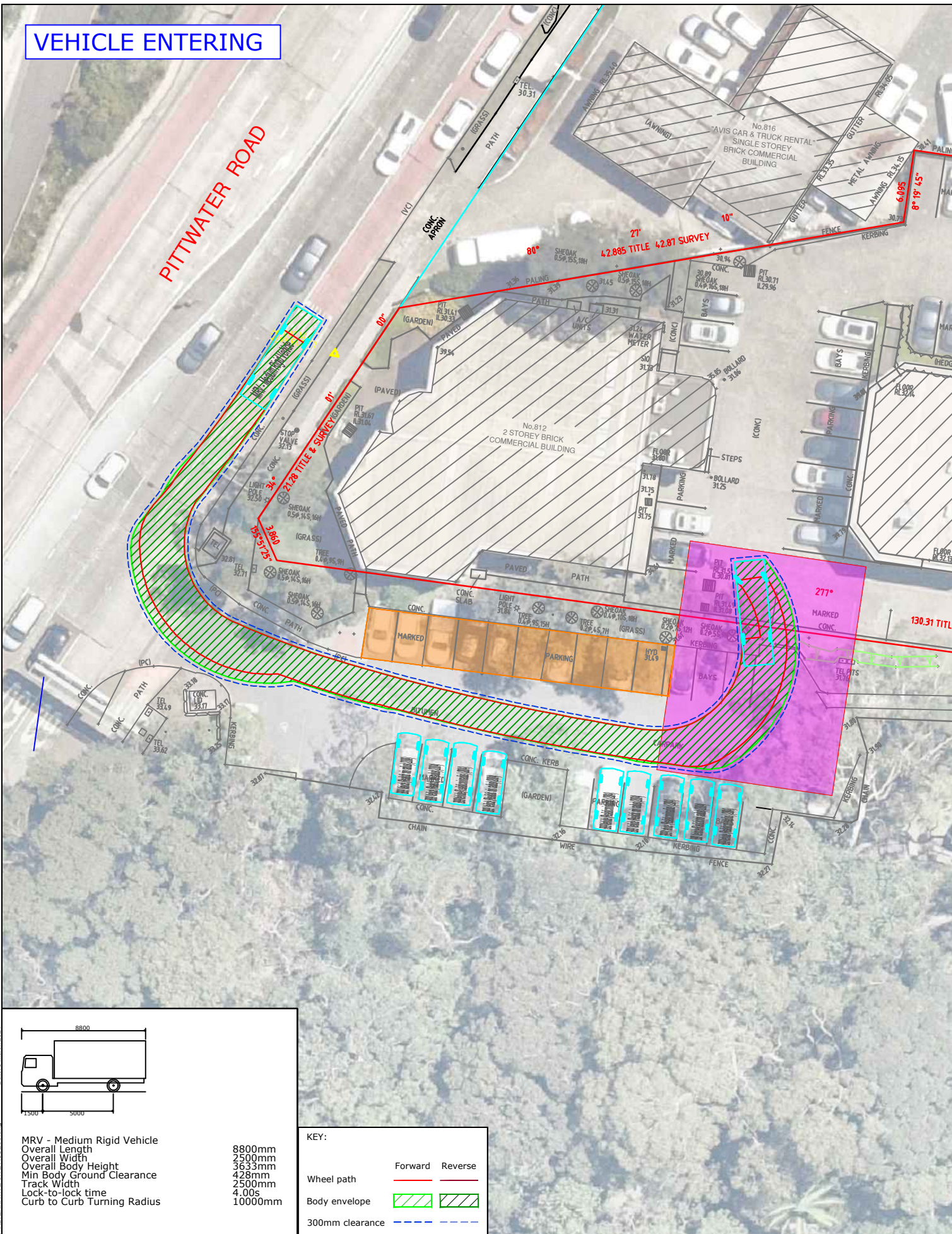

MRV - Medium Rigid Vehicle
 Overall Length 8800mm
 Overall Width 2500mm
 Overall Body Height 3633mm
 Min Body Ground Clearance 428mm
 Track Width 2500mm
 Lock-to-lock time 4.00s
 Curb to Curb Turning Radius 10000mm

KEY:
 Wheel path Forward Reverse
 Body envelope
 300mm clearance

LEGEND	
	TRUCK TURNING AREA
	WORK ZONE

REV.	DESCRIPTION	DRAWN	CHECK	APP'D	DATE
A	ISSUE FOR DISCUSSION	HT	PC	KH	07/03/24



PROJECT
 4 DELMAR PARADE & 812 PITWATER ROAD, DEE WHY

TITLE
 SWEPT PATH ANALYSIS
 8.8m MEDIUM RIGID - VEHICLE DRIVING THROUGH PARKING AISLE

DWG No.	21205CAD027	
	FIGURE (6)	
DATE STAMP	07 MARCH 2024	
PROJECT No.	SCALE	REV.
21205	1:400 @A3	B







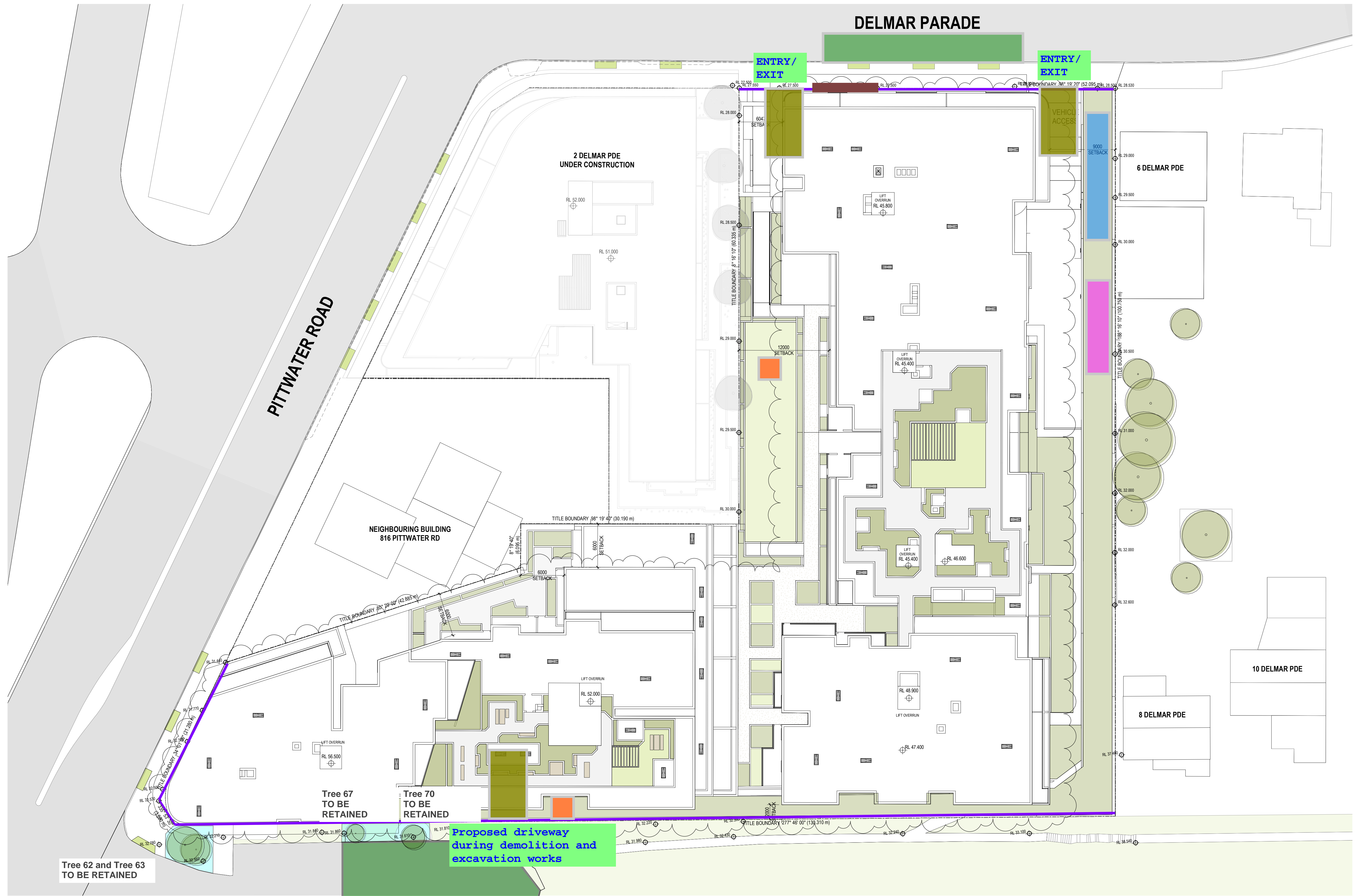

Date: 8 March 2024
 Filename: 21205CAD027-240307-CTMP-ALTERNATIVE SITE ACCESS.dwg

Appendix C

Construction Site Plan



Construction Management Plan - Option B

- | | | | |
|---|---|---|--|
|  | Site Amenities |  | TREE TO BE RETAINED |
|  | Construction Loading / Pumping Zone |  | DEWATERING SYSTEM |
|  | Truck Access during Demolition and Excavation |  | Predestine Access Depending on activity. |
|  | Crane Location |  | Site Fence |

Appendix D

CTMP Approval (dated 1 May 2024)



northern
beaches
council

1 May 2024



Landmark Group Australia Pty Ltd
Level 29 2 Chifley Square
SYDNEY NSW 2000

Our Ref: PERM2023/01609

Dear Sir/Madam,

Implement Traffic Management Plan Permit – Approval Subject to Conditions for 4 Delmar Parade & 812 Pittwater Road DEE WHY NSW 2099

The Transport Network Team have reviewed the submitted Traffic Management Plan (TMP) for the Construction Activities at No.4 Delmar Parade & No.812 Pittwater Road, Dee Why.

This has satisfied the requirement of Condition 16, 20, 53 of DA2022/0145 and is valid for use from 15/02/2024 to 15/04/2026 subject to the conditions outlined in the associated Development Application and Appendix A.

Compliance with the conditions outlined in this letter is required.

You must retain a copy of this letter on site at all times as Council's Officers may require confirmation of approval during routine inspections.

You are required to notify Council as soon as possible should there be any changes in the dates of the proposed work. If you require additional days, you must notify Council in writing no less than two weeks in advance of the permit expiry date. Extension of the permit is subject to Council's consideration.

Should you require further information about this matter please contact Luke Nickson on (02) 8495 6807.

Yours faithfully

Phillip Devon
Manager Transport Network
Transport Network



Appendix A

Conditions

1. TERM

This permit gives the applicant permission to implement the approved CTMP/DTMP only for the days approved and only on the street section(s) nominated on the application or in the CTMP/DTMP.

A separate application for a permit to stand plant is required to stand and operate the plants such as a crane, and concrete pump.

2. PERMIT OPERATIONAL RESTRICTIONS AND HOLD POINTS.

The permit allows the applicant to utilise alternate access plans provided to Council dated 7 March 2024 (Figures 2,3,4,5, and 6).

No access to the site through the Stony Range carpark area is permitted on Tuesdays between 7am and 1pm. No permits will be issued for access from the Stony Range Carpark to the subject site after 1pm on Saturdays.

No access through the Stony Range carpark shall be approved for the Stony Range Spring Fair or any other approved event in the adjoining Gardens.

Once the site demolition and excavation phase has been completed, a review will be undertaken prior to the extension of any work zone or other access arrangement that is in place as part of this agreement.

3. ERECTION OF WARNING SIGNS AND BARRICADES

The applicant must erect traffic control signs and manage traffic in accordance with the approved TGS in the associated CTMP/DTMP at all times and use Roads and Maritime Services (RMS) certified Traffic Controllers to manage traffic at critical locations.

4. TRAFFIC REGULATIONS

Permit holders should note that normal traffic regulations apply to all permits issued. This includes enforcement of clearways during signposted times. Where Traffic is to be stopped at any time an RMS accredited traffic controller or Police must be available to control pedestrian and motor vehicle traffic, in accordance with Australian Standard AS 1742.3 for traffic control.

5. PUBLIC AND SITE SAFETY/ACCESS

All management of pedestrians and vehicles shall comply with the Work Health and Safety Act. Materials and rubbish must not be left on the footpath, roadway or in any way that inconveniences public use of the area. Access for emergency



services and buses must be provided at all times, and all other traffic should only be stopped intermittently to prevent traffic queuing and delays.

6. INDEMNITY AND PUBLIC LIABILITY INSURANCE

The event applicant shall indemnify Northern Beaches Council against all claims for damage or injury that may result from the activity or occupation of part of the public way during the activity. The applicant must provide documentary evidence of public risk insurance cover of at least \$10,000,000 indemnifying Council.

7. TRAFFIC CONTROL PLAN AND/OR PEDESTRIAN CONTROL PLAN

Traffic Control Plan(s) submitted with this application must be prepared and signed off by a suitably qualified and certified person and prepared to the current Australian standards. Pedestrian and vehicle access to private properties shall be maintained at all times. Responsibility for pedestrian and other road users' safety rests with the applicant from the commencement of the installation of traffic control measures until the removal of the traffic control measures. All traffic control plans shall be available on-site at all times.

8. PERMIT PRODUCED ON DEMAND

This permit must be produced on-site at all times if required by an authorised Council officer.

9. CANCELLATION

This permit is subject to cancellation, under the provisions of Section 140 of the Roads Act 1993, at any time if any of the conditions are not complied with.

10. ADVICE

Failure to comply with the terms of this approval constitutes a breach of the Roads Act 1993 and may result in action being taken by Council to remedy the breach. This action may include the issue of a Penalty Infringement Notice or institution of legal action. Additional enforcement action may also be taken under the EP&A Act for a breach of the Consent Conditions.

11. ROAD OCCUPANCY LICENCE

When the plant stands within 100m of traffic signals and/or stands on any State or Regional Road, the Applicant(s) must obtain a Road Occupancy Licence (ROL) and approval from the Roads and Maritime Services (RMS) for the works, which is subject to any conditions specified by the RMS that may impact their road network including approved hours of work.

12. OUT-OF-HOURS PERMIT

The permit hours are 7:00am to 5:00pm, Monday to Friday and 8:00am to 1:00pm on Saturday. To operate outside of these hours you will need to apply for an



additional permit (Out-of-hours Permit). This permit requires approval from Council's Environmental Compliance staff.

13. NOTIFICATION

The affected residents must be notified of the changes in traffic conditions in advance of the works. The notification letter must also provide the contact phone number of the site officer for residents' enquiries. The various emergency services and relevant Bus Companies must be notified of the changes in traffic conditions in advance of the works.

A minimum of five (5) business days written must be given to residents and relevant Bus Companies prior to the implementation of any traffic control.

13. STAFF PARKING

The Site Manager, at the toolbox and induction meetings, shall ensure all workers are encouraged to utilise public transport rather than to attend the site via private vehicles. A public transport information package is to be prepared and made available to all staff. A copy is kept onsite to be produced on request.

NO site staff are to park in the Stony Range Regional Gardens Carpark.

14. STREET PARKING

At no time will parking along the frontage of the site be impeded by vehicles or equipment associated with the site. In any instance where the parking is required to be occupied for construction purposes, the applicant shall be required to submit to Council and have approved the necessary permits.

Staff and contractors must adhere to the parking restrictions along the frontage of the property at all times.

15. STREET SERVICEABILITY

The footpath, property frontage and street on the approach to the site are to be kept clear and in a serviceable state at all times. The Site Manager, at the direction of Council Staff, will be required to undertake remedial works to rectify any defects as deemed by Council Staff. These rectification works are to be undertaken by the developer at no cost to Council.

16. VEHICLE MOVEMENT

Due to heavy traffic congestion throughout the town centre, all heavy vehicle movements must enter the site from the Stony Range carpark and exit the site onto Delmar Parade during the major commuter peak times (8.00AM to 9.30AM and 4.30PM TO 6.00PM).

All heavy vehicle staging is to be outside of the residential streets and must not impede the free flow of traffic in the surrounding road network. Temporary truck



standing and/or queuing locations on Council road or land in the vicinity of the site are not permitted unless approved by Council prior.

All vehicle movements pertaining to the worksite must follow the approved Vehicle Movement Plan and take the shortest route to and from the site via the closest State Road.

17. SPECIAL PERMITS

Unless otherwise specifically approved in writing by Council, all works, processes, storage of materials, loading and unloading associated with the development are to occur entirely on the property. The applicant, owner or builder must also apply for specific permits available from Council. A minimum of forty-eight (48) hours' notice is required for all permits except work zones, which may require additional assessment time.

18. PERMIT FOR ON-STREET MOBILE PLANT

Separate permits are required for each occasion and each piece of equipment. It is the responsibility of the applicant, owner and builder to take whatever steps are necessary to ensure that the use of any equipment does not violate adjoining property owner's rights.

Restrictions apply to the hours of operation and the area of operation for on-street mobile plant equipment (for example cranes, concrete pumps, and cherry pickers).

19. WORKS ZONE AND BARRICADING

Unless otherwise specifically approved in writing by Council, you have not been provided with any permissions to barricade or reserve parking spaces. Existing kerbside restrictions apply. An application must be made to Council for the alteration of existing kerbside restrictions or the provision of a works zone. In relation to the use of the parking spaces in Stony Range carpark, a work zone must be approved where the area is required for the operation of the access routes approved under this permit.

20. HOARDING PERMIT

Permits are required to erect Class A, Class B and Class C hoardings. If an 'A' Class Hoarding is to be placed on Council's property, that section will require a permit for the occupation of Council's property.

21. STORAGE OF BUILDING MATERIALS AND BUILDING WASTE CONTAINERS (SKIPS) ON COUNCIL'S PROPERTY

Permits to utilise Council property for the storage of building materials and building waste containers (skips) are required for each location. Failure to obtain the



relevant permits will result in the building materials or building waste containers (skips) being impounded by Council with no additional notice being given.

22. CONSTRUCTION TRAFFIC MANAGEMENT PLAN / DEMOLITION TRAFFIC MANAGEMENT PLAN (CTMP / DTMP)

All works and construction activities are to be undertaken in accordance with the approved CTMP/DTMP. All controls in the CTMP/ DTMP must be maintained at all times and all traffic management control must be undertaken by personnel having appropriate RMS accreditation. A copy of the approved CTMP/ DTMP is to be kept onsite at all times and made available to the accredited certifier or Council on request.

Should the implementation or effectiveness of the CTMP/DTMP be impacted by surrounding major development not encompassed in the approved CTMP/DTMP, the CTMP/DTMP measures and controls are to be revised accordingly and submitted to Council for approval

23. PUBLIC LIABILITY INSURANCE

A valid Public Liability Insurance must be re-submitted to Council after the expiration of each submitted insurance.

The Transport Planning Partnership
Suite 402 Level 4, 22 Atchison Street
St Leonards NSW 2065

P.O. Box 237
St Leonards NSW 1590

02 8437 7800

info@tpp.net.au

www.tpp.net.au