

CONSTRUCTION CERTIFICATE No 2010/2345

Signature  **Approval Date** 14/12/10
Issued in accordance with the provisions of the Environmental & Assessment Act 1979 under Sections 109C(1)(b) and 109F
Date Application Received 08/12/10

COUNCIL Pittwater

DEVELOPMENT CONSENT NO N0603/10 **APPROVAL DATE** 30/11/10
Name of Certifying Authority Fitzgerald Building Certifiers Pty Ltd
Accreditation No ABC 2
Accredited Certifier Paul Fitzgerald **BPB 0119**
Accreditation Body BUILDING PROFESIONALS BOARD

Applicant Anne-Louise Clacher C/- Iguana Pools
Address PO Box 707, Moorebank NSW 1875
Contact Number 0416 210 208

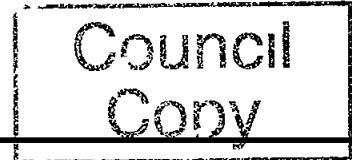

Owner Anne-Louise Clacher
Address 26 North Avalon Rd, Avalon

Subject Land Lot 19 **DP** 8394 **No** 26 **North Avalon Rd, Avalon**

Description of Development – Installation of a fibre glass swimming pool

Building Code of Australia Classification 10b **Value of Work \$** 26 000 00

Builder Details
Name Iguana Pools
Licence Number 219508C
Address 15 Kingston Rd Panania
Contact Number 0416 210 208

Approved Plans And Documents

Plans Prepared By	Drawing Nos	Dated
JF	IG-010, Sheets 1 - 2	16/09/10
Engineer Details	Drawing Nos	Dated
Showers Engineering	05242/PLA	13/09/06

R-294178
\$30 PRVC
17/12/10

IMPORTANT INFORMATION REGARDING POOL FENCES

Recent changes to the swimming pools legislation requires that boundary fencing be constructed as follows

Where any boundary fence is used as part of the swimming pool barrier the boundary fence must be a minimum of 1.8m in height and have a further Non Climb Zone (NCZ) of a minimum 900mm

Note A boundary fence being used as a barrier for entry into a pool area is to be non-climbable from the outside of the pool area. However as noted in Part 2.3.1 of AS 1926.1 - 2007 a non climbable zone may be located on the inside of the fencing. This shall be required to be carried out by the property owner should a boundary fence be made climbable



ABN 63 119 997 590
PO Box 80 Thornleigh NSW 2120
ph 9980 2155 fax 9980 2166 E mail admin@fbcc.com.au

SECTION 1 APPLICATION FORM
APPLICATION FOR CONSTRUCTION/COMPLYING DEVELOPMENT CERTIFICATE
Principle Certifying Authority Agreement
Issued under the Environmental Planning & Assessment Act 1979

Privacy policy – The information you provide in this application will enable your application to be assessed by the certifying authority under the Environmental Planning and Assessment Act 1979. If the information is not provided your application may not be accepted. The application can potentially be viewed by members of the public. Please contact Fitzgerald Building Certifiers if the information you have provided in your application is incorrect or requires modification.

Construction Certificate Complying Development Certificate
Dev Application No N0603/10 Engagement As PCA
Approval Date 30 November 2010 Application for Occupation Certificate

APPLICANT (This Must Be The Owner)

Name IGUANA POOLS
Postal Address PO BOX 707 MOOREBANK NSW 1875
Ph 9822 7755 **FAX** 9601 6760

LAND TO BE DEVELOPED

Address 26 NORTH AVALON ROAD AVALON
Lot 19 **DP** 8394 **Council Area** PITTWATER

DETAILS OF DEVELOPMENT

Description of work INGROUND FIBREGLASS SWIMMING POOL
Estimated Cost of Works \$26 000 00

DETAILS OF BUILDER

Name IGUANA POOLS **License No** 219508C
Address 15 KINGSTON RD PANANIA **Ph No** 0416210208

RECEIVED
- 7 DEC 2010

BY

Section 4 Owners Declaration/Signatures

OWNERS DECLARATION

I, the aforementioned person or authorised representative of a legal entity as described as the Applicant in Section 1 of the Application Form hereby declare the following

- 1 I, to the best of my knowledge, have completed all details in the Application Form in a correct and accurate manner and hereby indemnify Fitzgerald Building Certifiers against any damages, losses or suffering as a result of incorrect information provided under that section**
- 2 I have obtained consent from the owner/s of the property as indicated in the PARTICULARS section to apply and obtain a Construction Certificate Such written consent will be provided with this application**
- 3 I have read, understood and hereby accept the terms and conditions outlined in Section 2 of this form**
- 4 I understand that the Application for a/the Construction Certificate is not complete until all required documentation has been received by Fitzgerald Building Certifiers**
- 5 I understand that the Application for and acquisition of a/the Construction Certificate does not authorise Commencement of Building Work (Refer to appointment of PCA on Fitzgerald Building Certifiers PCA Form)**

As owners of the above mentioned property we consent to this application

As owners of the above mentioned property I/we wish to appoint Paul Fitzgerald as PCA

Owners Signature/s

SEE LETTER OF CONSENT

Date 6/12/2010

Name/s

ANNE LOUISE CLACHER

**Statement of approval to prepare drawings
For the lodgement of
A Development Application or Complying development
Certificate an or a Construction Certificate
and to waiver the cooling off period**

This consent must be signed by all registered property owners

① We ANNE-LOUISE CLACHER
(PRINT FULL NAMES)

Hereby advise that we agree to waiver the cooling off period as set out by the NSW office of Fair Trading Department of commerce Consumer Building Guide regulations page 8/9 and item (7) clause 13 (1) page 12 of the Master Builders Association swimming pool construction contract.

① we are the registered owners of the property known as -
26 NORTH AVALON RD AVALON NSW 2107.
(PRINT FULL RESIDENTIAL ADDRESS)

and ① We consent to _____
proceeding with the immediate preparation of the necessary drawings and the submission of an application to PITTWATER Council for the construction of

On the property know as
26 NORTH AVALON RD AVALON NSW 2107.

① We ANNE-LOUISE CLACHER

Acknowledge that ① We have been advised of the cooling of period referred to above and that we agree to waiver the said cooling off period so that our application can proceed as quickly as possible

ANNE-LOUISE CLACHER
(Signed)

(Signed)

Date 30/8/10

Date _____

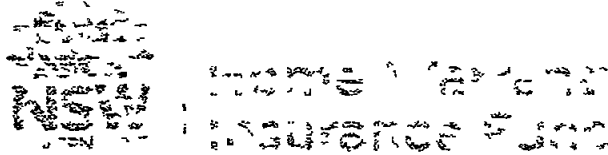

NSWAHHW075720-PermitAuthority

10/09/2010

Iguana Pools Pty Ltd trading as Iguana Pools Pty Ltd
15 Kingston Avenue
PANANIA NSW 2213

Calliden Insurance Ltd
ABN 47 004 125 268 AFS Licence 234438
Level 9 1-33 Exhibition Street
MELBOURNE VIC 3000
Phone (03) 9637 1300 FAX 1300 662 215

Certificate of Insurance

RESIDENTIAL BUILDING WORK BY CONTRACTORS

A contract of insurance complying with sections 92 and 96A of the *Home Building Act 1989* has been issued by **Calliden Insurance Limited** (ABN 47 004 125 268) (AFSL 234438) as agent for and on behalf of the NSW Self Insurance Corporation (SICorp) (ABN 97 369 689 650) who is responsible for management of the Home Warranty Insurance Fund

In respect of:	Swimming Pool
At:	26 North Avalon Road AVALON NSW 2107
Carried out by:	Iguana Pools Pty Ltd trading as Iguana Pools Pty Ltd
Licence Number:	219508C
ABN:	Pending
For:	Anne-Louise Clacher
In the amount of:	\$26 000 00

Subject to the Act and the Home Building Regulation 2004 and the conditions of the insurance contract cover will be provided to

- a beneficiary described in the contract and successors in title to the beneficiary
- OR
- the immediate successor in title to the contractor or developer who did the work and subsequent successors in title

Authorisation Signed by Calliden Insurance Ltd (ABN 47 004 125 268) (AFSL 234438) as agent for and on behalf of the NSW Self Insurance Corporation (SICorp) (ABN 97 369 689 650)

Issued on the 10th day of September 2010

NOTICE To download a copy of your insurance policy wording visit <http://www.policywording.com.au>.

LC
BUIL

See

PAY

Surr
or C

Give

POS

No

Tow

Stat

St George Bank
A Division of Westpac Banking Corporation
Kogarah, 4-16 Montgomery Street, NSW



FORM

date 14/12 RECEIVED

17 DEC 2010

Pay Long Service Levy Board or bearer

the sum of Ninety one dollars

\$ 91

PITFWATER COUNCIL

FITZGERALD BUILDING
CERTIFIERS PTY LTD
119997590

0016993 001120087904820139710

PART B - ADDRESS OF BUILDING/CONSTRUCTION WORK

Number and street 26 North Avalon Rd
Town/suburb Avalon
State NSW Postcode 2107
Estimated start date 20 M 12 Y 2010 Estimated finish date 15 M 04 Y 2011

PART C - DETAILS OF WORK - To be completed by consenting/certifying authority with whom plans lodged for approval

Local Council Area Pitwater
1 DA/CC/CDC No 2010/2345
Estimated value of work (see note on back) \$ 26,000.00 Levy payable \$ 91.00
1 If you have provided a CC above please provide DA number here N0603/10
Name of Officer/Private Certifier Fitzgeralds Business hours phone 99802155

PART D - DETAILS - To be completed by Dept/Authority where applicable - see reverse

Department/Authority
Contract/DA No (circle which) Contract amount \$ 00
Levy payable \$ 00
Contact person (Print) Phone number
Contact person (Signature) Date D M Y

PART E - DECLARATION - To be signed by person liable to pay levy or authorised officer if company/organisation

Any false or misleading information provided on this form may result in prosecution under Section 58A
I hereby declare that the information provided on this form is true and correct to the best of my knowledge
Name Kaycee Signature KC Calose Date 14 M 12 Y 2010

PART F - TO BE COMPLETED WHERE APPLICABLE - SEE REVERSE

Exemption Approval Certificate No

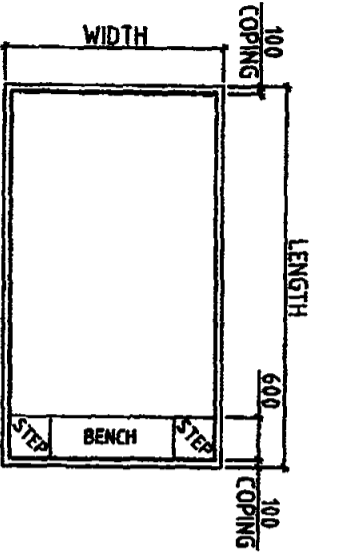

LENGTH	WIDTH	MAX DEPTH	MIN. DEPTH
3.50 m	3.48m	16 m	16 m
4.46 m			
4.98 m			

SECONDARY SUCTIONS WHERE SPA OPERATED TO AS 1838

SPECIFICATIONS:
100mm COPING
DOUBLE SET ENTRY STEPS
MOULDED NON SLIP ON STEPS
CONSTANT DEPTH @ 1600mm
STANDARD POOL SKIMMER BOX
STANDARD POOL RETURNS

BALSA RIBS ON WALLS AT 600 CRS GENERALLY & 400 CRS WHERE POOL WALL IS GREATER THAN 1600 HIGH

BALSA RIBS

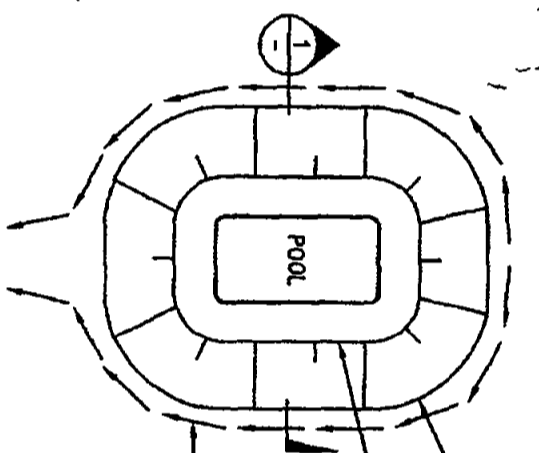
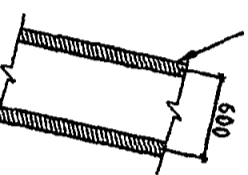

NOTE
ADVISE SHOULD BE SOUGHT FROM QUALIFIED PERSON WHEN PLANTING ANY TREE CLOSER THAN MATURE TREE HEIGHT FROM A POOL IN EXPANSIVE CLAY

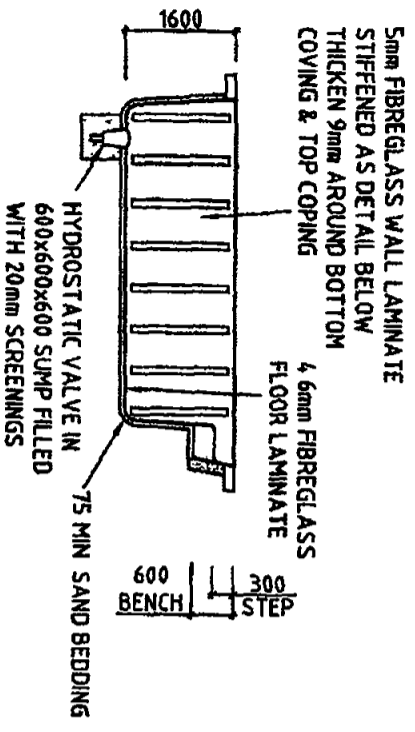

LONGITUDINAL SECTION

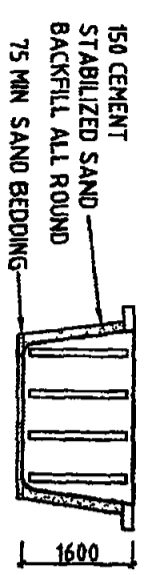

CROSS SECTION

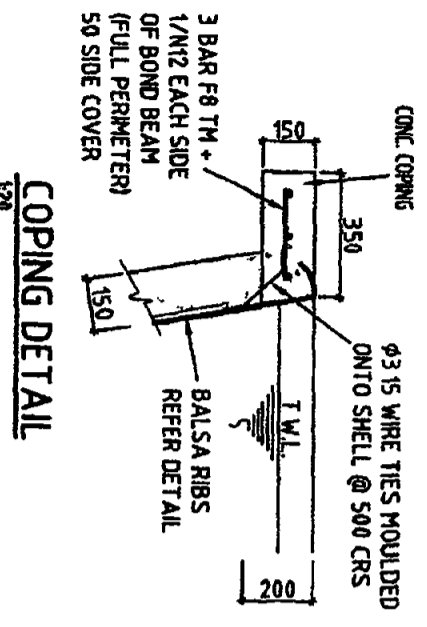

COPING DETAIL

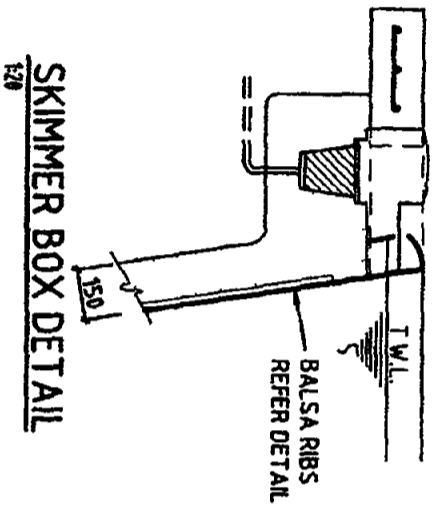

SKIMMER BOX DETAIL

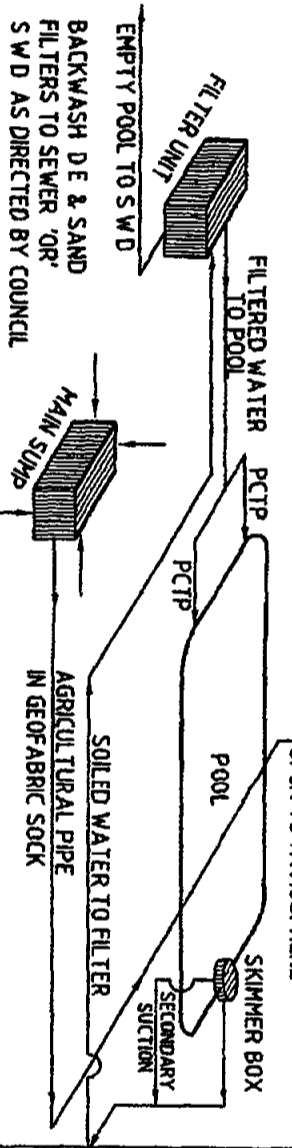

WATER RETICULATION FLOW DIAGRAM

ALL FILTRATION PIPES TO BE 40mm (MIN) PVC CLASS 9 PIPE & ALL FITTINGS CLASS 18 TO AS 14.75

SHOWERS ENGINEERING
Civil & Structural Engineers
Design Inspections Reports

SUITE 9A SOUTH BUILDING
EAST QUAY CORPORATE PARK
34-36 GLENFERRIE DRIVE
ROBINA QLD
OLD

PO BOX 990 ROBINA
QLD 4226 AUSTRALIA
PHONE 07 5578 8088
FAX 07 5578 9429
E MAIL: showen@shoengine.com.au

DATE	SEP '06	DRAWN	DIR/VMM	TITLE	STRUCTURAL DETAILS FIBREGLASS SWIMMING POOL PLATINUM PLUNGE POOL
DESIGNED	RJS	SCALE	AS SHOWN	CLIENT	Leisure Pools 6 COMPUTER ROAD YATALA QLD 4217 PH 07 5587 6366 FAX 07 5587 7866
REVISION	13 06	DATE	31 05	CLIENT	
DRAWING AMENDED	13 06	DATE	31 05	CLIENT	
SIGNED	RJS	DATE	13 06	CLIENT	
SIGNED	RJS	DATE	13 06	CLIENT	

GRP SHELL MANUFACTURE

A THE FIBREGLASS SHELL SHALL BE MANUFACTURED IN ACCORDANCE WITH AS 1838 (PREMOULDED FIBRE REINFORCED PLASTIC SWIMMING POOL'S) MATERIALS:

B MATERIALS:

(a) RESINS SHALL BE TYPE B POLYESTER (UNO)

(b) REINFORCEMENT SHALL BE CLASS E' GLASS FIBRE, MIN GLASS CONTENT OF TOTAL SHELL THICKNESS - 30% BY WEIGHT

C SHELL SHALL BE SPRAY MOULDED WITH

(a) 0.5mm GEL COAT (NPG)

(b) 12 - 15mm BARRIER COAT (VINYL ESTER)

(c) STRUCTURAL LAYER WHICH WILL GIVE TOTAL BARRIER/STRUCTURAL THICKNESS NOMINATED ON DRAWING

(d) 0.2mm FLO COAT

D ALL LAYERS SHALL BE ROLLED OUT TO COMPLETELY BOND REINFORCING & RESINS & EXPEL AIR

E STRUCTURAL LAMINATE SHALL HAVE

(a) FLEXURAL STRENGTH OF 110 MPa

(b) TENSILE STRENGTH OF 60 MPa

(c) MODULUS ELASTICITY OF 6200 MPa

FOUNDATIONS

A POOL HAS BEEN DESIGNED FOR FULLY-IN-GROUND INSTALLATION IF COPING IS GREATER THAN 150 ABOVE SURROUNDING GROUND REFER TO OUT OF GROUND CONSTRUCTION DETAIL. INSTALL SUBDRAINS AS REQ'D IN BATTERS ABOVE POOL TO RELIEVE HYDROSTATIC PRESSURE

B THE POOL IS SUITABLE FOR INSTALLATION IN ROCK, SAND, GRAVEL & SILTY CLAY WHERE POOL IS TO BE INSTALLED IN VERY SOFT CLAY, CATER FOR LATERAL PRESSURE

C ALL TOPSOIL & ORGANIC MATTER UNDER POOL FLOOR IS TO BE REMOVED THE DESIGN REQUIRES THAT THE FOUNDATION MATERIAL IS TO BE UNIFORM SOUND NATURAL GROUND WITH A MINIMUM BEARING CAPACITY OF 50 KPa

D FOR INSTALLATION OF POOL IN EXPANSIVE SOIL REFER EXPANSIVE CLAY PROVISIONS PLAN DETAIL

INSTALLATION

A THE POOL SHALL BE INSTALLED IN ACCORDANCE WITH THE REQUIREMENTS OF AS 1839 & THIS SPECIFICATION

B WALLS SHALL BE BACKFILLED WITH 10:1 SAND CEMENT MIX PLACED AT A RATE TO MATCH POOL FILLING & DAMPENED AFTER COMPLETION

C CONCRETE TO CONCOURSE SHALL BE 20 MPa MIN WITH 20mm AGGREGATE & 80±15 SLUMP - TYPE A CEMENT, COMPACT CONCRETE THOROUGHLY AROUND SKIMMER & UNDER COPING FLANGE

D REINFORCING STEEL

N12 - 12mm DEFORMED BAR TO AS 1838

R#62 - WELDED WIRE FABRIC TO AS 1304

E TOLERANCES SHALL BE IN ACCORDANCE WITH AS 1838

F PLUMBING SHALL BE Ø40 PRESSURE LINES & Ø50 SUCTION LINES CLASS 9 PIPE & CLASS 18 FITTINGS PRIME ALL JOINTS BEFORE APPLYING SOLVENT

OPERATION

A THE POOL SHELL MAY BE DAMAGED IF THE POOL WATER IS DROPPED BELOW NORMAL OPERATING LEVEL CONSULT THE INSTALLATION CONTRACTOR PRIOR TO EMPTYING THE POOL

COC 2010/2345
14.12.10

WASTE MANAGEMENT PLAN

THIS DRAWING DOES NOT FORM PART OF ANY CONTRACT

ALL EXCAVATED MATERIAL TO BE REMOVED FROM SITE
 ALL CONSTRUCTION MATERIAL TO BE REMOVED FROM SITE
 SEDIMENTATION BARRIER TO BE ERRECTED TO PREVENT
 RUN-OFF INTO ADJOINING NEIGHBOURS PROPERTY
 SANDBAGS TO BE USED TO PREVENT RUN-OFF INTO
 STORMWATER SYSTEM

NORTH AVALON RD

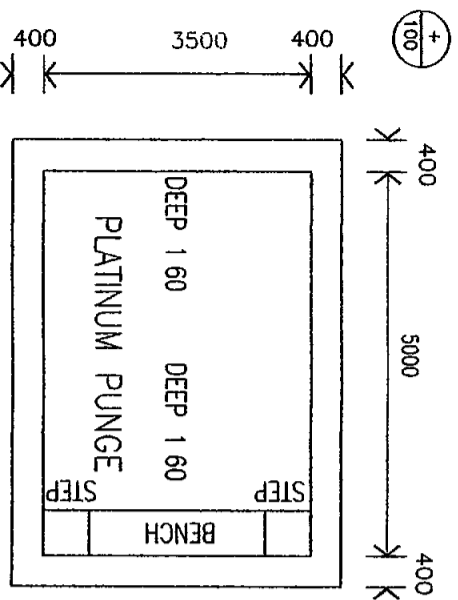

POOL PLAN
 SCALE 1 100

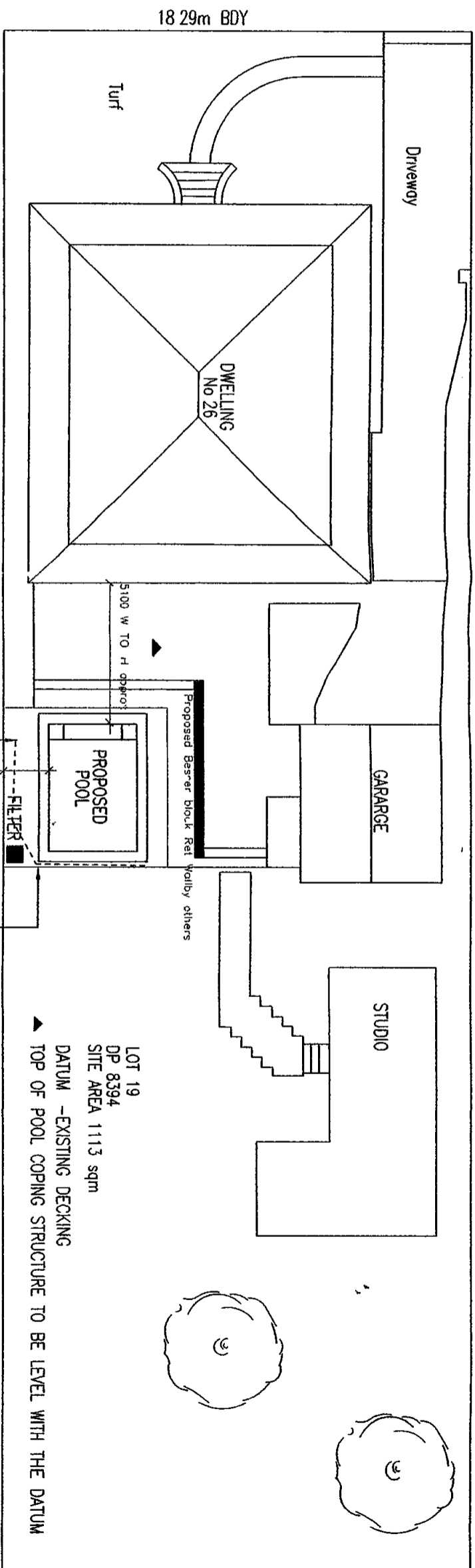

APPROVED DEVELOPMENT CONSENT PLANS
 1200 HIGH CHILD SAFETY FENCE AND SELF CLOSING GATE
 TO COMPLY TO AS1926-86 &
 COUNCIL REQUIREMENTS, by others

CC 2010/2345
 14/12/10

NOTE: THESE PLANS MUST BE READ IN CONJUNCTION WITH THE CONDITIONS OF DEVELOPMENT CONSENT



SWIMMING POOL SITE
 SCALE 1 200

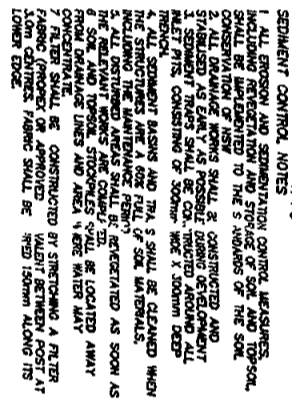

SEDIMENT CONTROL NOTES
 1. ALL EROSION AND SEDIMENTATION CONTROL MEASURES, INCLUDING RETENTION AND STORAGE OF SOIL AND TOP-SOIL, SHALL BE INSTALLED TO THE STANDARDS OF THE SOIL CONSERVATION ACT 1974.
 2. ALL DRAINAGE WORKS SHALL BE CONSTRUCTED AND STABILISED AS EARLY AS POSSIBLE DURING DEVELOPMENT.
 3. ALL DRAINAGE WORKS SHALL BE CONSTRUCTED TO MEET THE REQUIREMENTS OF THE SOIL CONSERVATION ACT 1974.
 4. ALL DRAINAGE WORKS SHALL BE CONSTRUCTED TO MEET THE REQUIREMENTS OF THE SOIL CONSERVATION ACT 1974.
 5. ALL DRAINAGE WORKS SHALL BE CONSTRUCTED TO MEET THE REQUIREMENTS OF THE SOIL CONSERVATION ACT 1974.
 6. ALL DRAINAGE WORKS SHALL BE CONSTRUCTED TO MEET THE REQUIREMENTS OF THE SOIL CONSERVATION ACT 1974.
 7. ALL DRAINAGE WORKS SHALL BE CONSTRUCTED TO MEET THE REQUIREMENTS OF THE SOIL CONSERVATION ACT 1974.
 8. ALL DRAINAGE WORKS SHALL BE CONSTRUCTED TO MEET THE REQUIREMENTS OF THE SOIL CONSERVATION ACT 1974.
 9. ALL DRAINAGE WORKS SHALL BE CONSTRUCTED TO MEET THE REQUIREMENTS OF THE SOIL CONSERVATION ACT 1974.
 10. ALL DRAINAGE WORKS SHALL BE CONSTRUCTED TO MEET THE REQUIREMENTS OF THE SOIL CONSERVATION ACT 1974.

**SHOWERS ENGINEERING
 CIVIL & STRUCTURAL ENGINEER**
 GENERAL DESIGN AND INSTALLATION WITH AS-1838- AND AS-1839
 AND ALL RELEVANT BY LAWS AND REGULATIONS

IGUANA POOLS
 15 KINGSTON AVE, PANANIA
 Phone 0416 210 208 ACN 138 276 605 Burder 1 219508C

PROPOSED FIBREGLASS SWIMMING POOL
 FOR MR & MRS CLACHER
 AT 26 NORTH AVALON RD, AVALON, NSW
 ALL CORRESPONDENCE WHILST PLANS IN COUNCIL AT RING
 APPROVAL TO BILL DUFFY ph 9872-7755 fax 9722-7766

DATE	16/09/10	APPROVED
DRAWN	JF	
SCALE	As Shown	DRAWING No
SHEET	1 OF 1	IG-010

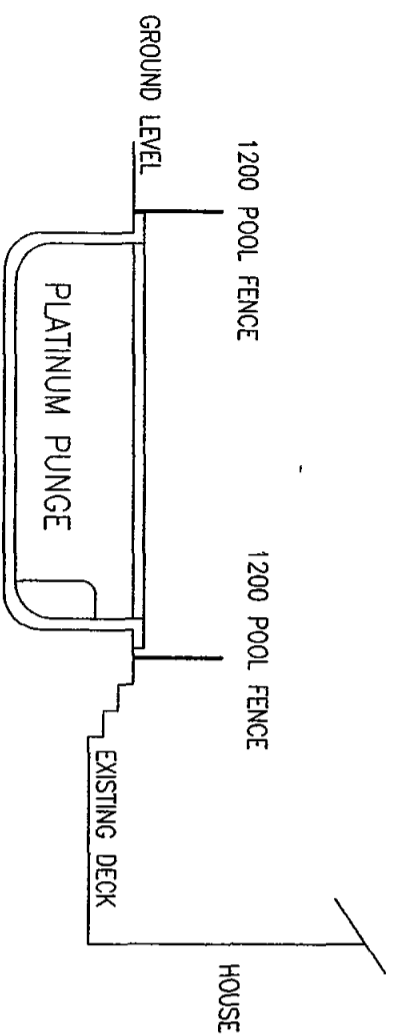

LONGITUDINAL SECTION / ELEVATION
SCALE 1 100

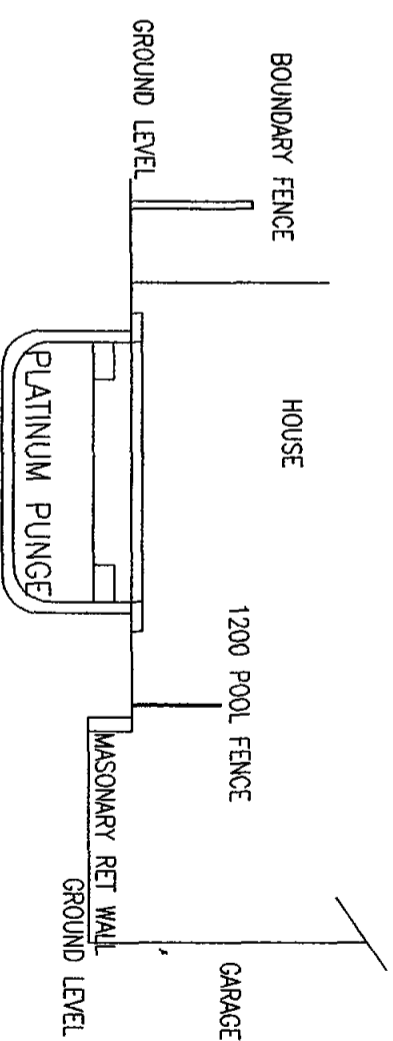

END SECTION / ELEVATION
SCALE 1 100

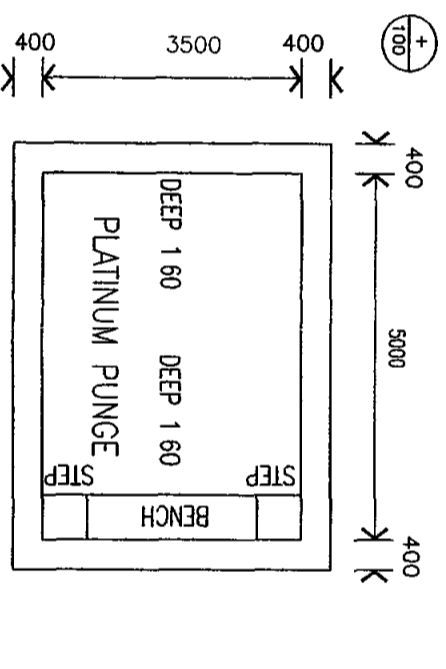

POOL PLAN
SCALE 1 100

pool capacity 25000 litres

APPROVED DEVELOPMENT CONSENT PLANS

NOTE: THESE PLANS MUST BE READ IN CONJUNCTION WITH THE CONDITIONS OF DEVELOPMENT CONSENT

This plan forms part of the approved Certificate as issued by Fitzgerald Building Certifiers Pty Limited

**SHOWERS ENGINEERING
CIVIL & STRUCTURAL ENGINEER**

GENERAL DESIGN AND INSTALLATION WITH AS-1838- AND AS-1839
AND ALL RELEVANT BY LAWS AND REGULATIONS

IGUANA POOLS

15 KINGSTON AVE, PANANIA

Phone 0416 210 208 ACN 138 276 605

Builder Lic^y 219508C

PROPOSED FIBREGLOSS SWIMMING POOL

FOR MR & MRS CLACHER
AT 26 NORTH AVALON RD, AVALON, NSW

ALL CORRESPONDENCE WHILST PLANS IN COUNCIL AWAITING APPROVAL TO BUILD/EC ph 9822-7755 fax 9822-7766

DATE	16/09/10	APPROVED
DRAWN	JF	
SCALE	As Shown	DRAWING NO
SHEET	1 OF 2	IG-010