



28 Lockwood Ave Belrose  
Mixed Use Development

## OPERATIONAL WASTE MANAGEMENT PLAN

24/08/2022  
Report No. SO358  
Revision J

Client

---

**Platinum Property Advisors No 1**

Po Box 765 Ryde NSW  
<https://www.platinumpropertyadvisors.com.au/>

Architect

---

**DKO Architecture**

42 Davies St Surry Hills 2010  
<https://dko.com.au/>  
T 02 8346 4500

**ELEPHANTS FOOT RECYCLING SOLUTIONS • ABN 70 001 378 294**  
44-46 Gibson Ave Padstow NSW 2211  
[www.elephantsfoot.com.au](http://www.elephantsfoot.com.au)

T +612 9780 3500 • F +612 9707 2588  
E [info@elephantsfoot.com.au](mailto:info@elephantsfoot.com.au)

## SCOPE

This waste management plan (WMP) only applies to the **operational** phase of the proposed development; therefore the requirements outlined in this WMP must be implemented during the operational phase of the site and may be subject to review upon further expansion for, and/or changes to the development.

The waste management of the **construction** and **demolition** phases of the development are not addressed in this report. It is EFRS's understanding that a construction and demolition WMP will be completed by a separate party appointed by the developer, and submitted separately to this report. Typically, the head contractor of the site will be responsible for removing all construction-related waste offsite in a manner that meets all authority requirements.

## REVISION REFERENCE

Revision	Date	Prepared by	Reviewed by	Description
A	1/11/2019	H Wilkes	A Armstrong	Draft
B	27/11/2019	H Wilkes	A Armstrong	Amendment
C	2/12/2019	H Wilkes	A Armstrong	Amendment
D	9/12/2019	H Wilkes	A Armstrong	Final
E	1/06/2021	H Wilkes	A Armstrong	Draft Amendment
F	13/08/2021	H Wilkes	A Armstrong	Final Amendment
G	6/09/2021	H Wilkes	A Armstrong	Amendment
H	6/07/2022	H Wilkes	A Armstrong	Draft Amendment For 4.55
I	18/08/2022	H Wilkes	A Armstrong	Draft Amendment For 4.55
J	18/08/2022	H Wilkes	A Armstrong	Final Amendment For 4.55

The information contained in this document produced by Elephants Foot Recycling Solutions (EFRS) is solely for the use of the client identified on the cover sheet for the purpose for which it has been prepared for. EFRS undertakes no duty, nor accepts any responsibility for any third party who may rely upon this document. Reproduction, publication or distribution of this document without written permission from EFRS is strictly prohibited.

## TABLE OF CONTENTS

LIST OF TABLES.....	iv
TABLE OF FIGURES.....	iv
GLOSSARY OF TERMS.....	i
INTRODUCTION .....	2
REPORT CONDITIONS.....	3
DEVELOPMENT SUMMARY .....	4
SITE LOCATION.....	4
NORTHERN BEACHES COUNCIL.....	5
COUNCIL OBJECTIVES.....	5
COUNCIL REQUIREMENTS.....	5
STAKEHOLDER ROLES AND RESPONSIBILITIES.....	6
EDUCATION.....	7
SIGNAGE.....	7
RESIDENTIAL WASTE MANAGEMENT.....	8
ESTIMATED WASTE VOLUMES AND PROVISIONS .....	8
HOUSEHOLD WASTE MANAGEMENT PROCEDURES.....	8
COMMON AREAS .....	9
SOURCE SEPARATION.....	9
GENERAL WASTE (GARBAGE).....	9
RECYCLING .....	9
GREEN WASTE.....	9
BULKY GOODS .....	9
E-WASTE.....	10
CHEMICAL WASTE .....	10
ORGANIC WASTE AND COMPOSTING .....	10
RETAIL WASTE MANAGEMENT .....	11
ESTIMATED WASTE VOLUMES AND PROVISIONS .....	11
RETAIL WASTE MANAGEMENT PROCEDURES.....	11
WASHROOMS .....	12
WASTE OILS .....	12
MANAGEMENT OF SPECIALITY WASTE STREAMS.....	12
MOVEMENT AND TRANSPORTATION OF BINS .....	13
EQUIPMENT SUMMARY .....	13
COLLECTION OF WASTE.....	13
RESIDENTIAL.....	13
RETAIL .....	13
COLLECTION AREA.....	13

**OPERATIONAL WASTE MANAGEMENT PLAN**

WASTE ROOM AREAS ..... 14

    CONSTRUCTION REQUIREMENTS ..... 15

    ADDITIONAL CONSIDERATIONS ..... 15

    VENTILATION ..... 15

USEFUL CONTACTS ..... 16

APPENDICES ..... 17

    APPENDIX A ARCHITECTURAL DRAWING EXCERPTS ..... 17

        APPENDIX A.1 GROUND LEVEL – WASTE FACILITIES ..... 17

        APPENDIX A.2 BASEMENT LEVEL 2 – WASTE FACILITIES..... 18

        APPENDIX A.3 BASEMENT LEVEL 3 – WASTE FACILITIES..... 19

    APPENDIX B PRIMARY WASTE MANAGEMENT PROVISIONS ..... 20

        APPENDIX B.1 TYPICAL BIN SPECIFICATIONS ..... 20

        APPENDIX A.1 SIGNAGE FOR WASTE & RECYCLING BINS ..... 21

        APPENDIX B.2 TYPICAL COLLECTION VEHICLE INFORMATION ..... 22

        APPENDIX A.2 TYPICAL MOTORISED BIN TUG ..... 24

        APPENDIX A.3 TYPICAL SEATED BIN MOVER..... 25

    APPENDIX B SECONDARY WASTE MANAGEMENT PROVISIONS ..... 26

        APPENDIX B.1 TYPICAL WORM FARM SPECIFICATIONS..... 26

        APPENDIX B.2 TYPICAL APARTMENT STYLE COMPOST BINS..... 27

        APPENDIX B.3 ELECTRIC ORGANIC COMPOST BIN..... 28

        APPENDIX B.4 TYPICAL COOKING OIL CONTAINERS ..... 29

        APPENDIX B.5 TYPICAL BACK OF HOUSE BINS FOR RETAIL/COMMERCIAL OPERATIONS 30

**LIST OF TABLES**

Table 1: Stakeholder Roles and Responsibilities..... 6

Table 2: Calculated Waste and Recycling Generation – Residential ..... 8

Table 3: Calculated Waste and Recycling Generation – Retail Tenancies ..... 11

Table 4: Equipment Summary..... 13

Table 5: Waste Room Areas ..... 14

**TABLE OF FIGURES**

Figure 1 - Site Location ..... 4

## GLOSSARY OF TERMS

<b>TERM</b>	<b>DESCRIPTION</b>
<i>Baler</i>	A device that compresses waste into a mould to form bales which may be self-supporting or retained in shape by strapping
<i>Chute</i>	A ventilated, vertical pipe passing from floor to floor of a building with openings as required to connect with hoppers and normally terminating at its lower end at the roof of the central waste room(s)
<i>Chute Discharge</i>	The point at which refuse exits from the refuse chute
<i>Chute Discharge Room</i>	A secure, enclosed area or room housing the discharge and associated equipment for the refuse chute
<i>Collection Area/Point</i>	The identified position or area where garbage or recyclables are actually loaded onto the collection vehicle
<i>Compactor</i>	A machine for compressing waste into disposable or reusable containers
<i>Composter</i>	A container/machine used for composting specific food scraps
<i>Crate</i>	A plastic box used for the collection of recyclable materials
<i>Garbage</i>	All domestic waste (Except recyclables and green waste)
<i>Green Waste</i>	All vegetated organic material such as small branches, leaves and grass clippings, tree and shrub pruning, plants and flowers
<i>Hopper</i>	A fitting into which waste is placed and from which it passes into a chute or directly into a waste container. It consists of a fixed frame and hood unit (the frame) and a hinged or pivoted combined door and receiving unit
<i>L</i>	Litre(s)
<i>Liquid Waste</i>	Non-hazardous liquid waste generated by commercial premises that is supposed to be connected to sewer or collected for treatment and disposal by a liquid waste contractor (including grease trap waste)
<i>LRV</i>	Large rigid vehicle described by AS 2890.2-2002 Parking facilities – Off-street commercial vehicle facilities as heavy rigid vehicle (HRV)
<i>Mobile Garbage Bin(s) (MGB)</i>	A waste container generally constructed of plastic with wheels with a capacity in litres of 120, 240, 360, 660, 1000 or 1100
<i>MRV</i>	Medium rigid vehicle
<i>Putrescible Waste</i>	Component of the waste stream liable to become putrid. Usually breaks down in a landfill to create landfill gases and leachate. Typically applies to food, animal and organic products.
<i>Recycling</i>	Glass bottles and jars – PET, HDPE and PVC plastics; aluminium aerosol and steel cans; milk and juice cartons; soft drink, milk and shampoo containers; paper, cardboard, junk mail, newspapers and magazines
<i>SRV</i>	Small rigid vehicle as in AS 2890.2-2002 Parking facilities – Off-street commercial vehicle facilities, generally incorporating a body width of 2.33

## INTRODUCTION

Elephants Foot Recycling Solutions (EFRS) has been engaged to prepare the following waste management plan for the operational management of waste generated by the mixed use development located at 28 Lockwood Ave Belrose.

Waste management strategies and auditing are a requirement for new developments to provide support for the building design, and promote strong sustainability outcomes for the building. It is EFRS's belief that a successful waste management strategy contains three key objectives:

- i. **Promote responsible source separation*** to reduce the amount of waste that goes to landfill, by implementing convenient and efficient waste management systems
- ii. **Ensure adequate waste provisions and robust procedures*** that will cater for potential changes during the operational phase of the development
- iii. **Compliance*** with all relevant council codes, policies, and guidelines.

To achieve these objectives, this WMP identifies the different waste streams likely to be generated during the operational phase of the development. Associated information includes: how the waste will be handled and disposed of, details of bin sizes/quantities and waste rooms, descriptions of the proposed waste management equipment used and information on waste collection points and frequencies.

It is essential that this waste management plan is integrated into the overall management of the building and clearly communicated to all relevant stakeholders.

## REPORT CONDITIONS

The purpose of this report is to document a Waste Management Plan (WMP) as part of a section 4.55 submission and is supplied by EFRS with the following limitations:

- Drawings, estimates and information contained in this waste management plan have been prepared by analysing the information, plans and documents supplied by the client, and third parties including Council and government information. The assumptions based on the information contained in the WMP is outside the control of EFRS;
- The figures presented in the report are an estimate only – the actual amount of waste generated will be dependent on the occupancy rate of the building/s and waste generation intensity as well as the building managements approach to educating residents and tenants regarding waste management operations and responsibilities;
- The building manager will make adjustments as required based on actual waste volumes (if waste is greater than estimated) and increase the number of bins and collections accordingly;
- The report will not be used to determine or forecast operational costs or prepare any feasibility study or to document any safety or operational procedures;
- The report has been prepared with all due care however no assurance or representation is made that the WMP reflects the actual outcome and EFRS will not be liable to you for plans or outcomes that are not suitable for your purpose, whether as a result of incorrect or unsuitable information or otherwise;
- EFRS offer no warranty or representation of accuracy or reliability of the WMP unless specifically stated;
- Any manual handling equipment recommended should be provided at the recommendation of the appropriate equipment provider who will assess the correct equipment for supply;
- Design of waste management chute equipment and systems must be approved by the supplier.
- EFRS cannot be held accountable for late changes to the design after the WMP has been submitted to Council.
- EFRS will provide specifications and recommendations on bin access and travel paths within the WMP, however it is the architect's responsibility to ensure the architectural drawings meet these provisions.
- EFRS are not required to provide information on collection vehicle head heights, internal manoeuvring and loading requirements. These variables are considered to be within the applicable Traffic Consultants domain.
- Council are subject to changing waste and recycling policies and requirements at their own discretion.

This WMP has only been finalised once the Draft Watermark has been removed. If the Draft Watermark is present, the information in the WMP is not confirmed.

## DEVELOPMENT SUMMARY

The proposed development falls under the LGA of Northern Beaches Council, and consists of:

- Three buildings with 5 levels and 2 basement level
  - 49 residential units in total
    - 19 units in Building A – Core 1
    - 12 units in Building A – Core 2
    - 18 units in Building B
  - 6 retail units with a total GFA of 3322 m<sup>2</sup>

All figures and calculations are based on area schedules as advised by our client and shown on architectural drawings.

## SITE LOCATION

The site is located at 28 Lockwood Ave Belrose, as shown in Figure.1. The site has frontages to Lockwood Ave and Glenrose Place, with vehicle access via Glenrose Place.

Figure 1 - Site Location

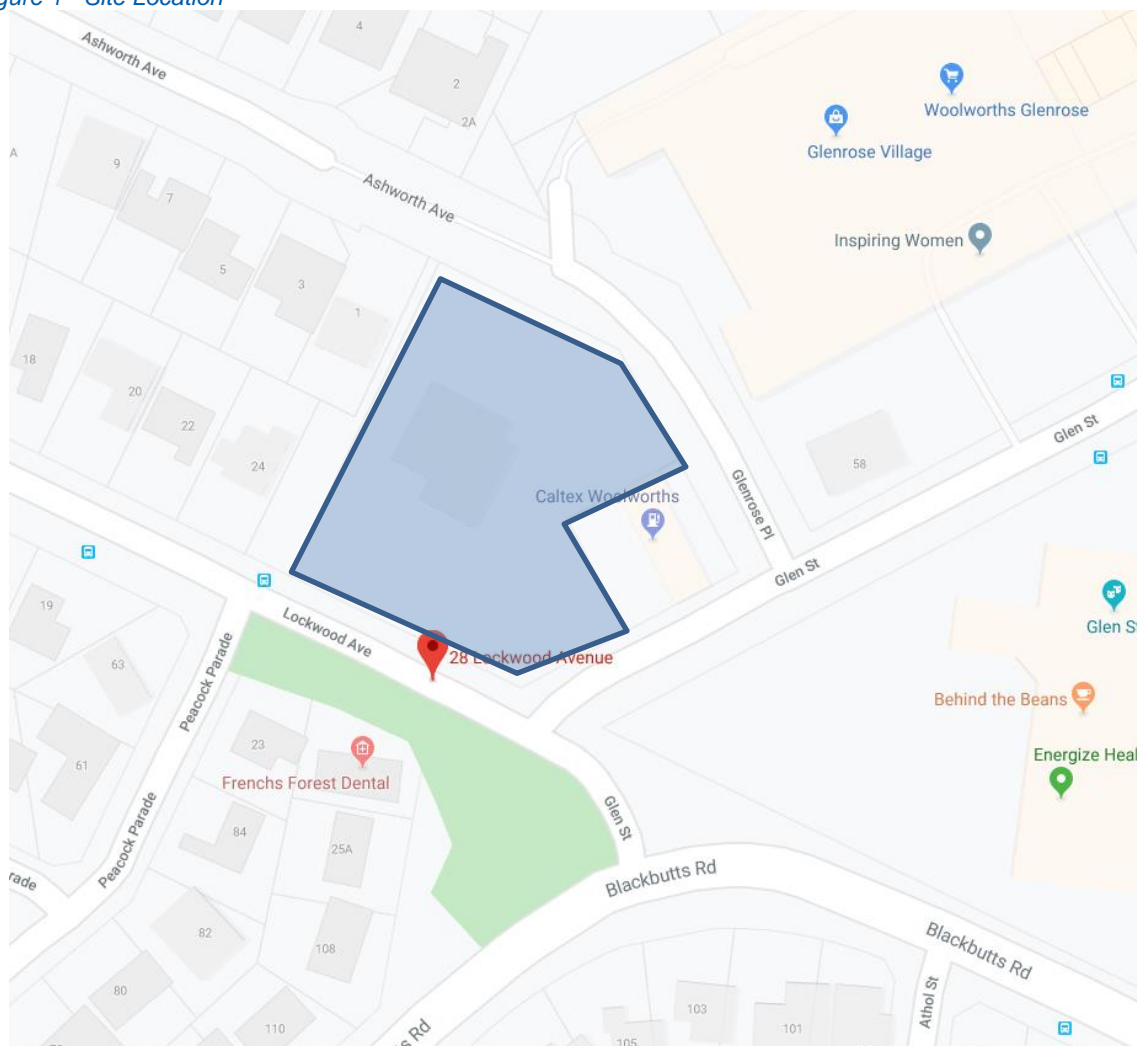



## NORTHERN BEACHES COUNCIL

The development is within Northern Beaches Council's jurisdiction. Northern Beaches Council is the amalgamation of Manly Council, Pittwater Council and Warringah Council.

The garbage and recycling will be guided by the services and acceptance criteria of the Northern Beaches Council. All waste facilities and equipment are to be designed and constructed to be in compliance with the Warringah Council's *Warringah Development Control Plan 2011*, Northern Beaches Council's *Waste Management Guidelines 2016*, Australian Standards and statutory requirements.

### COUNCIL OBJECTIVES

- To facilitate sustainable waste management in a manner consistent with the principles of Ecologically Sustainable Development (ESD).
- To achieve waste avoidance, source separation and recycling of household and industrial/commercial waste.
- To design and locate waste storage and collection facilities which are convenient and easily accessible; safe; hygienic; of an adequate size, and with minimal adverse impacts on residents, surrounding neighbours, and pedestrian and vehicle movements.
- To ensure waste storage and collection facilities complement waste collection and management services, offered by Council and the private service providers and support ongoing control for such standards and services.
- To minimise risks to health and safety associated with handling and disposal of waste and recycled material, and ensure optimum hygiene.
- To minimise any adverse environmental impacts associated with the storage and collection of waste.
- To discourage illegal dumping.

### COUNCIL REQUIREMENTS

**Access** – Ensure waste systems are easy to use and collection vehicles are able to access buildings to safely remove waste and recycling;

**Safety** – Ensure safe practises for storage, handling and collection of waste and recycling;

**Pollution Prevention** – Prevent stormwater pollution that may occur as a result of poor waste storage and management practises;

**Noise Minimisation** – Provide acoustic insulation to the waste service facilities or residential units adjacent to or above chutes, waste storage facilities, chute discharge, waste compaction equipment and waste collection vehicle access points;

**Ecologically Sustainable Development (ESD)** – Promote the principles of ESD through resource recovery and recycling leading to a reduction in the consumption of finite natural resources;

**Hygiene** – Ensure health and amenity for residents, visitors and workers in the Northern Beaches Council.

## STAKEHOLDER ROLES AND RESPONSIBILITIES

The following table demonstrates the primary roles and responsibilities of the respective stakeholders:

*Table 1: Stakeholder Roles and Responsibilities*

Roles	Responsibilities
Strata/Management	<ul style="list-style-type: none"> <li>Ensuring that all waste service providers submit monthly reports on all equipment movements and waste quantities/weights;</li> <li>Organising internal waste audits/visual assessments on a regular basis; and</li> <li>Manage any non-compliances/complaints reported through waste audits.</li> </ul>
Building Manager or Waste Caretaker	<ul style="list-style-type: none"> <li>Ensuring effective signage, communication and education is provided to occupants, tenants and cleaners;</li> <li>Providing staff/contractors with equipment manuals, training, health and safety procedures, risk assessments, and PPE to control hazards associated with all waste management activities;</li> <li>Ensuring site safety for residents, children, visitors, staff and contractors;</li> <li>Abiding by all relevant OH&amp;S legislation, regulations, and guidelines;</li> <li>Assessing any manual handling risks and prepare a manual handling control plan for waste and bin transfers;</li> <li>Preventing storm water pollution by taking necessary precautions (securing bin rooms, preventing overfilling of bins)</li> <li>General maintenance and cleaning of waste rooms on each level;</li> <li>Cleaning and transporting of bins as required;</li> <li>Organising, maintaining and cleaning the general and recycled waste holding area;</li> <li>Organising both garbage and recycled waste pick-ups as required;</li> <li>Organising replacement or maintenance requirements for bins;</li> <li>Organising bulky goods collection when required; and</li> <li>Investigating and ensuring prompt clean-up of illegally dumped waste materials.</li> </ul>
Residents, Tenants and Staff	<ul style="list-style-type: none"> <li>Dispose of all garbage and recycling in the allocated MGBs provided;</li> <li>Ensure adequate separation of garbage and recycling; and</li> <li>Compliance with the provisions of Council and the WMP.</li> </ul>
Waste Contractor	<ul style="list-style-type: none"> <li>Provide a reliable and appropriate waste collection service;</li> <li>Provide feedback to building managers/residents in regards to contamination of recyclables; and</li> <li>Work with building managers to customise waste systems where possible.</li> </ul>
Gardening/Landscaping Contractor	<ul style="list-style-type: none"> <li>Removal of all garden organic waste generated during gardening maintenance activities for recycling at an offsite location.</li> </ul>
Building Contractors	<ul style="list-style-type: none"> <li>Removing all construction related waste offsite in a manner that meets all authority requirements.</li> </ul>

## EDUCATION

Building management is responsible for creating and managing the waste management education process.

Educational material encouraging the correct separation of garbage and recycling items must be provided to each staff member and displayed above any waste receptacles to ensure the correct disposal of waste, including bulky goods (large cardboard, old furniture, large discarded items, etc.) It is recommended that the building caretaker provides information in multiple languages to support correct practises and minimise the possibility of contamination in the collective waste bins.

It is expected that leasing arrangements with retail and commercial operations contain direction on waste management services and expectations.

## SIGNAGE

The building manager is responsible for waste room signage including safety signage (see *APPENDIX A.1*). Appropriate signage must be prominently displayed on doors, walls and above all bins, clearly stating what type of waste or recyclables is to be placed in the bin underneath.

## RESIDENTIAL WASTE MANAGEMENT

The Northern Beaches Council’s *Waste Management Guidelines 2016* has been referenced to calculate the total number of bins required for the residential units. Calculations are based on generic figures; waste generation rates may differ according to the residents’ waste management practice.

### ESTIMATED WASTE VOLUMES AND PROVISIONS

The following table shows the estimated volume (L) of garbage and recycling generated by the residential component of the development. The number of bins is based on the number of bins required for each level of each building core.

*Table 2: Calculated Waste and Recycling Generation – Residential*

Building/ Core	# Units	Garbage Generation Rate (L/unit/week)	Generated Garbage (L/week)	Paper Recycling Generation Rate (L/unit/week)	Generated Paper Recycling (L/week)	Co-Mingled Recycling Generation Rate (L/unit/week)	Generated Co-Mingled Recycling (L/week)
<i>Building A - Core 1</i>	19	80	1520	60	1140	40	760
<i>Building A - Core 2</i>	12	80	960	60	720	40	480
<i>Building B</i>	18	80	1440	60	1080	40	720
<b>TOTAL</b>	<b>49</b>		<b>3920</b>		<b>2940</b>		<b>1960</b>
Equipment and Collections	Garbage Bin Size (L)		240	Recycling Bin Size (L)	240	Recycling Bin Size (L)	240
	Garbage Bins per Week		17.00	Recycling Bins per Week	13.00	Recycling Bins per Week	9.00
	Garbage Collections per Week		1	Recycling Collections per Week	1	Recycling Collections per Week	1
	Total Garbage Bins Required		17	Total Recycling Bins Required	13	Total Recycling Bins Required	9
Waste Rooms			Communal Waste Rooms				

During operation, it is the responsibility of the building manager to monitor the number of bins required for the residential component. Waste and recycling volumes may change according to residents’ attitudes to waste disposal and recycling, building occupancy levels or development’s management. Any requirements for adjusting the capacity of the waste facilities can be achieved by changing the number of bins, the bin sizes or collection frequencies. Building management will be required to negotiate any changes to bins or collections with the collection service provider.

### HOUSEHOLD WASTE MANAGEMENT PROCEDURES

Each building will be provided with a Residential Communal Bin Room. The Communal Bin Room for Building A will be provided on Basement Level 2 and the Communal Bin Room for Building B will be provided on Basement Level 3.

Each Communal Bin Room will 240L MGBs for general waste, paper/cardboard recycling and co-mingled recycling. The residents will be responsible for walking their waste and recycling the Residential Communal Bin Room and placing their waste and recycling into the correct bin.

## OPERATIONAL WASTE MANAGEMENT PLAN

---

The building manager is responsible for monitoring the fullness of the bins and the use of the communal waste rooms and rotating with empty bins as required. The Communal Bin Rooms should be large enough so that bin can be arranged so that all bins are accessible without moving any other bins. Full and spare bins will be kept in the Residential Bin Collection Room.

### COMMON AREAS

The residential common areas including lobbies, amenities and circulation areas will be supplied with suitably branded waste and recycling bins where considered appropriate. The building manager will monitor the fullness of these bins in these bins and empty them into the collection bins in the Residential Communal Bin Room as required.

### SOURCE SEPARATION

Waste avoidance, recovery and reuse of discarded materials and responsible management of hazardous waste are all crucial elements of sustainable development. Effective waste management practices in developments significantly improve environmental, social, and economic outcomes on both a local and regional scale, and should be integrated into the waste management processes.

### GENERAL WASTE (GARBAGE)

Residents will be supplied with a collection area in each unit to deposit garbage and collect recyclable material suitable for one day's storage. This is typically located generally in the kitchen, under bench or similar alternate area. Residents should wrap or bag their garbage; bagged garbage should not exceed 3kg in weight or 35cm x 35cm x 35cm in dimension.

### RECYCLING

**Recycling must not be bagged.** It is recommended that residents use a crate or dedicated bin for collecting recyclables within the allocated residential space provided to ensure correct separation.

### GREEN WASTE

Green waste is not typically generated from multi-unit dwellings other than from surrounding building landscaped areas and is removed by the designated maintenance contractor. In the event that green waste is produced i.e trimming of indoor or balcony plants then this may be disposed of via coordination with the building caretaker or cleaner. Very small quantities may be disposed of via the general waste stream.

### BULKY GOODS

A room or caged area will be made available for the storage of discarded residential bulky items (e.g. whitegoods, furniture, etc.). This room should be located within close proximity of the garbage and recycling bin collection room and must have a minimum doorway width of 1.5m to allow for easy movement of large waste items in and out of the room.

These areas are crucial to prevent residents from illegally dumping bulky waste on the footpath outside Councils scheduled collection times. Regular illegal dumping can attract other dumped waste, generate litter, detract significantly from the quality and appearance of the development and reduce amenity of the street.

Residents will be required to liaise with building management regarding the transportation and disposal of bulky goods. Ideally, bulky waste should be collected on a regular schedule so that

## OPERATIONAL WASTE MANAGEMENT PLAN

---

the storage area does not become overfull and so that residents know when to place items in there for collection. Councils may arrange for more frequent collections of bulky waste for MUDs, however collection frequencies vary among different local government areas.

Donations to charitable organisations should be encouraged. Clean, sound furniture and household goods etc. are highly sought after to provide for the disadvantaged. Donations can be arranged with the assistance of the building manager/waste caretaker.

### E-WASTE

E-waste (electronic waste) refers to any equipment containing printed circuit boards. E-Waste must not be placed in standard garbage or recycling, E-Waste can potentially contaminate soil and surrounding water bodies if not disposed of correctly. The best disposal method for e-waste is recycling through a E-waste service or council.

Disposal or recycling of electronic waste will be organised with the assistance of the building caretaker. Residents and/or the building manager may choose to contact Council to find out about new or existing strategies for the disposal and collection of electronic waste.

### CHEMICAL WASTE

Chemical wastes (e.g. cleaning chemicals, paints, oils solvents) pose detrimental effects to human health and the environment if not disposed of correctly. Chemical wastes should be disposed of at a suitable licensed disposal facility. No liquid wastes or wash down waters should be disposed of via the storm water drainage system.

Residents will need to liaise with the building manager when disposing of their chemical wastes. The building manager will be responsible for arranging the correct disposal of chemical waste. Household Chemical CleanOut events are held at various locations throughout NSW on specified dates throughout the year. Locations and dates are subject to change. It is recommended that the building caretaker confirm these details with their local Council.

### ORGANIC WASTE AND COMPOSTING

Recycling organic waste, such as food scraps and garden materials, dramatically reduces the quantity of waste being diverted to land fill and thus reduces residents' ecological footprint. Compost material can also be returned to the soil as a rich fertilizer and improve plant growth and the overall health of surrounding vegetation.

It is recommended that a space for composting and worm farming is made available for all residents in a communal facility or in small private courtyards (see *APPENDIX B.1*). Composting facilities are to be sited on an unpaved area with soil depth of at least 300mm. Residents may also choose to purchase and install apartment style compost bin where practical and self-manage these systems (see *APPENDIX B.2 and APPENDIX B.3*).

## RETAIL WASTE MANAGEMENT

The NSW EPA’s *Better Practice Guide for Resource Recovery In Residential Developments* has been referenced to calculate the total number of bins required for the retail tenancies. Calculations are based on generic figures; waste generation rates may differ according to the tenants’ waste management practices.

### ESTIMATED WASTE VOLUMES AND PROVISIONS

The following table shows the estimated volume (L) of garbage and recycling generated by the retail tenancies within the development. A seven day operating week has been assumed. It has also been assumed that all retail tenancies will share bins, a waste room and collection service.

For the calculations, the total GFA of the retail tenancies have been divided into thirds to take into account the waste generation of future possible tenancies.

*Table 3: Calculated Waste and Recycling Generation – Retail Tenancies*

Type	NLA (m <sup>2</sup> )	Garbage Generation Rate (L/100m <sup>2</sup> /day)	Generated Garbage (L/week)	Recycling Generation Rate (L/100m <sup>2</sup> /day)	Generated Recycling (L/week)
General Retail - Food Retail	1107.33	150	11627.0	100	7751.3
General Retail - Café	1107.33	100	7751.3	120	9301.6
General Retail - Non-Food Retail	1107.33	50	3875.7	100	7751.3
<b>TOTAL</b>	<b>3321.99</b>		<b>23253.9</b>		<b>24804.2</b>
Collections & Equipment	Bin Size (L)		1100	Bin Size (L)	1100
	Garbage Bins Per Week		22	Recycling Bins Per Week	23
	Total Waste Bins Required for 2 Days		7	Total Recycling Bins Required for 2 Days	7

It is the responsibility of the building manager to monitor the number of bins required for the development. Waste volumes may change according to the development’s management, customer base and retail tenancy attitudes to waste disposal and recycling. The bin numbers and sizes may need to be altered to suit the building operation. Seasonal peak periods i.e. public and school holidays should also be considered.

### RETAIL WASTE MANAGEMENT PROCEDURES

The retail tenancies will share a waste room containing 1100L MGBs for waste and 1100L MGBs for recycling. The retail waste room should be sized to hold a minimum of 2 days’ worth of waste and recycling.

Tenants will be responsible for their own storage of garbage and recycling back of house (BOH) during daily operations. On completion of each trading day or as required, nominated retail staff or cleaners will transport their garbage and recycling to the Retail Waste Room and place garbage and recycling into the appropriate collection bins.

Food handling for food cooked or prepared, served and consumed on site will produce a typical waste composition of food scraps from plates, packaging waste and some plastics. Café or restaurant staff will be responsible for their own BOH waste management.

## OPERATIONAL WASTE MANAGEMENT PLAN

---

Cardboard is a major component of the waste generated by retail tenancies. All cardboard should be flattened (to save bin space), placed in and collected from bulk bins. Whilst cardboard is bulky, it is generally lightweight however it can be contaminated with food or liquid which makes it unsuitable for recycling.

To ensure the proper management and disposal of waste, tenants must be made aware of the following practices:

- All garbage should be bagged and garbage bins should be plastic lined;
- Bagging of recyclables is not permitted;
- All interim waste storage is located BOH during operations;
- Individual recycling programs are recommended for retailers to ensure commingled recycling is correctly separated;
- Any food and beverage tenant will make arrangements for storing used and unused cooking oil in a bunded storage area;
- The operator will organise grease interceptor trap servicing;
- A suitable storage area needs to be provided and effectively bunded for chemicals, pesticides and cleaning products;
- Dry basket arrestors need to be provided to the floor wastes in the food preparation and waste storage areas; and
- All flattened cardboard will be collected and removed to the waste room recycling MGB

### WASHROOMS

Washroom facilities should be supplied with collection bins for paper towels (if used). Sanitary bins for female restroom facilities must also be arranged with an appropriate contractor.

### WASTE OILS

Consideration should be given to the use of cooking oil collection systems. A single service provider may be used to reduce the amount of commercial traffic into the loading bay or around the precinct area. This should be measured against bulk delivery of oils where the same vehicle is used to remove containers of waste cooking oils (see APPENDIX B.4 for Typical Cooking Oil Collection System)

### MANAGEMENT OF SPECIALITY WASTE STREAMS

The building manager is responsible for making arrangements for the disposal and recycling of specialised waste streams with an appropriate contractor. Specialised wastes cannot be placed in general waste as they can have adverse impacts to human health and the environment if disposed of in landfill. Retail and Commercial tenants will need to liaise with the building manager when disposing of specialised waste streams.

Specialised waste streams include:

- Chemical Waste
- Liquid wastes
- Toner cartridges
- Lightbulbs
- eWaste
- Batteries



## MOVEMENT AND TRANSPORTATION OF BINS

The building manager is responsible for the transportation of bins from their designated operational locations to their respective collection area prior to scheduled collection times and returning them once emptied to resume operational use.

Transfer of waste and all bin movements should minimise manual handling. Building management must assess manual handling risks and provide any relevant documentation and training to key personnel. Prior to operation developer should contact a bin-tug, trailer or tractor consultant to provide equipment recommendations.

## EQUIPMENT SUMMARY

*Table 4: Equipment Summary*

Component	Part	Qty	Notes
Equipment	Suitable Bin Moving Equipment	1	(See APPENDIX B for Typical Bin Mover)

## COLLECTION OF WASTE

### RESIDENTIAL

Council will be engaged to collect the waste and recycling in accordance with Council's collection schedule. This report assumes that the residential waste and recycling is collected once weekly.

On collection days, the building manager is responsible for transporting the bins from the Residential Communal Bin Rooms on basement level 2 and Basement 3 to the Residential Bin Holding Area on ground level to await collection. All full residential bins for servicing must be placed in the residential bin holding room prior to 6.00am on the scheduled day of collection as nominated by Council.

Council's waste collection vehicle will park on Lockwood Ave. Waste collection staff will collect the bins directly from the Residential Bin Holding Area via a collect and return arrangement.

After servicing has been completed, the building manager will be responsible for returning the bins to Residential Communal Bin Room to resume operation. .

### RETAIL

A private contractor will be engaged to collect the retail waste and recycling bins to an agreed schedule. This report assumes that the retail waste and recycling will be collected three times weekly or a maximum of two days between collections.

The waste collection vehicle will enter the site from Glenrose Place, and park in the loading bay at basement level 2. Waste collection staff will collect the bins directly from the Retail Waste Room.

### COLLECTION AREA

It is Elephant Foot's understanding that the collection areas have been reviewed by a traffic consultant to confirm the swept paths, load requirements and clearances for waste collections. It must be ensured that that the collection vehicle (and other trucks if required) can enter and exit the building in a forward direction.

## WASTE ROOM AREAS

The Residential Communal Bin Rooms should be large enough to allow the bins in this room to be arranged so that all bins can be accessed without moving any other bins. This is to ensure the safety of the residents using this room and ideal functionality.

The Retail Waste Room must be located directly adjacent to the loading bay. It is recommended that the bins in this room are arranged so that all bin can be access without moving any other bins. Bulk bins become heavy when full, therefore it can be a safety issue if staff must move full bins to access empty bins. The retail bins rooms should be sized to hold two days' worth of waste and recycling bins.

The areas allocated for waste storage and collection areas are detailed in Table 5 below. The areas provided are estimates only. Final areas will depend upon room and bin layouts.

*Table 5: Waste Room Areas*

Level	Waste Room Type	Equipment	Estimated Area (m <sup>2</sup> )
B2	Bulky Goods Waste Storage Room		Minimum 21
B2	Residential Communal Bin Room – Building A	11x 240L MGBs (waste) 8x 240L MGBs (paper & cardboard recycling) 6x 240L MGBs (co-mingled recycling)	>20
B3	Residential Communal Bin Room – Building B	6x 240L MGBs (waste) 5x 240L MGBs (paper & cardboard recycling) 3x 240L MGBs (co-mingled recycling)	>12
B2	Retail Waste Room	<i>Two days' capacity:</i> 7x 1100L MGBs (waste) 7x 1100L MGBs (recycling)	>45
G	Residential Bin Collection Area	17x 240L MGBs (waste) 13 x240L MGBs (paper & cardboard recycling) 9x 240L MGBs (co-mingled recycling)	>31

## CONSTRUCTION REQUIREMENTS

Waste rooms construction must comply with the minimum standards as outlined in the *Warringah Development Control Plan 2011* in order to minimise odours, deter vermin, protect surrounding areas, and make it a user-friendly and safe area.

The *NSW Better practice guide for resource recovery in residential developments* also states that better practice bin storage areas should achieve more than the minimum compliance requirements, which are as follows:

- Ensuring BCA compliance, including ventilation. Where required, ventilation system must comply with *AS1668.4-2012 The use of ventilation and air conditioning in buildings*.
- Ensuring storage areas are well lit (sensor lighting preferred) and have lighting available 24 hours a day.
- Provision of bin washing facilities, including taps for hot and cold water provided through a centralised mixing valve. The taps must be protected from bins and be located where they can be easily accessed even when the area is at bin capacity.
- Floor constructed of concrete at least 75mm thick.
- Floor graded so that any water is directed to a sewer authority approved drainage connection to ensure washing bins and/or waste storage areas do not discharge flow into the stormwater drain.
- Provision of smooth, cleanable and durable floor and wall surfaces that extend up the wall to a height equivalent to any bins held in the area.
- Ensuring ceilings are finished with a smooth-faced non-absorbent material capable of being cleaned.
- All surfaces (walls, ceiling and floors) finished in a light colour.

## ADDITIONAL CONSIDERATIONS

- Waste room floor to be sealed with a two pack epoxy;
- All corners coved and sealed 100mm up, this is to eliminate build-up of dirt;
- Tap height and light switch height of 1.6m;
- Storm water access preventatives (grate);
- All walls painted with light colour and washable paint;
- Equipment electric outlets to be installed 1700mm above floor levels;
- The room must be mechanically ventilated;
- Optional automatic odour and pest control system installed
- If 660L or 1100L bins are utilised, 2 x 820mm (minimum) double-doors should be used;
- All personnel doors are hinged, lockable and self-closing;
- Conform to the building code of Australia, Australian standards and local laws; and
- Childproofing and public/operator safety shall be assessed and ensured

## VENTILATION

Bin enclosures must have their own exhaust ventilation system either;

- Mechanically - exhausting at a rate of 5L/m<sup>2</sup> floor area, with a minimum rate of 100L/s minimum; or
- Naturally - permanent, unobstructed, and opening direct to the external air, not less than one-twentieth (1/20) of the floor area

Mechanical exhaust systems shall comply with AS1668 and not cause any inconvenience, noise or odour problem.

## USEFUL CONTACTS

Elephants Foot Recycling Solutions does not warrant or make representation for goods or services provided by suppliers.

### **NORTHERN BEACHES COUNCIL CUSTOMER SERVICE**

Phone: 1300 434 434

Email: [council@northnbeaches.nsw.gov.au](mailto:council@northnbeaches.nsw.gov.au)

### **SULO MGB** (MGB, Public Place Bins, Tugs and Bin Hitches)

Phone: 1300 364 388

### **CLOSED LOOP** (Organic Dehydrator)=

Phone: 02 9339 9801

### **ELECTRODRIVE** (Bin Mover)

Phone: 1800 333 002

Email: [sales@electrodrive.com.au](mailto:sales@electrodrive.com.au)

### **RUD** (Public Place Bins, Recycling Bins)

Phone: 07 3712 8000

Email: [Info@rud.com.au](mailto:Info@rud.com.au)

### **CAPITAL CITY WASTE SERVICES** (Private Waste Services Provider)

Phone: 02 9399 9999

### **REMONDIS** (Private Waste Services Provider)

Phone: 13 73 73

### **SITA ENVIRONMENTAL** (Private Waste Services Provider)

Phone: 13 13 35

### **NATIONAL ASSOCIATION OF CHARITABLE RECYCLING ORGANISATIONS INC.** (NACRO)

Phone: 03 9429 9884

Email: [information@nacro.org.au](mailto:information@nacro.org.au)

### **PURIFYING SOLUTIONS** (Odour Control)

Phone: 1300 636 877

Email: [sales@purifyingsolutions.com.au](mailto:sales@purifyingsolutions.com.au)

### **MOVEXX** (Bin Movers)

Phone: 1300 763 444

### **AUSCOL** (Recycling Oils & Animal Fats)

Phone: 1800 629 476

### **ELEPHANTS FOOT RECYCLING SOLUTIONS** (Chutes, Compactors and eDiverter Systems)

44 – 46 Gibson Avenue

Padstow NSW 2211

Free call: 1800 025 073

Email: [info@elephantsfoot.com.au](mailto:info@elephantsfoot.com.au)

APPENDICES

APPENDIX A ARCHITECTURAL DRAWING EXCERPTS

APPENDIX A.1 GROUND LEVEL – WASTE FACILITIES

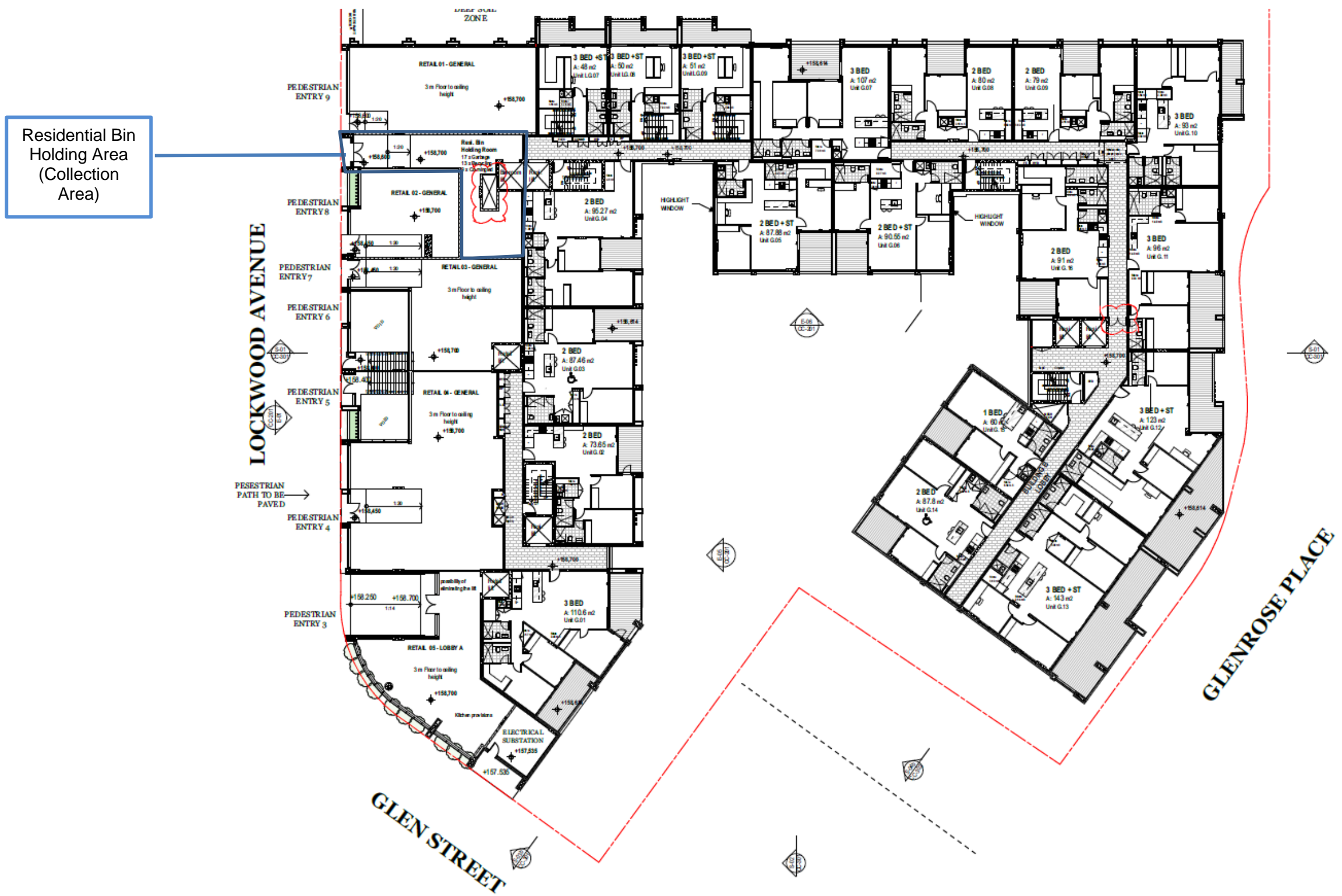

Source: Urbana Corp, 28 Lockwood Ave Belrose, Drawing No DA-105 Rev A, Aug2022– Ground

APPENDIX A.2 BASEMENT LEVEL 2 – WASTE FACILITIES

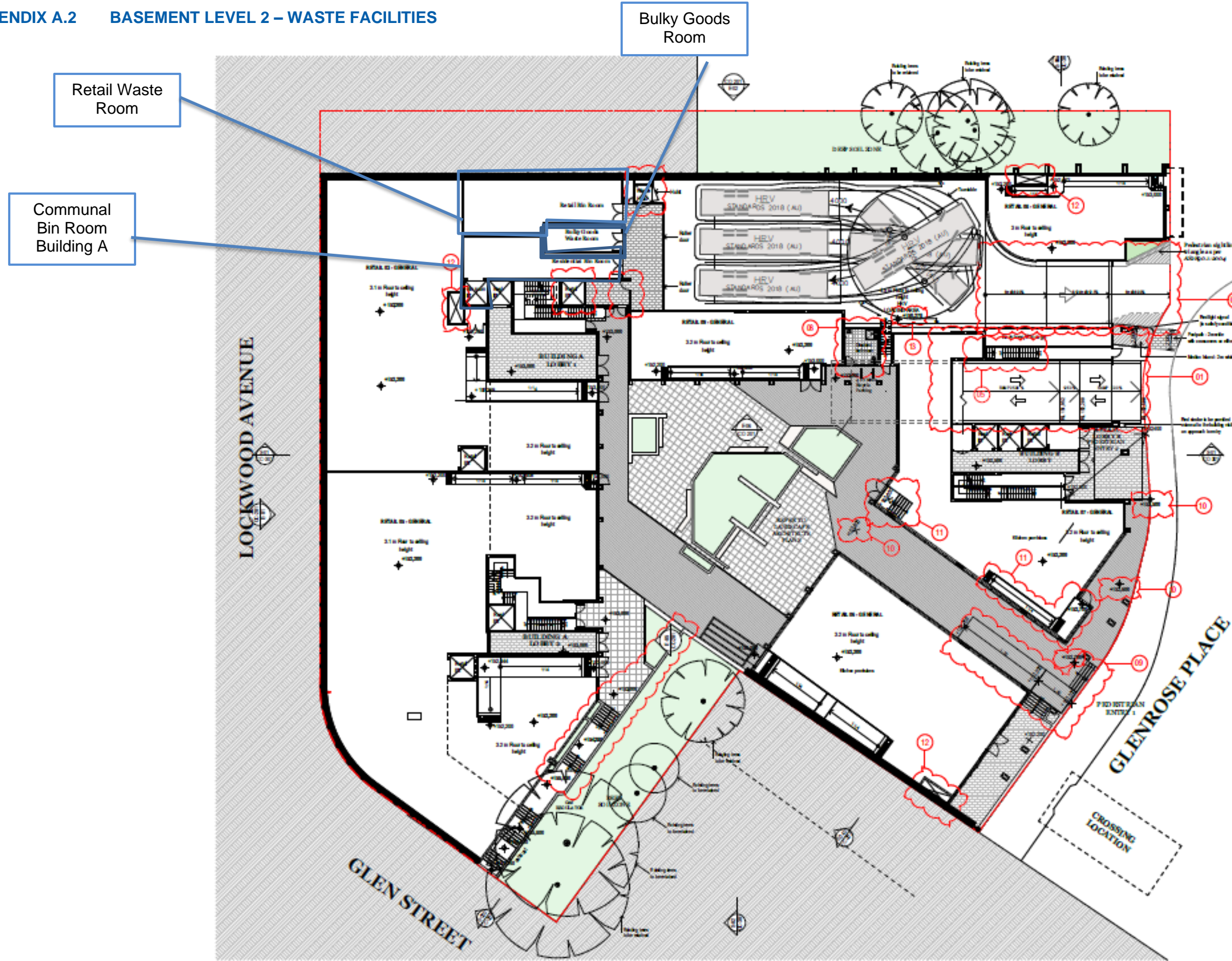

Source: Urbana Corp, 28 Lockwood Ave Belrose, Drawing No DA-103 Rev A, Aug2022– Basement 2

APPENDIX A.3 BASEMENT LEVEL 3 – WASTE FACILITIES



Source: Urbana Corp, 28 Lockwood Ave Belrose, Drawing No DA-102 Rev A, Aug2022– Basement 3

## APPENDIX B PRIMARY WASTE MANAGEMENT PROVISIONS

### APPENDIX B.1 TYPICAL BIN SPECIFICATIONS

The most common bin sizes are provided below, although not all sizes are shown. These dimensions are a guide only and differ slightly between manufacturers.

**Average dimension ranges for two-wheel mobile bins**



Wheelie bin

Bin capacity	80L	120L	140L	240L	360L
Height (mm)	870	940	1065	1080	1100
Depth (mm)	530	530	540	735	820
Width (mm)	450	485	500	580	600
Approximate footprint (m <sup>2</sup> )	0.24	0.26–0.33	0.27-0.33	0.41–0.43	0.49
Approximate weight (kg)	8.5	9.5	10.4	15.5	23
Approximate maximum load (kg)	32	48	56	96	Not known

Sources include Sulo, Single Waste, Cleanaway, SUEZ, just wheelie bins and Perth Waste for two-wheel mobile bins

**Average dimension ranges for four-wheel bulk bins**



Dome or flat lid container

Bin capacity	660L	770L	1100L	1300L	1700L
Height (mm)	1250	1425	1470	1480	1470
Depth (mm)	850	1100	1245	1250	1250
Width (mm)	1370	1370	1370	1770	1770
Approx footprint (m <sup>2</sup> )	0.86–1.16	1.51	1.33–1.74	2.21	2.21
Approx weight (kg)	45	Not known	65	Not known	Not known
Approx maximum load (kg)	310	Not known	440	Not known	Not known

Sources include Sulo, Signal Waste, Cleanaway, SUEZ, Just Wheelie Bins and Perth Waste

**Average dimension ranges for bulk bins over 1700L in capacity**



Bulk bins greater than 1700L

Bin capacity	1m <sup>3</sup>	1.5m <sup>3</sup>	2m <sup>3</sup>	3m <sup>3</sup>	4.5m <sup>3</sup>	6m <sup>3</sup>
Height (mm)	1000	910–1250	865–1000	1020–1580	1440–2014	1650
Depth (mm)	1000	905–1000	1300–1400	1470–1700	1605–1900	1900
Width (mm)	1400	1805–2010	1830–2000	1400–2010	1800–2010	2000
Approximate footprint (m <sup>2</sup> )	1.4	1.63–2.01	2.4–2.8	2.1–3.4	2.9–3.8	3.8

Sources include TORO Waste Equipment, SUEZ, Signal Waste, Perth Waste and ACT Industrial

Source: New South Wales Environmental Protection Authority *Better Practice Guide for Resource Recovery* (2019)



**APPENDIX A.1 SIGNAGE FOR WASTE & RECYCLING BINS**

Waste Signs

Signs for garbage, recycling and organics bins should comply with the standard signs promoted by the EPA (Environmental Protection Authority).

Examples of waste wall posters (EPA supplied)



Examples of bin lid stickers (EPA supplied)



Problem Waste Signs

The EPA has also produced a range of images and signs that can be used for problem wastes, such as fluoro globes and tubes, household and car batteries, e-waste and smoke detectors. To access these resources, contact the NSW EPA. Some examples are shown below.



Safety Signs

The use of safety signs for waste resource recovery rooms must comply with *AS1319 Safety signs for occupational environments*. Safety signs must be used to regulate and control safety related to behaviour, warn of hazards and provide emergency information, including fire protection information. Suitable signs should be decided for each development as required.

Example safety signs



Source: New South Wales Environmental Protection Authority *Better Practice Guide for Resource Recovery* (2019)

**APPENDIX B.2 TYPICAL COLLECTION VEHICLE INFORMATION**

Australian Standards for turning circles for medium and heavy rigid class vehicles

Vehicle class	Overall length (m)	Design width (m)	Design turning radius (m)	Swept circle (m)	Clearance (travel) height (m)
Medium rigid vehicle	8.80	2.5	10.0	21.6	4.5
Heavy rigid vehicle	12.5	2.5	12.5	27.8	4.5

## Collection vehicles

### Large collection vehicles

Waste collection vehicles may be side-loading, rear-loading, front-lift-loading, hook or crane lift trucks. Vehicle dimensions vary by collection service, manufacturer, make and model. It is not possible to provide definitive dimensions, so architects and developers should consult with the local council and/or contractors.

The following characteristics represent typical collection vehicles and are provided for guidance only. Reference to *AS2890.2 Parking facilities: off-street commercial vehicle facilities* for detailed requirements, including vehicle dimensions, is recommended.

Table B2.1: Collection vehicle dimensions

Vehicle type	Rear-loading	Side-loading*	Front-lift-loading	Hook truck	Crane truck
Length overall (m)	10.5	9.6	11.8	10.0	10.0
Width overall (m)	2.5	2.5	2.5	3.0	2.5
Travel height (m)	3.9	3.6	4.8	4.7	3.8
Operational height for loading (m)	3.9	4.2	6.5	3.0	8.75
Vehicle tare weight (t)	13.1	11.8	16.7	13.0	13.0
Maximum payload (t)	10.0	10.8	11.0	14.5	9.5
Turning circle (m)	25.0	21.4	25.0	25.0	18

\* The maximum reach of a side arm is 3 m.

Sources: JJ Richards, SUEZ, MacDonald Johnson, Cleanaway, Garwood, Ros Roca, Bingo and Edbro. Figures shown represent the maximum dimensions for each vehicle type.

### Rear-loading collection vehicles

These vehicles are commonly used for domestic waste collections from MUDs and RFBs and sometimes for recycling. They can be used to collect waste stored in mobile bins or bulk bins, particularly where bins are not presented at the kerbside. They are also used for collecting bulky waste.

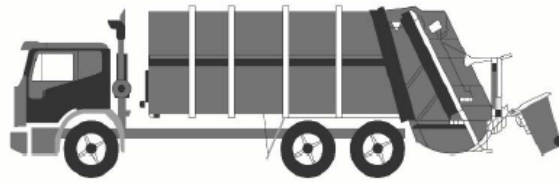

Rear-loading waste collection vehicle

### Side-loading collection vehicles

This is the most commonly used vehicle for domestic waste, recycling and organics collections. It is only suitable for collecting mobile bins up to 360L in capacity.



Side-loading waste collection vehicle

### Front-lift-loading collection vehicles

These vehicles are commonly used for collecting commercial and industrial waste. They can only collect specially designed front-lift bulk bins and not mobile bins.



Front-lift-loading waste collection vehicle

Source: New South Wales Environmental Protection Authority *Better Practice Guide for Resource Recovery* (2019)

## APPENDIX A.2 TYPICAL MOTORISED BIN TUG



### Typical applications:

- Move trolleys, waste bin trailers and 660/1100L bins up and down a ramp incline.
- Quiet, smooth operation with zero emissions and simple to use, no driver's licence required
- Suitable for:
  - High rise building & apartment basements
  - Large factories & warehouse with sloped ground
  - Caravan parks & other large outdoor areas

### Features:

- 1 tonne tow capacity of inclines up to 8 degrees
- 500kg tow capacity if inclines up to 14 degrees
- CE Compliant
- 4.5 km/h max speed
- 2 x 80amp batteries – includes charger
- Powerful transaxle
- Hitch to suit 660L bins

### Safety Features:

- Intuitive paddle lever control
- Stops and repels the unit if activated when reversing.
- Site assessment recommended to assess ramp incline steepness (*See Useful Contacts*)

**OPERATIONAL WASTE MANAGEMENT PLAN**

**APPENDIX A.3 TYPICAL SEATED BIN MOVER**

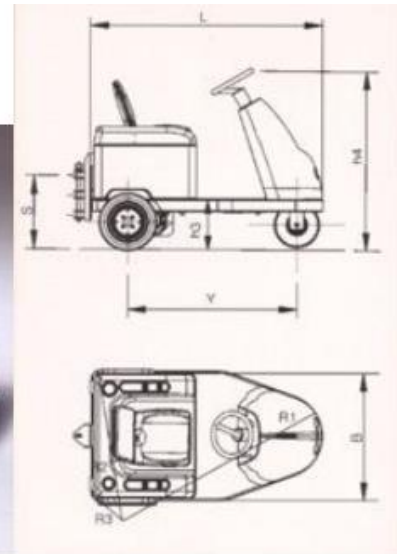

		UNIT M.	BULL 2	BULL 4
Manufacturer	DEC			
Model	BULL			
Platform loading cap.	Nominal capacity	kg	-----	-----
Pull capacity	Pull nominal capacity	kg	2000	4000
Power type	Electric - endothermic		electric	electric
Control type	Standing / seated thiller / steer		seated / steer	seated / steer
Tyres	Pn=pneum. Se=superelastic		Pn	Pn
Wheels	N. front/rear - x drive	n.	1/2X	1/2X
Platform dimensions	L x B (length x width)	mm	-----	-----
Platform height	h6 = unload clearance	mm	-----	-----
Overall dimensions	L = length	mm	1500	1600
	B = width	mm	900	930
	h1 = foot leve	mm	1820	1960
	h3 = Seat height	mm	310	340
	h4 = Steer height	mm	1250	1330
Turning radius	R1 = front min. external	mm	1400	1500
	R2 = rear min. external	mm	1000	1000
	R3 = front min. internal	mm	400	400
Aisle width	A = 180° turn	mm	2200	2300
Tow hook height	s = center from ground	mm	220-350-490	240-380-520

**APPENDIX B SECONDARY WASTE MANAGEMENT PROVISIONS**  
**APPENDIX B.1 TYPICAL WORM FARM SPECIFICATIONS**

Worm farms

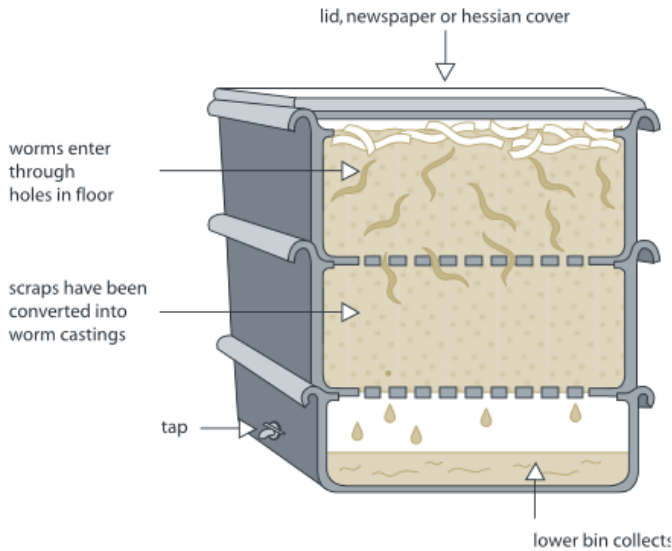

Space requirements for a typical worm farm for an average household:

Height – 300mm per level

Width – 600mm

Length – 900mm

There are many worm farm arrangements. The above dimensions are indicative only.

*SOURCE: Department of Environment and Climate Change NSW 2008, Better Practice Guide for Waste Management in Multi-Unit Dwellings*

## APPENDIX B.2 TYPICAL APARTMENT STYLE COMPOST BINS



Apartment Style Compost bin – available from hardware stores

Suitable for:

- Vegetables
- Coffee grounds and filters
- Tea and tea bags
- Crushed eggshells (but not eggs)
- Nutshells
- Houseplants
- Leaves
- Cardboard rolls, cereal
- Boxes, brown paper bags
- Clean paper
- Shredded newspaper
- Fireplace ashes
- Wood chips, sawdust,
- Toothpicks, burnt matches
- Cotton and wool rags
- Dryer and vacuum cleaner lint
- Hair and fur
- Hay and straw

APPENDIX B.3 ELECTRIC ORGANIC COMPOST BIN

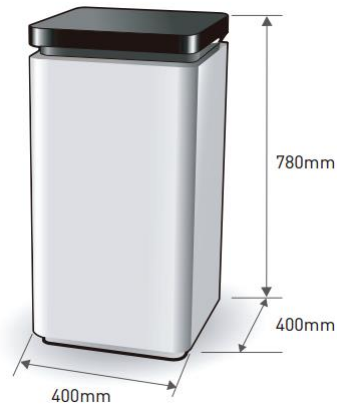

Product Specifications

Decomposition Method	Fermentation by microorganisms
Decomposition Capacity	2 metric tonnes per year* (4 kg per day*)
Rating	220–240 V 50/60 Hz – 1.1 A
Decomposition Time	24 hrs
Operating Temperature	0C and 40C.**
Deodorisation Method	Nano-Filter system
Maximum Power	210 W
Power Usage	Average 1 kwh per day
Weight	21 kgs
External Dimensions	w 400 mm d 400 mm h 780 mm

\* Food Waste Handling Capacity – based on an optimal operating environment.  
 \*\* Ambient temperature range of area where unit may be installed.

SOURCE: Closed Loop Domestic Composter – See Useful Contacts  
<http://www.closedloop.com.au/domestic-composter>



**APPENDIX B.4 TYPICAL COOKING OIL CONTAINERS**

The screenshot displays the AUSCOL website interface. At the top left is the AUSCOL logo with the tagline "A GrainCorp business". To the right is a navigation menu with links for "Home", "About", "Services", "Our Parent Company", and "Contact". Below the navigation is a yellow banner with the text "The RIGHT WAY for Cooking Oil Collection Systems".

The main content area features several product images and descriptions:

- Drums 205L:** An image of a green metal drum with a white lid and a silver drum next to it.
- Pour in Bulk Tank:** An image of a stainless steel bulk tank with a pouring spout.
- Oil Kaddy System:** An image of a white cylindrical tank on a metal cart with a pump and hose.
- Eco Systems:** Two images of white cylindrical tanks on wheels, labeled "Eco System 300 Fixed" and "Eco System 250 mobile".
- Direct-Connect to Fryer:** An image of a white unit with a control panel and a sign that reads "AUSCOL Used Cooking Oil Recycling Station".

On the right side of the page, there is a vertical menu with five items: "Collection Service", "Collection Systems", "Recycling & Environment", "Safety", and "Fresh Oil (WA Only)". The "Collection Systems" item is highlighted in a dark teal color.

APPENDIX B.5 TYPICAL BACK OF HOUSE BINS FOR RETAIL/COMMERCIAL OPERATIONS

