

**LEGEND**

	BOUNDARY
	EXISTING SPOT LEVELS
	PROPOSED SPOT LEVELS
	EXTENT OF NEW WORKS
	ALUMINIUM EDGE
	CONCRETE
	ASPHALT
	MULCH
	TURF
	TREE TO BE RETAINED
	TREE TO BE REMOVED REFER TO ARBORIST REPORT

**EXISTING TREE SCHEDULE**

KEY	BOTANICAL NAME	DBH (mm)	Height (m)	Canopy Spread Radius (m)	Status
1.	CUPRESSUS SEMPERVIRENS	650	18	12	RETAIN
2.	CITHAREXYLUM SPINOSUM	350,350,400	9	6	REMOVE
3.	LOPHOSTEMON CONFERTUS	400	12	9	RETAIN
4.	FICUS BENJAMINA	250	7	8	REMOVE
5.	EUCALYPTUS SALIGNA	850	23	16	REMOVE
6.	EUCALYPTUS SALIGNA	1150	25	18	REMOVE
7.	ARCHONTOPHOENIX CUNNINGHAMIANA	250	6	4	REMOVE
8.	ARCHONTOPHOENIX CUNNINGHAMIANA	250	3	3	REMOVE
9.	ARCHONTOPHOENIX CUNNINGHAMIANA	300	5	4	REMOVE

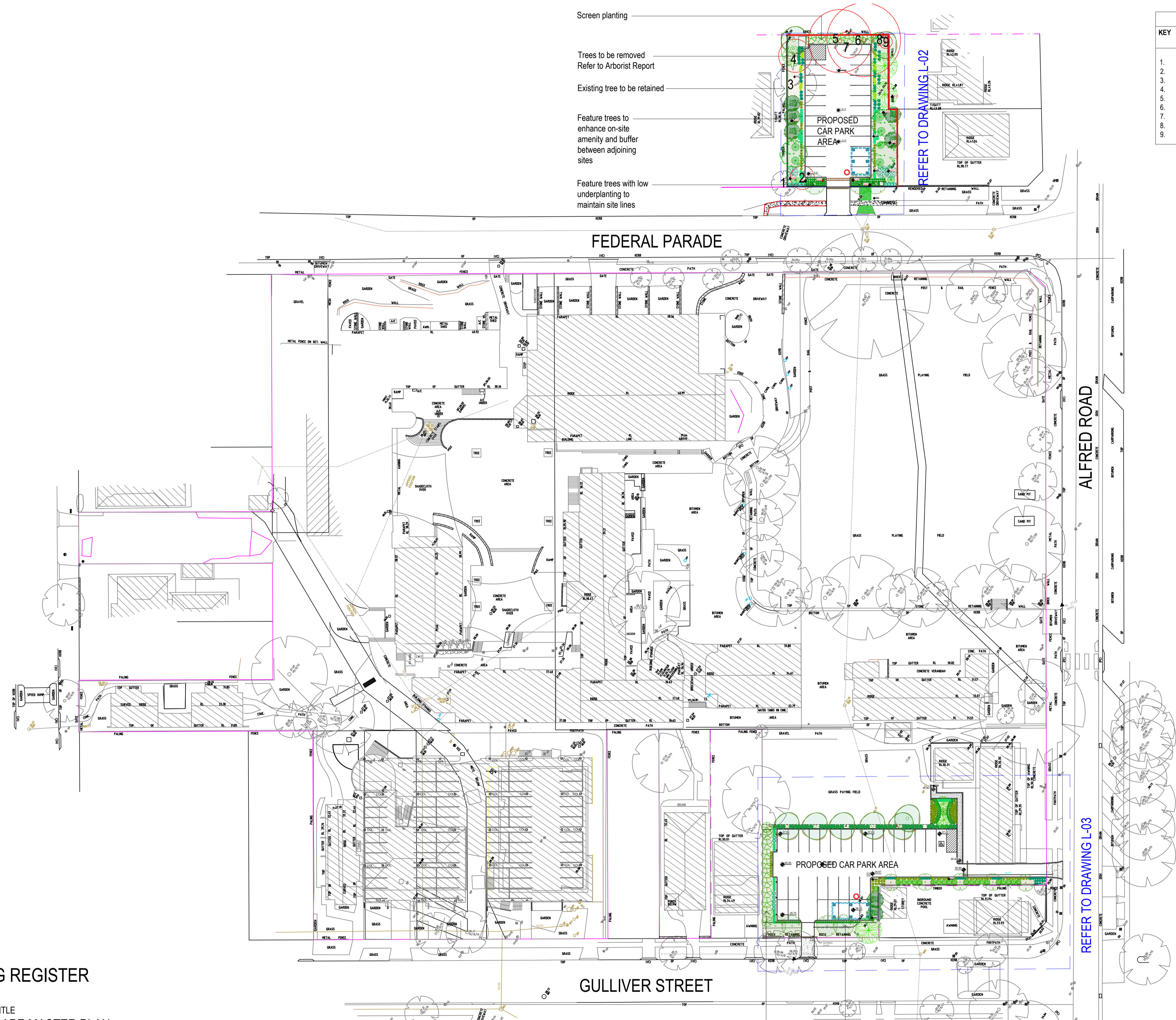

Screen planting

Trees to be removed  
Refer to Arborist Report

Existing tree to be retained

Feature trees to enhance on-site amenity and buffer between adjoining sites

Feature trees with low underplanting to maintain site lines

**LANDSCAPE DESIGN INTENT**

The main objective of the landscape is to provide shade and improve the visual amenity of the car park and streetscape.

Car park trees have been carefully considered and based on their ability to withstand compaction, suitable for their location and have reliable growth and perform well in an urban environment. The selection adheres to the principle of minimising water consumption by the use of low-water native plant species.

In adhering to design principles, consideration has been given to site specific conditions to determine individual tree's placements with underplanting of low grasses to ensure sight lines are maintained upon entering and exiting the car park. Landscape buffers have been provided alongside boundaries that adjoin residential lots.

The design increases the existing tree canopies for the sites providing shade and a more aesthetically pleasing streetscape. The streetscape treatment buffer contains a suitable combination of trees, shrubs and groundcovers to create visual diversity and enhance the streetscape character.

The species selection has been derived from the Northern Beaches Council native species list for Curl Curl Ward.

Water Sensitive Urban Design (WSUD) opportunities have been identified with the recommendation of permeable paving for the car park and pedestrian pathways.

The proposed landscape contributes to the development and will improve the site by providing increased amenities and by adding biodiversity with additional native canopy trees.

**LANDSCAPE DRAWING REGISTER**

DRAWING NO.	DRAWING TITLE
L-01	LANDSCAPE MASTER PLAN
L-02	LANDSCAPE PLAN - SHEET 1
L-03	LANDSCAPE PLAN - SHEET 2
L-04	LANDSCAPE DETAILS & SPECIFICATIONS

Screen planting to provide buffers between adjoining sites

Feature trees to enhance on-site amenity and contribute to the streetscape

Screen planting to provide buffers between adjoining sites

**NOTES**  
 1. Consider to check and verify all dimensions and all levels on site prior to any works.  
 2. Any discrepancies should be immediately referred to Space Landscape Designs.  
 3. All work to comply with all C.A. Statutory Authorities and relevant Australian Standards.  
 4. Consents designed per scope. All measurements are in millimetres.

Rev.	Date	Issue	Checked
A	20/10/21	Preliminary Issue	CW
B	22/10/21	Preliminary Issue	CW
C	09/12/21	DA Issue	CW

Checked  
CW  
CW



Space Landscape Designs Pty Ltd  
 ABN 80 799 663 674 ACN 139 316 251  
 info@spacedesigns.com.au  
 spacedesigns.com.au  
 P 02 9905 7870 F 02 9905 7657  
 Suite 138, 117 Old Pittwater Rd.  
 Brookvale NSW 2100

PROJECT: Proposed Carpark  
 SITE ADDRESS: Federal Parade, Brookvale 2100

CLIENT: St Augustine's College  
 DRN: A.Elboz (A/LDM 625)  
 SCALE: 1:500@A1  
 PROJECT NO: 211930

DRAWING TITLE: LANDSCAPE MASTER PLAN  
 DRAWING NO: L-01  
 Rev: C

**LEGEND**

- BOUNDARY
- EXISTING SPOT LEVELS
- PROPOSED SPOT LEVELS
- EXTENT OF NEW WORKS
- ALUMINIUM EDGE
- CONCRETE
- ASPHALT
- MULCH
- TURF
- TREE TO BE RETAINED

PROPOSED PLANT SCHEDULE					
KEY	BOTANICAL NAME	COMMON NAME	QTY	MATURE HGT	POT SIZE
<b>TREES</b>					
* BC	BACKHOUSIA CITRIODORA	LEMON MYRTLE	3	5m	75Ltr
* CF	CORYMBIA FICIFOLIA 'SUMMER RED'	SUMMER RED	3	5m	75Ltr
* EE	ELAEOCARPUS EUMUNDI	EUMUNDI QUANDONG	3	7m	75Ltr
* ER	ELAEOCARPUS RETICULATUS	BLUEBERRY ASH	5	7m	45Ltr
** TL	TRISTANOPSIS LAURINA	WATER GUM	2	12m	75Ltr
<b>SHRUBS</b>					
* AS	ACMENA SMITHII 'SUBLIME'	SUBLIME LILLY PILLY	8	4m	300mm
** BS	BANKSIA SPINULOSA	HAIRPIN BANKSIA	3	2m	250mm
* CV	CALLISTEMON VIMINALIS 'GREEN JOHN'	GREEN JOHN BOTTLEBRUSH	32	0.8m	200mm
* DE	DORYANTHES EXCELSA	GYMEA LILY	8	2m	250mm
** LL	LEPTOSPERMUM LAEVIGATUM	COASTAL TEA-TREE	1	2m	250mm
** ME	MELALEUCA ERICIFOLIA	SWAMP PAPERBARK	1	4m	200mm
** WF	WESTRINGIA FRUTICOSA	COASTAL ROSEMARY	9	1.5m	200mm
<b>GRASSES / GROUND COVERS</b>					
* DC	DIANELLA CAERULEA 'LITTLE JESS'	LITTLE JESS	39	0.4m	140mm
* LN	LOMANDRA LONGIFOLIA 'NYALLA'	NYALLA	30	0.7m	140mm
* LT	LOMANDRA LONGIFOLIA 'TANIKA'	TANIKA	97	0.5m	140mm
* MP	MYOPORUM PARVIFOLIUM 'YAREENA'	YAREENA	7	0.1m	200mm

\*\*NATIVE SPECIES TO CURL CURL WARD \* NATIVE SPECIES

**PLANTING PALETTE**

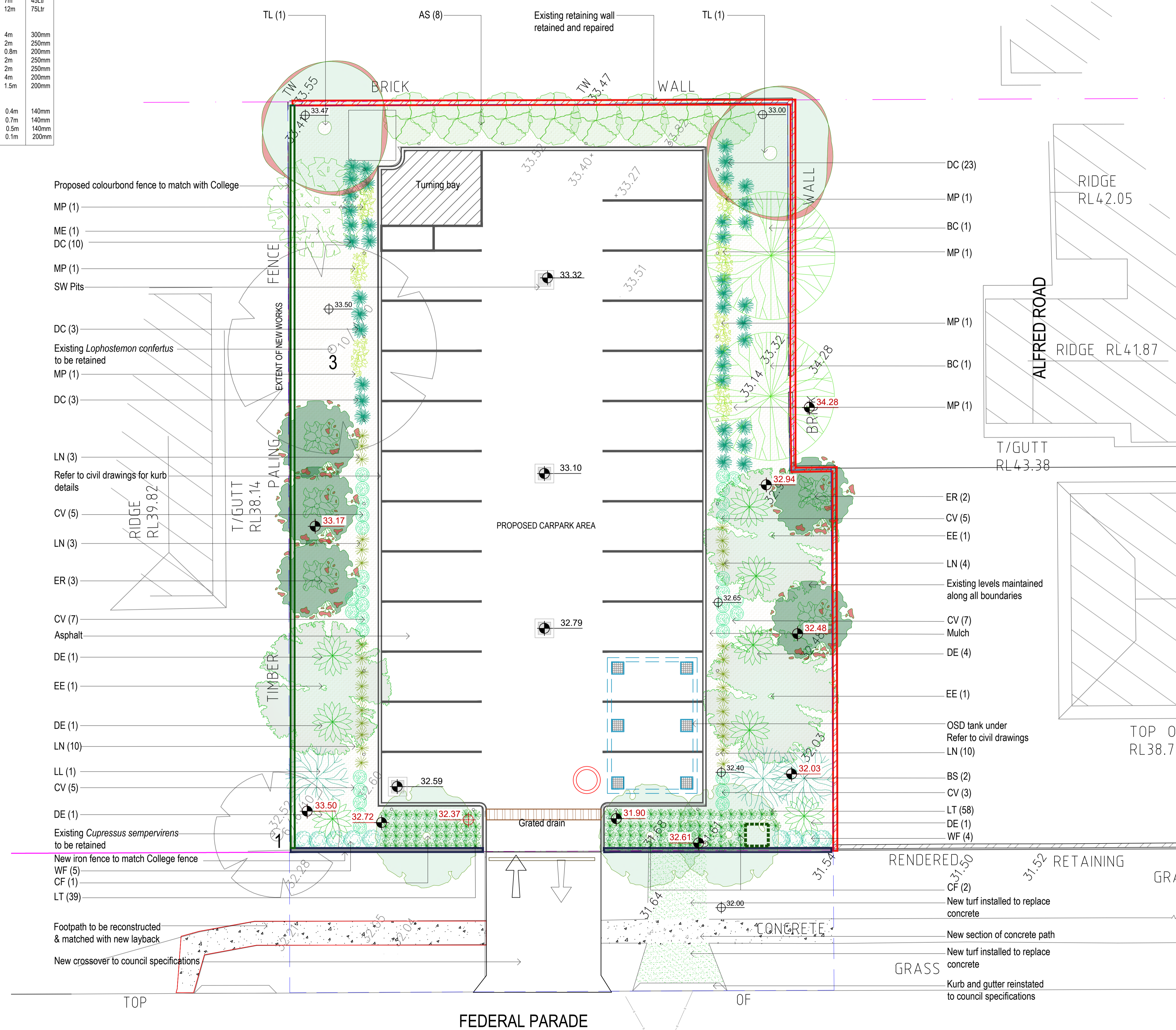
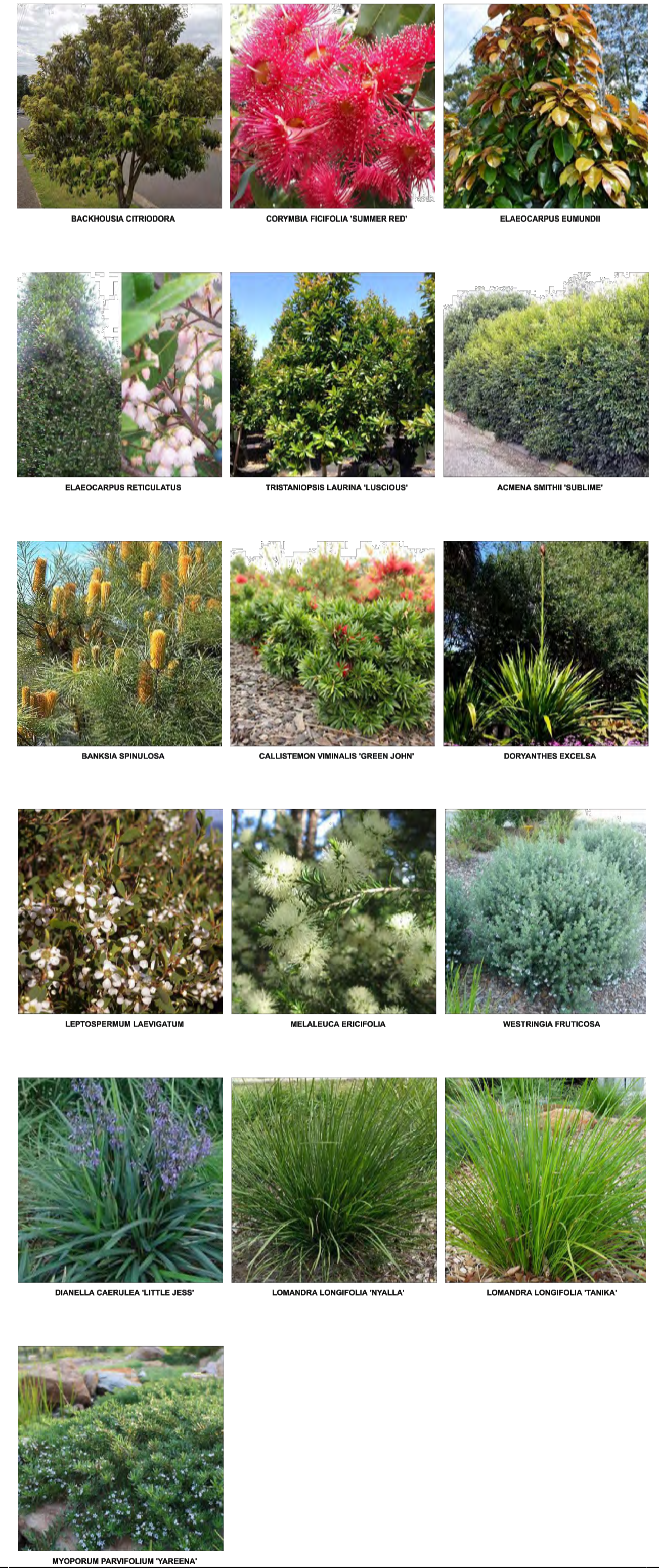

Proposed colourbond fence to match with College  
 MP (1)  
 ME (1)  
 DC (10)  
 MP (1)  
 SW Pits  
 DC (3)  
 Existing *Lophostemon confertus* to be retained  
 MP (1)  
 DC (3)  
 LN (3)  
 Refer to civil drawings for kurb details  
 CV (5)  
 LN (3)  
 ER (3)  
 CV (7)  
 Asphalt  
 DE (1)  
 EE (1)  
 DE (1)  
 LN (10)  
 LL (1)  
 CV (5)  
 DE (1)  
 Existing *Cupressus sempervirens* to be retained  
 WF (5)  
 CF (1)  
 LT (39)  
 Footpath to be reconstructed & matched with new layback  
 New crossover to council specifications

DC (23)  
 MP (1)  
 BC (1)  
 MP (1)  
 MP (1)  
 BC (1)  
 MP (1)  
 ER (2)  
 CV (5)  
 EE (1)  
 LN (4)  
 Existing levels maintained along all boundaries  
 CV (7)  
 Mulch  
 DE (4)  
 EE (1)  
 OSD tank under Refer to civil drawings  
 LN (10)  
 BS (2)  
 CV (3)  
 LT (58)  
 DE (1)  
 WF (4)  
 RENDERED  
 CF (2)  
 New turf installed to replace concrete  
 New section of concrete path  
 New turf installed to replace concrete  
 GRASS  
 Kurb and gutter reinstated to council specifications

**LEGEND**

- BOUNDARY
- EXISTING SPOT LEVELS
- PROPOSED SPOT LEVELS
- EXTENT OF NEW WORKS
- ALUMINIUM EDGE
- CONCRETE
- ASPHALT
- MULCH
- TURF
- TREE TO BE RETAINED

PROPOSED PLANT SCHEDULE						
KEY	BOTANICAL NAME	COMMON NAME	QTY	MATURE HGT	POT SIZE	
<b>TREES</b>						
BC	BACKHOUSIA CITRIODORA	LEMON MYRTLE	1	5m	75Ltr	
CF	CORYMBIA FICIFOLIA 'SUMMER RED'	SUMMER RED	4	5m	75Ltr	
ER	ELAEOCARPUS RETICULATUS	BLUEBERRY ASH	2	7m	45Ltr	
HF	HYMENOSPORUM FLAVUM	NATIVE FRANGIPANI	2	8m	75Ltr	
TL	TRISTANIOPSIS LAURINA 'LUSCIOUS'	LUSCIOUS WATER GUM	6	8m	75Ltr	
WS	WATERHOUSIA FLORIBUNDA 'SWEEPER'	SWEEPER	5	9m	45Ltr	
<b>SHRUBS</b>						
AS	ACHENA SMITHI 'SUBLIME'	SUBLIME LILLY PILLY	11	4m	300mm	
CA	CALLISTEMON VIMINALIS 'RED ALERT'	RED ALERT BOTTLEBRUSH	21	2m	200mm	
CV	CALLISTEMON VIMINALIS 'GREEN JOHN'	GREEN JOHN BOTTLEBRUSH	21	0.8m	200mm	
DE	DORYANTHES EXCELSA	GYMEA LILY	1	2m	250mm	
WF	WESTRINGIA FRUTICOSA 'AUSSIE BOX'	AUSSIE BOX WESTRINGIA	37	0.8m	250mm	
<b>GRASSES / GROUND COVERS</b>						
DC	DIANELLA CAERULEA 'LITTLE JESS'	LITTLE JESS	36	0.4m	140mm	
DT	DIANELLA TASMANICA 'WYEENA'	WYEENA	7	0.9m	140mm	
LN	LOMANDRA LONGIFOLIA 'NYALLA'	NYALLA	64	0.7m	140mm	
LT	LOMANDRA LONGIFOLIA 'TANIKA'	TANIKA	88	0.5m	140mm	
MP	MYOPORUM PARVIFOLIUM 'YAREENA'	YAREENA	20	0.1m	200mm	

\*NATIVE SPECIES TO CURL CURL WARD \*NATIVE SPECIES

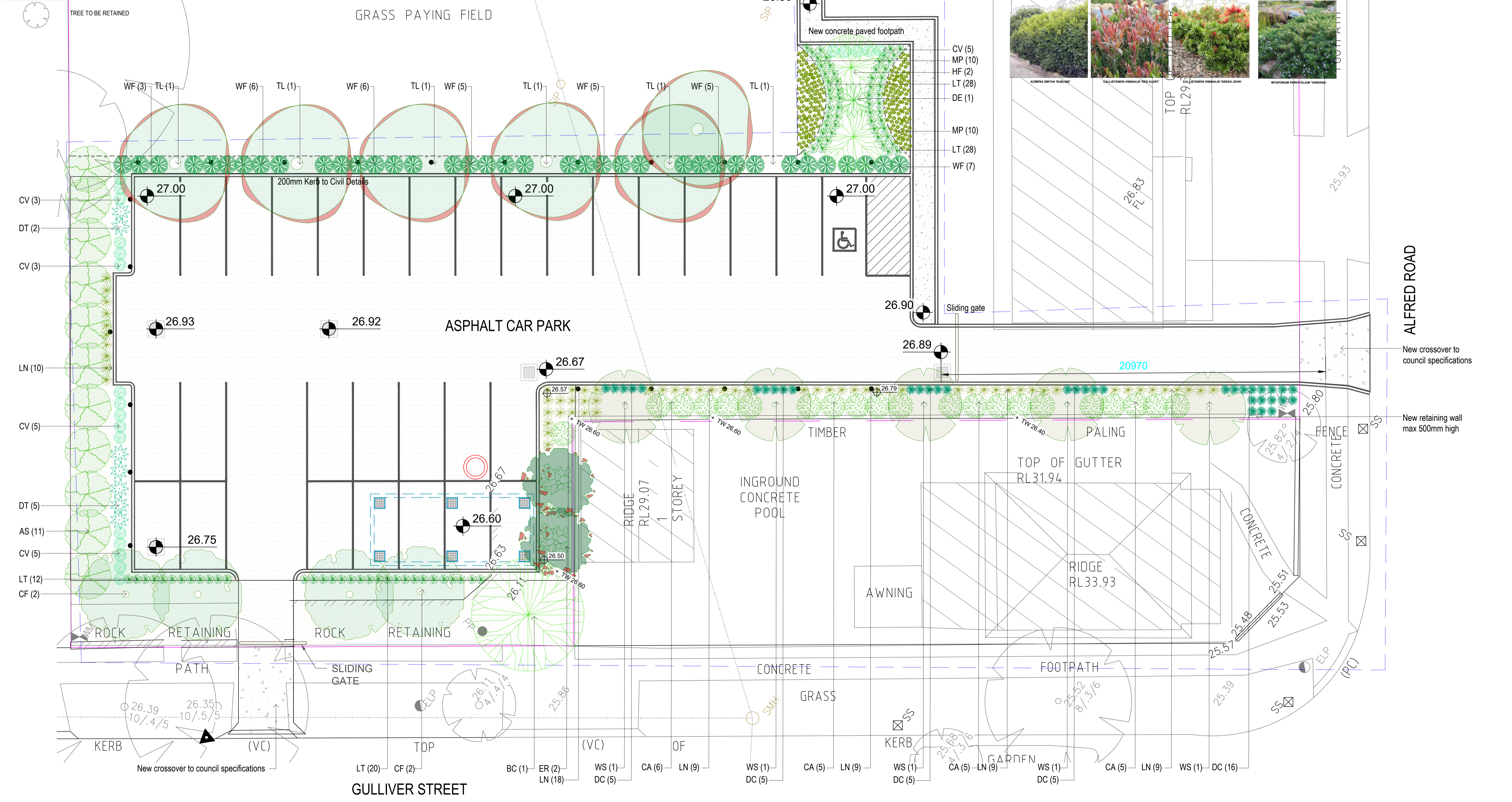
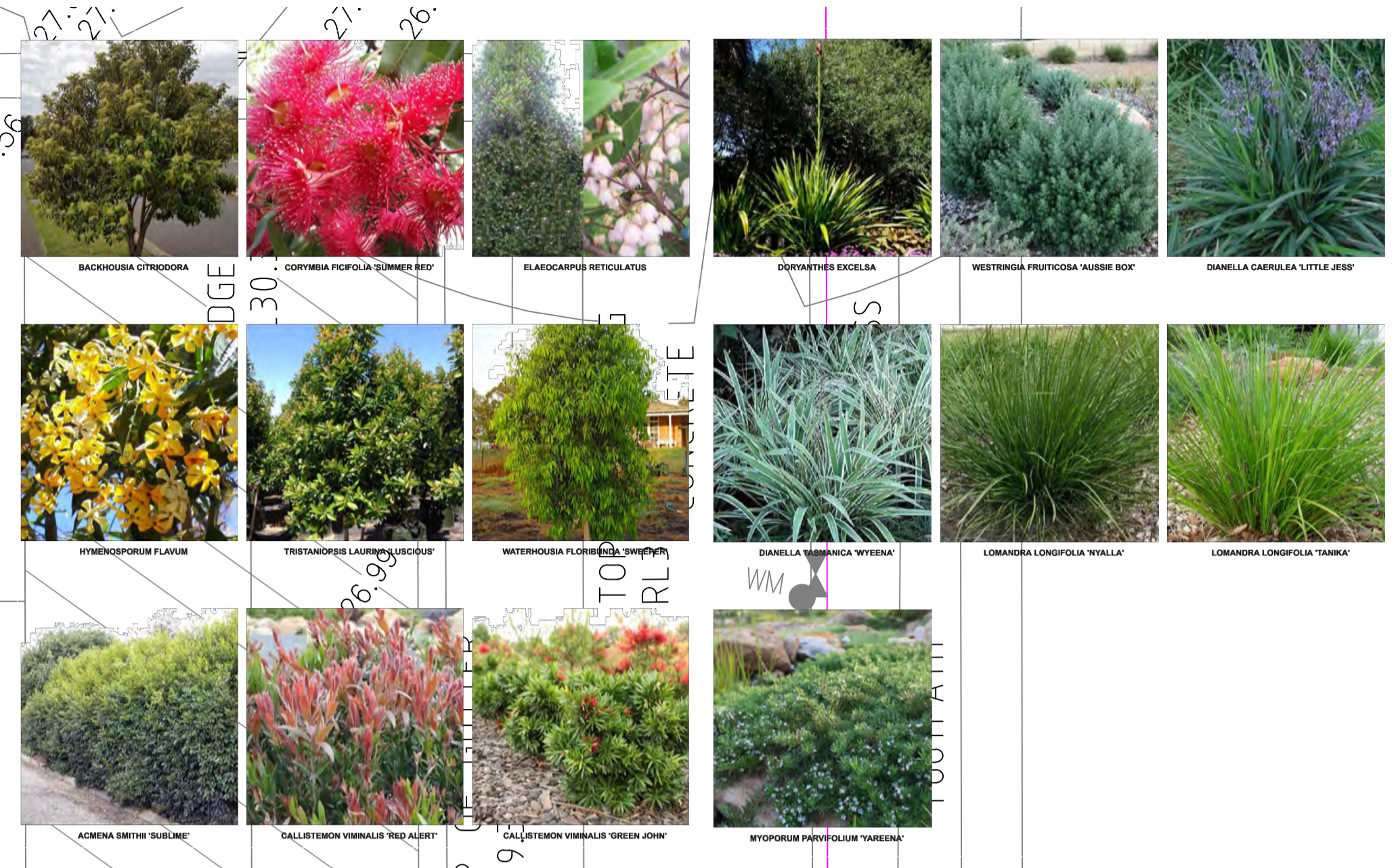

**NOTES**

1. Consider to check and verify all dimensions and all levels on site prior to any works.

2. Any alterations should be immediately referred to Space Landscape Designs.

3. All work to comply with all CA, State, Authority and relevant Australian Standards.

4. Contractors designed own details. All measurements are in millimetres.

Rev.	Date	Issue	Checked
A	20/10/21	Preliminary Issue	CW
B	22/10/21	Preliminary Issue	CW
C	26/10/21	Preliminary Issue	CW
D	26/10/21	GA Issue	CW

**SPACE LANDSCAPE DESIGNS**

Space Landscape Designs Pty Ltd  
 ABN 60 799 663 674 ACN 139 316 251  
 info@spacelandscape.com.au  
 spacelandscape.com.au  
 P 02 9905 7870 F 02 9905 7657  
 Suite 138, 117 Old Pittwater Rd, Brookvale NSW 2100

PROJECT: Proposed Carpark

SITE ADDRESS: Federal Parade, Brookvale 2100

CLIENT: St Augustine's College

DRN: A.Elboz (A/LDM 625)

SCALE: 1:100@A1

PROJECT NO: 211930

DRAWING TITLE: LANDSCAPE PLAN-SHEET 2

DRAWING NO: L-03

Rev. D

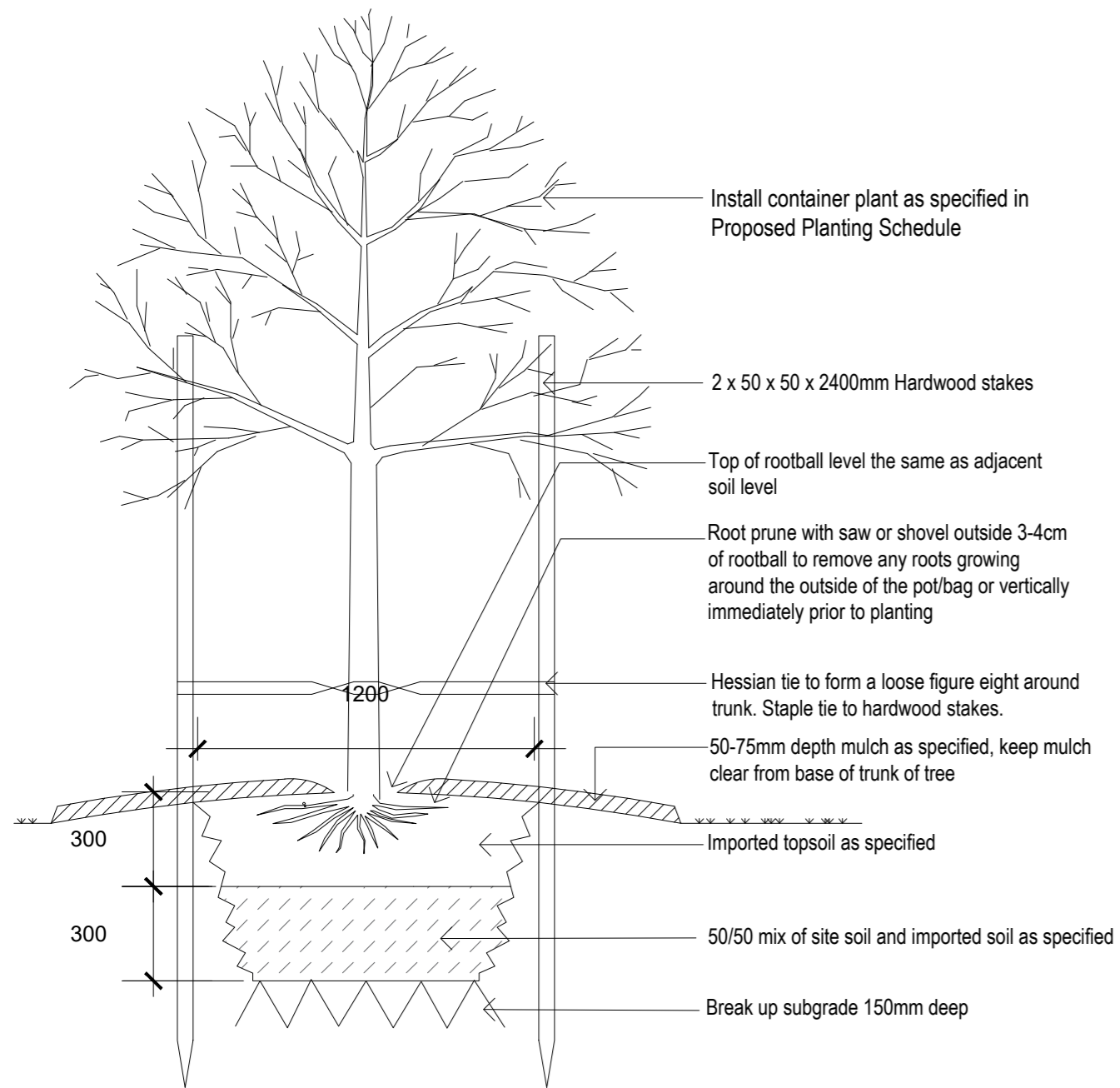

01 TYPICAL TREE PLANTING DETAIL  
SCALE 1:20

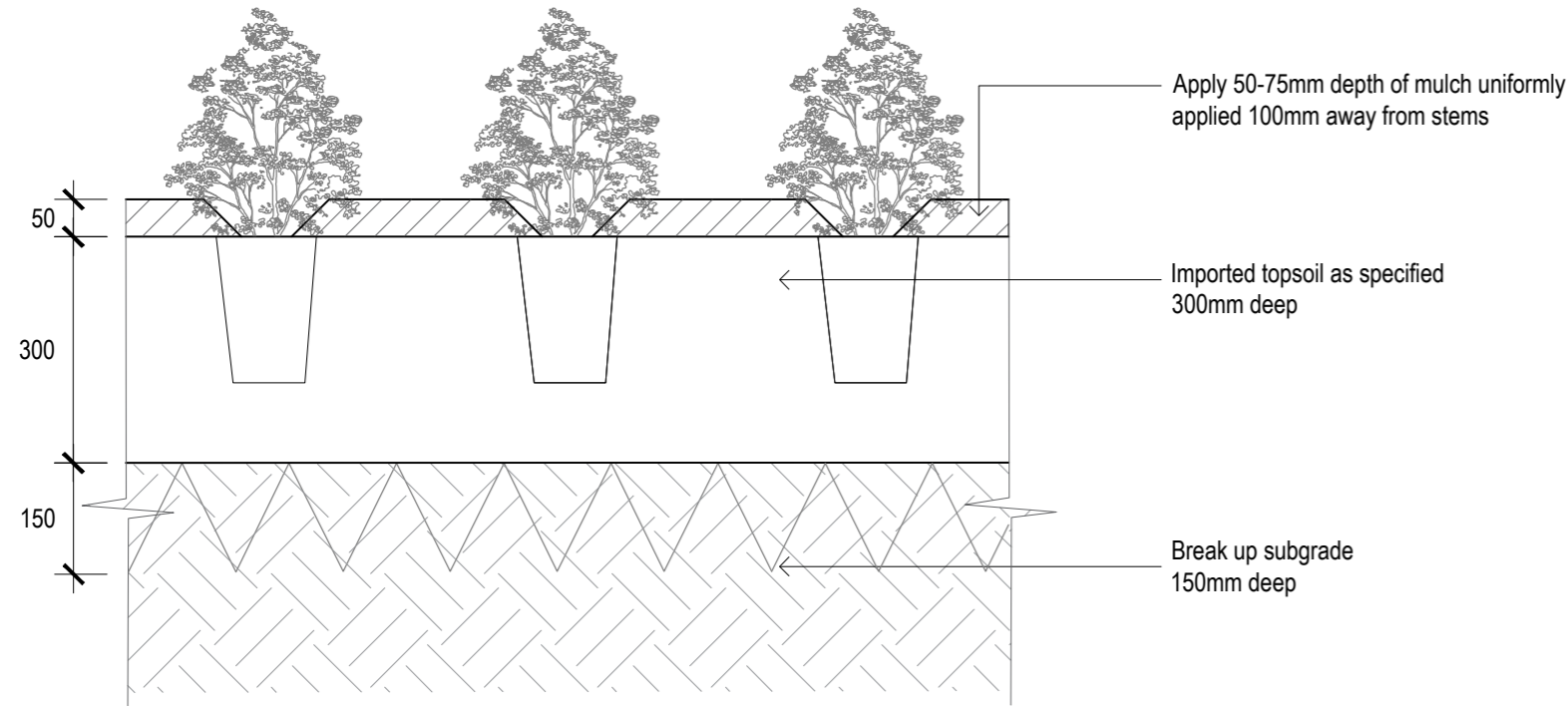

02 TYPICAL GARDEN BED DETAIL  
SCALE 1:10

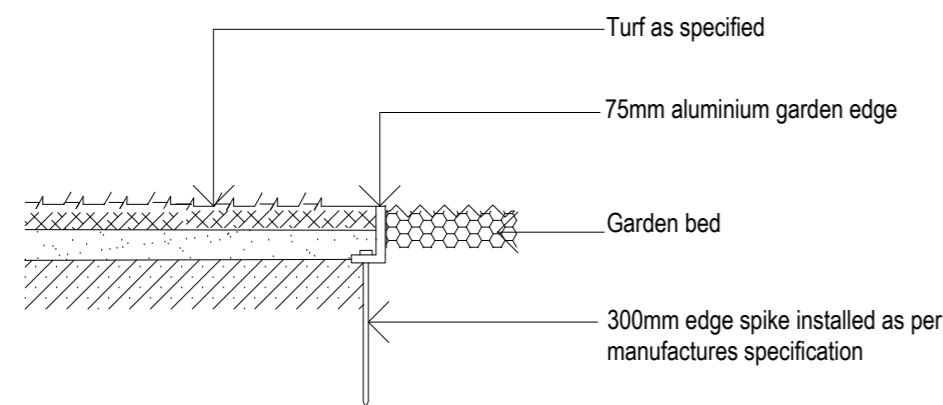

03 ALUMINIUM GARDEN EDGE DETAIL  
SCALE 1:10

**LANDSCAPE SPECIFICATION NOTES**

**SITE PREPARATION**

Locate any underground and overground services & ensure no damage occurs. Levels on plan are nominal only & all dimensions to be checked on site prior to commencement. Final structural integrity of all items shall be the sole responsibility of landscape contractor.

**WORKMANSHIP AND MATERIAL QUALITY**

Materials and workmanship are to conform to the current applicable Australian Standard Specifications and Codes. Any work or materials, which, in the opinion of the Site Manager do not meet appropriate industry standards should be rejected. Where works are adjacent to existing works, make proper junctions between new and existing works and make good any damage caused to adjoining existing and retained works.

**PROTECTION OF EXISTING TREES:**

Prior to construction, the builder shall erect tree protection fencing to the drip line of existing trees to be retained. The fence shall be constructed of star pickets at 2.4m spacings and connected by three strands of 2mm wire at 300mm spacings to a minimum height of 1500mm. Protect all trees affected by demolition & construction. Take necessary precautions to protect the Structural Root Zone (SRZ) as per AS 4970-2009 Australian Standard for Protection of Trees on Development Sites. Tree protection measures shall remain intact until the completion of all construction works.

Prohibited Works or material storage within the TPZ as per AS 4970-2009 except with approval of council:

- entry of machinery or storage of building materials, parking of any kind of vehicle
- erection or placement of site facilities, removal or stockpiling of soil or site debris
- disposal of liquid waste including paint & concrete wash
- excavation or trenching of any kind (including irrigation or electrical connections).
- attaching any signs or any other objects to the tree, placement of waste disposal or skip bins
- pruning and removal of branches, other than those by a qualified Arborist

Compacted Ground/Coring: Avoid compaction of the ground under trees. If compaction nevertheless occurs loosen the soil by Coring. Coring to be carried out by a qualified Arborist.

**REMOVAL OF EXISTING TREES**

All trees to be removed shall be carried out by a qualified arborist and work shall conform to the provisions of AS4373-2007 Australian Standards for The Pruning of Amenity Trees.

**ELIMINATE WEEDS**

Remove all existing weeds by hand, wiping or spraying with a glyphosate based herbicide. Weed control shall never be performed by mechanical cultivation or by scraping. Herbicide spraying is to be used to eliminate all existing weeds 30 days prior to planting.

**EXCAVATION & SUB SOIL PREPARATION**

Excavate garden beds to the depth required and rip or scarify base & sides of pit to a minimum depth of 150mm.

**SUB SOIL DRAINAGE**

Install drainage layer where there is surface water runoff draining into garden bed areas & where the existing sub-soil has more than 50% clay composition & there is a risk of subsurface water ponding.

Install perforated corrugated ag. line 75-100mm Dia. with geotextile filter sock & backfill to a minimum 200mm using free draining material, reclaimed/recycled where available. Direct flows at a minimum 0.5% fall to SW system. In areas isolated from stormwater system excavate & backfill an appropriate water dispersion pit.

**REUSE EXISTING TOPSOIL**

Existing site topsoil should be salvaged & appropriately stockpiled where possible.

**IMPORTED TOPSOIL**

All construction must comply with AS 4419-2003 Soils for Landscaping and Garden Use. Turf Areas: 'Turf Underlay', Tree Pit and Shrub Planting: 'Premium Garden Mix' as supplied by, ANL p: 02 9450 1444 or approved alternative. Spread the topsoil on the prepared subsoil and grade evenly, making allowances, if appropriate, for the following:

- Required finished levels and contours after light compaction.
- Compact lightly and uniformly in 150 mm layers. Avoid differential subsidence and excess compaction and produce a finished topsoil surface which has the following characteristics:
- Finished to design levels, smooth and free from stones or lumps of soil. Graded to drain freely, without ponding, to catchment points. Grade evenly into adjoining ground surfaces ready for planting.

**PLANTING AREA**

Remove weeds, rubbish, mulch and other debris. Do not disturb tree roots or services and if necessary cultivate these areas by hand. Spread topsoil on the prepared subsoil and grade evenly, making the necessary allowance to permit the required finished levels and contours after a light compaction. Spread topsoil to the typical depth of 300mm.

Feather edges into adjoining undisturbed ground.

**TREE STOCK**

Tree stock to be supplied by production nurseries in accordance with AS 2303:2018 Tree Stock for Landscape Use.

Health & Vigour: Supply plants with foliage size, texture & colour consistent with that shown in healthy specimens of the species. Balance of Crown: Supply plants with max. variation in crown bulk on opposite sides of stem axis, +/- 20%. Stock selection should also be based on NATSPEC Guide *Specifying Trees: a Guide to Assessment of Tree Quality*.

**STAKING**

Install 2 x 2400mm x 50mm x 50mm hardwood timber stakes with hessian ties to all trees. Provide appropriate support considering exposure to prevailing winds. Stakes and hessian ties to be removed as soon as the tree is self supporting.

**ALUMINIUM GARDEN EDGING**

Supply and install Link Edge 75mm as per Landscape Plan with safety top and flush to ground. Compact and level the base in the required area as indicated on Landscape Plan. Half hammer spikes into prepunched holes (approx 4 spikes every 3m length) starting from the first hole in the end of the Link Edge. Use spike washers supplied by manufacturer. Half hammer subsequent spikes in pivotal areas along the length. (Especially at points where a curve is required). Connect lengths together by using fish-plate connectors supplied by manufacturer. Check position of Link Edge is correct before hammering spikes firmly into ground.

**MULCHING**

All landscaping must comply with AS 4454-2003 Compost, soil conditioners and mulches. All planting areas to receive 50-75mm of garden Mulch, Droughtmaster, ANL p: 02 9450 1444 or approved alternative. Keep mulch 100mm away from plant stem & form a well to stop excessive water runoff. Finish flush with adjacent surfaces.

**WATERING**

Water in immediately after plant installation & allow for soil settlement. Watering program: Minimum 3 complete waterings, soaking to a depth of 150 mm at fortnightly intervals for the first 6 weeks of plant establishment irrespective of natural rainfall. Manually water all lawn and planting areas in absence of an irrigation system or until the proposed irrigation system is fully operational. Avoid frequent dampening of the surface. Allow the surface of the soil to partially dry out between waterings.

**NOTES:**  
- Contractors to check and verify all dimensions and all levels on site prior to any works.  
- Any discrepancies should be immediately referred to Space Landscape Designs.  
- All work to comply with B.C.A. Statutory Authorities and relevant Australian Standards.  
- Dimensions recognised over scaling. All measurements are in millimetres.

Rev.	Date	Issue
A	25/10/21	Preliminary Issue
B	09/12/21	DA Issue

Checked  
CW  
CW



**Space Landscape Designs Pty Ltd**  
ABN 60 799 663 674 ACN 139 318 251  
info@spacedesigns.com.au  
spacedesigns.com.au  
P 02 9905 7870 F 02 9905 7657  
Suite 138, 117 Old Pittwater Rd,  
Brookvale NSW 2100

PROJECT:  
**Proposed Carpark**  
SITE ADDRESS:  
**Federal Parade, Brookvale 2100**

CLIENT: **St Augustine's College**  
DRN: **A.Elboz (AILD625)**  
SCALE: **1:100@A2**  
PROJECT NO: **211930**

DRAWING TITLE: **LANDSCAPE DETAILS & SPECIFICATION**  
DRAWING No: **L-04**  
Rev: **B**