

Construction Certificate Determination

issued under the Environmental
Planning and Assessment Act 1979
Section 109C (1) (b) 81A (2) and 81A (4)

Certificate No. 2005/696

Council	Pittwater
Determination date of determination	Approved 1 July 2005
Subject land Address Lot No, DP No.	102 Waterview Street, Mona Vale Lot Y DP 419505
Applicant Name Address Contact No. (phone)	Stephen & Stephanie Yates 102 Waterview Street, Mona Vale NSW 2103 9979 1819
Owner Name Address Contact No. (phone)	Stephen & Stephanie Yates 102 Waterview Street, Mona Vale NSW 2103 0408 818 465
Description of Development Type of Work	Inground Swimming Pool
Builder or Owner/Builder Name Contractor Licence No/Permit	Stephen Yates Permit No. 28377P
Value of Work Building	\$35,000.00

Attachments

1. Pittwater Council receipt no. 139411, dated 6 April 2004, for payment of Long Service Levy

**COUNCIL
COPY**

Plans & Specification**approved**

List plans no(s) & specifications
Reference

1. Site Plan & Architectural Plan, reference no. TSMK-84 Sheets 2, & 5 Issue 1, dated 22 September 2003, prepared by Calldart Pty Ltd
2. Structural Engineers Plans & Details, reference 04108-02 Rev B, dated May 2004, prepared by Henry & Hymas
3. Sydney Water approval dated 6 April 2004
4. Landscape Plan & Specifications Drg No 02/003 & details (5 pages) all dated 7/6/2004 prepared by Horticultural Solutions & Landscape Design

Certificate

I certify that the work if completed in accordance with these plans and specifications will comply with the requirements of S81A(5) of the Environmental Planning and Assessment Act 1979.

Signed



01 JUL 2005

Date of endorsement
Certificate No.

2005/696

Certifying Authority

Name of Accredited Certifier
Accreditation No.
Accreditation Authority
Contact No.
Address

Stephen Pinn
POO40
Dept of Infrastructure, Planning & Natural Resources
(NSW Accreditation Scheme)
(02) 9999 0003
13/90 Mona Vale Road, Mona Vale NSW 2103

Development Consent

Development Application No.
Date of Determination

NO926/03
24 February 2005

BCA Classification

10b

Pittwater Council

REPRINTED

OFFICIAL RECEIPT

06/04/2004 Receipt No 139411

FO MR & MRS YATES

102 WATERVIEW ST
MONA VALE
NSW 2103

Applic Reference	Amount
EL No - 6161-Buil L X 04.N0926/03	\$296.00

Totals \$296.00

Amounts Tendered

Cash	\$0.00
Cheque	\$296.00
Card	\$0.00
Money Order	\$0.00
Agency Rec	\$0.00
Total	\$296.00
Rounding	\$0.00
Change	\$0.00
Nett	\$296.00

Printed 06/04/2004 11:29:39

Cashier JTretl

**COUNCIL
COPY**

SYDNEY WATER

FILLING OF SWIMMING POOLS

The water supply to the pool must be drawn from a metered service and any tap or hose used to fill the pool must be at least 150mm above the highest possible water level of the pool.

EMPTYING OF SWIMMING POOLS

- Pools emptying into Sydney Water's Sewer must
- Discharge into a gully through a pipe.
 - Discharge only in dry weather, with prior approval from Sydney Water's Customer Centre.

NOTE: IT IS PROHIBITED TO DISCHARGE POOL WATER INTO ANY OF SYDNEY WATER'S VACUUM SYSTEM SEWERS.

Tradelink, Mona Vale,
Quick Check Agent on behalf of
SYDNEY WATER

Per: TRADELINK 6/4/04

SYDNEY WATER APPROVED

- Position of structure in relation to Sydney Water's assets is satisfactory.
- Connections to Sydney Water sewer/water services may only be made following the issue of a permit to a licenced plumber/drainier.
- It is the owner's responsibility to ensure that all proposed fittings will drain to Sydney Water's sewer.
- Any Plumbing and/or Drainage Work to be carried out in accordance with the Sydney Water Act 1994, AS 3500 and the NSW Code of practice.
- Gullies, Inspection Shafts and Boundary Traps shall not be placed under any Roof, Balcony, Verandah, Floor or other cover unless otherwise approved by Sydney Water.
- Property No. 3462687

Tradelink, Mona Vale,
Quick Check Agent on behalf of
SYDNEY WATER

Per: TRADELINK 6/4/04

COUNCIL COPY

SITE AREA: 735.80m²
 EXISTING GROUND FLOOR: 163.38m²
 EXISTING 1ST FLOOR: 106.41m²
 NEW 1ST FLOOR: 57.27m²
 NEW POOL: 32.00m²

insight development consultants pty ltd
 CONSENT NO. *10 226/03* DATE *24/2/2003*
 CONSTRUCTION CERT. NO. *205/696*
CONSTRUCTION CERTIFICATE PLANS
 S Pinn Accreditation No. P00 40

COUNCIL COPY

CALLDART Pty Ltd.
 ARCHITECTURAL DESIGN & PLAN SERVICE
 1/18-20 Victoria Parade, Monby, 2095, A/N: 84 083 033 063
 Phone: 9976 3613, 0407 017 075

PROJECT: **PROPOSED FLOOR ADDITION & POOL**
 No 102 WATERVIEW STREET
 MONA VALE

CLIENT: **MR. & MRS. YATES**

COPYRIGHT:
 All plans and drawings are subject of copyright and any attempt or actual infringement by using, reproducing or copying some, wholly or in part, without prior written permission will result in legal proceedings.

DATE: 22/09/2003 SCALE: 1:200
 DRAWN: TONY SWEENEY SHEET: 2 OF: 10
 DRAWING NO.: TSMK_84 ISSUE: 1

WARNING
 The stamping of this plan by Insight Development Consultants Pty Ltd does not relieve:
 • The applicant's responsibility to obtain approval from Sydney Water or other utilities.
 • The Structural Engineer of their responsibility to ensure the structural adequacy of this project.
 • The Applicant, Structural Engineer or other Professional of their responsibility to ensure these stamped details are consistent with the issued Construction Certificate Architectural Details.

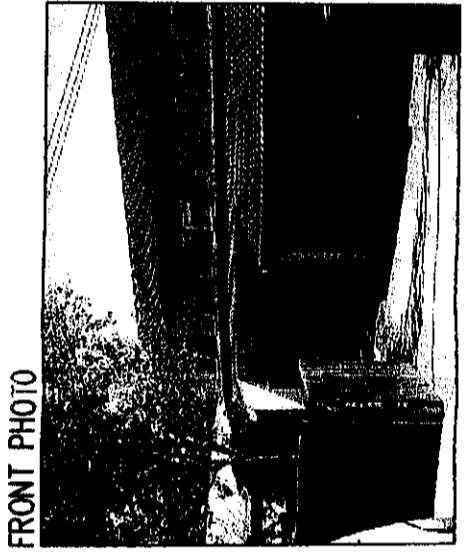
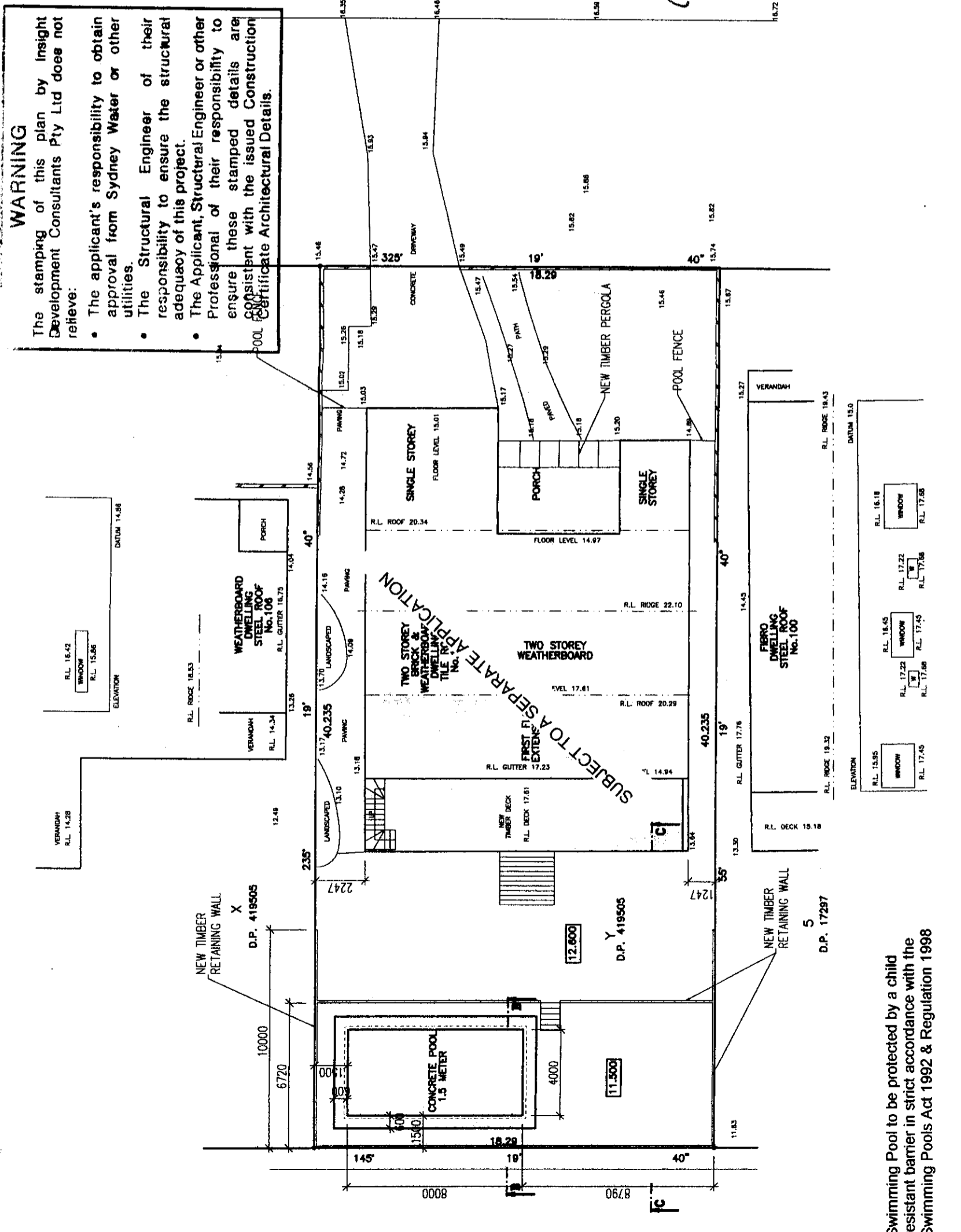

Swimming Pool to be protected by a child resistant barrier in strict accordance with the Swimming Pools Act 1992 & Regulation 1998

PROPOSED SITE PLAN 1:200

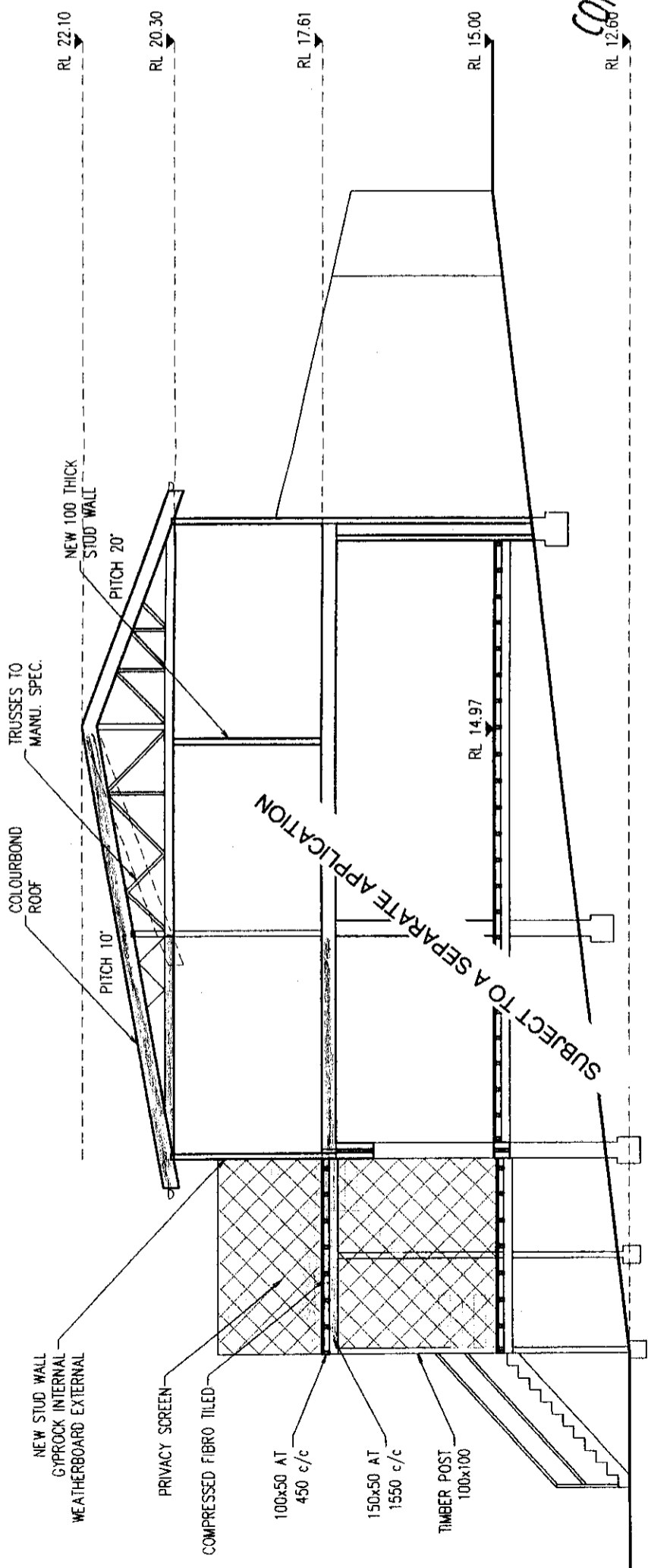

SECTION A-A 1:100

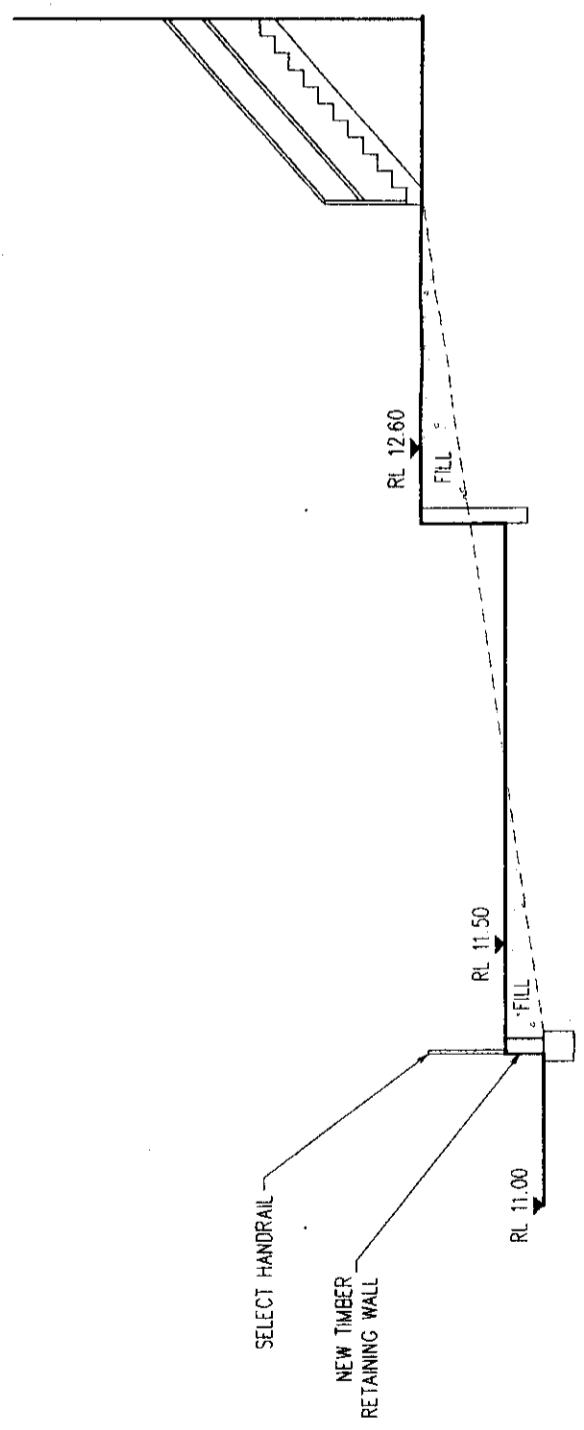

SECTION C-C 1:100

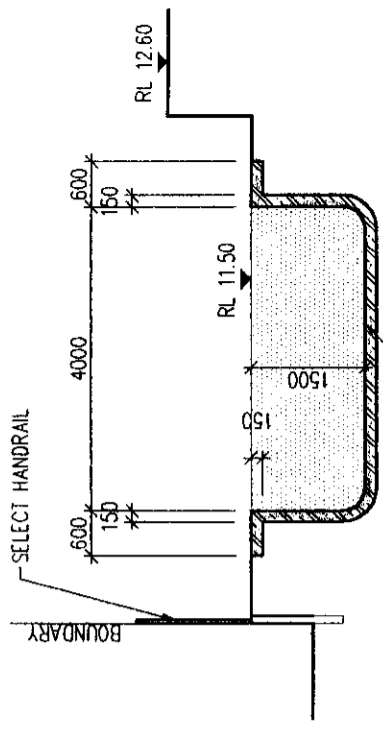

APPROVED DEVELOPMENT BY WATER COUNCIL
SECTION B-B 1:100
CONSENT PLANS

NOTE: THESE PLANS MUST BE READ IN CONJUNCTION WITH THE CONDITIONS OF DEVELOPMENT CONSENT

COMPANY: **CALLDART Pty. Ltd.**
 ARCHITECTURAL DESIGN & PLAN SERVICE
 1/18-20 Victoria Parade, Manly, 2095, ABN: 84 063 033 063
 Phone: 9976 3613, 0407 017 075

PROJECT: **PROPOSED FLOOR ADDITION & POOL**
 No 102 WATERVIEW STREET
 MONA VALE

CLIENT: **MR. & MRS. YATES**

COPYRIGHT:
 All plans and drawings are subject of copyright and any attempt or actual infringement by using, reproducing or copying same, wholly or in part, without prior written permission will result in legal proceedings.

DATE: 22/09/2003	SCALE: 1:100
DRAWN: TONY SWEENEY	SHEET: 5 OF: 10
DRAWING No: TSMK_84	ISSUE: 1

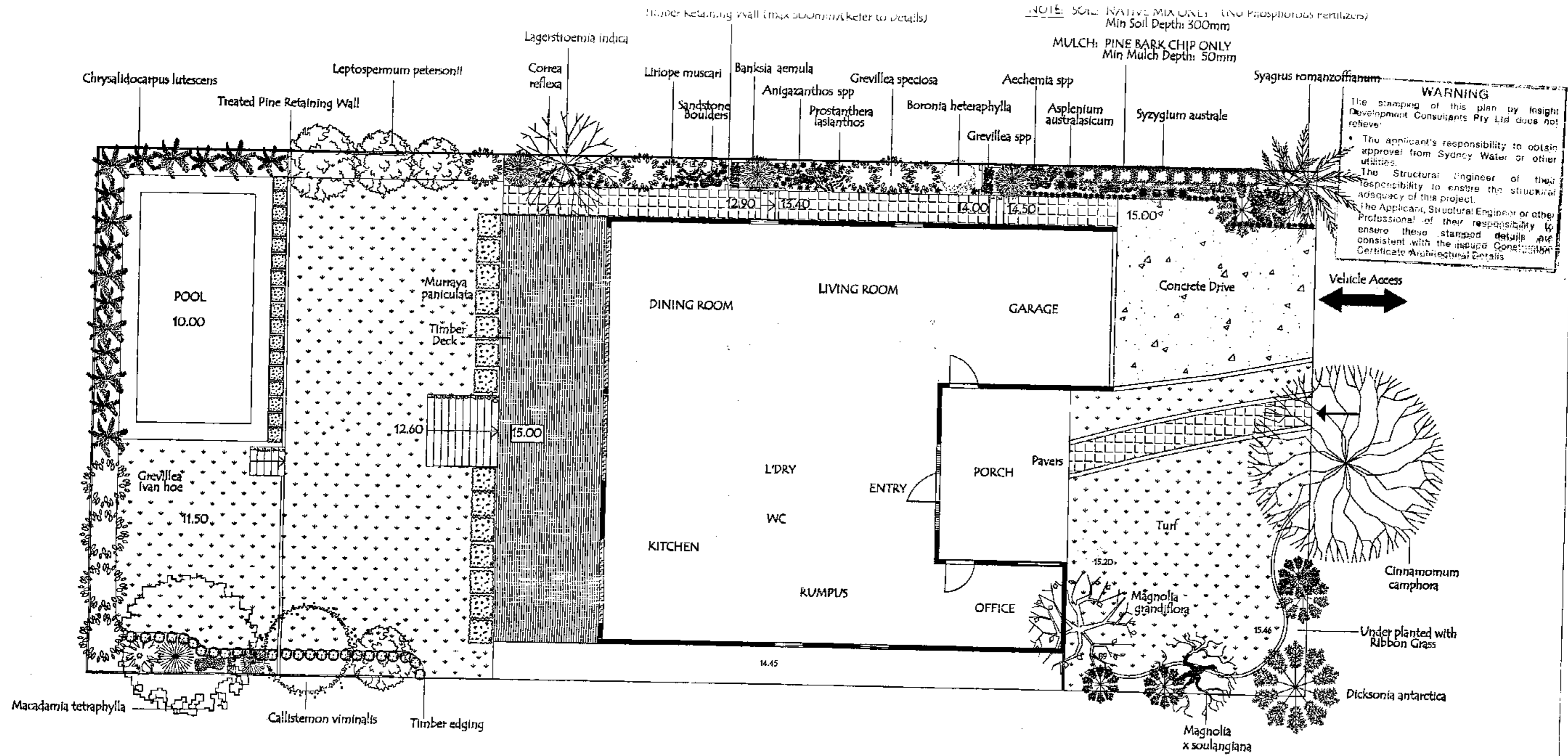

PLANT SCHEDULE

- Banksia aemula (Wallum Banksia) 12" Pot x3
- Grevillea speciosa (Red Spider Flower) 12" Pot x6
- Boronia heterophylla (Kalgan Boronia) 8" Pot x1
- Dicksonia antarctica (Soft Tree Fern) Budd Cuttings x2
- Prostanthera lasianthos (Victorian Christmas Bush) 12" Pot x1
- Correa reflexa (Native Fuschia) 8" Pot x5
- Syzygium australe (Lilly Pilly) 12" pot x10
- Anigazanthos spp (Kangaroo Paw) 4-6" Pot x30
- Grevillea "Poortinda Royal Mantle" (Royal Mantle Grevillea) 8" Pot x4
- Aechmea spp (Bromeliade) 8" Pot x21
- Asplenium australasicum (Birds Nest Fern) 12" Pot x6
- Callistemon viminalis (Lemon Scented Bottle Brush) 12" Pot x1
- Leptospermum petersonii (Lemon scented Tee Tree) 12" Pot x4
- Chrysalidocarpus lutescens (Golden Cane Palm) 12" Pot x10
- Liriope muscari (Lily Turf) 4-6" Pot x56
- Murraya paniculata (Murraya) 12" pots x17

EXISTING PLANT SPECIES

- Macadamia tetraphylla (Nut Macadamia) Height: 5m, Healthy, Severe Crack In Trunk
- Syagrus rosmanzoffianum (Cocos Palm) Height: 15m, Healthy
- Magnolia grandiflora (Bull Bay Magnolia) Height: 5m, Healthy
- Magnolia x soulangiana (Saucer Magnolia) Height: 3.5m, Healthy
- Cinnamomum camphora (Camphor Laurel Tree) Height: 15x2m, Aged, Hazardous
- Lagerstroemia indica (Crape Myrtle) Height: 3m x 3m, Healthy
- Agapanthus orientalis (Agapantha)

SURFACES

- Stenotaphrum secundatum (Buffelo Turf)
- Sand Stone Flagging
- Concrete Surfaces
- Timber Decking



NOTE: No Advanced Native Specimens
No Staking Required
Plant Species shown at semi-mature age

This Plan is in accordance with D.C.P No 23
Landscape & Vegetation Management
of Pittwater Council

Horticultural Solutions & Landscape Design
916/22 Central Ave, Manly, 2095

Client:	Mr & Mrs Yates
Project:	PROPOSED PAVING & GARDEN BED DESIGN 102 Waterview Street, Mona Vale
Plan:	CONCEPT/SKETCH PLAN ©
Drawn:	MATT GIBBS
Date:	5/6/2004
Dwg No:	002/005
Sign:	7/6/2004

Scale: 1:100

COPY

Horticultural Solutions & Landscape Design

916/22 Central Ave, Manly, 2095 Office: 0415 561 648

Landscape Details, Cross Sections & Elevations

PROPOSED PATHWAY & GARDEN BED CONSTRUCTION

ADDRESS: 102 Waterview Street, Mona Vale.

CLIENTS: Mr & Mrs Yates

- DRAWINGS:
1. Treated Pine Retaining Wall Elevation (1:20)
 2. Step & Timber Wall Section & Elevation (1:20)
 3. Step Cross Section & Detail (1:20)
 4. Pathway & Step Cross Section (1:100)

 7/6/2004

All Drawings Done By Matt Gibbs (Horticulturist & Landscape Designer)
All Drawings ©

TREATED PINE RETAINING WALL DETAILS

DETAIL 1
SCALE: 1:20

PLAN VIEW

DETAIL 2
SCALE: 1:20

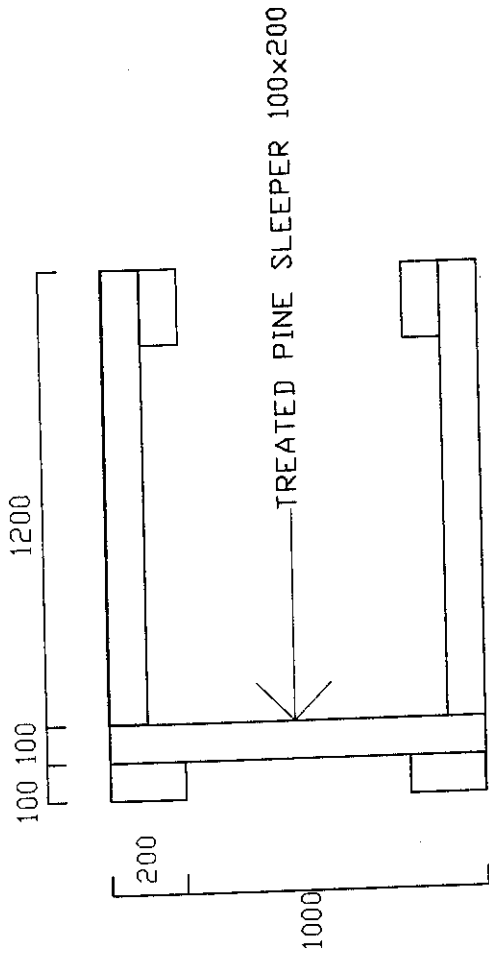
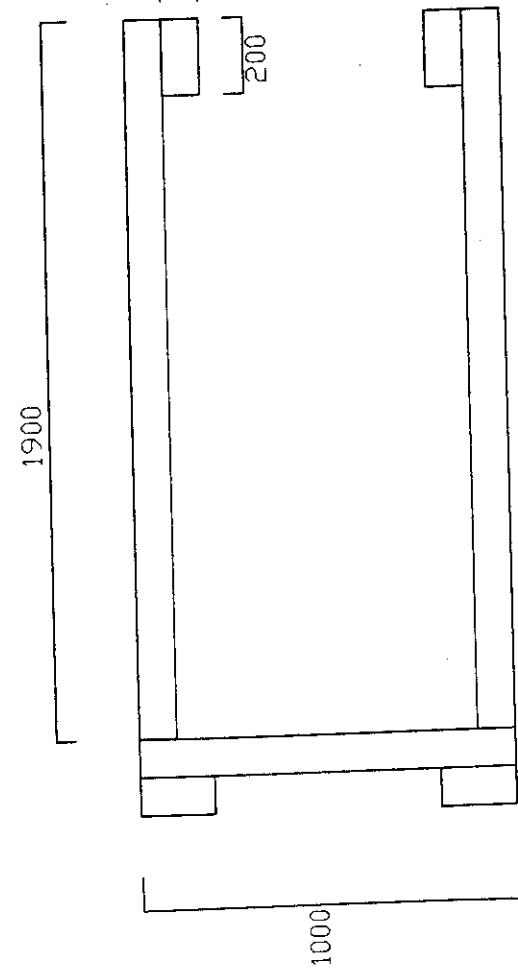

ELEVATION A-A

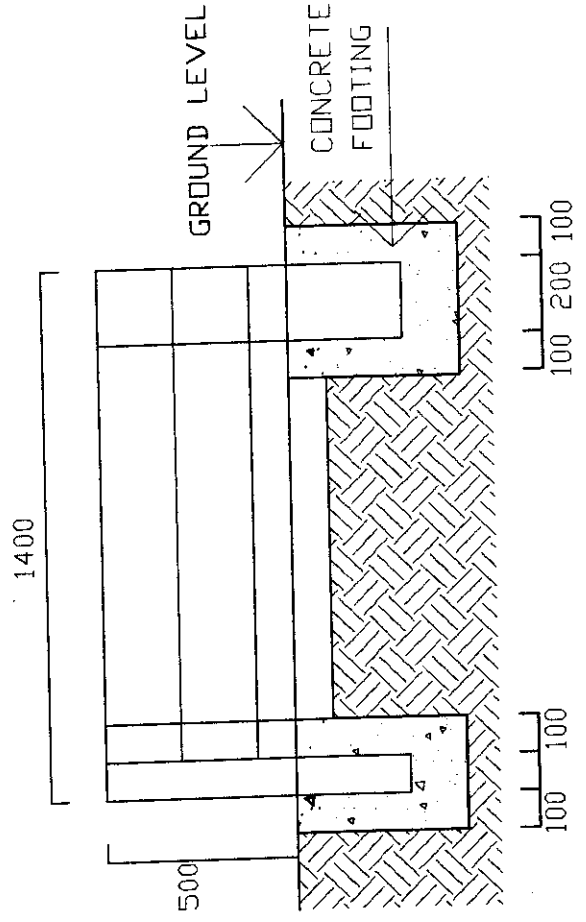
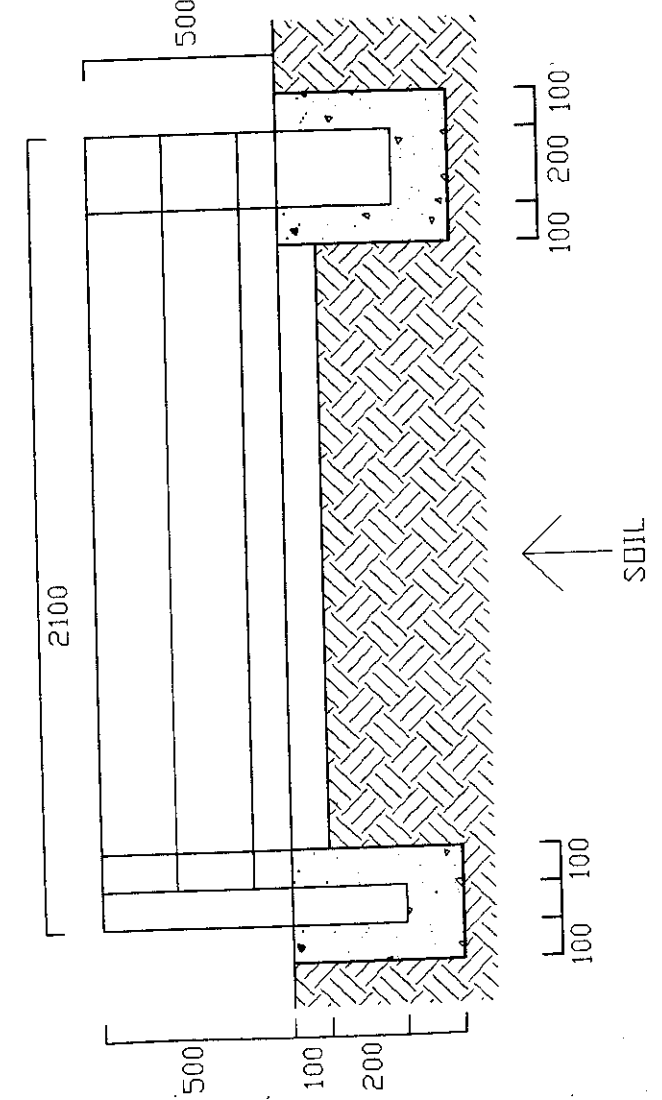

7/6/2004

STEP & TIMBER WALL SECTION & ELEVATION

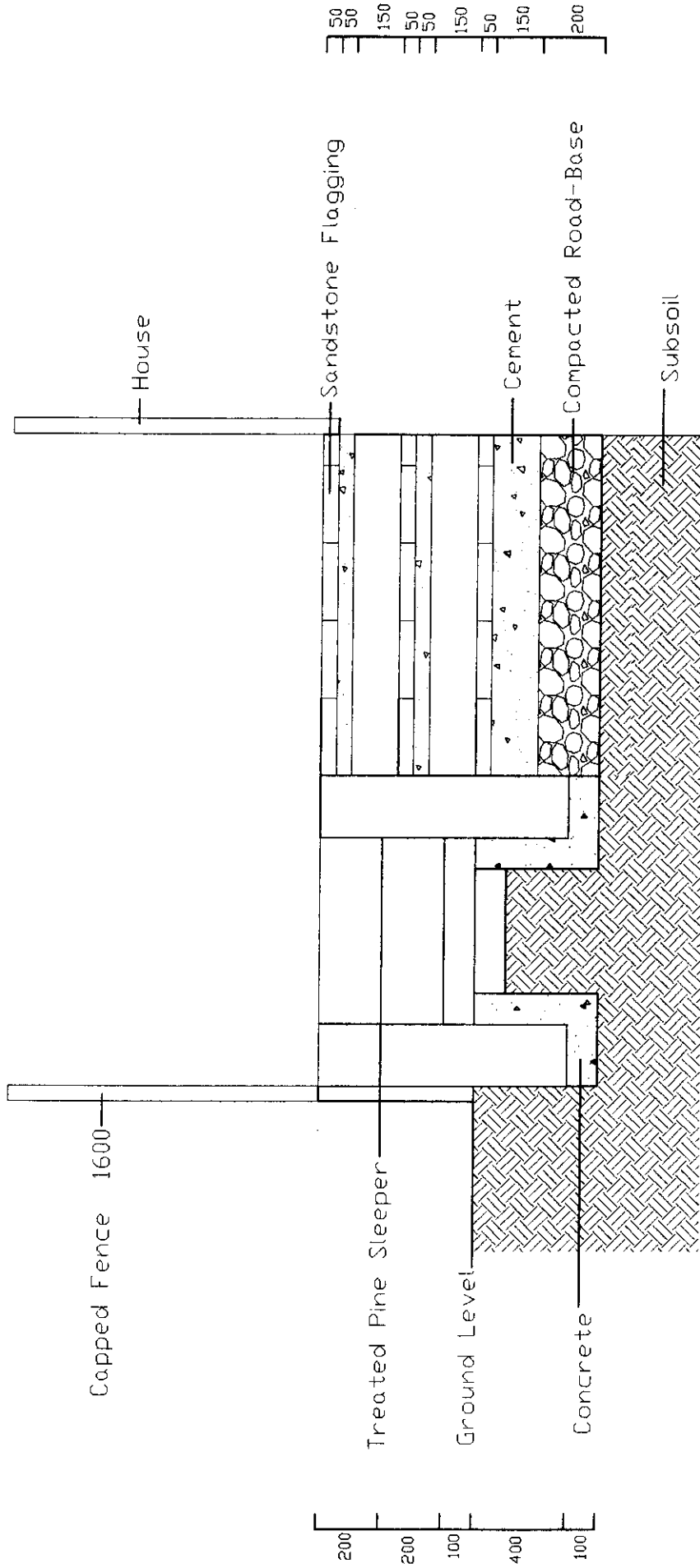

Scale 1:20



7/16/2006

STEP CROSS SECTION & DETAIL

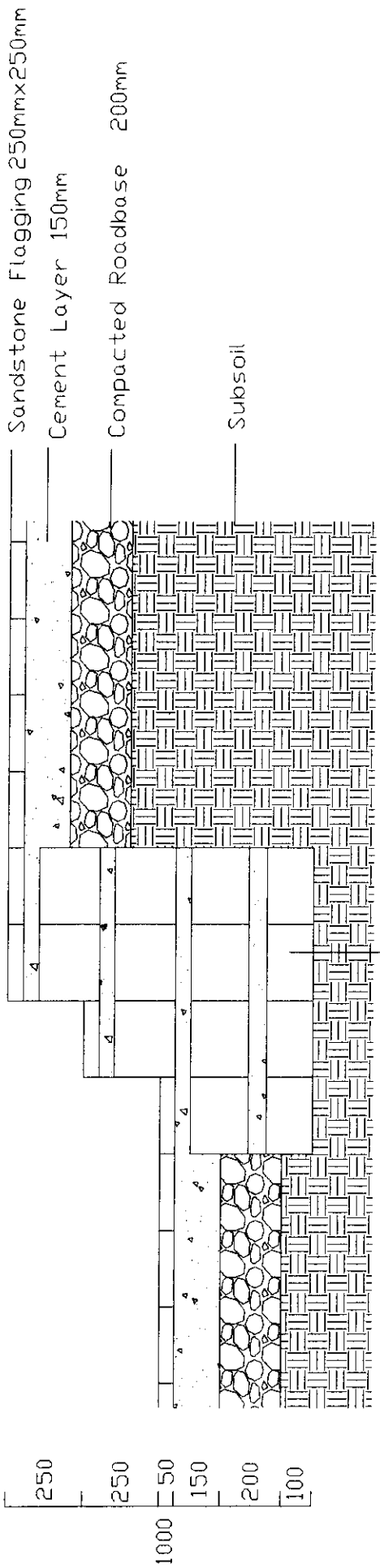

Scale: 1:20

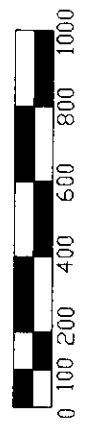

~~7/6/2004~~ 7/6/2004

PATHWAY & STEP CROSS SECTION

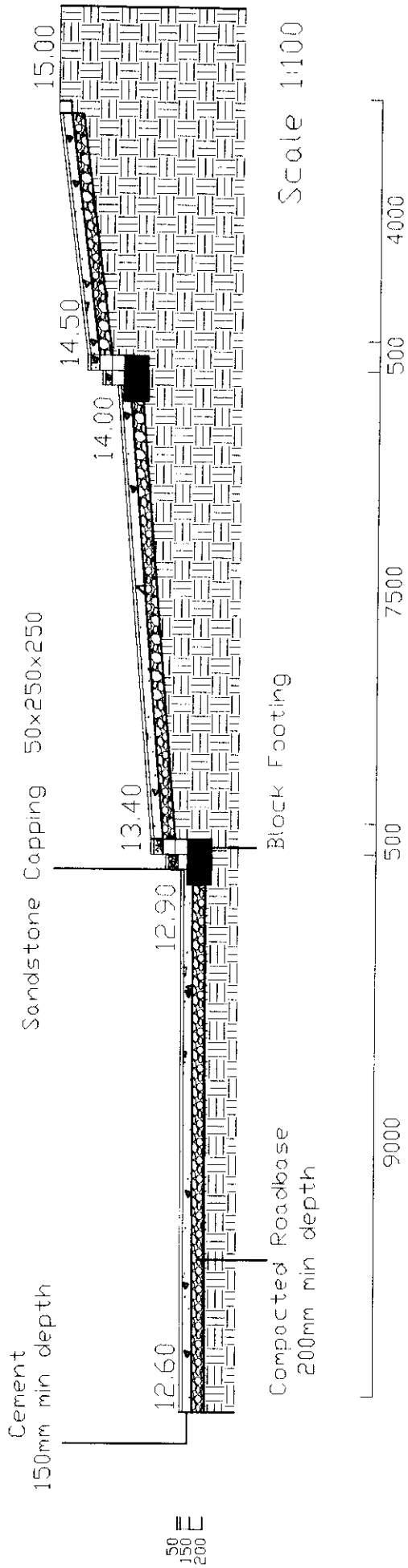

PATHWAY & RETAINING WALL CROSS SECTION

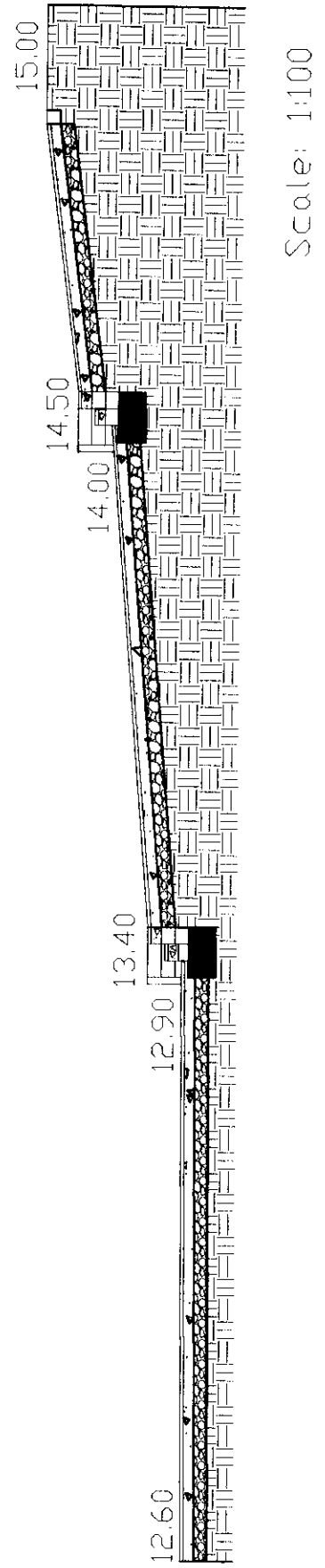

[Signature]
7/6/2004