

A
LOCATION OF PROPOSED SCOREBOARD SIGNAGE

LIGHT POLE

SITE PLAN
SCALE 1:500
SHOWING LOCATION OF PROPOSED SCOREBOARD SIGNAGE

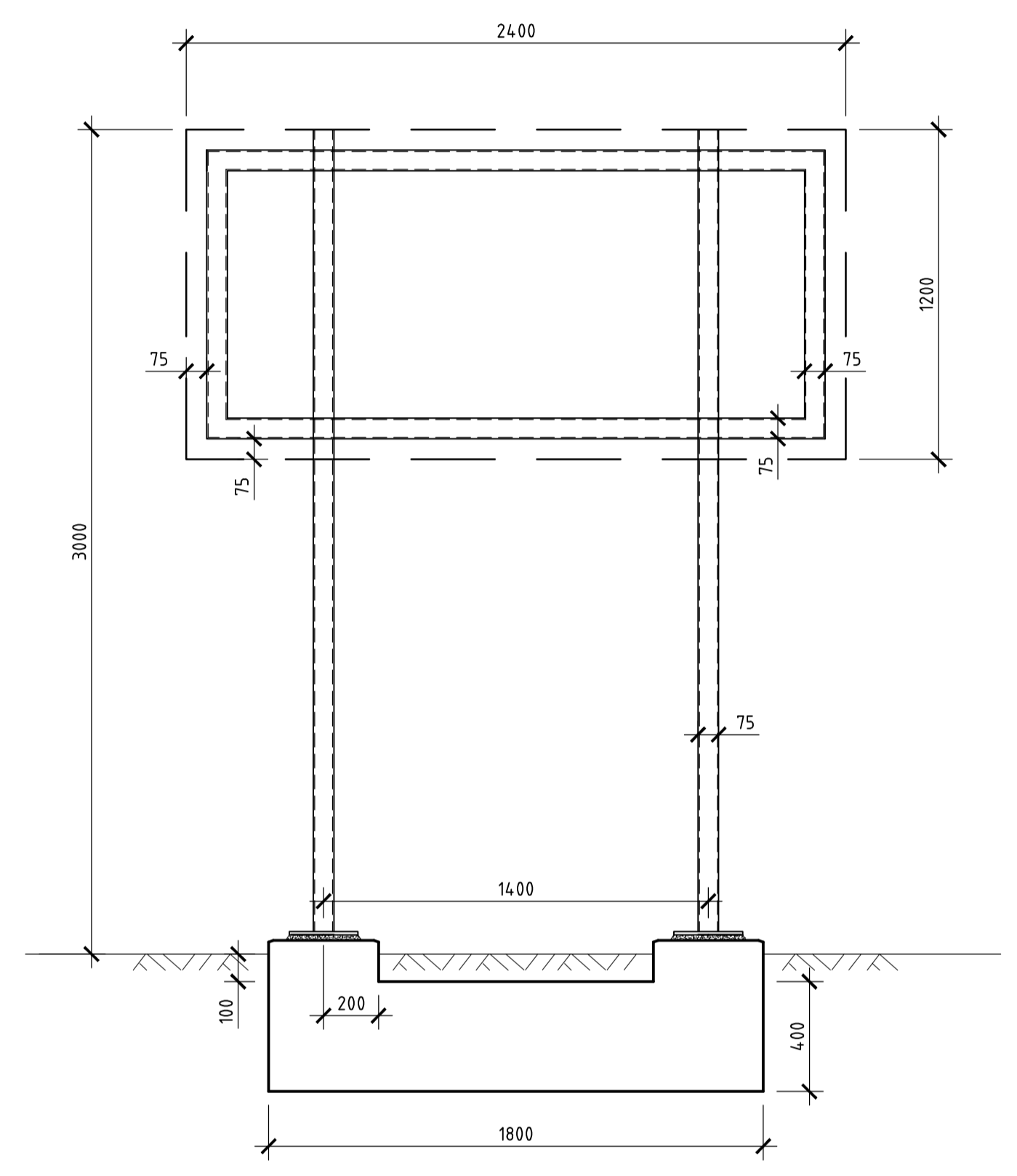

DETAIL A
SCALE 1:20
REFER DRG. NO. 23012.S1
D'O'BRIEN ENGINEERING SERVICES PLT. LTD.

ABBREVIATIONS

U.O.N.	UNLESS OTHERWISE NOTED
T	TOP
B	BOTTOM
H.D.	HOT DIPPED
GALV.	GALVANISED
MIN.	MINIMUM
c/c	CENTRE TO CENTRE
SQ.	SQUARE
TYP.	TYPICAL

ISSUE DATE	REVISION

TITLE PROPOSED SCOREBOARD SIGNAGE JAMES MORGAN RESERVE, CROMER			
DRAWN CC	DATE 3 FEBRUARY 2025	CHECKED <i>[Signature]</i> BE Civil (Hons) MIE Aust.	SCALE @ A1 1:500 1:20
ENGINEER BTT			

TAYLOR CONSULTING
CIVIL & STRUCTURAL ENGINEERS

LAYOUT -1

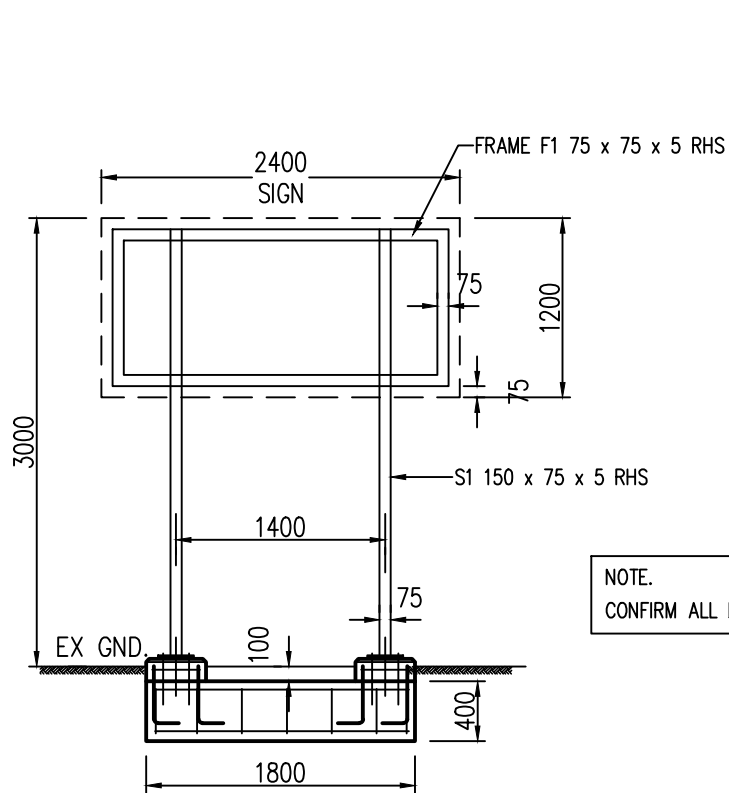

SCOREBOARD SIGNAGE 1:50

STRIP FOOTINGS

SF1 - 400D x 500W x 1.8M STRIP FOOTING, 5F11 TM T+B, N12-300 TIES

POSTS

S1 - 150 x 75 x 5 RHS SUPAGAL
 - 12 BASE PL+4M16 GHEMSET HD BOLTS EMBED 200

SIGN FRAME

F1 - 75 x 75 x 5 SHS SUPAGAL WELDED FRAME

NOTE.
 CONFIRM ALL DIMENSIONS ON SITE.

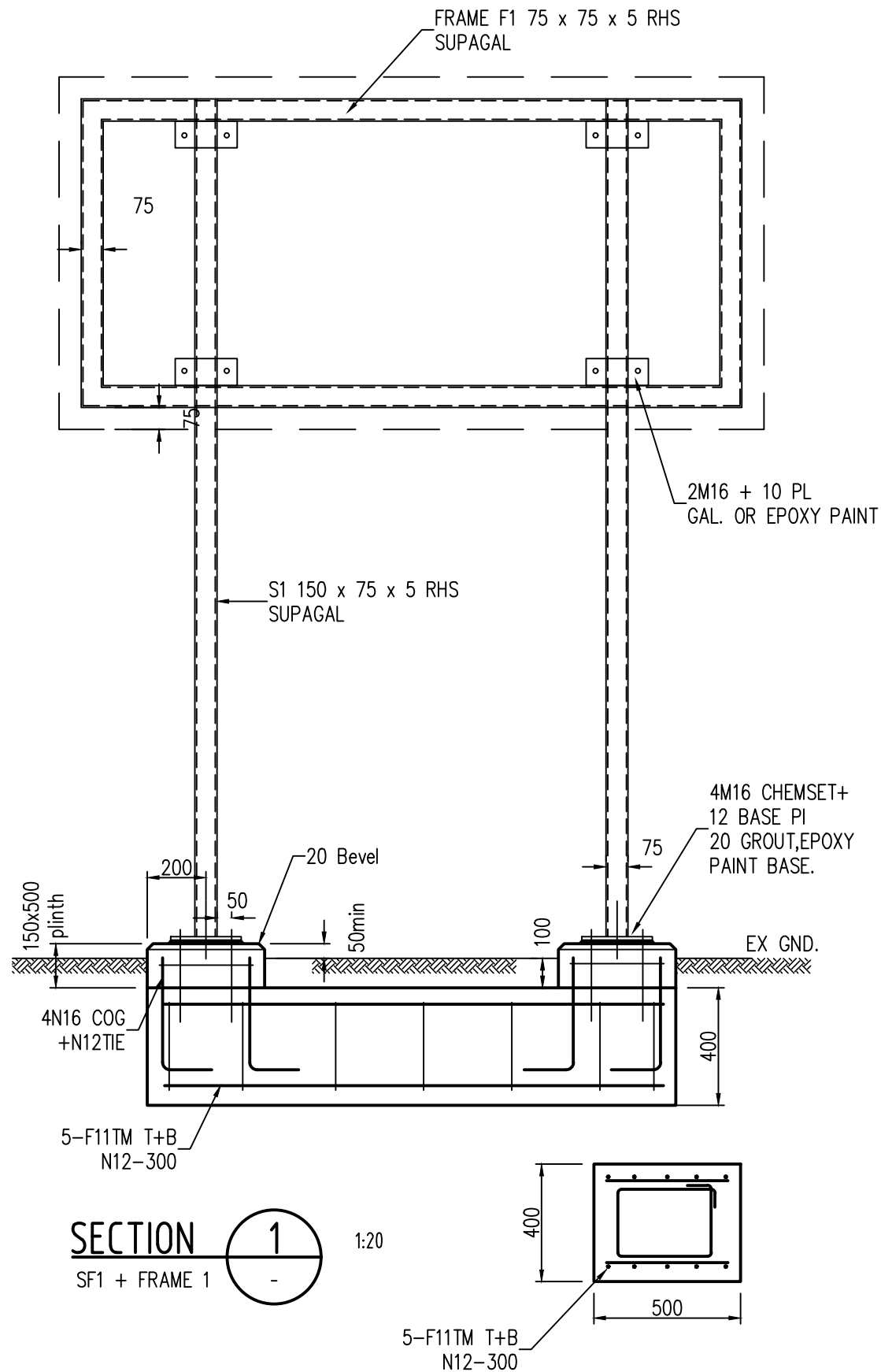

SECTION 1 1:20
 SF1 + FRAME 1

GENERAL NOTES

GENERAL

- Structural drawings are based on and shall be read in conjunction with all approved Architectural drawings, specifications, and other written instructions as may issued during the course of the contract. Dimensions shall be taken from the Architectural drawings or the actual work. The builder must verify all dimensions on site before commencing any work.
- Lines and locations of existing work is shown on the drawings as indicative only. The builder is to check and refer any discrepancies to the engineer. The adequacy of the existing structures is not covered in these drawings U.N.O.
- Only certified design details and certified drawings for the proposed new work shall be used for construction on site.
- The details shown on the drawings cover the extent of the new structural work. Existing work is not included, unless noted, in the new work.
- The construction shall follow the member sizing and design intent as shown on the drawings.
- All work shall be in accordance with The Building Code of Australia, current relevant S.A.A. Codes and those of all Statutory Authorities having jurisdiction over the work.
- Substitutions, where necessary, shall be approved by the Engineer, and allowed for by the builder in his tender.
- Approval given on shop drawings covers structural detail only and does not include dimensions and setout.
- During construction, the structure shall be maintained in a safe and stable condition and shall not be overstressed. If the work shown on the drawings is to be built in stages, refer to the engineer for advice on adequacy of the staged works.

FOUNDATIONS

- Foundation materials are to be approved for the following safe bearing pressures prior to placement of concrete.

Strip Footings	150 kPa	Pad Footings	150 kPa
Floor Slabs		Floor Slabs	kPa
Piers		Ribs to Slabs	kPa
Edge Beams to Slabs			
- Site classification in accordance with A.S.2870 is
- U.N.O. reinforcement for strip footings and to beams and ribs to slabs on ground shall be lapped full width at corners and intersections and 500mm at splices, and shall be carried continuously through any intersecting pad footing.

CONCRETE

- All workmanship, materials and testing shall comply with A.S.3600.
- Concrete shall have the following properties and shall attain the specified strength (N) at 28 days.

Location	N	Slump (mm)	Aggregate Size (mm)	F'c (MPa)
FOOTING	25	80	20	25

STEELWORK

- All steelwork shall be in accordance with A.S.4100. Steel shall comply with A.S.1204 and hollow sections shall be manufactured to A.S.1163 Grade 350, U.N.O.
- U.N.O. welds shall be 6mm continuous fillet welds Category GP(6CFW) full perimeter of contact with E41XX electrodes. All welding shall be in accordance with A.S.1554. All butt welds and all fillet welds 5mm and over shall be Category SP.
- U.N.O. use black bolts, grade 4.6/s to A.S.1111 in 2mm clearance holes. (4.6/s) Notation for high strength bolts to A.S.1252 is as follows:
 8.8/s High Strength Bolts installed snug tight.
 8.8/TF High Strength Bolts in friction grip mode.
 8.8/TB High Strength Bolts in bearing mode.
 The nominal bolt diameter is denoted thus: M20 = 20mm.
 Attention is drawn to the use of Hard Grade washers with High Strength bolts. All exposed bolts are to be galvanised U.N.O.
- U.N.O. use a minimum connection consisting of 10mm cleat plates, 6CFW, and 2 N°. M20 4.6/s bolts.
- Two copies of shop drawings are to be approved by the Engineer prior to the commencement of fabrication.
- U.N.O. seal all tubes with 5mm plate and continuous fillet weld.
- Steelwork below ground shall have 75mm concrete encasing with FGW41 wrapping centrally placed.
- U.N.O. beams and lintels to bear a minimum of 230mm on brickwork on a bed of 12mm of 2:1 sand / cement mortar.
- Masonry ties shall be welded to all steelwork in contact with masonry walls. U.N.O. use 3.25mm U shaped galvanised ties anchored 75mm into masonry at 400mm maximum cts.
- Provide pre-camber to steelwork as noted or specified.
- Provide all necessary cleats, holes etc. as required for fixing of timber and finishes to steelwork.
- U.N.O. all steelwork shall be thoroughly cleaned of rust, scale and grease and shall have one coat of red oxide zinc chromate primer except for concrete encased steelwork, galvanised steelwork, and mating steel surfaces connected together with 8.8/TF bolts. Priming is to be touched up on completion of erection. All exposed steelwork and external lintels shall be galvanised, (refer to details).

REV	DATE	DESCRIPTION
2	5.2.24	150 PLINTH ADDED

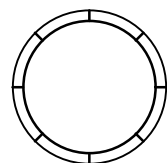

ORIENTATION

D O'BRIEN ENGINEERING SERVICES PTY. LTD.
 CONSULTING CIVIL & STRUCTURAL ENGINEERS
 A.C.N. 000 526 876

PH: (04)12 971 107

P.O. BOX 326 MANLY 1655
 Email: dobrieneng@optusnet.com.au

PROJECT

SCOREBOARD SIGNAGE

LOCATION

GAMES MORGAN RESERVE
 DEE WHY NSW

TITLE

SIGN FRAMING & DETAILS

DESIGNED

DOB

SCALE AS NOTED

DATE 5/2/24

DRG. No. 23012.S1

REV. 2