



WE SEE ARCHITECTURE AS  
A QUIET BUT POWERFUL MIX  
OF COLLABORATION AND  
CRAFT.

LET'S GET INTO IT.

## DVS+SEPP65+ADG REPORT

LOCATION

54-58 Beaconsfield  
St, Newport

DATE

December 2024

CLIENT

JAK NEWPORT PTY LTD

NOMINATED ARCHITECT

Paul Buljevic  
No. 7768

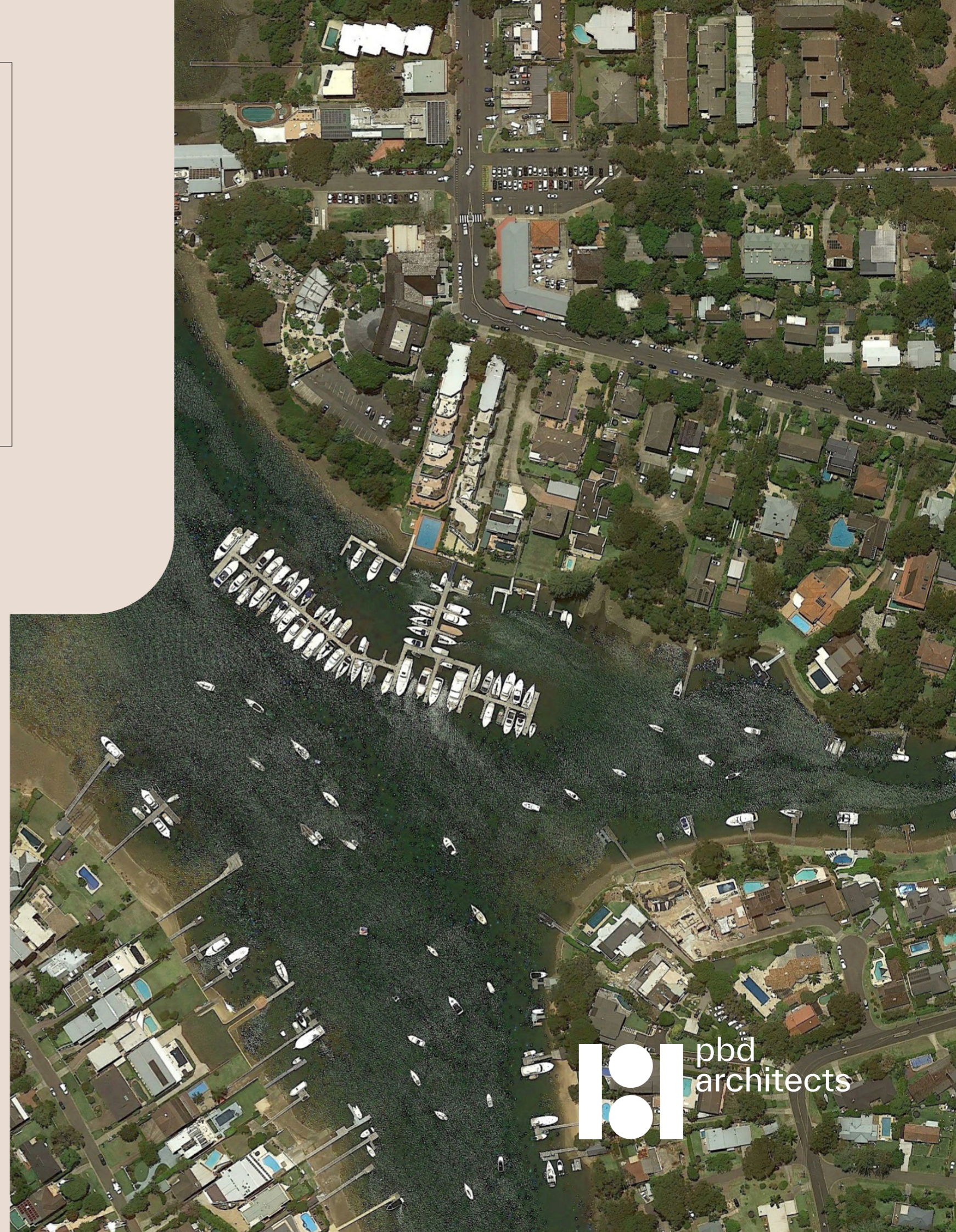

# DESIGN VERIFICATION STATEMENT

PBD Architects has been responsible for the design of the project since its inception and have worked with related professional and experts in respect of the matter. The project has been designed to provide a development that is respectful of local planning and design controls and that responds to the best practice design principles of SEPP No. 65. PBD Architects verify that the design quality principles set out in Schedule 1, Design quality principles of the State Environmental Planning Policy No. 65 – Design Quality of Residential Apartment Development are achieved for the proposed development described in the following document.



**Paul Buljevic**

**Managing Director**

**Registered Architect NSW, No. 7768**



## **PBD | Paul Buljevic Design**

Paul Buljevic is a Registered Architect in New South Wales and a member of the Australian Institute of Architects Registration number is 7768. He is a qualified Architect with extensive experience in the design of residential housing developments of varying scale. Paul Buljevic has been responsible for the design of this project since its inception and has worked with a professional consultant team in preparing the Development Application.

# CONTENTS

## 01. THE SITE

- : Site analysis
- : Proposal

## 02. INTRODUCTION

- : To Design Quality Principles
- : Proposal

## 03. PRINCIPLE 1

- : Context & Neighbourhood Character
- : Proposal

## 04. PRINCIPLE 2

- : Built Form & Scale
- : Proposal

## 05. PRINCIPLE 3

- : Density
- : Proposal

## 06. PRINCIPLE 4

- : Sustainability
- : Proposal

## 07. PRINCIPLE 5

- : Landscape
- : Proposal

## 08. PRINCIPLE 6,7 & 8

- : Amenity, Safety, Housing diversity & social Interaction
- : Proposal

## 09. PRINCIPLE 9

- : Aesthetics
- : Proposal

## 10. ADG REPORT

- : ADG - Response to Objectives
- : Proposal

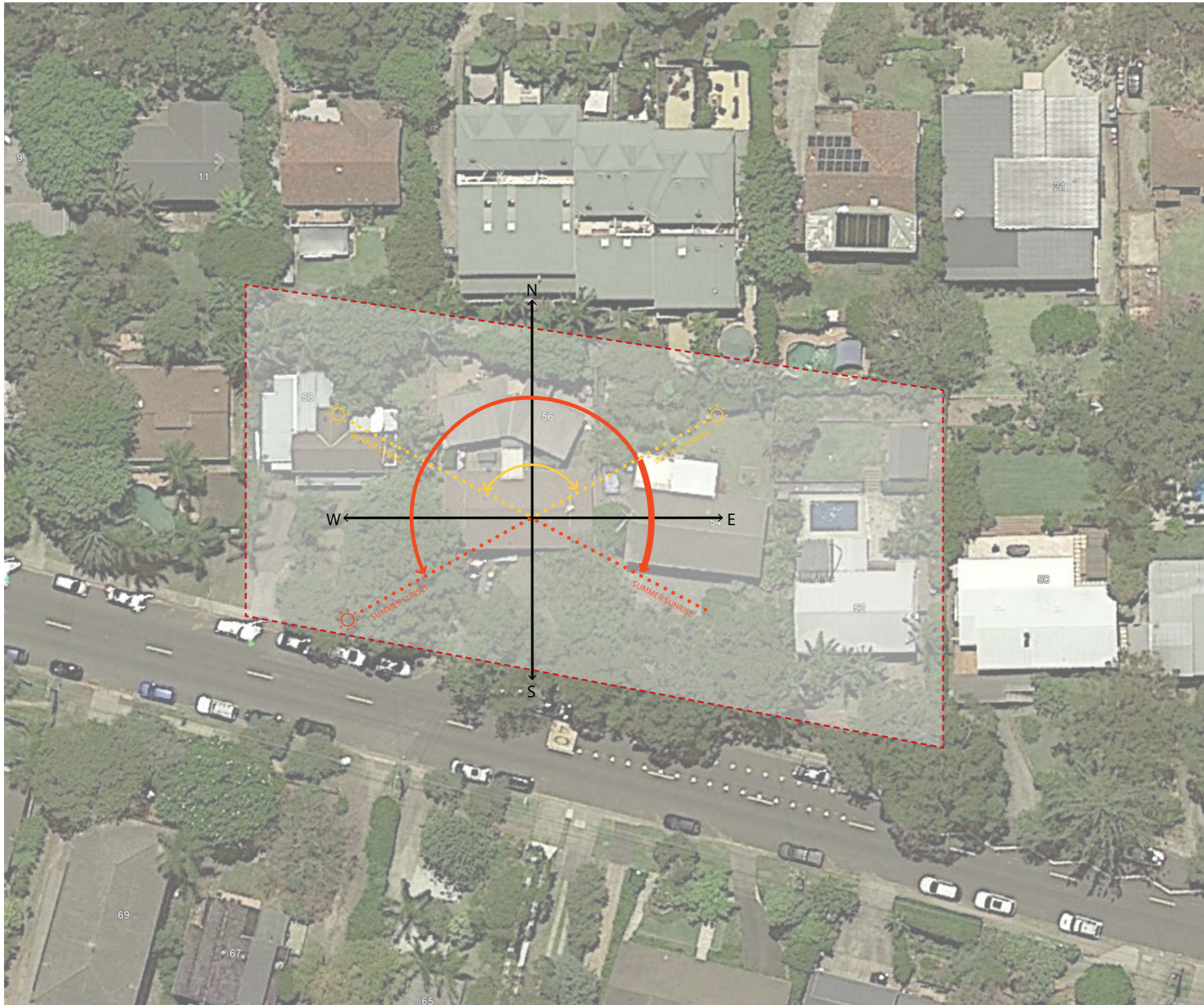

# THE SITE

54-58 BEACONSFIELD STREET |  
NEWPORT

The amalgamation of 3 allotments from 54 to 58 Beaconsfield Street creates a rectangular site of approx 2113.50m<sup>2</sup>. The site has one street frontage with a southern aspect along Beaconsfield street. The subject site is zoned in R3- Medium Density Zone with a maximum building height of 8.5m.

The site is located 350 meters from Newport Warf and is therefore well connected to amenities, facilities and public transport routes. This centrally located site is a great opportunity to develop and further improve the built environment in the area.

The surrounding context has seen some impressive developments come to fruition in the past decade, many of which have contributed to the character of the area.

The design is sympathetic to the pattern of development and desired future character of Newport.



# INTRODUCTION

## TO DESIGN QUALITY PRINCIPLES

*"The design quality principles for residential flat development are the principles set out in this Part. Good design is a creative process which, when applied to towns and cities, results in the development of great urban places: buildings, streets, squares and parks. Good design is inextricably linked to its site and locality, responding to the landscape, existing built form, culture and attitudes. It provides sustainable living environments, both in private and public areas. Good design serves the public interest and includes appropriate innovation to respond to technical, social, aesthetic, economic and environmental challenges. The design quality principles do not generate design solutions, but provide a guide to achieving good design and the means of evaluating the merit of proposed solutions."*

Source: State Environmental Planning Policy No 65 - Design Quality of Residential Flat Development under the Environmental Planning and Assessment Act 1979

## PROPOSAL

In this Report the proposal for 54-58 Beaconsfield Street is explained by using the Design Quality Principles listed in the State Environmental Planning Policy No 65 - Design Quality of Residential Flat Development under the Environmental Planning and Assessment Act 1979.

# PRINCIPLE 1

## CONTEXT & NEIGHBOURHOOD CHARACTER

"Good design responds and contributes to its context. Context can be defined as the key natural and built features of an area.

Responding to context involves identifying the desirable elements of a location's current character or, in the case of precincts undergoing a transition, the desired future character as stated in planning and design policies. New buildings will thereby contribute to the quality and identity of the area."

Source: State Environmental Planning Policy No 65 - Design Quality of Residential Flat Development under the Environmental Planning and Assessment Act 1979

## NEWPORT NEIGHBOURHOOD CHARACTER

Newport has seen some impressive developments come to fruition in the past decade. The desired future character can be seen by the overall high design standards, which on its turn has improved the face of Newport significantly.

The trend of these high design standards have been a key driver in the design process of the proposed development at 54-58 Beaconsfield Street, Newport. Furthermore, a contextual analysis has established a greater knowledge about the surrounding developments and their characteristics. The material palette, bulk and scale, form and architectural style has been displayed via the images on this page. The following observations can be made:

### Form and aesthetic

- sculptural form
- sharp angles vs curvature
- directional form orientation

### Bulk and Scale

- Monolithic volumes
- range of 2-4storeys
- open balconies

### Materiality

- Natural hues
- Raw and durable materials
- Contrast in warm and cold textures
- leafy streetscape with stone kerbs and a range of timber and metal fences.

The overall style is eclectic, however all developments are tied together with an overall Australian coastal style hanging above them.



60 BEACONSFIELD STREET



8A MITALA STREET



CASA PALOMA



48 BEACONSFIELD STREET



11-17 OCEAN AVENUE



50 BEACONSFIELD STREET

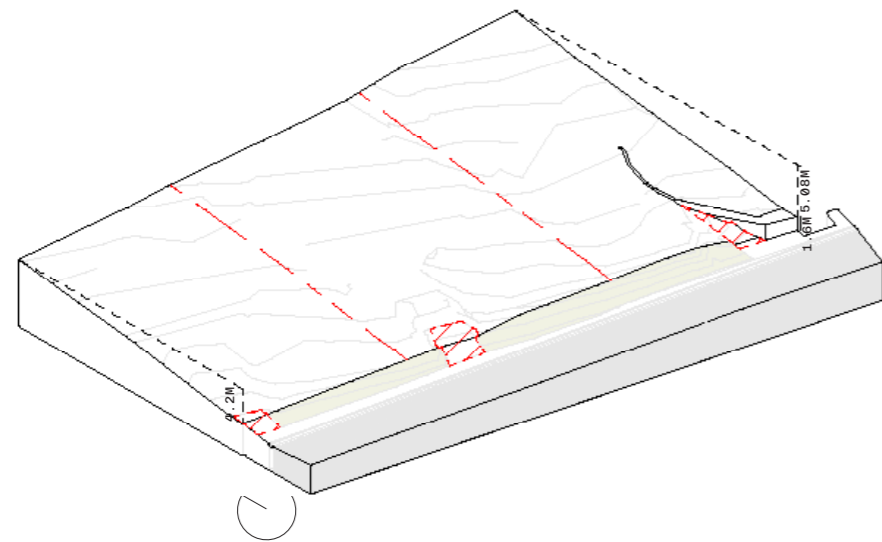

### 1. SITE CONDITIONS

- Gradual fall towards south-west

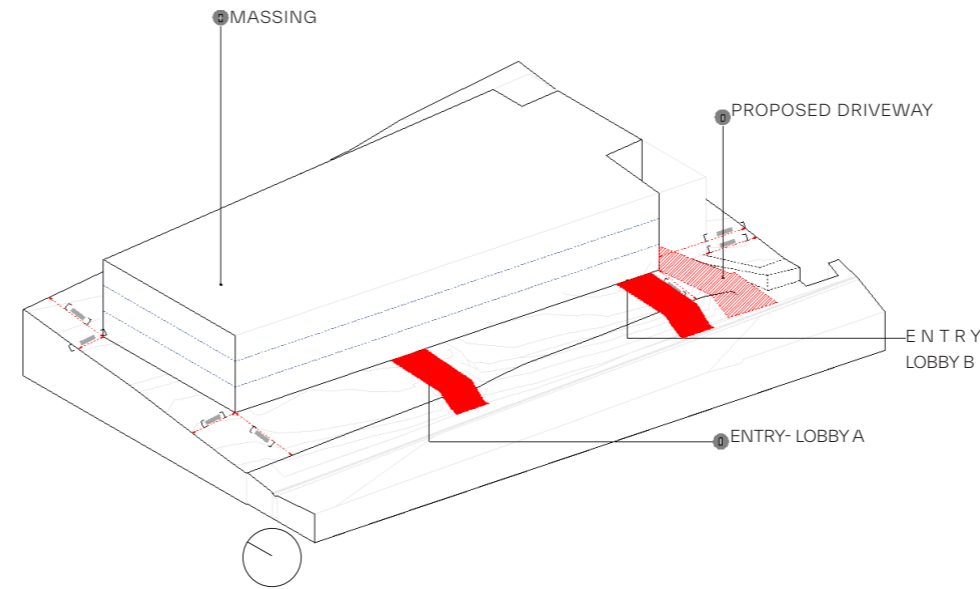

### 2. BUILDING ENVELOPE LAYOUT AND ORIENTATION

- Building envelope as per the setbacks
- Envelope to maintain neighbourhood privacy.
- Building arrangement features green courtyards and terraces.
- Rear and side setback to allow for deep soil and to minimised impact to adjacent properties.

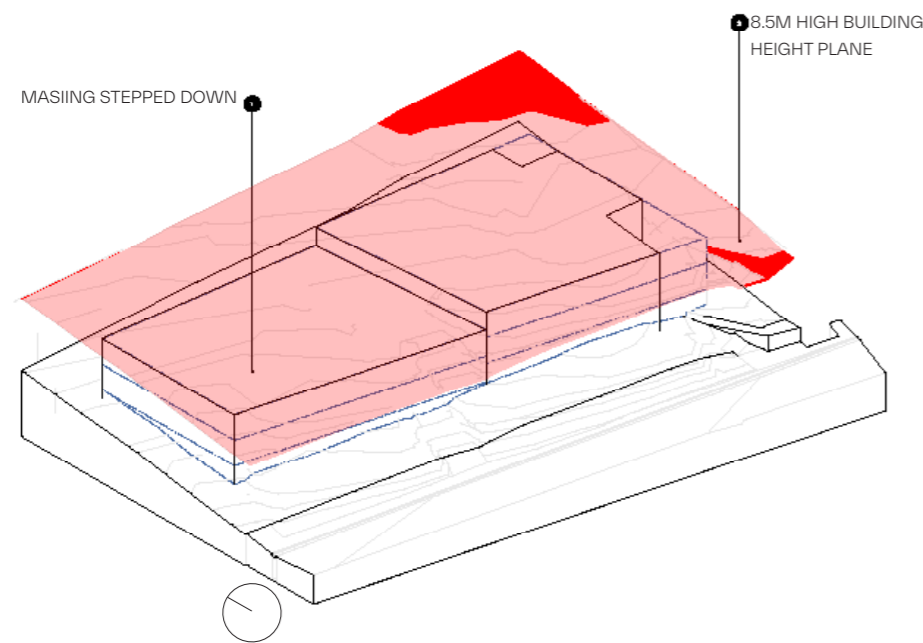

### 3. BUILT FORM SECTION

- The building form adapts to the natural ground level by pushing downwards to comply with the building height Plane

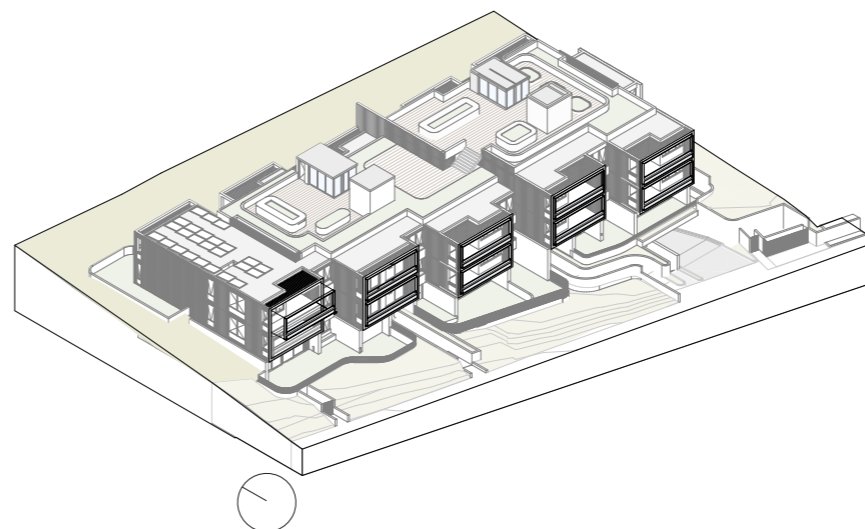

### 4. STREET FACADE

- Built form maintains consistent height across streetscape
- Substrate building form to create separations between units to enhance solar access.
- Three storey street interface with strategically layered facade.

# PRINCIPLE 2

## BUILT FORM & SCALE

"Good design provides an appropriate scale in terms of the bulk and height that suits the scale of the street and the surrounding buildings.

Establishing an appropriate scale requires a considered response to the scale of existing development. In precincts undergoing a transition, proposed bulk and height needs to achieve the scale identified for the desired future character of the area.

Good design achieves an appropriate built form for a site and the building's purpose, in terms of building alignments, proportions, building type and the manipulation of building elements.

Appropriate built form defines the public domain, contributes to the character of streetscapes and parks, including their views and vistas, and provides internal amenity and outlook."

Source: State Environmental Planning Policy No 65 - Design Quality of Residential Flat Development under the Environmental Planning and Assessment Act 1979

## BUILT FORM

The proposed building design has emerged from a careful consideration of the existing site conditions. The form articulation has been designed to maximise the solar orientation and privacy to adjacent properties. The general massing adapts to the natural ground level by pushing downwards thus, creating two different levels with two entry points to the individual core.

The bulk and scale of the development is in good proportion with the adjacent developments. Therefore, allowing to minimize the solar impact to adjacent properties.

Orientation of balconies towards the rear northern side create a high level of solar amenity to the units as well as creating a unique design in both elevation as well as in plan.

Building articulations are evident in the facade design, including the interplay of building plan and material selection to break down the volume to provide strength and bring the whole facade together.



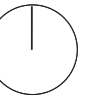

# PRINCIPLE 3

## DENSITY

"Good design has a density appropriate for a site and its context, in terms of floor space yields (or number of units or residents).

Appropriate densities are sustainable and consistent with the existing density in an area or, in precincts undergoing a transition, are consistent with the stated desired future density. Sustainable densities respond to the regional context, availability of infrastructure, public transport, community facilities and environmental quality."

Source: State Environmental Planning Policy No 65 - Design Quality of Residential Flat Development under the Environmental Planning and Assessment Act 1979

## PROPOSAL

There is a total of 13 apartments in the development, comprising of 13-3 bed Units. The apartments are generous in size in line with the apartment sizes within the area.

The proposal also reflects current market demands in relation to typologies and living patterns currently established in the local area.

The density of the development is considered sustainable within the existing and future availability of infrastructure, public transport, community and culturally significant facilities and environmental qualities on the site.

As such the proposal provides an appropriate density for a residential development in the immediate context.

The bulk and scale and it's density fits within the surrounding context and will contribute rather than burden the precinct.

The provided carpark, and bicycle provisions are as per the DCP maximum requirements.

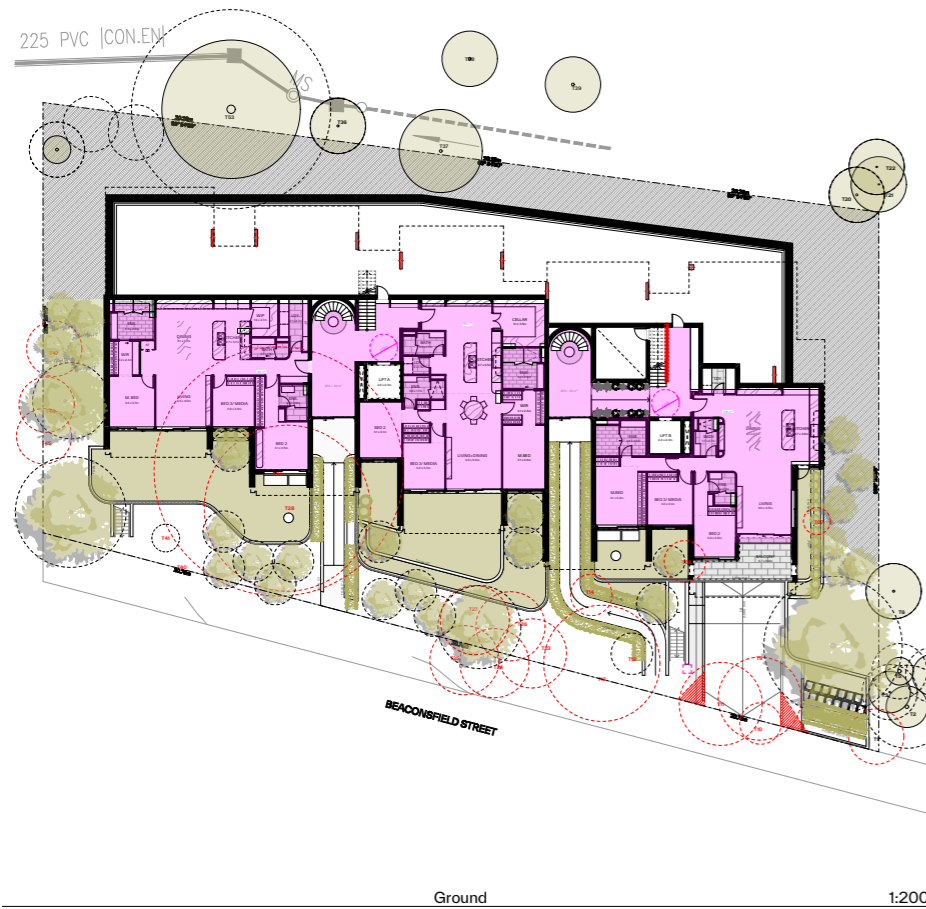

Ground 1:200



First Floor 1:200

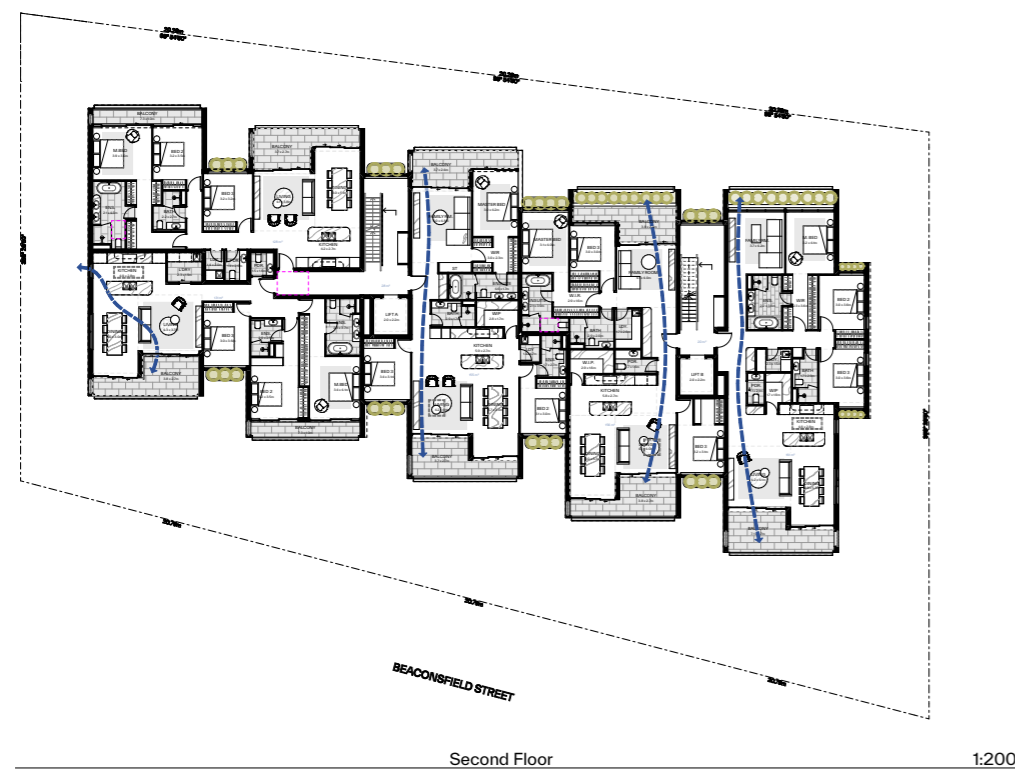
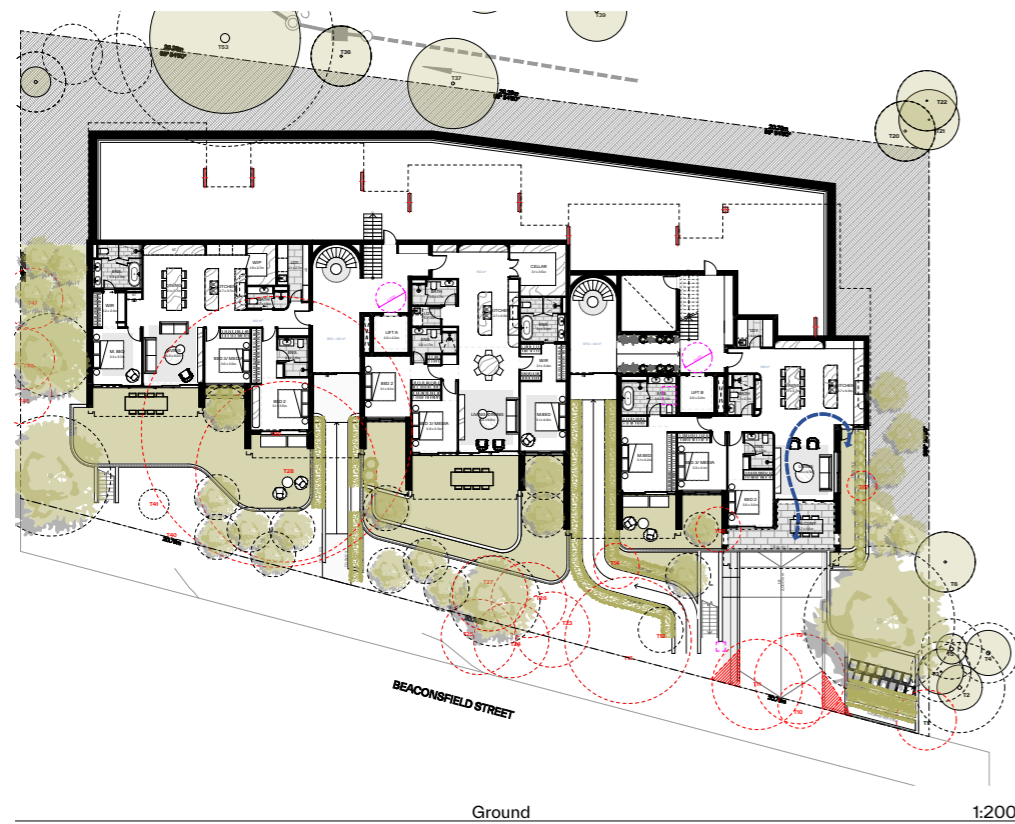
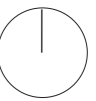

LEGEND:  
 ■ NATURALLY CROSS VENTILATED APARTMENTS

NATURAL VENTILATION CALCULATIONS

APARTMENT DESIGN GUIDE  
 - ALL HABITABLE ROOMS ARE NATURALLY VENTILATED  
 - AT LEAST 60% OF APARTMENTS ARE NATURALLY CROSS VENTILATED

TOTAL NUMBER OF APARTMENTS- 13 UNITS  
 NATURALLY VENTILATED APARTMENTS- 9 UNITS (69%)

# PRINCIPLE 4

## SUSTAINABILITY

"Good design makes efficient use of natural resources, energy and water throughout its full life cycle, including construction.

Sustainability is integral to the design process. Aspects include demolition of existing structures, recycling of materials, selection of appropriate and sustainable materials, adaptability and reuse of buildings, layouts and built form, passive solar design principles, efficient appliances and mechanical services, soil zones for vegetation and reuse of water."

Source: State Environmental Planning Policy No 65 - Design Quality of Residential Flat Development under the Environmental Planning and Assessment Act 1979

## PROPOSAL

A comprehensive analysis of the building has been undertaken as part of the BASIX Assessment however we note the following general design solutions and inclusions as part of the proposal:

The apartments are designed to ensure adequate access to daylight in the winter months. Furthermore 76% of the apartments receive over 2hrs of solar access in mid winter.

Cross flow ventilation has been maximised when possible. Appropriate overhang depths and recessed balconies provide shade in summer and promote thermal heat gain during winter months.

Energy efficient appliances and fixtures provided, low maintenance, long lifecycle and reusable materials proposed.

Communal recycling and waste management facilities are provided for on-site rainwater detention and re-use.



# PRINCIPLE 5

## LANDSCAPE

"Good design recognises that together landscape and buildings operate as an integrated and sustainable system, resulting in greater aesthetic quality and amenity for both occupants and the adjoining public domain.

Landscape design builds on the existing site's natural and cultural features in responsible and creative ways. It enhances the development's natural environmental performance by co-ordinating water and soil management, solar access, micro-climate, tree canopy and habitat values. It contributes to the positive image and contextual fit of development through respect for streetscape and neighbourhood character, or desired future character.

Landscape design should optimise useability, privacy and social opportunity, equitable access and respect for neighbours' amenity, and provide for practical establishment and long term management."

Source: State Environmental Planning Policy No 65 - Design Quality of Residential Flat Development under the Environmental Planning and Assessment Act 1979

## PROPOSAL

A close collaboration with renowned landscape architect Wyer & Co. has resulted in a synthesis of building design and it's natural surroundings.

The landscape proposal draws upon the unique ecological character of the Newport area, presenting a planting aesthetic both on the building facade (trough the use of planter boxes) and on ground floor that has a consistent language and connection with the existing local native environment.

The use of a predominantly native planting palette allows a gentle softening of the building footprint around the perimeters into the wider streetscape.

For further information refer to Wyer & Co. Landscape design report.

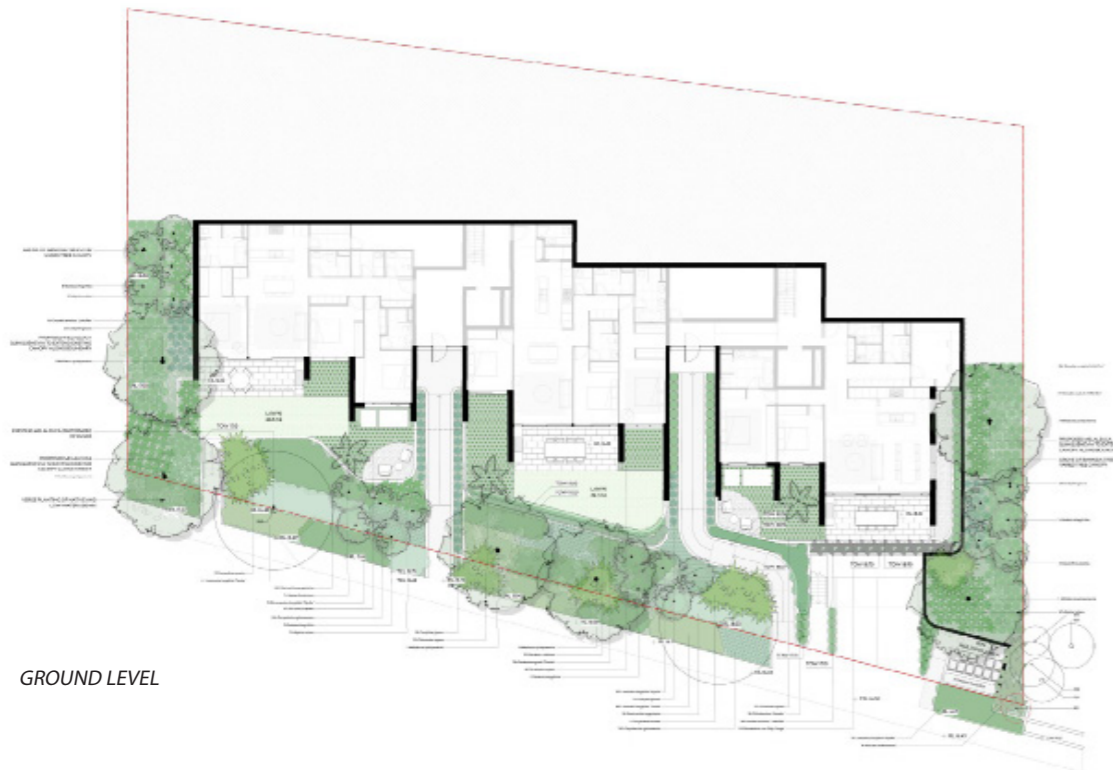

GROUND LEVEL

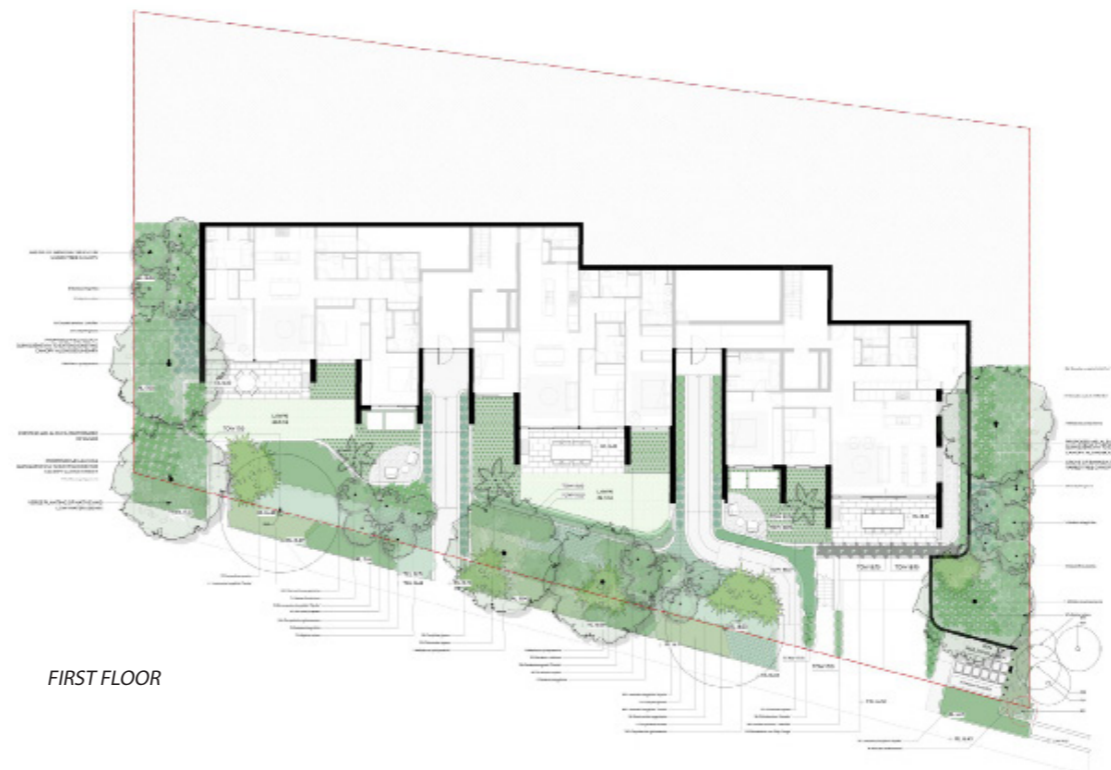

FIRST FLOOR



ROOF LEVEL

### LANDSCAPE DEVELOPMENT APPLICATION PLANS

#### COUNCIL REQUIREMENTS - NORTHERN BEACHES COUNCIL

THE LANDSCAPE PLAN IS IN GENERAL ACCORDANCE WITH COUNCIL PLANNING CONTROLS:  
• PITTWATER 21 DEVELOPMENT CONTROL PLAN  
• PITTWATER LOCAL ENVIRONMENTAL PLAN 2014  
• PITTWATER NATIVE GARDENING BOOKLET - PART 5 - ROLLING HILLS 7 LOWER S1 HALE SLOPES  
• APARTMENT DESIGN GUIDELINES (ADG) 2015

#### CONTROLS

CANOPY TREES REQUIRED TO BE NATIVE SPECIES:  
COUNCIL CONTROL = 100%  
PROPOSED = 100%

ALL OTHER PLANTS REQUIRED TO BE NATIVE SPECIES:  
COUNCIL CONTROL = 50%

ALL OTHER PROPOSED AUSTRALIAN NATIVE SPECIES = 12 / 20  
60% OF ALL OTHER TOTAL PROPOSED PLANT SPECIES

ALL OTHER PROPOSED AUSTRALIAN NATIVES  
BY QUANTITY = 4283 / 5316  
80.5% OF ALL OTHER PROPOSED QUANTITY

LANDSCAPE AREA / DEEP SOIL REQUIREMENTS:  
REFER TO ARCHITECTS DRAWINGS

ABORICULTURAL ASSESSMENT  
REFER TO ABORICULTURAL IMPACT ASSESSMENT REPORT PREPARED BY  
"F21 GROW" CONSULTANTS

#### LANDSCAPE INSTALLATION SPECIFICATION

##### PLANTER BEDS

- Minimum soil depths and volume for planting on any structure as per ADG:
- Large Trees (2-4m High) 200mm / 50m<sup>3</sup>
- Medium Trees (8-12m High) 1000mm / 35m<sup>3</sup>
- Small Trees (6-8m High) 800mm / 9m<sup>3</sup>
- Shrubs 500 - 600mm
- Groundcovers 300 - 450mm
- Turf 200mm

- Suitable drainage implemented through use of g g lines, drainage flow cell and geotech fabric.
- Soil to be ANL Planter Box Mix, or equivalent. Blend of soil, coarse sand, graded osh, nepean sand, composted swivel, battery humus and composted pine bark.
- Soil to be between 20-50mm below top of retaining wall height to allow for dropping.

##### TURFING

- Turf to be laid on minimum 100mm turf underlay.
- Turf underlay to be ANL Sand / Soil Blend, or equivalent.
- Turf to be Sir Walter Turf - Premium Buffalo Grass (Registered PBR), supplied by President Turf, or equivalent.

##### MULCHING

- Place mulch to minimum depth of 75mm, clear of plant stems, and rake to an even surface flush with the surrounding finished levels and consistent in depth.
- Trees in lawn areas to have 750mm diameter of mulch surrounding.
- Mulch for general garden areas, pots, and planters to be Australian Native Landscapes (ANL) Greenlife Mulch and Compost, or equivalent.

##### TREE PLANTING

- Excavate holes in accordance with dimension of container. The depth of the holes is to be equivalent to the container height plus 100mm and the width of the hole is to be twice that of the container.
- Locate tree to centre of hole and backfill with soil. Firm about root ball.
- All plant material, 45% trees or more, to be stated.

##### IRRIGATION

- Automated irrigation system to be implemented. Reputable irrigation brands are to be sourced.
- Use drip lines with emitters of 300mm spacing's for all garden beds.
- Use pop-up spray heads for all lawn areas. Pop-up spray heads are to be spaced according to product specification.
- Conceal irrigation below the mulch layer in planting areas and 150mm below the surface of turf areas. Conceal all components including pipework, fittings, valves, and control equipment.

# WYER & CO

# PRINCIPLE 6

## AMENITY

"Good design provides amenity through the physical, spatial and environmental quality of a development.

Optimising amenity requires appropriate room dimensions and shapes, access to sunlight, natural ventilation, visual and acoustic privacy, storage, indoor and outdoor space, efficient layouts and service areas, outlook and ease of access for all age groups and degrees of mobility."

Source: State Environmental Planning Policy No 65 - Design Quality of Residential Flat Development under the Environmental Planning and Assessment Act 1979

## PROPOSAL

Generous apartment sizes and general configuration consistent with ADG objectives. All apartments have compliant private open space balconies or terraces.

The northern facing balconies enjoy solar shading from the terraces and balconies above. The building layout allows the access to direct sunlight to living areas and balconies to total of 10 Units(76%) achieving min. 2hr solar access.

All bedrooms and habitable spaces are naturally ventilated, and 69% of the apartments achieve cross ventilation.

The balconies are appropriately located to maintain privacy and minimise the transmission of noise between apartments. Party walls between apartments are limited and are appropriately insulated.

# PRINCIPLE 7

## SAFETY

"Good design optimises safety and security, both internal to the development and for the public domain.

This is achieved by maximising overlooking of public and communal spaces while maintaining internal privacy, avoiding dark and non-visible areas, maximising activity on streets, providing clear, safe access points, providing quality public spaces that cater for desired recreational uses, providing lighting appropriate to the location and desired activities, and clear definition between public and private spaces."

Source: State Environmental Planning Policy No 65 - Design Quality of Residential Flat Development under the Environmental Planning and Assessment Act 1979

## PROPOSAL

The entrance will be clearly visible from the street with a secure access and intercom to identify visitors to the building complex.

All apartments are with a keyed system incorporating a high level of occupant safety. Residential apartments facing the street/public areas will offer passive surveillance to the street.

A secure basement carpark is provided with keyed and remote-control access. Clear circulation paths in the basement allow safe pedestrian movement to individual parking spaces and storage area.

Clear delineation between private and public accessible space by the introduction of planter walls, fences & gates.

# PRINCIPLE 8

## HOUSING DIVERSITY & SOCIAL INTERACTION

"Good design responds to the social context and needs of the local community in terms of lifestyles, affordability, and access to social facilities.

New developments should optimise the provision of housing to suit the social mix and needs in the neighbourhood or, in the case of precincts undergoing transition, provide for the desired future community. New developments should address housing affordability by optimising the provision of economic housing choices and providing a mix of housing types to cater for different budgets and housing needs."

Source: State Environmental Planning Policy No 65 - Design Quality of Residential Flat Development under the Environmental Planning and Assessment Act 1979

## PROPOSAL

The size, configuration and mix of the apartments associated with the development provides an appropriate response to the market demand of future occupants, catering for a high demand in owner occupiers. A proportion of apartments is target towards a mid to high socio-economic group which can be facilitated given the growth and development of the area.

As set out in the Apartment Design Guide, min. 20% of the units are designed to Silver Level –Livable Housing Code with minimum retrofit at a later stage. In addition, the development has also provided generous width of lobbies for ease of accessibility.

The site is located within close proximity to necessary facilities including public transport, supermarkets, educational and leisure facilities as well as schools.

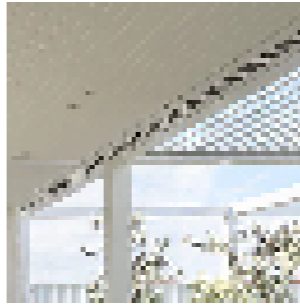
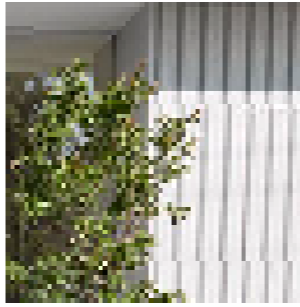
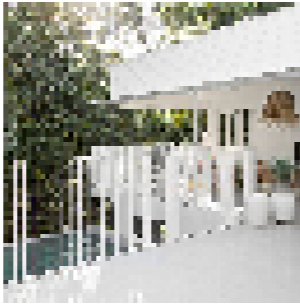
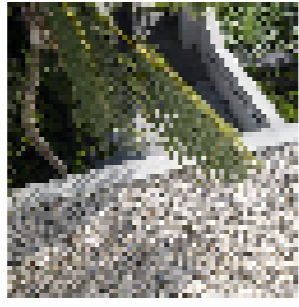
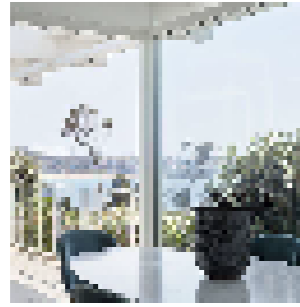

# PRINCIPLE 9

## AESTHETICS

"Quality aesthetics require the appropriate composition of building elements, textures, materials and colours and reflect the use, internal design and structure of the development.

Aesthetics should respond to the environment and context, particularly to desirable elements of the existing streetscape or, in precincts undergoing transition, contribute to the desired future character of the area."

Source: State Environmental Planning Policy No 65 - Design Quality of Residential Flat Development under the Environmental Planning and Assessment Act 1979

## PROPOSAL

Massing and façade details are designed to respond to both desired character of the area and the existing context.

Considering the materiality study of surrounding new developments the proposal features a restrained palette of off-form concrete and stone finished walls, as well as weatherboard cladding for the upper floor.

The elevations are modulated in expression and designed primarily to respond to sun, views, setbacks and the site. The building has a sculptural form and unique aesthetic, tempered by environmental controls, site response and landscape elements.

Colour and material selections have been made to create transitions between inside and outside and allowing the development to enhance its surrounding neighbourhood.

All materials selected will be durable and hard wearing so the development does not prematurely age. This will enhance the long-term image of the building with its careful composition of building elements, textures, materials, colours, internal design and structure contributing positively to the desired future character of the vicinity.

The overall design and choice of materials is a suitable addition to the character of the neighbourhood. It creates a quality addition to the versatile building fabric in Newport.

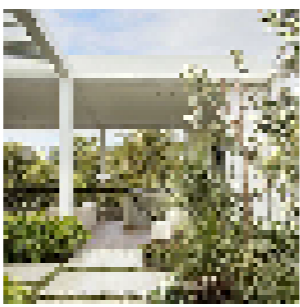
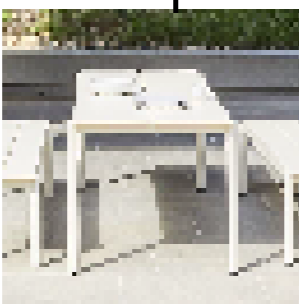

### **Objective 3A-1**

Site Analysis illustrates that design decisions have been based on opportunities and constraints of the site conditions and their relationship to the surrounding context.

Proposed: The proposal seeks the opportunity to combine 3 allotments for the development. The overall street presence along 54-58 Beaconsfield street will be in line with the future precinct character.

### **Objective 3B-1**

Building types and layouts respond to the streetscape and site while optimising solar access within the development.

Proposed: The orientation of the proposal retains and addresses the existing street orientation with further consideration in response to the northern aspect. The living areas in each apartment have been carefully located to maximise solar and daylight access.

### **Objective 3B-2**

Overshadowing of neighbouring properties is minimised during mid-winter.

Proposed: The building forms have been informed by the objectives of the building envelope controls outlined of the DCP and the ADG. The proposal is generally compliant with the height limit. The side setbacks, the rear overcompliance with the height plane and the sculpting of the building form minimise overshadowing to the neighboring properties

### **Objective 3C-1**

Transition between private and public domain is achieved without compromising safety and security

Proposed: Residential access point is carefully and appropriately located for legibility to residents and visitors; the main residential lobby is designed with secured access to appropriately separate circulation routes.

### **Objective 3C-2**

Amenity of the public domain is retained and enhanced

Proposed: Generous landscaping has been carefully designed to ensure privacy for the apartments on ground floor. The car-park entry has been positioned with clear sight lines for front exiting cars. Durable materials are used through-out the public domain.

### **Objective 3D-1**

An adequate area of communal open space is provided to enhance residential amenity and to provide opportunities for landscaping.

Proposed: Total 528 (25%) of the site area has been proposed. COS on the roof top is provided with BBQ, seating area and relaxing nook with table and seats

### **Objective 3D-2**

Communal open space is designed to allow for a range of activities, respond to site conditions and be

attractive and inviting

Proposed: Proposed, same as 3D-1. Additionally COS maximising the building's integration with its natural surroundings and providing a desirable living experience.

### **Objective 3D-3**

Communal open space is designed to maximise safety

Proposed: Provided and is readily visible by the residents. COS on rooftop will be carefully lit at night to foster safety.

### **Objective 3D-4**

Public open space, where provided, is responsive to the existing pattern and uses of the neighbourhood

Proposed: N/A

### **Objective 3E-1**

Deep soil zones provide areas on the site that allow for and support healthy plant and tree growth. They improve residential amenity and promote management of water and air quality

Proposed: The proposal includes 1123.3m<sup>2</sup> of deep soil zone (53% of the Site area) in a pursuit to comply with the Pittwater DCP.

### **Objective 3F-1**

Adequate building separation distances are shared equitably between neighbouring sites, to achieve reasonable levels of external and internal visual privacy

Proposed: The proposed setbacks are consistent with the ADG/DCP requirements. Window location and orientation has been carefully designed to ensure visual privacy.

### **Objective 3F-2**

Site and building design elements increase privacy without compromising access to light and air and balance outlook and views from habitable rooms and private open space

Proposed: Balconies are located in front of living areas to increase internal privacy. Balcony articulations, Landscape are multipurposed in providing privacy whilst enhancing living environments.

### **Objective 3G-1**

Building entries and pedestrian access connects to and addresses the public domain

Proposed: Main entry creates a clearly defined private and public domain.

### **Objective 3G-2**

Access, entries and pathways are accessible and easy to identify

Proposed: Access designed in accordance with required standards.

### **Objective 3G-3**

Large sites provide pedestrian links for access to streets and connection to destinations

Proposed: N/A

### **Objective 3H-1**

Vehicle access points are designed and located to achieve safety, minimise conflicts between pedestrians and vehicles and create high quality streetscapes

Proposed: Single vehicular crossing provided to minimise any overlap with pedestrian footpath. Pedestrian and vehicular access points are separate and distinguishable.

### **Objective 3I-1**

Car parking is provided based on proximity to public transport in metropolitan Sydney and centres in regional areas.

Proposed: The proposed basement car parking is provided in accordance with traffic engineers calculations and complies with the specified under the current DCP/LEP.

### **Objective 3I-2**

Parking and facilities are provided for other modes of transport.

Proposed: Bicycle and motorbike parking is provided at rates recommended by the traffic report for residents and visitors, to encourage this mode of transport.

### **Objective 3I-3**

Car park design and access is safe and secure.

Proposed: Car park access is secured at appropriate levels for amenity and residential uses. Clearly defined and visible waiting areas are provided to lifts and stairs. Lighting, signage, line markings and bollards will be included in the car park design.

### **Objective 3I-4**

Visual and environmental impacts of underground car parking are minimised

Proposed: Vehicular Entry node at South-East corner of site. Excavation is minimised through efficient car park layouts and ramp design. Car park layout is well organised and uses a logical structural grid. Car parking is located entirely below ground.

### **Objective 3I-5**

Visual and environmental impacts of on-grade car parking is minimised

Proposed: No long term on-grade parking is proposed.

### **Objective 3I-6**

Visual and environmental impacts of above ground enclosed car parking are minimised

Proposed: The proposal does not provide above ground parking.

### **Objective 4A-1**

To optimise the number of apartments receiving sunlight to habitable rooms, primary windows and private open space.

ADG: Living rooms and private open spaces of at least 70% of apartments in a building receive a minimum of 2 hours direct sunlight between 9 am and 3 pm at mid-winter  
Proposed: 76% (10/13) of the apartments receive a minimum of 2 hours of sunlight to living rooms that over achieve the ADG recommendation.

### **Objective 4A-2**

Daylight access is maximised where sunlight is limited

Proposed: Building envelopes have been developed to minimise the quantity of apartments with no direct sunlight midwinter. Skylight windows are used as secondary light source to habitable rooms. Opportunities for reflected light are maximised by providing light coloured internal finishes.

### **Objective 4A-3**

Design incorporates shading and glare control, particularly for warmer months.

Proposed: The extent of balconies provides shading from summer sun to living areas. Balconies on north facades sit within the building envelope for shading in summer and weather protection.

### **Objective 4B-1**

All habitable rooms are naturally ventilated.

Proposed: Windows and doors are provided to allow the ADG and BCA requirements for natural ventilation.

### **Objective 4B-2**

The layout and design of single aspect apartments maximises natural ventilation

Proposed: The layout and design of single aspect apartments maximises natural ventilation.

### **Objective 4B-3**

The number of apartments with natural cross ventilation is maximised to create a comfortable indoor environment for residents

Proposed: 9/13 apartments (69%) are naturally cross ventilated.

### **Objective 4C-1**

Ceiling height achieves sufficient natural ventilation and daylight access

Proposed: All apartments achieve sufficient daylight access and natural ventilation; A minimum floor-to-floor height of 3.1m is achieved to allow the ADG recommendation of 2.7m ceiling height to generally be achieved in living, dining and bedroom areas.

# ADG

## RESPONSE TO ADG OBJECTIVES

"The following provides a design response to the relevant objectives of the Apartment Design Guide (ADG) and describes the measures by which the proposed development meets these objects."

Source: State Environmental Planning Policy No 65 - Design Quality of Residential Flat Development under the Environmental Planning and Assessment Act 1979.

### **Objective 4C-2**

Ceiling height increases the sense of space in apartments and provides for well-proportioned rooms

Proposed: Internal layouts have well proportioned rooms with good access to daylight and ventilation, to maximise the feeling of spaciousness.

### **Objective 4C-3**

Ceiling heights contribute to the flexibility of building use over the life of the building

Proposed: Every floor to floor conforms with the ADG, with 2700mm to habitable rooms and 2400mm to non-habitable rooms.

### **Objective 4D-1**

The layout of rooms within an apartment is functional, well organised and provides a high standard of amenity

Proposed: The proposed minimum apartment sizes are as follows:  
85-100m<sup>2</sup> for 2 bedroom apartments  
140m<sup>2</sup> for 3 bedroom apartments;  
All habitable rooms have large windows to external walls that bring in daylight.

### **Objective 4D-2**

Environmental performance of the apartment is maximised.

Proposed: Refer to Objective 4C-1 for ceiling heights.

### **Objective 4D-3**

Apartment layouts are designed to accommodate a variety of household activities and needs  
Proposed: Minimum areas and widths of habitable rooms are provided or exceeded where possible. Access to bedrooms, bathrooms and laundries is generally separated from living areas minimising direct openings between living and service areas.

**Objective 4C-2**

*Ceiling height increases the sense of space in apartments and provides for well-proportioned rooms*

Proposed: Internal layouts have well proportioned rooms with good access to daylight and ventilation, to maximise the feeling of spaciousness.

**Objective 4C-3**

*Ceiling heights contribute to the flexibility of building use over the life of the building*

Proposed: Every floor to floor conforms with the ADG, with 2700mm to habitable rooms and 2400mm to non-habitable rooms.

**Objective 4D-1**

*The layout of rooms within an apartment is functional, well organised and provides a high standard of amenity*

Proposed: The proposed minimum apartment sizes are as follows:  
130-160m<sup>2</sup> for 3 bedroom apartments;  
All habitable rooms have large windows to external walls that bring in daylight.

**Objective 4D-2**

*Environmental performance of the apartment is maximised.*

Proposed: Refer to Objective 4C-1 for ceiling heights.

**Objective 4D-3**

*Apartment layouts are designed to accommodate a variety of household activities and needs*

Proposed: Minimum areas and widths of habitable rooms are provided or exceeded where possible. Access to bedrooms, bathrooms and laundries is generally separated from living areas minimising direct openings between living and service areas.

**Objective 4E-1**

*Apartments provide appropriately sized private open space and balconies to enhance residential amenity*

Proposed: All apartments are provided with balconies that Comply with the minimum requirement and the appropriate depth.

**Objective 4E-2**

*Primary private open space and balconies are appropriately located to enhance liveability for residents*

Proposed: Balconies are always located adjacent to living and dining rooms to extend these spaces.

**Objective 4E-3**

*Private open space and balcony design is integrated into and contributes to the overall architectural form and detail of the building*

Proposed: The balconies are an integral part of the building facade design, this forms an integral part of the architectural expression of the building. balconies are designed to act as natural extensions

The balconies are designed to act as natural extensions of the living areas.

**Objective 4E-4**

*Private open space and balcony design maximises safety.*

Proposed: Design and detailing of balconies avoid opportunities for climbing and falls.

**Objective 4F-1**

*Common circulation spaces achieve good amenity and properly service the number of apartments*

Proposed: The maximum number of apartments served by a single  
Lift is 3. Shared lobby provide easy access from street level.

**Objective 4F-2**

*Common circulation spaces promote safety and provide for social interaction between residents*

Proposed: Common circulation spaces are designed to provide safe, legible spaces to foster interaction and harmony between residents.

**Objective 4G-1**

*Adequate, well-designed storage is provided in each apartment*

Proposed: A variety of storage types are provided, accessed off living rooms and circulation corridors within the apartments, in joinery units, storage and study areas. Storage locations are allocated within basement levels as part of the proposal. Basement storage zones available meet ADG requirements.

**Objective 4G-2**

*Additional storage is conveniently located, accessible and nominated for individual apartments*

Proposed: Storage cages are provided in basement levels and allocated to specific apartments.

**Objective 4H-1**

*Noise transfer is minimised through the siting of buildings and building layout*

Proposed: The balconies are appropriately located to minimise the transmission of noise between apartments, particularly at the internal corners. Windows and door openings are generally oriented away from noise sources. Party walls between apartments are limited and are appropriately insulated.

**Objective 4H-2**

*Noise impacts are mitigated within apartments through layout and acoustic treatments*

Proposed: Facades and glazing systems have been carefully considered.

**Objective 4J-1**

*In noisy or hostile environments, the impacts of external noise and pollution are minimised through*

*the careful siting and layout of buildings*

Proposed: All habitable rooms facing the street are generally setback to mitigate traffic noises.

**Objective 4J-2**

*Appropriate noise shielding or attenuation techniques for the building design, construction and choice of materials are used to mitigate noise transmission*

Proposed: Landscaping proposed to assist in diffusing noise transmission. Further acoustic analysis will be conducted during design development.

**Objective 4K-1**

*A range of apartment types and sizes is provided to cater for different household types now and into the future*

Proposed: 13x 3 bed apartments are proposed, representing an appropriate mix for the urban context.

Apartment layouts are capable of accommodating first home buyers, investors young families and professionals.

**Objective 4K-2**

*The apartment mix is distributed to suitable locations within the building*

Proposed: The apartment types are distributed appropriately throughout the building.

**Objective 4L-1**

*Street frontage activity is maximised where ground floor apartments are located*

Proposed: Ground floor apartments have external courtyard facing the street to promote activity along the street.

**Objective 4L-2**

*Design of ground floor apartments delivers amenity and safety for residents*

Proposed: Private open spaces are landscaped with integrated fences for additional safety.

**Objective 4M-1**

*Building facades provide visual interest along the street while respecting the character of the local area*

Proposed: Materials have been selected in response to the local and immediate context. The proposal fits within the Newport predominant development style.

**Objective 4M-2**

*Building functions are expressed by the façade*

Proposed: Main building entry expressed by indentations in the front façade and landscape strip leading to these entries. All elevations are rationally designed and respond to their use.

**Objective 4N-1**

*Roof treatments are integrated into the building*

**Objective 4N-1**

*Roof treatments are integrated into the building design and positively respond to the street.*

Proposed: The proposed roof design in an unobstructive flat roof with proposed landscaping space.

**Objective 4N-2**

*Opportunities to use roof space for residential accommodation and open space are maximised*

Proposed: Rooftop access by residents has been provided within the proposed rooftop communal open design.

**Objective 4N-3**

*Roof design incorporates sustainability features*

Proposed: Roof design maximises solar access to apartments during winter and provides shade during summer via overhanging roofs and planting; Skylights are provide for additional solar access.

**Objective 4O-1**

*Landscape design is viable and sustainable*

Proposed: Building performance is enhanced by incorporating a diverse planting including appropriately planted shading trees and street trees to meet DCP requirements.

**Objective 4O-2**

*Landscape design contributes to the streetscape and amenity*

Proposed: The proposal involves an improvement to the public domain with additional canopies tree proposed along Beaconsfield street.

**Objective 4P-1**

*Appropriate soil profiles are provided.*

Proposed: The Northern end of the site provides much of the required deep soil for tree planting. Raised planters are provided on residential level balconies. Planter box on the roof are minimum 800mm deep as per the DCP requirement.

**Objective 4P-2**

*Plant growth is optimised with appropriate selection and maintenance*

Proposed: Diverse planting that are low in maintenance and suited to the site are incorporated to enhance the performance of the landscaped areas.

**Objective 4P-3**

*Planting on structures contributes to the quality and amenity of communal and public open spaces*

Proposed: Planting is positioned on main facade for visibility from the public domain. The design proposes significant planting on the ground level and to the rear units on first floor. Refer to Landscape plan.

**Objective 4Q-1**

*Universal design features are included in apartment design to promote flexible housing for all community members*

Proposed: Apartments are open plan in design providing a free-flowing living environment with generous open space for occupant flexibility.s.

**Objective 4Q-2**

*A variety of apartments with adaptable designs are provided Adaptable housing should be provided in accordance with the relevant council policy*

Proposed: Silver level- Livable units are provided to meet the DCP requirement: convenient access to public areas, high level of solar access, minimal structural change and residential amenity loss when adapted, larger car parking spaces for accessibility, parking titled separately, Refer to Access Report for further information.

**Objective 4Q-3**

*Apartment layouts are flexible and accommodate a range of lifestyle needs*

Proposed: All apartments have open plan living allowing flexibility on the use.

**Objective 4R-1**

*New additions to existing buildings are contemporary and complementary and enhance an area's identity and sense of place*

Proposed: There are no additions to existing buildings provided.

**Objective 4R-2**

*Adapted buildings provide residential amenity while not precluding future adaptive reuse*

Proposed: Subject site development is a new construction and therefore does not involve adapting existing buildings.

**Objective 4S-1**

*Mixed use developments are provided in appropriate locations and provide active street frontages that encourage pedestrian movement*

Proposed: N/A

**Objective 4S-2**

*Residential levels of the building are integrated within the development, and safety and amenity are maximised for residents*

Proposed: N/A.

**Objective 4T-1**

*Awnings are well located and complement and integrate with the building design*

Proposed: Complies.

**Objective 4T-2**

Signage responds to the context and desired streetscape character

Proposed: Signage will be limited to building identification, navigation and statutory signs. It will be designed to fit harmoniously in the architecture and contribute positively to the precinct.

**Objective 4U-1**

Development incorporates passive environmental design

Proposed: Natural light is provided to all habitable rooms, Solar and daylight access generally provided to habitable rooms. Natural ventilation generally provided to apartments.

**Objective 4U-2**

Development incorporates passive solar design to optimise heat storage in winter and reduce heat transfer in summer

**Proposed:** Light finishes will be used on exposed roof slabs, Balconies will provide shading from summer sun to the apartments. Insulated walls and roofs are provided. Seals on windows and doors are provided.

**Objective 4U-3**

Adequate natural ventilation minimises the need for mechanical ventilation

Proposed: The proposal achieves 69% of all apartments achieving natural cross ventilation.

**Objective 4V-1**

Potable water use is minimized

Proposed: The development will incorporate water efficient fittings, appliances and rainwater collection.

**Objective 4V-2**

Urban storm water is treated on site before being discharged to receiving waters

Proposed: Refer to civil engineering documents for further information.

**Objective 4V-3**

Flood management systems are integrated into site design

Proposed: No site specific flood zoning on subject site.

**Objective 4W-1**

Waste storage facilities are designed to minimise impacts on the streetscape, building entry and amenity of residents

Proposed: A Waste Management Plan has been prepared as part of the DA. Waste rooms for residents provided on basement level. Garbage collection is done from collection holding area at ground level to street collection proposed in line with the DCP.

**Objective 4W-2**

Domestic waste is minimised by providing safe and convenient source separation and recycling

Proposed: Provision of general waste and recycling bins provided within waste areas facilitate for safe and convenient disposal of waste.

**Objective 4X-1**

Building design detail provides protection from weathering

Proposed: The façade is detailed including overhangs to prevent staining and protect walls below; Planterboxes are designed to sit above paving levels for drainage and to minimise maintenance of waterproof membranes; Overhanging slabs will be detailed with drip lines to avoid staining.

**Objective 4X-2**

Systems and access enable ease of maintenance

Proposed: Suitable access for cleaning will be provided from the shared common circulation or appropriately controlled roof access; The majority of windows can be cleaned from inside or from balconies.

**Objective 4X-3**

Material selection reduces ongoing maintenance costs

Proposed: minimized painted surfaces and maximized natural and durable materials to be used.



# THANK YOU!



52 ALBION STREET  
SURRY HILLS  
NSW 2010

+61 2 9698 8140  
[WWW.PBDARCHITECTS.COM.AU](http://WWW.PBDARCHITECTS.COM.AU)

NOMINATED ARCHITECT  
PAUL BULJEVIC - NO.  
7768