



**BUILDING
INNOVATIONS
AUSTRALIA**

BCA & ACCESS 2022 INDICATIVE COMPLIANCE REPORT FOR DA LODGEMENT

**7 Blackbutts Road,
Frenchs Forest NSW 2086**



Prepared for: Monument Two Pty Ltd
Project No.: PRO-08895-T8Y3
Date: 01/08/2024
Status: Report Issue v1.0



Table of Contents

DOCUMENT HISTORY	3
1.0. INTRODUCTION	4
1.1. LOCATION AND DESCRIPTION	4
1.2. REPORT PURPOSE	4
1.3. BASIS OF REPORT	5
1.4. REFERENCED DOCUMENTS	5
1.5. LIMITATIONS AND EXCLUSIONS	5
1.6. LEGISLATIVE FRAMEWORK	6
1.7. TERMINOLOGY	9
2.0. BUILDING DESCRIPTION – PROPOSED DEVELOPMENT	10
2.1. BUILDING CODE OF AUSTRALIA DESCRIPTION	10
2.2. RISE IN STOREYS (RIS) (CLAUSE C2D3)	10
2.3. BUILDING CLASSIFICATIONS (PART A6)	10
2.4. EFFECTIVE HEIGHT (SCHEDULE 1)	11
2.5. TYPE OF CONSTRUCTION (TABLE C2D2)	11
2.6. FLOOR AREA AND VOLUME LIMITATIONS (TABLE C3D3)	11
2.7. FIRE PROTECTION AND STRUCTURAL CAPACITY (SECTION 14, FORMALLY CL. 143)	12
2.8. FIRE BRIGADE REFERRAL (SECTIONS 25-29, FORMALLY CL. 144)	12
3.0. BCA REQUIREMENTS	13
3.1. BCA 2022 CLAUSE BY CLAUSE ASSESSMENT	14
<i>Part B1 – Structural Provisions</i>	<i>14</i>
<i>Part C2 – Fire Resistance and Stability</i>	<i>15</i>
<i>Part C3 – Compartmentation and Separation</i>	<i>18</i>
<i>Part C4 – Protection of Openings</i>	<i>21</i>
<i>Specification 5–Fire-Resisting Construction</i>	<i>23</i>
<i>Part D2 – Provision for Escape</i>	<i>25</i>
<i>Part D3 – Construction of Exits</i>	<i>30</i>
<i>Part D4 – Access for People with Disabilities</i>	<i>40</i>
<i>Part E1 – Fire Fighting Equipment</i>	<i>53</i>
<i>Part E2 – Smoke Hazard Management</i>	<i>61</i>
<i>Part E3 – Lift Installations</i>	<i>65</i>
<i>Part E4 – Visibility in an Emergency, Exit Signs and Warning Systems</i>	<i>67</i>
<i>Part F1 – Surface water management, rising damp and external waterproofing</i>	<i>69</i>
<i>Part F2 – Wet areas and overflow protection</i>	<i>71</i>
<i>Part F3 – Roof and wall cladding</i>	<i>73</i>
<i>Part F4 – Sanitary and Other Facilities</i>	<i>74</i>
<i>Part F5 – Room heights</i>	<i>81</i>
<i>Part F6 – Light and Ventilation</i>	<i>82</i>
<i>Part F7 – Sound Transmission and Insulation</i>	<i>85</i>
<i>Part F8 – Condensation Management</i>	<i>85</i>
<i>Part G1 – Minor Structures and Components</i>	<i>86</i>
<i>Part G2 – Boilers, pressure vessels, heating appliances, fireplaces, chimneys and flues</i>	<i>86</i>
<i>Part G3 – Atrium construction</i>	<i>86</i>
<i>Part G4 – Construction in alpine areas</i>	<i>86</i>
<i>Part G5 – Construction in bushfire prone areas</i>	<i>86</i>



Part G6 – Occupiable outdoor areas..... 87
 Part G7 – Livable housing design..... 88
4.0. CONCLUSION 90
APPENDIX A – FIRE RESISTANCE LEVELS (TYPE A CONSTRUCTION) 91
 TABLE S5C11A: TYPE A CONSTRUCTION: FRL OF LOADBEARING PARTS OF EXTERNAL WALLS 91
 TABLE S5C11B: TYPE A CONSTRUCTION: FRL OF NON-LOADBEARING PARTS OF EXTERNAL WALLS 91
 TABLE S5C11C: TYPE A CONSTRUCTION: FRL OF EXTERNAL COLUMNS NOT INCORPORATED IN AN EXTERNAL WALL..... 91
 TABLE S5C11D: TYPE A CONSTRUCTION: FRL OF COMMON WALLS AND FIRE WALLS..... 91
 TABLE S5C11E: TYPE A CONSTRUCTION: FRL OF LOADBEARING INTERNAL WALLS 92
 TABLE S5C11F: TYPE A CONSTRUCTION: FRL OF NON-LOADBEARING INTERNAL WALLS..... 92
 TABLE S5C11G: TYPE A CONSTRUCTION: FRL OF OTHER BUILDING ELEMENTS NOT COVERED BY TABLES S5C11A TO S5C11F..... 92
APPENDIX B – SCHEDULE 2: REFERENCED DOCUMENTS..... 94
 TABLE 1 SCHEDULE OF REFERENCED DOCUMENTS 94
 NSW TABLE 1 SCHEDULE OF REFERENCED DOCUMENTS 101
APPENDIX C – REFERENCED DOCUMENTATION..... 102

Document History

Date	Issue	Status	Prepared by	Assessed by	Reviewed by
12.06.2024	Draft Report v0.1	Initial document created	Jennifer Lee	Mardiros Tatian	Mardiros Tatian
01.08.2024	Draft Report v0.2	Report updated to reflect latest plans	Jennifer Lee	Mardiros Tatian	Mardiros Tatian
01.08.2024	Report Issue v1.0	Report issued to client	Jennifer Lee	Mardiros Tatian	Mardiros Tatian

Liability limited by a scheme approved under Professional Standards Legislation.

1.0. INTRODUCTION

1.1. Location and Description

This report is prepared in preparation of a Development Application (DA) lodgement and is for assessment purposes, it comprises a National Building Code of Australia 2022 (NBCA) assessment of the proposed early childhood centre as required under Section 19 of the Environmental Planning and Assessment Regulations.

The development incorporates the demolition of existing structures and construction of a new three (3) storey Class 9b Childcare Centre and associated parking spaces provided within the Basement Floor Level.



Figure 1 *Site location and topography*

1.2. Report Purpose

The purpose of this report is to provide an indicative compliance assessment of the DA design documentation for the proposal, against the current requirements of the BCA.

Demonstrating compliance with the BCA is not a prescribed head of consideration under Section 4.15 (formally Section 79C) of the Environmental Planning & Assessment Act 1979. It is noted however that Council has an obligation to consider whether the DA proposal, as lodged, is indicatively capable of complying with the BCA - without significant modification to those plans for which approval is sought.

This report will demonstrate that there will be no additional requirements, resulting from prescribed application of the BCA, for any significant design changes that would necessitate the submission of an application under Section 4.55 (formally Section 96) of the Environmental Planning and Assessment Act 1979.

As such, and to pre-empt the Certifying Authority's role under Section 19 of the Environmental Planning & Assessment (Development Certification and Fire Safety) Regulation 2021, we have undertaken a preliminary assessment of the development against the provisions of the BCA applicable to the lodged Development Application.

1.3. Basis of Report

This report is based upon and limited to:

- An assessment of design documentation referenced in Appendix A of this report.
- The Deemed-to-Satisfy provisions of the National Building Code of Australia 2022 including the NSW variations where applicable.

1.4. Referenced Documents

The following documentation was relied upon when preparing this report:

- Assessment of design documentation referenced in Appendix B of this report.
- The performance and deemed-to-satisfy provisions of the National Building Code of Australia 2022 incorporating the NSW Appendices where applicable.
- Guide to the National Building Code of Australia.
- Disability (Access to Premises — Buildings) Standards 2010.
- Environmental Planning & Assessment Act 1979.
- Environmental Planning & Assessment (Development Certification and Fire Safety) Regulation 2021.
- Environmental Planning & Assessment Regulation 2021.

1.5. Limitations and Exclusions

The limitations and exclusions of this report are as follows:

- The plans are assessed indicatively to the extent necessary to proceed to construction certificate stage whereby assessment will be undertaken pursuant to Part 4A of the Environmental Planning and Assessment Act 1979. This means that the design has been assessed to be able to comply with the BCA (i.e. the submitted plans are consistent with the BCA but certain design details may not be specified at this stage due to the plans and specifications being at pre DA stage).
- This Report does not address issues in relation to the following:
 - a) The structural adequacy of the building including the Fire Resistance Levels (FRL's) of any building elements (unless specifically referred to).
 - b) The design, maintenance or operation electrical, mechanical, hydraulic or fire protection services.
 - c) Environmental Planning and Assessment Act and Regulations (unless specifically referred to).
 - d) Local Government Act and Regulations.
 - e) Occupational Health and Safety Act and Regulations.
 - f) WorkCover Authority requirements.
 - g) Requirements of other Regulatory Authorities including, but not limited to, Telstra, Sydney Water, Electricity Supply Authority, RTA, Council and the like.
 - h) Disability Discrimination Act (DDA) other than minimum requirements under the Disability (Access to Premises — Buildings) Standards 2010. DDA is a Case by Case Assessment, this building will comply with the set items under the Premises Standards.
 - i) Construction Safety Act.
 - j) Conditions of Development Consent issued by the relevant Local Council.

- This assessment does not incorporate the detailed requirements of the Australian Standards.
- Building Innovations Australia Pty Ltd cannot guarantee acceptance of this report by the Local Council, NSW Fire Brigades or other approval authorities.
- Without written permission from Building Innovations Australia Pty Ltd, no part of this document may be reproduced in any form or by any means. This report is based solely on client instructions, and therefore should not be used by any third party without prior knowledge of such instructions.

1.6. Legislative Framework

Section 4.15 (formally Section 79C) of the Environmental Planning and Assessment Act provides the matters of consideration that the consent authority must take into account in the determination of a development application.

Once development consent is granted, and pursuant to Section 19 of the Environmental Planning & Assessment (Development Certification and Fire Safety) Regulation 2021, a certifying authority must not issue a construction certificate for building work unless:

- the relevant building work plans and specifications include the matters required by a relevant BASIX certificate, if any, and*
- the design and construction of the building, as described in the relevant building work plans and specifications and in other information given to the certifier under section 12, is consistent with the development consent, and*
- the building will comply with the relevant requirements of the Building Code of Australia as in force at the time the application for the construction certificate was made.*

Compliance with the National Building Code of Australia

The BCA is a performance based document whereby compliance can be achieved by satisfying the deemed to satisfy requirements or by formulating an alternative solution to address the relevant performance requirements.

As indicated above, the requirements of the Environmental Planning and Assessment Regulations 2000 requires all new building works to comply with the relevant requirements of the BCA (as in force at the time the application for the construction certificate was made).

This means that the plans and documentation submitted with the *construction certificate* (CC) application must demonstrate full compliance with the relevant provisions of the Building Code of Australia.

Section 14 Fire protection and structural capacity

If your development incorporates a Change of Use, Category 1 fire safety measures must be considered and implemented into the design as applicable:

- E1P3: A fire hydrant system*
- E1P4: An automatic fire suppression system*
- E1P6: Suitable facilities must be provided to the degree necessary in a building to co-ordinate fire brigade intervention*
- E2P1: Sleeping Accommodation, occupants must be provided with automatic warning*
- E2P2: Conditions in any evacuation route must be maintained for the period of time occupants take to evacuate*
- E3P2: One or more passenger lifts fitted as emergency lifts to serve each floor served by the lifts in a building must be installed to facilitate the activities of the fire brigade and other emergency services personnel*

Details of the above will need to be identified on the Building Fire Safety Schedule/Statement as present, if not present; these measures will need to be installed in to the building if applicable.

Referral of certain plans and specifications to New South Wales Fire Brigades

Under the Environmental Planning & Assessment (Development Certification and Fire Safety) Regulation 2021, Section 18 and Sections 25-29 have specific requirements for any Fire Engineering which identifies Category 2 fire safety provisions which form part of a building being more than 6,000m² and/or within a Fire Compartment more than 2,000m².

Category 2 means the following provisions of the Building Code of Australia, namely, C1P9, E1P3, E1P4, E1P6, E2P2 and E3P2 in Volume One of that Code

If this building has a floor area of more than 6,000m² or a performance solution is proposed within a fire compartment more than 2,000m², any Performance Solution which identifies one or more of the above performance provisions, Fire Brigade approval is required in the form of a Section 25-29 (formally Cl. 144) Approval along with a required Engineering Statement under Section 18 (formally Cl. 144A) and following the completion of the building a Section 50 (formally Cl. 152) Report from the Fire Commissioner is required, a final fire safety report for a building means a written report specifying whether or not the Fire Commissioner is satisfied that:

- (a) the building work complies with a performance solution for a Category 2 fire safety provision that was the subject of the construction certificate, and
- (b) the fire hydrants in the fire hydrant system will be accessible for use by Fire and Rescue NSW, and
- (c) the couplings in the fire hydrant system will be compatible with the fire appliances and equipment used by Fire and Rescue NSW.



Fulfilment of BASIX Commitments (Residential only)

Section 43 of the Environmental Planning & Assessment (Development Certification and Fire Safety) Regulation 2021 requires a certifying authority to monitor fulfilment of any commitments listed on the BASIX certificate, where the BASIX requires the certifying authority to monitor those commitments.

A certifying authority must not issue an occupation certificate (whether interim or final) for any building resulting from, or any building that becomes a BASIX affected building because of, BASIX affected development or BASIX optional development to which this clause applies, or for any part of such a building, unless each of the commitments whose fulfilment it is required to monitor in relation to the building or part has been fulfilled.

For the purpose of satisfying itself as to the fulfilment of any such commitment, a certifying authority may rely on the advice of any properly qualified person (i.e. Energy Efficiency Consultant).

Special Requirements for Residential Flat Developments

Section 15 (formally Cl. 143A) of the Environmental Planning & Assessment (Development Certification and Fire Safety) Regulation 2021 requires a qualified designer to provide a statement that verifies that the plans and specifications that form part of construction certificate application achieve or improve the design quality of the development having regard to the design quality principles set out in Part 2 of the State Environmental Planning Policy No. 65 – Design Quality of Residential Flat Development prior to the issue of a Construction Certificate.

Section 43 (formally Cl. 154A) of the Environmental Planning & Assessment (Development Certification and Fire Safety) Regulation 2021 requires a qualified designer to provide a statement that verifies that the residential flat development achieves the design quality of the development as shown in the plans and specifications having regard to the design quality principles set out in Part 2 of the State Environmental Planning Policy No. 65 – Design Quality of Residential Flat Development prior to the issue of an Occupation Certificate.

Disability (Access to Premises — Buildings) Standards 2010

Disability (Access to Premises — Buildings) Standards 2010 has been introduced and is applicable to this building. It is noted that unless Part D4, Clauses E3D7, E3D8, F4D5, F4D6 & F4D7 are included in the below assessment, an access consultant may need to be engaged to provide specific comments as to compliance with this standard. Note that except for slight variations, particularly for Class 1b buildings, available verification methods and adult change facilities, as this is a new building to BCA 2022, compliance with the Disability (Access to Premises — Buildings) Standards 2010 would inherently comply.



1.7. Terminology

- *Building Code of Australia* - Document published on behalf of the Australian Building Codes Board. The BCA is a uniform set of technical provisions for the design and construction of buildings and other structures throughout Australia and is adopted in NSW under the provisions of the Environmental Planning & Assessment Act & Regulation.
- *Fire Resistance Level (FRL)* - means the grading periods in minutes tested in accordance with AS 1530.4-2005 for the following criteria -
 - (a) structural adequacy; and
 - (b) integrity; and
 - (c) insulation,and expressed in that order.
- *Fire Source Feature (FSF)* - the far boundary of a road adjoining the allotment; or a side or rear boundary of the allotment; or an external wall of another building on the allotment which is not a Class 10 building.
- *Open space* - means a space on the allotment, or a roof or other part of the building suitably protected from fire, open to the sky and connected directly with a public road.
- *Performance Requirements of the BCA* - A Building Solution will comply with the BCA if it satisfies the Performance Requirements. A Performance requirement states the level of performance that a Building Solution must achieve.

Compliance with the Performance Requirements can only be achieved by-

 - (a) complying with the Deemed-to-Satisfy Provisions; or
 - (b) formulating a Performance Solution which-
 - (i) complies with the Performance Requirements; or
 - (ii) is shown to be at least equivalent to the Deemed-to-Satisfy Provisions; or
 - (c) a combination of (a) and (b).
- *Sole occupancy unit* - means a room or other part of a building for occupation by one or joint owner, lessee, tenant, or other occupier to the exclusion of any other owner, lessee, tenant, or other occupier.

2.0. BUILDING DESCRIPTION – PROPOSED DEVELOPMENT

2.1. Building Code of Australia Description

For the purposes of the Building Code of Australia 2022 (BCA) the proposed development may be described as follows.

2.2. Rise in Storeys (RIS) (Clause C2D3)

The overall building has a rise in storeys of three (3) as illustrated below;

The number of storeys contained is three (3)

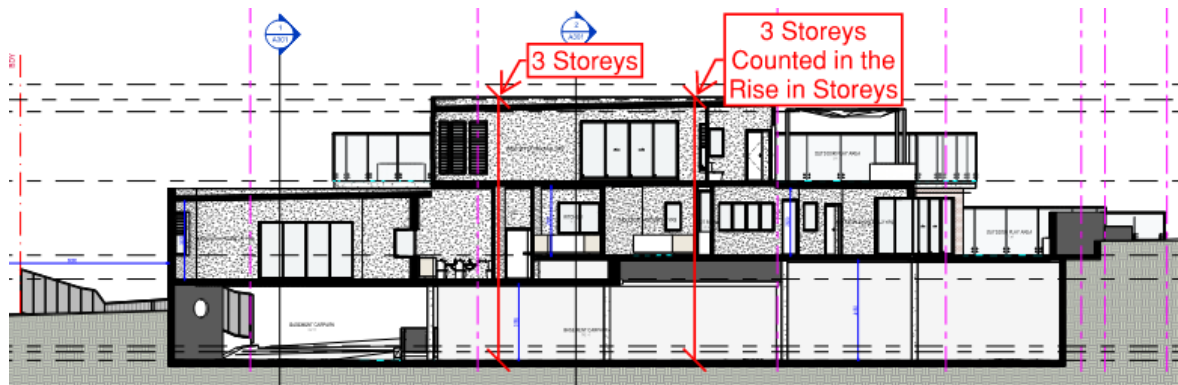

2.3. Building Classifications (Part A6)

The proposed building has been classified as follows.

BUILDING LEVELS	PLAN LEVELS	CLASSIFICATION	USE	RIS
Basement Floor	Basement Level	Class 7a	Carpark	1
Ground Floor	Ground Level	Class 9b	Childcare Centre	2
First Floor	Level 1	Class 9b	Childcare Centre	3
Roof	-	-	-	-

2.4. Effective Height (Schedule 1)

The building has an effective height (EH) of approximately **7.50m** when measured from the floor of the topmost storey which is less than 12m.

*Lowest Point taken @ RL 153.60 (Approx.)

*Highest Point taken @ RL 161.10

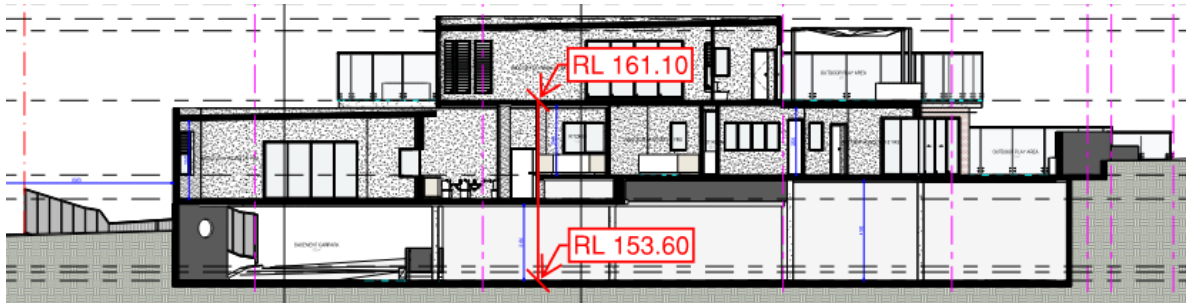

2.5. Type of Construction (Table C2D2)

The building is required to be of **Type 'A'** Construction.

2.6. Floor Area and Volume Limitations (Table C3D3)

The building is subject to maximum floor area and volume limits under Type 'A' Construction of:

CLASS OF BUILDING PART	FLOOR AREA & VOLUME		OUTCOME
	MAX PERMITTED (TABLE C3D3)	MAX. PROPOSED	
▪ Class 7a	5,000 m ²	< 5,000 m ²	Complies
	30,000 m ³	< 30,000 m ³	
▪ Class 9b	8,000 m ²	< 8,000 m ²	Complies
	48,000 m ³	< 48,000 m ³	

**Class 7a is exempt from Table C3D3 Floor Area restrictions if Carpark is proposed to be Sprinkler Protected pursuant to Clause E1D4.*



2.7. Fire protection and structural capacity (Section 14, formally Cl. 143)

If your development incorporates a Change of Use, Category 1 fire safety measures must be considered and implemented in to the design as applicable.

- E1P3: A fire hydrant system (required)*
- E1P4: An automatic fire suppression system*
- E1P6: Suitable facilities must be provided to the degree necessary in a building to co-ordinate fire brigade intervention*
- E2P1: Sleeping Accommodation, occupants must be provided with automatic warning*
- E2P2: Conditions in any evacuation route must be maintained for the period of time occupants take to evacuate*
- E3P2: One or more passenger lifts fitted as emergency lifts to serve each floor served by the lifts in a building must be installed to facilitate the activities of the fire brigade and other emergency services personnel*

2.8. Fire Brigade referral (Sections 25-29, formally Cl. 144)

If this building requires Fire Engineering referral would need to be forwarded to the NSW Fire Brigades under a Section 25-29 fire brigade referral.

3.0. BCA REQUIREMENTS

Noting that the level of documentation at this stage is for a Development Application (DA) assessment purposes, an indicative compliance assessment of the referenced documents identified in Appendix B of this report has been undertaken against the Deemed-to-Satisfy Provisions of the National Building Code of Australia 2022 (BCA).

Outlined below is a summary of the Deemed-to-Satisfy Provisions of the BCA. All Deemed-to-Satisfy clauses that are applicable to the subject building have been referred to below, including a comment adjacent to each clause of the proposal's ability to satisfy each respective clause.

The abbreviations outlined below have been used in the following tables:

N / A	The Deemed-to-Satisfy clause does not apply to the subject Building.
Complies	The relevant provisions of the Deemed-to-Satisfy clause have been demonstrated by the proposed design and existing building features, notwithstanding it is at DA documentation stage.
CRA	'Compliance Readily Achievable'. It is considered that the level of detail included in the DA documentation will not determine strict compliance with the individual BCA clause requirements. However, subject to noting the requirements of each clause, it is considered BCA compliance can be readily demonstrated without significant implication to the approved design. This will occur through progression of documentation to the Construction Certificate stage of the development.
FI	Further information is necessary to determine the compliance potential of the building design.
PS	Performance Solution with respect to this Deemed-to-Satisfy Provision is possible to satisfy the relevant BCA Performance Requirements.
DNC	Does Not Comply.
DTS	Deemed-To-Satisfy provisions as defined by the National Building Code of Australia 2022.

3.1. BCA 2022 Clause by Clause Assessment

SECTION B – STRUCTURE

Part B1 – Structural Provisions			
Clause	Description	Status	Comments
B1D1	Deemed-to-Satisfy Provisions	-	-
B1D2	Resistance to actions	CRA	The resistance of a building or structure must be greater than the most critical action effect resulting from different combinations of actions. Structural details and a design certificate will be obtained from a qualified structural engineer prior to the issue of a Construction Certificate.
B1D3	Determination of individual actions	CRA	The magnitude of individual actions must be determined in accordance with Clause B1D3 of the BCA. Structural details and a design certificate will be obtained from a qualified structural engineer prior to the issue of a Construction Certificate.
B1D4	Determination of structural resistance of materials and forms of construction	CRA	The structural resistance of materials and forms of construction must be determined in accordance with the relevant Australian Standards in accordance with Clause B1D4 of the BCA. Structural details and a design certificate will be required by a qualified structural engineer prior to the issue of a Construction Certificate.
B1D5	Structural Software	Noted	
B1D6	Construction of buildings in flood hazard areas	Noted	

SECTION C – FIRE RESISTANCE

Part C2 – Fire Resistance and Stability							
Clause	Description	Status	Comments				
C2D1	Deemed-to-Satisfy Provisions	-	-				
C2D2	Type of construction required	CRA	The building is to be erected in Type 'A' fire resisting construction in accordance with Specification 5 of the BCA. Refer to 'Appendix' A for the relevant fire resisting requirements. Plans to reflect required FRLs prior to the issue of a Construction Certificate.				
C2D3	Calculation of rise in storeys	Noted	The building has an overall rise in storeys of three (3) The building contains three (3) storeys.				
C2D4	Buildings of multiple classification	Noted	The building is required to be constructed of Type 'A' fire resisting construction as the classification of the top storey is a Class 9b.				
C2D5	Mixed types of Construction	Noted	If a fire wall divides the building in accordance with Clause C3D8, the building portions are able to be constructed in differing levels of fire-resistance determined in accordance with Clause C2D2 and C2D4.				
C2D6	Two storey Class 2, 3 or 9c buildings	N / A					
C2D7	Class 4 parts of buildings	N / A					
C2D8	Open spectator stands and indoor sports stadiums	N / A					
C2D9	Lightweight construction	CRA	Lightweight construction used in a wall system must comply with Specification 6. Lightweight construction used as a fire-resisting covering of a steel column or the like, and where the covering is not in continuous contact with the column must have the voids filled to a height of not less than 1.2m above the floor and where the column is liable to be damaged must be protected by steel or other suitable material. If lightweight construction is used in the proposed development, then details demonstrating required FRL and compliance with this clause must be provided prior to the issue of a Construction Certificate.				
C2D10	Non-combustible building elements	CRA or PS	In a building required to be of Type A construction, the following building elements and their components must be non-combustible, concrete, masonry or fire protected timber: <table border="1" style="width: 100%; margin-top: 10px;"> <thead> <tr> <th style="width: 50%;">Building Element</th> <th style="width: 50%;">Type A Construction</th> </tr> </thead> <tbody> <tr> <td>External wall</td> <td>Non-combustible</td> </tr> </tbody> </table>	Building Element	Type A Construction	External wall	Non-combustible
Building Element	Type A Construction						
External wall	Non-combustible						

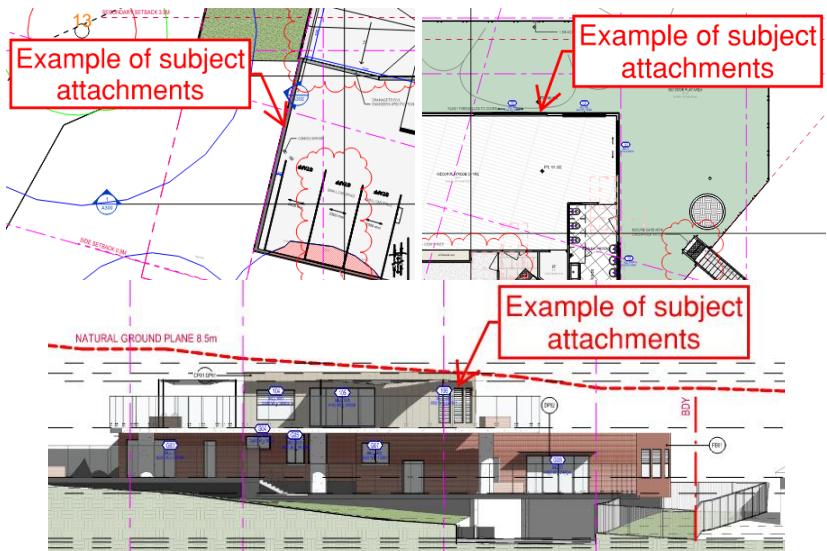
Part C2 – Fire Resistance and Stability															
Clause	Description	Status	Comments												
			<table border="1"> <tr> <td>Common wall</td> <td>Non-combustible</td> </tr> <tr> <td>Floor and floor framing of lift pit</td> <td>Non-combustible</td> </tr> <tr> <td>All loadbearing internal walls (including shaft walls)</td> <td>Concrete, masonry or fire-protected timber</td> </tr> <tr> <td>Loadbearing fire walls</td> <td>Concrete, masonry or fire-protected timber</td> </tr> <tr> <td>Non-loadbearing internal walls required to be fire-resistant</td> <td>Non-combustible</td> </tr> <tr> <td>Non-loadbearing lift, ventilating, pipe, garbage and like shafts which do not discharge hot products of combustion</td> <td>Non-combustible</td> </tr> </table> <p>Attachments</p> <p>Proposed attachments are to comply with the requirements of C2D10 and C2D14 of the BCA as applicable:</p>  <p>Should materials that do not form part of a tested system be utilised such as Dintel, AFS Rediwall or the like, design certification verifying compliance to be provided or alternatively a fire engineering performance solution can be undertaken prior to the issue of the Construction Certificate.</p>	Common wall	Non-combustible	Floor and floor framing of lift pit	Non-combustible	All loadbearing internal walls (including shaft walls)	Concrete, masonry or fire-protected timber	Loadbearing fire walls	Concrete, masonry or fire-protected timber	Non-loadbearing internal walls required to be fire-resistant	Non-combustible	Non-loadbearing lift, ventilating, pipe, garbage and like shafts which do not discharge hot products of combustion	Non-combustible
Common wall	Non-combustible														
Floor and floor framing of lift pit	Non-combustible														
All loadbearing internal walls (including shaft walls)	Concrete, masonry or fire-protected timber														
Loadbearing fire walls	Concrete, masonry or fire-protected timber														
Non-loadbearing internal walls required to be fire-resistant	Non-combustible														
Non-loadbearing lift, ventilating, pipe, garbage and like shafts which do not discharge hot products of combustion	Non-combustible														
C2D11	Fire hazard properties	CRA	<p>The fire hazard properties of all floor materials, floor coverings, wall and ceiling lining materials must comply with Specification 7. The fire hazard properties of all other materials must comply with Specification 7.</p> <p>Design certification will be required verifying compliance prior to the issue of a Construction Certificate.</p>												
C2D12	Performance of external walls in fire	N / A	Concrete external walls that could collapse as complete panels (e.g. tilt-up and pre-cast concrete), in a building having a rise in storeys of not more than 2, must comply with Specification 8.												



Part C2 – Fire Resistance and Stability			
Clause	Description	Status	Comments
C2D13	Fire-protected timber: Concession	N / A	
C2D14	Ancillary elements	CRA	<p>An ancillary element must not be fixed, installed, attached to or supported by the internal parts or external face of an external wall that is required to be non-combustible unless it is determined to meet certain fire properties and limitations on the extent of coverage.</p> <p>Design certification will be required verifying compliance prior to the issue of a Construction Certificate.</p>
C2D15	Fixing of bonded laminated cladding panels	CRA	<p>In a building required to be of Type A or B construction, externally located bonded laminated cladding panels must have all layers of cladding mechanically supported or restrained to the supporting frame.</p> <p>Design certification will be required verifying compliance prior to the issue of a Construction Certificate.</p>

Part C3 – Compartmentation and Separation			
Clause	Description	Status	Comments
C3D1	Deemed-to-Satisfy Provisions	-	-
C3D2	Application of Part	Noted	Clauses C3D3, C3D4 and C3D5 do not apply to a sprinkler protected carpark, open deck carpark or open spectator stand.
C3D3	General floor area and volume limitations	Complies	All parts of the building comply and are within compartment limitations.
C3D4	Large isolated buildings	N / A	
C3D5	Requirements for open spaces and vehicular access	N / A	
C3D6	Class 9 buildings	PS	<p>(2) In a building containing Class 9b early childcare centre:</p> <ul style="list-style-type: none"> • Unless the Class 9b early childhood centre is the only use in the building, it must be separated from the remainder of the building by walls and/or floors with an FRL not less than that required for a fire wall; and • Each storey within the class 9b early childhood centre must contain not less than 2 fire compartments <p>C3D6(2) does not apply to a Class 9b early childhood centre-</p> <p>(a) wholly within a storey that provides direct egress to a road or open space; or</p> <p>(b) with a rise in storeys of not more than 2, where the Class 9b early childhood centre is the only use in the building.</p> <p>This building is not exempt from the requirements of this clause as the basement carpark means the Class 9b early childhood centre is not the only use in the building.</p> <p>The Ground and First Floor Levels of the building are not provided with two (2) separate fire compartments</p> <p>Compliance can be achieved via undertaking a fire engineering performance solution prior to the issue of the Construction Certificate.</p>
C3D7	Vertical separation of Openings in external walls	CRA	<p>In a building of Type 'A' construction that is not sprinkler protected (or provided with a FPAA101D or FPAA101H system), a spandrel must be provided. The spandrel must be not less than 900mm in height, extended not less than 600mm above the upper surface of the intervening floor and be of non-combustible material having an FRL of not less than 60/60/60.</p> <p>Alternatively, a slab or other horizontal construction that projects outwards not less than 1100mm and extends 450mm beyond the opening and be of non-combustible material having an FRL of not less than 60/60/60.</p>

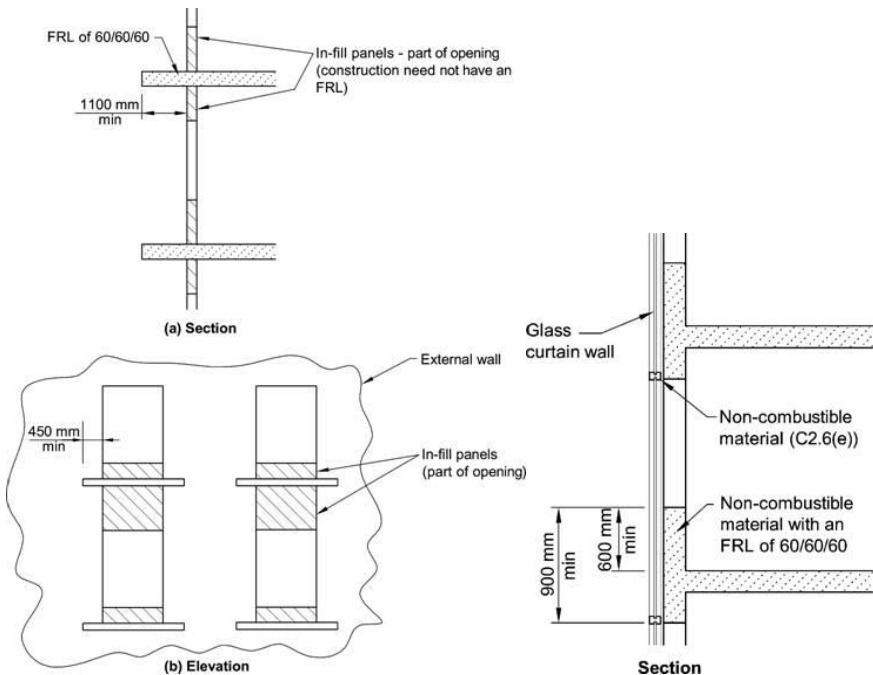
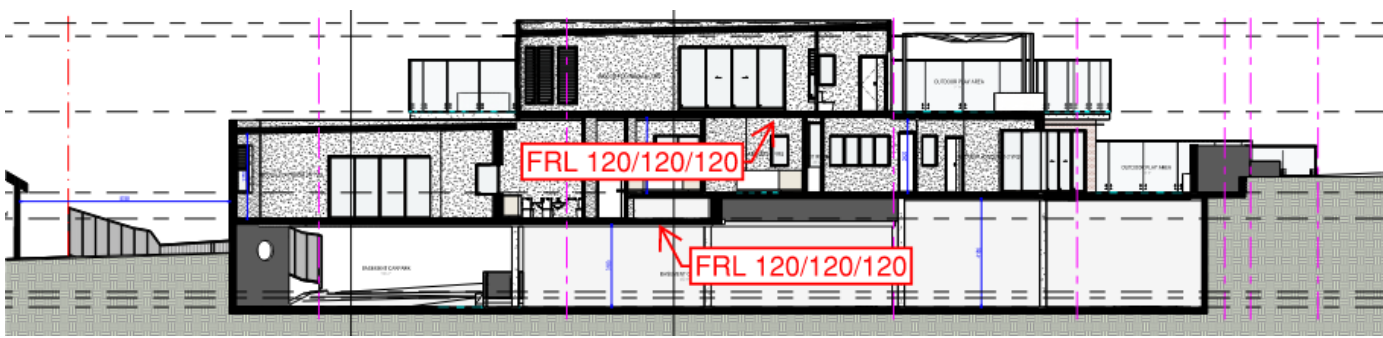

Part C3 – Compartmentation and Separation			
Clause	Description	Status	Comments
			Design verification to be provided prior to the issue of the Construction Certificate.
			
C3D8	Separation by fire walls	Noted	
C3D9	Separation of classifications in the same storey	Noted	Refer to Clause C3D8 if applicable.
C3D10	Separation of classifications in different storeys	CRA	<p>The floor slab separating the different storeys require an FRL of:</p> <ul style="list-style-type: none"> • Basement/ground floor FRL 120/120/120; and • Ground/first floor FRL 120/120/120. <p>Refer to 'Appendix' A for the relevant fire resisting requirements. Plans to reflect required FRLs prior to the issue of a Construction Certificate.</p>
			

Part C3 – Compartmentation and Separation			
Clause	Description	Status	Comments
C3D11	Separation of lift shafts	CRA	<p>Any lift connecting more than 2 storeys building must be separated from the remainder of the building with material that achieves a FRL appropriate to that storey as required by Table S5C11d of Specification 5 and if required to be an emergency lift of not less than 120/120/120.</p> <p>Any opening in the fire-isolated lift shaft must be protected in accordance with Clause C4D11 of the BCA.</p> <p>Design verification to be provided prior to the issue of the Construction Certificate.</p>
C3D12	Stairways and lifts in one shaft	CRA	<p>A stairway and lift must not be in the same shaft if either the stairway or the lift is required to be in a fire-resisting shaft.</p> <p>Both the stairways & lifts appear to be in separate shafts</p>
C3D13	Separation of equipment	CRA	<p>Equipment that comprises lift motors, lift control panels, central smoke control plant, boilers or batteries must be separated from the remainder of the building by construction with an FRL as required under Specification 5 but not less than 120/120/120 and any doorways in that construction protected with a self-closing –/120/30 fire door.</p> <p>Design certification will be required verifying compliance prior to the issue of a Construction Certificate.</p>
<p>Note: Clause 6.11.2 of AS 2419.1-2021 requires that an internal pumproom located within the building shall have the following:</p> <ul style="list-style-type: none"> • A door opening to a road or open space, or a door opening to fire-isolated passage or stair which leads to a road or open space; and • Except where the building is sprinkler protected in accordance with AS 2118.1, AS 2118.4, AS 2118.6 or FPAA101H, enclosing walls with an FRL not less than that prescribed by the BCA for a firewall for the particular building classifications served by the fire hydrant system. 			
C3D14	Electricity supply system	CRA	<p>The following electricity supply equipment:</p> <ul style="list-style-type: none"> • electrical substation (TBA) • main switchboard which sustains emergency equipment operating in emergency mode (TBA) • electricity conductors which supply substation or main switchboard (TBA) <p>Must be separated from the remainder of the building by construction with an FRL of not less than 120/120/120 and any doorways in that construction protected with a self-closing –/120/30 fire door.</p> <p>Final details verifying compliance can be provided on plans prior to the issue of a Construction Certificate.</p>
C3D15	Public corridors in Class 2 and 3 buildings	N / A	

Part C4 – Protection of Openings			
Clause	Description	Status	Comments
C4D1	Deemed-to-satisfy Provisions	-	-
C4D2	Application of Part	Noted	Concessions and definition of certain openings.
C4D3	Protection of openings in external walls	Noted	<p>Openings within 3m of an allotment boundary shall be protected by sprinklers, fire doors, fire windows etc, in accordance with Clause C4D5 of the BCA.</p> <p>No openings throughout the development appear to be located within 3m of the side allotment boundary.</p> <p>Design verification to be provided prior to the issue of the Construction Certificate.</p>
C4D4	Separation of external walls and associated openings in different fire compartments	CRA	<p>The distance between parts of external walls and any openings within them in different fire compartments separated by a fire wall must not be less than that set out in Table C4D4, unless—</p> <p>(a) those parts of each wall have an FRL not less than 60/60/60; and</p> <p>(b) any openings protected in accordance with C4D4.</p> <p>Design certification will be required verifying compliance prior to the issue of a Construction Certificate.</p>
C4D5	Acceptable methods of protection	CRA	<p>Window openings that are required to be protected are to be protected by wall wetting sprinklers with windows that are automatic closing or permanently fixed in the closed position, --/60/-- fire windows or --/60/60 automatic fire shutters.</p> <p>Other openings that required to be protected are to be protected by internal or external wall-wetting sprinklers or have construction with an FRL not less than --/60/--.</p> <p>Plans to reflect required FRLs and location of openings protected in accordance with Clause C4D5 of the BCA prior to the issue of a Construction Certificate.</p>
C4D6	Doorways in fire walls	CRA	<p>If the ground floor childcare is to be separated using fire walls, all doors in the fire walls are to be protected in accordance with Clause C4D6 of the BCA.</p> <p>Design certification will be required verifying compliance prior to the issue of a Construction Certificate.</p>
C4D7	Sliding fire doors	N / A	
C4D8	Protection of doorways in horizontal exits	Noted	
C4D9	Openings in fire-isolated exits	Noted	No fire isolated exits proposed in the current design.

Part C4 – Protection of Openings			
Clause	Description	Status	Comments
C4D10	Service penetrations in fire isolated exits	Noted	No fire isolated exits proposed in the current design.
C4D11	Openings in fire-isolated lift shafts	CRA	<p>Openings in lift shafts are to be protected by –/60/– fire doors complying with AS1735.11.</p> <p>Lift indicator panels are to be backed by construction having an FRL of not less than –/60/60 if it exceeds 35,000mm² (175mm X 200 mm).</p> <p>Details verifying compliance must be provided on plans prior to the issue of a Construction Certificate.</p>
C4D12	Bounding construction: Class 2 and 3 buildings and Class 4 parts	N / A	
C4D13	Openings in floors and ceilings for services	CRA	<p>Services passing through floors are to be placed within fire resisting shafts or in accordance with Clause C4D15.</p> <p>Details verifying compliance must be provided on plans prior to the issue of a Construction Certificate.</p>
C4D14	Openings in shafts	CRA	<p>In a building of Type A construction, an opening in a wall providing access to a ventilating, pipe, garbage, or other service shaft must be protected by:</p> <ul style="list-style-type: none"> • If it is a sanitary compartment - a door or panel which together with its frame, is non-combustible or has an FRL of not less than –/30/30, or • A self-closing –/60/30 fire door or hopper, or • An access panel with an FRL of not less than –/60/30, or • If the shaft is a garbage shaft - a door or hopper of non-combustible construction. <p>Details verifying compliance must be provided on plans prior to the issue of a Construction Certificate.</p>
C4D15	Openings for service installation	CRA	<p>Where services (e.g. hydraulic, mechanical, plumbing, electrical) penetrate a building element that is required to achieve an FRL with respect to integrity or insulation or a resistance to the incipient spread of fire then that installation must be protected / sealed (e.g. fire collars, fire dampers etc) by material that is identical to tested prototypes and in accordance with AS4072.1 and AS1530.4, and having achieved the required FRL or resistance to the incipient spread of fire or other specified method.</p> <p>Details verifying compliance must be provided on plans prior to the issue of a Construction Certificate.</p>
C4D16	Construction Joints	CRA	Construction joints are to be installed in accordance with a tested prototype in accordance with AS1530.4.

Part C4 – Protection of Openings			
Clause	Description	Status	Comments
			Details verifying compliance must be provided on plans prior to the issue of a Construction Certificate.
C4D17	Columns protected with lightweight construction	CRA	Columns must be protected in accordance with the identical tested prototype. Details verifying compliance must be provided on plans prior to the issue of a Construction Certificate.

Specification 5–Fire-Resisting Construction			
Clause	Description	Status	Comments
Spec 5	Requirements for Type A construction	CRA or PS	<p>Clause C2D2 requires the building to be constructed as Type A construction in accordance with Part S5C2-S5C20, Part S5C11-S5C20 and Tables S5C11a–g of Specification 5 of the BCA.</p> <p>External Walls</p> <p>All load-bearing and non-load-bearing walls are required to achieve an FRL tested from both sides as stipulated by Tables S5C11a–g of Specification 5.</p>  <p>Attachments</p> <p>All attachments are to comply with the requirements in Specification 5 & Clause C2D11 and meet the intent of Clause S5D5 of Spec 5.</p> 

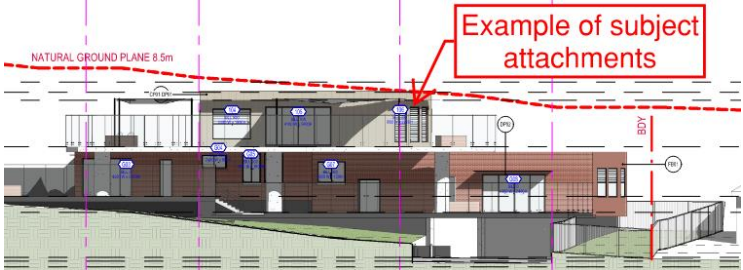
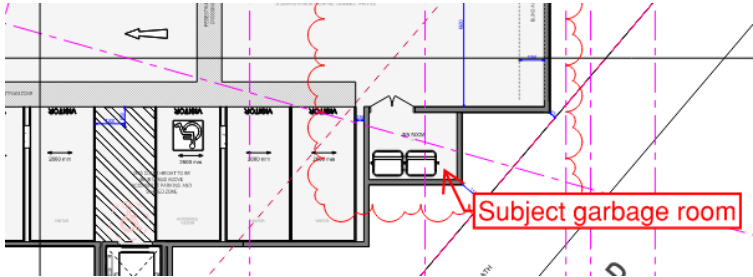
Specification 5–Fire-Resisting Construction			
Clause	Description	Status	Comments
			 <p>Should material that does not form part of a tested system be utilised such as Dintel, AFS Rediwall or the like, compliance can be achieved via a fire engineering performance solution undertaken prior to the issue of the Construction Certificate.</p> <p>Fire Rated Shelf Angles</p> <p>Any shelf angles provided to the building are to achieve the same FRL as the slab in which it is attached to.</p> <p>Garbage Room(s)</p> <p>The basement floor garbage room(s) are to be enclosed with FRL 120/120/120 construction and fitted with FRL –/120/30 fire doors in accordance with Specification 5 of the BCA.</p>  <p>Details verifying compliance must be provided on plans or alternatively a fire engineering performance solution can be undertaken prior to the issue of the Construction Certificate.</p>

SECTION D – ACCESS AND EGRESS

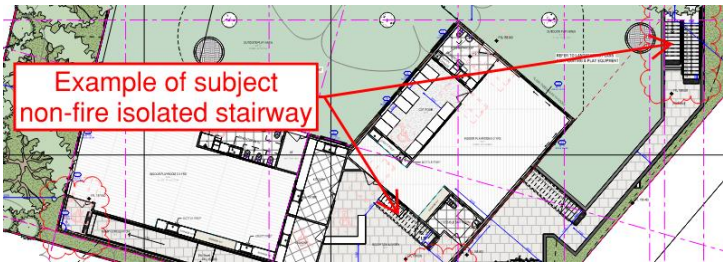
Part D2 – Provision for Escape			
Clause	Description	Status	Comments
D2D1	Deemed-to-Satisfy Provisions	-	-
D2D2	Application of Part	Noted	Does not apply to the internal parts of a sole occupancy unit in a Class 2, 3 or 4 building.
D2D3	Number of exits required	Complies	Building has effective height less than 25m. Each storey in a Class 9b building is required to have not less than 2 exits. Each storey is provided with not less than 2 exits
D2D4	When fire-isolated stairways and ramps are required	PS	<p>In a Class 5, 6, 7, 8 or 9 building, every stairway or ramp serving as a required exit must be fire-isolated unless it connects, passes through or passes by not more than 2 consecutive storeys and one extra storey of any classification may be included if—</p> <ul style="list-style-type: none"> • the building has a sprinkler system (other than a FPAA101D system) complying with Specification 17 installed throughout; or • the required exit does not provide access to or egress for, and is separated from, the extra storey by construction having— <ul style="list-style-type: none"> ○ an FRL of –/60/60, if non-loadbearing; and ○ an FRL of 90/90/90 for Type A construction or 60/60/60 for Type B construction, if loadbearing; and ○ no opening that could permit the passage of fire or smoke. <p>D2D4(2) does not apply to—</p> <ul style="list-style-type: none"> • a Class 9b early childhood centre wholly within a storey that provides direct egress to a road or open space; or • a Class 9b early childhood centre with a rise in storeys of not more than 2, where the Class 9b early childhood centres is the only use in that building. <p>The stairways do not appear to comply with the requirements of this Clause.</p> <div style="text-align: center;">  </div> <p>Compliance can be achieved via a fire engineering performance solution undertaken prior to the issue of the Construction Certificate. Please refer to Clause D2D12 and Clause D2D14 for further details.</p>



Part D2 – Provision for Escape			
Clause	Description	Status	Comments
D2D5	Exit travel distances	CRA	<p>No point on a floor of a Class 9 building must be more than 20 m from an exit, or a point from which travel in different directions to 2 exits is available, in which case the maximum distance to one of those exits must not exceed 40 m.</p> <p>In a Class 9b building other than a school or early childhood centre, the distance to one of the exits may be 60 m if:</p> <ul style="list-style-type: none"> the path of travel from the room concerned to that exit is through another area which is a corridor, hallway, lobby, ramp or other circulation space; and the room is smoke-separated from the circulation space by construction having an FRL of not less than 60/60/60 with every doorway in that construction protected by a tight fitting, self-closing, solid-core door not less than 35 mm thick; and the maximum distance of travel does not exceed 40 m within the room and 20 m from the doorway to the room through the circulation space to the exit. <p>Travel distances in the building appear to comply with the requirements of this clause.</p> <p>Design verification to be provided by the designer prior to the issue of the Construction Certificate.</p>
D2D6	Distances between alternative exits	CRA	<p>Storeys requiring two or more exits, must have exits distributed within 60m for the Class 7a and 9b parts of the building from one another and are also not less than 9m apart. The paths of travel leading to alternative exits must not converge within 6m.</p>
D2D7	Height of exits, paths of travel to exits and doorways	CRA	<p>In a required exit or path of travel, the unobstructed height throughout must be not less than 2m, except the unobstructed height of any doorway must be reduced to not less than 1980mm.</p> <p>Height of exits, paths of travel and doorways in the building appear to comply with the requirements of this clause.</p> <p>Design verification to be provided by the designer prior to the issue of the Construction Certificate.</p>
D2D8	Width of exits and paths of travel to exits	CRA	<p>The unobstructed width of each exit or path of travel to an exit, except for ladders and doorways, must not be less than 1m.</p> <p>Note: all service and common areas such as the residential bin storage room are required to be provided with a clear exit width of 1m.</p> <p>Non-Fire Isolated Stairways and Ramps</p> <p>All non- fire isolated stairways and ramps serving the building must include double handrails and tactile indicators in accordance with AS 1428.1-2009.</p> <p>Please note: Internal non-fire isolated stairs must incorporate double handrail as required under D4, stairs are to be >1.2m wide to cater for this requirement.</p>



Part D2 – Provision for Escape			
Clause	Description	Status	Comments
			<p>Width of exits and paths of travel in the building appear to comply with the requirements of this clause.</p> <p>Design verification to be provided by the designer prior to the issue of the Construction Certificate.</p>
D2D9	Width of doorways in exits or paths of travel to exits	CRA	<p>The unobstructed width of a doorway in a required exit or path of travel to exit must not be less than 750mm.</p> <p>Width of doorways in paths of travel in the building appear to comply with the requirements of this clause.</p> <p>Design verification to be provided by the designer prior to the issue of the Construction Certificate.</p>
D2D10	Exit width not to diminish in direction of travel	CRA	<p>The unobstructed width of a required exit must not diminish in the direction of travel to a road or open space.</p> <p>Design verification to be provided by the designer prior to the issue of the Construction Certificate.</p>
D2D11	Determination and measurement of exits and paths of travel to exits	CRA	<p>The unobstructed width of a stairway or ramp in a required exit or path of travel to an exit must be measured clear of all obstructions such as handrails, projecting parts of balustrades or other barriers and the like.</p> <p>The unobstructed height of a stairway or ramp in a required exit or path of travel to an exit must extend without interruption, except for ceiling cornices, to a height not less than 2m vertically above a line along the nosing of the treads or the floor surface of the ramp or landing.</p> <p>Design verification to be provided by the designer prior to the issue of the Construction Certificate.</p>
D2D12	Travel via fire-isolated exits	Noted	The current design proposes no fire-isolated exits.
D2D13	External stairways or ramps in lieu of fire-isolated exits	N / A	The building design proposes no external stairways in lieu of fire-isolated exits.
D2D14	Travel by Non-fire-isolated Stairways or ramps	CRA	<p>A required non-fire-isolated stairway or ramp must provide a continuous means of travel by its own flights and landings from every storey served to the level at which egress to a road or open space is provided.</p> <p>A required non-fire-isolated stairway or ramp servicing the carpark must discharge at a point not more than 20 m from a road or open space or from a fire-isolated passageway leading to a road or open space.</p> <p>In a Class 9b building, the distance from any point on a floor to a point of egress to a road or open space by way of a required non-fire-isolated stairway or non-fire isolated ramp must not exceed 80 m.</p> <p>In a 9b building, a required non-fire-isolated stairway or non-fire-isolated ramp must discharge at a point not more than—</p>

Part D2 – Provision for Escape			
Clause	Description	Status	Comments
			<ul style="list-style-type: none"> • 20 m from a doorway providing egress to a road or open space or from a fire-isolated passageway leading to a road or open space; or • 40 m from one of 2 such doorways or passageways if travel to each of them from the non-fire-isolated stairway or non-fire-isolated ramp is in opposite or approximately opposite directions. <p>Details verifying compliance must be provided on plans prior to the issue of a Construction Certificate.</p>
D2D15	Discharge from exits	CRA	<p>Suitable barriers such as bollards are to be provided to prevent the blockage of exits by vehicles, etc.</p> <p>All external ramps that are used as a path from an exit to a road must have a gradient not steeper than 1:8 at any part.</p> <p>Details verifying compliance must be provided on plans prior to the issue of a Construction Certificate.</p>
D2D16	Horizontal exits	PS	<p>(1) Horizontal exits must not be counted as required exits -</p> <p>(a) between sole-occupancy units; or</p> <p>(b) in a Class 9b building used as an early childhood centre, primary or secondary school.</p> <p>(3) In cases other than in (2), horizontal exits must not comprise more than half of the required exits from any part of a storey divided by a fire wall.</p> <p>(4) Horizontal exits must have a clear area on the side of the fire wall to which occupants are evacuating, to accommodate the total number of persons (calculated under D2D18) served by the horizontal exit of not less than-</p> <p>(a) 0.2 m² per patient/resident in a Class 9a health-care building or Class 9c aged care building; and</p> <p>(b) 0.5 m² per person in any other case.</p> <p>(5) Where a fire compartment is provided with only two exits, and one of those exits is a horizontal exit, the clear area required by (4) is to be of a size that accommodates all the occupants from the fire compartment being evacuated.</p> <p>(6) in a Class 9b early childhood centre, the clear area required by (4) must accommodate all occupants of the early childhood centre.</p> <p>(7) The clear area required by (4) must be connected to the horizontal exit by an unobstructed path that has at least the dimensions required for the horizontal exit and may include the area of the unobstructed path.</p> <p>(8) Each fire compartment required by C3D6(2) must be served by not less than 2 horizontal exits, each located not less than 9m from-</p> <p>(a) at least one other horizontal exit; and</p> <p>(b) an exit other than a horizontal exit.</p>



Part D2 – Provision for Escape			
Clause	Description	Status	Comments
			<p>The Ground and First Floor Levels are not provided with horizontal exits through fire rated walls.</p> <p>Compliance can be achieved via undertaking a fire engineering performance solution prior to the issue of the Construction Certificate.</p>
D2D17	Non-required stairways, ramps or escalators	Noted	
D2D18	Number of persons accommodated	Noted	
D2D19	Measurement of distances	Noted	
D2D20	Method of measurement	Noted	
D2D21	Plant rooms, lift machine rooms and electricity network substations: Concession	N / A	
D2D22	Access to lift pits	CRA	Final details as to the lift shafts and pits are required.
<div style="border: 1px solid black; padding: 5px; background-color: #f0f0f0;"> <p>DANGER: LIFTWELL ENTRY OF UNAUTHORISED PERSONS PROHIBITED KEEP CLEAR AT ALL TIMES</p> </div>			<p>(a) where the pit depth is not more than 3 m, be through the lowest landing doors; or</p> <p>(b) where the pit depth is more than 3 m, be provided through an access doorway complying with the following:</p> <ul style="list-style-type: none"> (i) In lieu of D2D7 to D2D11, the doorway must be level with the pit floor and not be less than 600 mm wide by 1980 mm high clear opening, which may be reduced to 1500 mm where it is necessary to comply with (ii). (ii) No part of the lift car or platform must encroach on the pit doorway entrance when the car is on a fully compressed buffer. (iii) Access to the doorway must be by a stairway complying with AS 1657. (iv) In lieu of D3D26, doors fitted to the doorway must be— <ul style="list-style-type: none"> (A) of the horizontal sliding or outwards opening hinged type; and (B) self-closing and self-locking from the outside; and (C) marked on the landing side with the letters not less than 35 mm high: <p>“DANGER LIFTWELL – ENTRY OF UNAUTHORIZED PERSONS PROHIBITED – KEEP CLEAR AT ALL TIMES”</p>

Part D2 – Provision for Escape			
Clause	Description	Status	Comments
D2D23	Egress from primary schools	PS	<p>Every part of a Class 9b primary school must be wholly within a storey that provides direct egress to a road or open space except in a building with a rise in storeys of 4 or less where the Class 9b primary school is the only use in that building.</p> <p>Compliance can be achieved by a fire engineering performance solution undertaken prior to the issue of the Construction Certificate.</p>

Part D3 – Construction of Exits			
Clause	Description	Status	Comments
D3D1	Deemed-to-Satisfy Provisions	-	-
D3D2	Application of Part	Noted	
D3D3	Fire-isolated stairways and ramps	Noted	No fire isolated exits proposed in the current design.
D3D4	Non-fire-isolated stairways and ramps	CRA	<p>Required stairs that are not required to be within a fire-resting shaft are to be constructed of concrete, steel (6mm), or timber (44mm) of specified minimum dimensions.</p> <p>Engineering details are to be submitted with the Construction Certificate Documentation.</p>
D3D5	Separation of rising and descending stair flights	Noted	No fire isolated exits proposed in the current design.
D3D6	Open access ramps and balconies	N / A	
D3D7	Smoke lobbies	N / A	
D3D8	Installations in exits and paths of travel	CRA	<p>Electrical boards and the like are to be located within and enclosed by non-combustible construction or have a fire-protective covering with the doorway suitably sealed against smoke spreading from the enclosure.</p> <p>Fire-Isolated Stairways</p> <p>No services or piping, other than the equipment and pipework required for the essential fire safety services, are to be provided within any of the fire isolated exits within the building (including rooms and storage throughout). Architect to cross-check all designer/engineering drawings to confirm.</p>

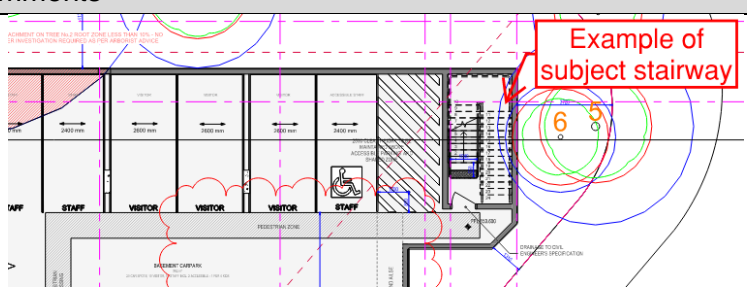
Part D3 – Construction of Exits			
Clause	Description	Status	Comments
			 <p>Design verification is to be provided prior to the issue of the Construction Certificate.</p>
D3D9	Enclosure of space under stairs and ramps	CRA	<p>The space below required fire-isolated stairs must not be enclosed to form a cupboard or similar enclosed space. The space below required non-fire-isolated stairs must not be enclosed unless the enclosing walls have an FRL of not less than 60/60/60 and any doorway to the enclosed space is fitted with a self-closing –/60/30 fire door.</p> <p>Design verification is to be provided prior to the issue of the Construction Certificate.</p>
D3D10	Width of required stairways and ramps	Noted	<p>Stairway width is to be measured clear of obstructions such as handrails, projecting parts of balustrades or other barriers and the like and extend to a height of not less than 2m.</p>
D3D11	Pedestrian ramps	CRA	<p>Ramps serving as a required exit must not have a gradient steeper than 1:8. If the ramp is required for disabled access under Part D4 it must comply with AS1428.1. The surface of the ramp must have a non-slip finish.</p> <p>Note: The floor surface of a ramp must have a slip-resistance classification not less than that listed in Table D3D15 of the BCA when tested in accordance with AS 4586-2013.</p>
D3D12	Fire-isolated passageways	Noted	<p>No fire isolated exits proposed in the current design.</p>
D3D13	Roof as open space	N / A	
D3D14	Goings and risers	CRA	<p>Stairs are to have risers measuring between 115-190mm and goings between 250-355.</p> <p>Goings and Risers are to satisfy the equation of $2R+G=700(\text{max})$ and $550(\text{min})$.</p> <p>Goings and risers are to be consistent throughout in one flight. Any gap between risers must not permit a 125mm sphere to pass through it.</p> <p>Ensure all stairways throughout the building do not contain less than 2 or more than 18 risers.</p> <p>All treads and surfaces with a slip resistant classification are to be fitted with non-slip finish or non-skid strips compliant with the requirements of Table D3D15 when tested in accordance with AS4586-2013 and 30% colour contrasting nosings.</p>

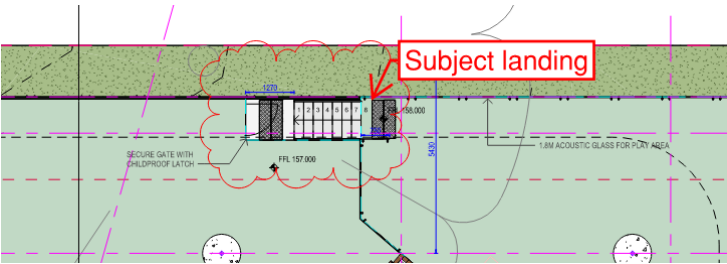
Part D3 – Construction of Exits																		
Clause	Description	Status	Comments															
			Final details are to be submitted with the Construction Certificate Documentation.															
D3D15	Landings	CRA	<p>Landings must comply with the requirements of Clause D3D15 of the BCA. Landings must be not less than 750mm long and have a non-slip finish throughout or an adequate non-skid strip near the edge of the landing where it leads to a flight below and 30% colour contrasting nosings.</p> <p>Strips at the edge of the landing with slip-resistance classification not less than that listed in Table D3D15 when tested in accordance with AS 4586-2013, where the edge leads to a flight below.</p> <p>Table D3D15: Slip-resistance classification</p> <table border="1"> <thead> <tr> <th>Application</th> <th>Dry Surface conditions</th> <th>Wet surface conditions</th> </tr> </thead> <tbody> <tr> <td>Ramp steeper than 1:14</td> <td>P4 or R11</td> <td>P5 or R12</td> </tr> <tr> <td>Ramp steeper than 1:20 but not steeper than 1:14</td> <td>P3 or R10</td> <td>P4 or R11</td> </tr> <tr> <td>Tread or landing surface</td> <td>P3 or R10</td> <td>P4 or R11</td> </tr> <tr> <td>Nosing or landing edge strip</td> <td>P3</td> <td>P4</td> </tr> </tbody> </table> <p>Ground Floor Stairway</p> <p>The external stairway on the Ground Floor Level does not appear to be provided with a landing of 750mm pas the riser on a hard-standing surface.</p>  <p>Compliance can be achieved via slight redesign prior to the issue of the Construction Certificate.</p>	Application	Dry Surface conditions	Wet surface conditions	Ramp steeper than 1:14	P4 or R11	P5 or R12	Ramp steeper than 1:20 but not steeper than 1:14	P3 or R10	P4 or R11	Tread or landing surface	P3 or R10	P4 or R11	Nosing or landing edge strip	P3	P4
Application	Dry Surface conditions	Wet surface conditions																
Ramp steeper than 1:14	P4 or R11	P5 or R12																
Ramp steeper than 1:20 but not steeper than 1:14	P3 or R10	P4 or R11																
Tread or landing surface	P3 or R10	P4 or R11																
Nosing or landing edge strip	P3	P4																
D3D16	Thresholds	CRA	<p>A threshold of a doorway must not incorporate a step or ramp at any point closer to the doorway than the width of the door leaf unless the door opens to a road or open space, external stair landing or external balcony and the doorsill is not more than 190mm above the finished surface of the ground balcony or the like to which the door opens.</p> <p>Final details are to be submitted with the Construction Certificate Documentation.</p>															
<p>Note: If the door is in a path of travel required to be accessible under D4, a step is not allowed.</p> <p>Note: This applies to all Fire Isolated Exit Doors also including the last exit door to open space.</p>																		

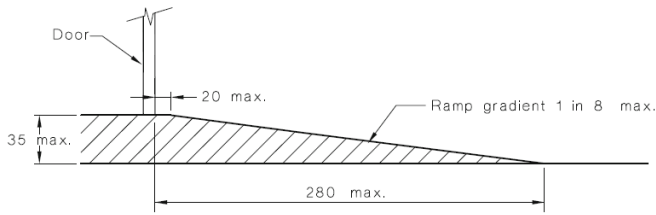
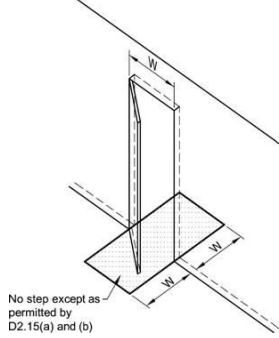
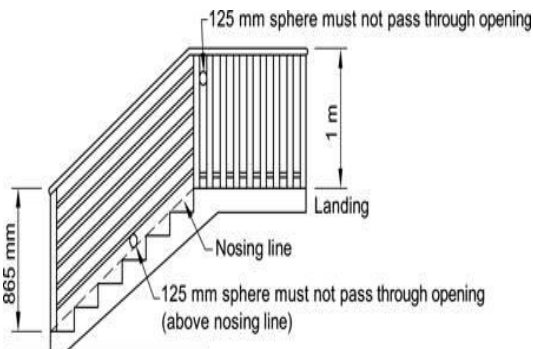
Part D3 – Construction of Exits			
Clause	Description	Status	Comments
 <p>DIMENSIONS IN MILLIMETRES</p> <p>FIGURE 21 THRESHOLD RAMP</p>		 <p>No step except as permitted by D2.15(a) and (b)</p>	
D3D17	Barriers to prevent falls	CRA	<p>Balustrades complying with Deemed-to-Satisfy provisions of the BCA are to be provided where the level of the surface below is 1m or more. Balustrades must also be provided where the level of the surface beneath is more than 4m where it is possible for a person to fall through an openable window.</p> <p>Final details are to be submitted with the Construction Certificate Documentation.</p>
D3D18	Height of barriers	CRA	<p>Where required by D3D17, the height of a barrier must be not less than:</p> <ul style="list-style-type: none"> • For stairways or ramps with a gradient of 1:20 or steeper: 865mm • For landings where the barrier is provided along the inside edge of the landing and does not exceed 500mm in length: 865mm • In front of fixed seating on a mezzanine or balcony in an auditorium in a Class 9b building: 700mm • For all other locations: 1m <p>Final details are to be submitted with the Construction Certificate Documentation.</p>
D3D19	Openings in barriers	CRA	<p>Openings in barriers are required to comply with Clause D3D19.</p>
 <p>125 mm sphere must not pass through opening</p> <p>125 mm sphere must not pass through opening (above nosing line)</p> <p>865 mm</p> <p>1 m</p> <p>Landing</p> <p>Nosing line</p>		<p>Any opening in the balustrade must not permit a 125mm sphere to pass through the balusters.</p> <p>Details demonstrating compliance with this clause must be incorporated into the architectural drawings prior to the issue of a Construction Certificate.</p>	



Part D3 – Construction of Exits			
Clause	Description	Status	Comments
D3D20	Barrier climbability	CRA	<p>Balustrades must be constructed to comply with Clause D3D20.</p> <p>Where the level of the surface below is 4m or more, a balustrade or other barrier must not facilitate climbing of horizontal elements between 150mm and 760mm above the floor.</p> <p>Potentially climbable elements close to balustrades must be relocated or appropriately protected.</p> <p>Details demonstrating compliance with this clause must be incorporated into the architectural drawings prior to the issue of a Construction Certificate.</p>
D3D21	Wire barriers	CRA	<p>Wire balustrades must be constructed to comply with Clause D3D17–D3D21 and Tables D3D21a, D3D21b and D3D21c.</p> <p>Details demonstrating compliance with this clause must be incorporated into the architectural drawings prior to the issue of a Construction Certificate.</p>
D3D22	Handrails	CRA	<p>Handrails are to be provided to at least one side of stair flights within fire isolated stairs and both side in any other case (See D4) and located not less than 865mm above the nosings of stair treads and the floor surfaces of landings.</p> <p>In a Class 9b building used as a primary school or a building that contains an early childcare centre, an additional fixed handrail is required to be provided for children.</p> <p>Details demonstrating compliance with this clause must be incorporated into the architectural drawings prior to the issue of a Construction Certificate.</p>
D3D23	Fixed platforms, walkways, stairways and ladders	CRA	<p>Fixed platforms, walkways, stairways, ladders, landings, handrails, balustrades and any tread or riser in a plant room, lift motor room or the like is to comply with AS1657.</p>
D3D24	Doorways and doors	CRA	<p>A doorway serving as a required exit or forming part of a required exit:</p> <ul style="list-style-type: none"> • must not be fitted with a revolving door; and • must not be fitted with a roller shutter or tilt-up door unless— <ul style="list-style-type: none"> ○ it serves a Class 6, 7 or 8 building or part with a floor area not more than 200 m²; and ○ the doorway is the only required exit from the building or part; and • it is held in the open position while the building or part is lawfully occupied; and • must not be fitted with a sliding door unless— <ul style="list-style-type: none"> ○ it leads directly to a road or open space; and ○ the door is able to be opened manually under a force of not more than 110 N; and • if fitted with a door which is power-operated—

Part D3 – Construction of Exits			
Clause	Description	Status	Comments
			<ul style="list-style-type: none"> ○ it must be able to be opened manually under a force of not more than 110 N if there is a malfunction or failure of the power source; and ○ if it leads directly to a road or open space it must open automatically if there is a power failure to the door or on the activation of a fire or smoke alarm anywhere in the fire compartment served by the door. <p>Details demonstrating compliance with this clause must be incorporated into the architectural drawings prior to the issue of a Construction Certificate.</p>
D3D25	Swinging doors	CRA	<p>A swinging door in a required exit or forming part of a required exit must not encroach more than 500 mm on the required width of a required stairway, ramp or passageway if it is likely to impede the path of travel of the people already using the exit.</p> <p>Furthermore, such a swinging door must swing in the direction of egress, unless it serves a sanitary compartment, airlock or is the only required exit serving a building part with floor area not more than 200m² and is fitting with hold open device.</p> <p>Design verification to be provided prior to the issue of the Construction Certificate.</p>
D3D26	Operation of latch	CRA	<p>The latch of a door in a required exit, forming part of a required exit or in the path of travel is to be readily openable without a key from the side of that faces a person seeking egress. It is to have a single downward action or pushing action and to be located between 900mm and 1100mm from the floor.</p> <p>Where the latch operation referred to above is not located on the door leaf itself, manual controls to power-operated doors must be at least 25mm wide, proud of the surrounding surface located not less than 500mm from an internal corner, and:</p> <ul style="list-style-type: none"> ● for a hinged door located between 1m and 2m from the door leaf in any position, or ● for a sliding door located within 2m of the doorway and clear of a surface mounted door in the open position. <p>Design verification to be provided prior to the issue of the Construction Certificate.</p>

Part D3 – Construction of Exits

Clause	Description	Status	Comments
--------	-------------	--------	----------

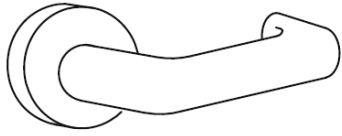

(a) Isometric view

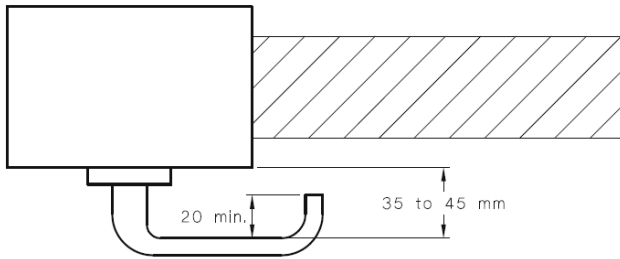

(b) Plan view

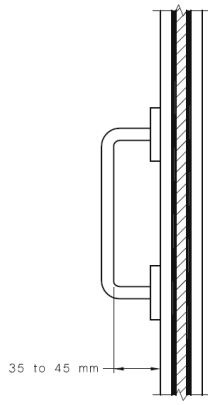

SECTIONAL ELEVATION

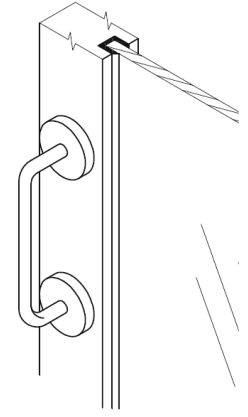

ISOMETRIC VIEW

FIGURE 35(A) EXAMPLE OF ACCEPTABLE DOOR HARDWARE FOR HINGED DOORS

D3D27	Re-entry from fire-isolated exits	N / A	
D3D28	Signs on doors	CRA	<p>Fire Door and Smoke Door signage is required to be provided to all doors giving access to and egress from the fire isolated stairways.</p> <p>NOTE: Braille Exit Level Signs are to be Installed at Each Exit Also. D4D7</p>

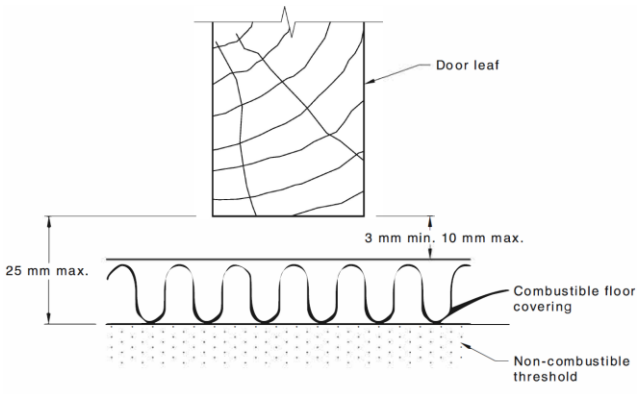
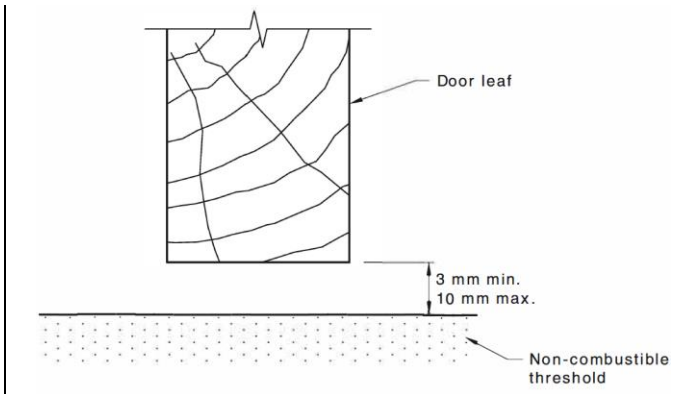
Part D3 – Construction of Exits			
Clause	Description	Status	Comments
	<p>FIRE SAFETY DOOR DO NOT OBSTRUCT DO NOT KEEP OPEN</p> <p>FIRE SAFETY DOOR DO NOT OBSTRUCT</p> <p>WARNING: SLIDING FIRE DOOR</p> <p>OFFENCES RELATING TO FIRE EXITS</p> <p>By virtue of the regulations under the Environmental Planning And Assessment Act 1979, it is an offence:</p> <p>(a) to place anything in this exit that may impede the free passage of persons, or</p> <p>(b) to interfere with or cause obstruction or impediment to, the operation of the doors providing access to this exit, or</p> <p>(c) to remove, damage or otherwise interfere with this notice.</p>		<p>Any Fire Door require the standard signage, “Fire Safety Door, Do not Obstruct, Do Not Keep Open etc ” along with the EP& A Notice ;</p> <ul style="list-style-type: none"> – A Fire Door on a auto-closing or fire trip is to incorporate the following wording: “FIRE SAFETY DOOR—DO NOT OBSTRUCT” – A Self-Closing Fire Doors are to incorporate the following wording: “FIRE SAFETY DOOR —DO NOT OBSTRUCT —DO NOT KEEP OPEN” – For the last door discharging from a fire isolated exit, (Door opening on to open space/outside) – “FIRE SAFETY DOOR—DO NOT OBSTRUCT”. <p>Along with the required BCA signage, the EPA & A Regulations require a warning notice to be displayed in a conspicuous position adjacent to a doorway providing access to, but not within, that stairway, passageway or ramp:</p> <ul style="list-style-type: none"> – OFFENCE RELATING TO FIRE EXITS <p>It is an offence under the Environmental Planning and Assessment Act 1979:</p> <p>(a) to place anything in or near this fire exit that may obstruct persons moving to and from the exit, or</p> <p>(b) to interfere with or obstruct the operation of any fire doors, or</p> <p>(c) to remove, damage or otherwise interfere with this notice.</p>
	<p>All fire doors and frames are to be tagged in accordance with AS 1905.1-2015 and a complete door schedule is to be provided at the Occupation Certificate Stage.</p>		<p>FIRE DOORFRAME (DOOR LEAF)—TO AS 1905.1:XXXX FRL -/60/30 MANUFACTURED BY (BUSINESS NAME) DOORSET CERTIFIER—(BUSINESS/INDIVIDUAL NAME) DOOR NUMBER YEAR OF MANUFACTURE</p>
	<p>Clearances under and the side of fire doors are to be in accordance with AS 1905.1-2015</p>		 <p>(a) With a combustible floor covering</p>  <p>(b) Without a combustible floor covering</p>



Part D3 – Construction of Exits

Clause	Description	Status	Comments
--------	-------------	--------	----------

(Company Name)
FIRE DOOR CERTIFICATE
Certificate Number 12345

Project Name:

Building Owner/
Representative:

Building Address:

The member company nominated certifies the following:

- The fire doorsets installed in this building comply with AS 1905.1:XXXX.
- The fire doorsets are labelled as required by the appropriate regulatory authorities in accordance with Australian Standard AS 1905.1:XXXX.
- A manual dealing with the fire-resistant doorsets installed in this building has been completed in accordance with AS 1905.1:XXXX.
- A paper-based copy of the manual has been provided to the building owner/representative.

Certified by: Member Company

Name of Certifier:

Signature:

Date:

Fire Resistant Doorset—Schedule of Evidence						
Project name:				Date of installation:		
Building address:						
Building owner/ representative:				Date of certification:		
Door identification number						
Door location						
Door leaf type and manufacturer						
Door facing and edging material						
Door dimensions		Width	Height	Thickness		
Frame type and manufacturer						
Frame fixing and backfill material						
Wall type and FRL						
Doorset FRL						
Doorset hardware						
Lock	Make	Model	Type	Materials on leaf	Materials on frame	FRL
Furniture	Make	Model	Type	Materials on leaf	Materials on frame	FRL
Fixtures	Make	Model	Type	Materials on leaf	Materials on frame	FRL
Fittings	Make	Model	Type	Materials on leaf	Materials on frame	FRL
Vision panel	Make	Model	Type	Materials on leaf	Materials on frame	FRL
XXXX	Make	Model	Type	Materials on leaf	Materials on frame	FRL
Test report references						
Assessment report references						
Date of final inspection		Certificate No.		Inspecting officer		Thickness
Date of Certification			Doorset Certifier's Name and (if applicable) Licence No.		Doorset Certifier's Business Name	
Operating and maintenance information						
Doorframe						
Doorset						
Lock						
Furniture						
Fixtures						
Fittings						
Vision panel						



Part D3 – Construction of Exits			
Clause	Description	Status	Comments
D3D29	Protection of openable windows	CRA	<p>All window openings throughout the development must be provided with protection, if the floor below the window is 2m or more above the surface beneath in a Class 9b early childhood centre.</p> <p>Where the lowest level of the window opening is less than 1.7m above the floor, the operable portion of the window must be protected with a device capable of restricting the window opening or a screen with secure fittings.</p> <p>A device or screen must:</p> <ul style="list-style-type: none">• Not permit a 125mm sphere to pass through the window opening or screen;• Resist an outward horizontal action of 250N against the window restraining device or screen protecting the opening; and• Have a child restraint release mechanism if the screen or device is able to be removed, unlocked or overridden. <p>A barrier with a height not less than 865mm above the floor is required to an openable window in addition to window protection, when a child resistant release mechanism is required and where the floor below the window is 4m or more above the surface beneath if the window is not provided with protection. The barrier must not permit a 125mm sphere to pass through it and must not contain any horizontal or near horizontal elements between 150mm and 760mm above the floor that facilitate climbing.</p> <p>Details demonstrating compliance with this clause must be incorporated into the architectural drawings prior to the issue of a Construction Certificate.</p>
D3D30	Timber stairways: Concession	N / A	
NSW D3D31	Doors of travel in an entertainment venue	N / A	

Part D4 – Access for People with Disabilities			
Clause	Description	Status	Comments
D4D1	Deemed-to-Satisfy Provisions	Note	Disability (Access to Premises — Buildings) Standards 2010 is to be read in conjunction with the BCA.
D4D2	General Building Access Requirements	CRA	<p>Buildings and parts of buildings must be accessible as required by D4D2, unless exempted by D4D5.</p> <p>Compliance with Part D4 of the BCA is applicable to this building.</p> <p>All common areas throughout the building are to be accessible in accordance with AS1428.1.</p> <p>Access into the ground and first floors is required to be 100% wheelchair accessible, with the exception of areas exempt by Clause D4D5 of the BCA.</p> <p>Common Areas</p> <p>Clause D4D2 requires access to and within not less than one of each type of room or space for use in common by residents. In Class 9b portions of the building, access is required to and within all areas normally used by the occupants.</p> <p>Final design details of wheelchair access to this part are to be provided at the final Construction Certificate stage.</p>
<p><i>Architects/Designers Note: AS1428.1 is very detailed, please ensure that your design has been checked and rechecked as to full compliance .i.e.:</i></p> <ul style="list-style-type: none"> - All doors are to be a minimum of a clear opening width of not less than 850 mm and the required circulation spaces around doors to be accessible in accordance with AS 1428.1 - Door hardware is to a 'D' grasping style, 20N force to open and close all doors. - Walkways, corridors also must be compliant for dead areas, wheelchair passing and splayed corners. - Doors and doorways need to have 30% luminance contrasting to distinguish door locations, - All Glazing other than windows needs 30% luminance contrasting, The contrasting line shall be not less than 75 mm wide and shall extend across the full width of the glazing panel. The lower edge of the contrasting line shall be located between 900 mm and 1000 mm above the plane of the finished floor level. Any contrasting line on the glazing shall provide a minimum of 30% luminance contrast when viewed against the floor surface or surfaces within 2 m of the glazing on the opposite side. - All stairs excluding the fire isolated stair are to incorporate the required double handrail, downturns, solid treads, colour contrast nosing strips and TGSI's. <p><i>Floor surfaces and junction points are all smooth and comply with slip resistant levels.</i></p>			

Part D4 – Access for People with Disabilities

Clause	Description	Status	Comments
--------	-------------	--------	----------

Door Circulation Spaces

All circulation spaces through doors to areas required to be accessible are to be confirmed with minimum 850mm door clearance required for accessible doors throughout; the doorways serving Indoor Playroom 0-2 Yrs and the accessible WC on the Ground Floor appear not to meet the set dimensions under AS1428.1 and requires review.

Compliance can be achieved via slight redesign prior to the issue of the Construction Certificate.

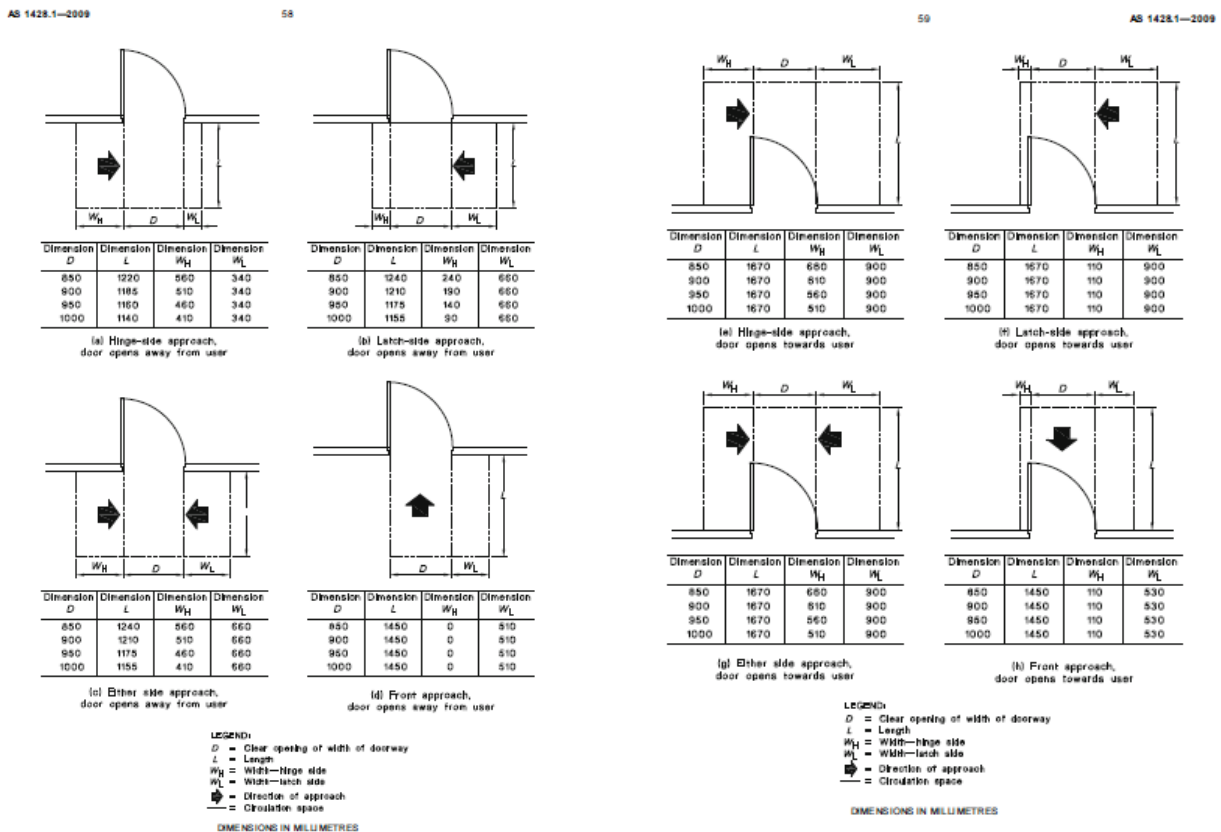

FIGURE 31 (in part) CIRCULATION SPACES AT DOORWAYS WITH SWINGING DOORS

FIGURE 31 (in part) CIRCULATION SPACES AT DOORWAYS WITH SWINGING DOORS

D4D3	Access to Buildings	CRA	<p>An accessway/s has been provided from Principal Pedestrian Entry (PPE) areas.</p> <p>The use of a platform lift in accordance with AS 1735.14 Low-rise platform lift is allowed for this building and is limited to 1m.</p> <p>All doors are to be a minimum of a clear opening width of not less than 850 mm and the required circulation spaces around doors to be accessible in accordance with AS 1428.1 including SOU doors to storey serviced via a lift.</p> <p>All stairs excluding fire isolated stairs are to incorporate the required double handrail, downturns, colour contrast nosing strips and TGS's.</p> <p>Final design details of wheelchair access to this part are to be provided at the final Construction Certificate stage.</p>
------	---------------------	-----	------------------------------------------------------------------------------------------------------------------------------------------------------------------------------------------------------------------------------------------------------------------------------------------------------------------------------------------------------------------------------------------------------------------------------------------------------------------------------------------------------------------------------------------------------------------------------------------------------------------------------------------------------------------------------------------------------------------------------------------------------------

Part D4 – Access for People with Disabilities

Clause	Description	Status	Comments
D4D4	Parts of Buildings to be accessible	CRA	Final details to be provided detailing floor services and materials are to be provided at the Construction Certificate stage or noted on the plans.

Passing Spaces

Passing Spaces for Wheelchairs are to be provided in corridors longer than 20m.

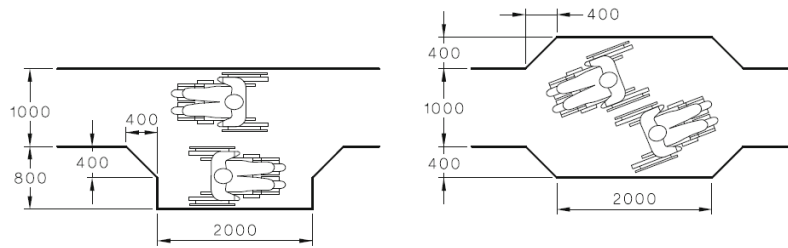

Turning Spaces & Dead End Zones

The subject turning spaces and dead-end zones within accessways appear to comply with the requirements of AS1428.1-2009.

Design verification to be provided prior to the issue of the Construction Certificate.

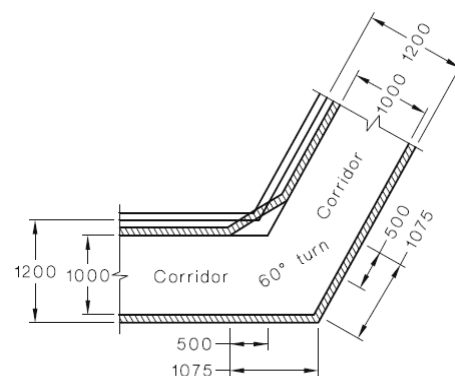
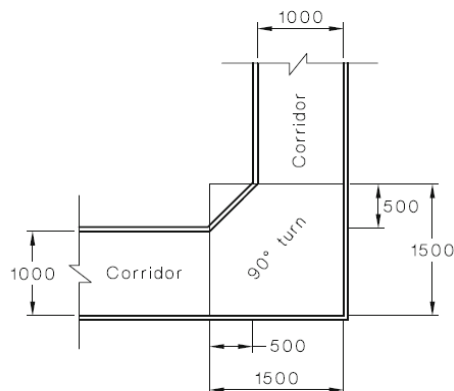
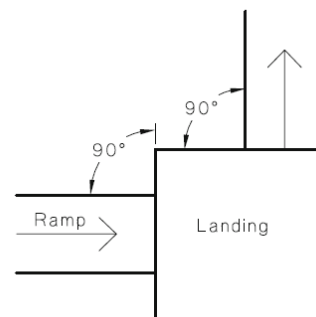
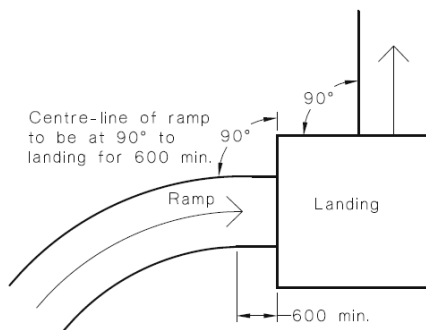

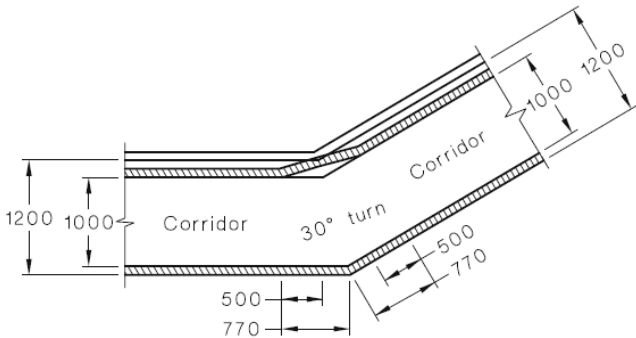
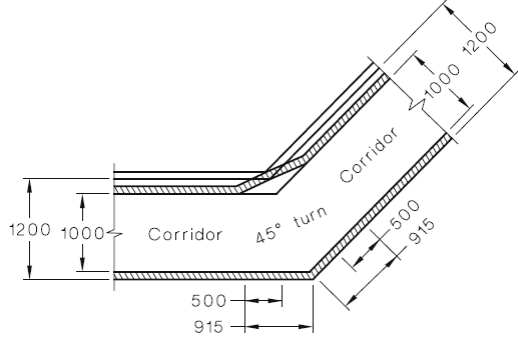
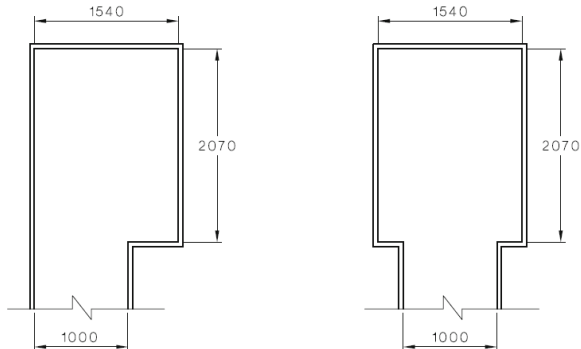
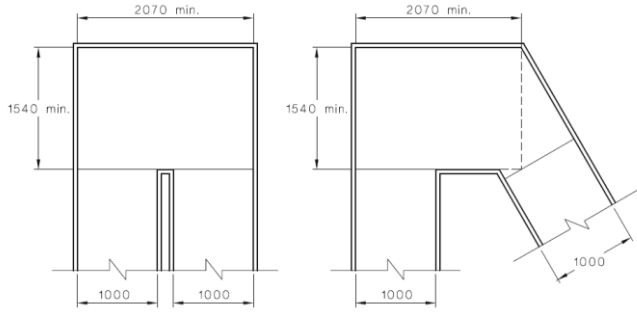
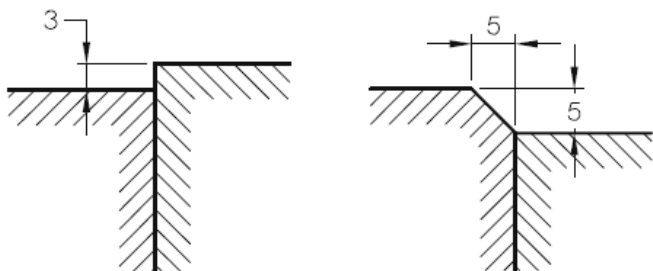
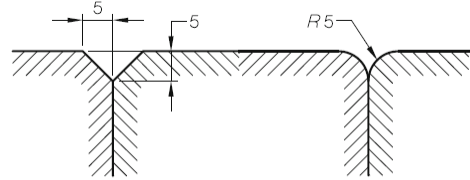
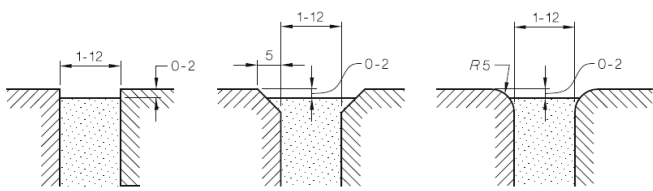
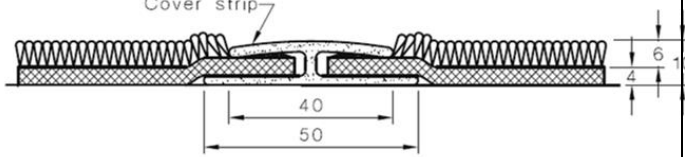
Part D4 – Access for People with Disabilities			
Clause	Description	Status	Comments
			
			
	<p>All finished floor surfaces are to be trip free, the following details demonstrate the tolerance level for floor finishes.</p>		
	 <p>(a) Change in level</p>		 <p>(b) Continuous paving units—flush-jointed with level surfaces</p>
	 <p>(a) Continuous paving units—Level surface</p>		
	<p>Note: BCA Clause D4D4 changes the above to 11mm, 4mm and 15mm respectively.</p>		

Part D4 – Access for People with Disabilities

Clause	Description	Status	Comments
--------	-------------	--------	----------

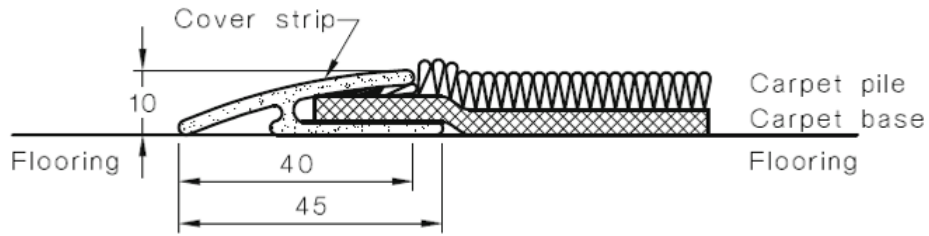

Note: BCA Clause D4D4 changes the above to 11mm, 4mm and 15mm respectively.

Handrail Extensions

Any non-fire isolated stairways or ramps are required to include double handrails which extend 300mm from the top of the stairway or ramp and 600mm from the base in accordance with AS 1428.1-2009.

Design verification to be provided prior to the issue of the Construction Certificate.

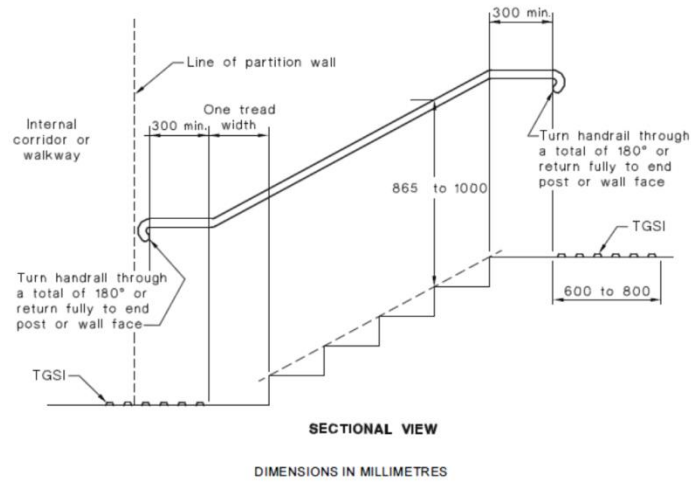
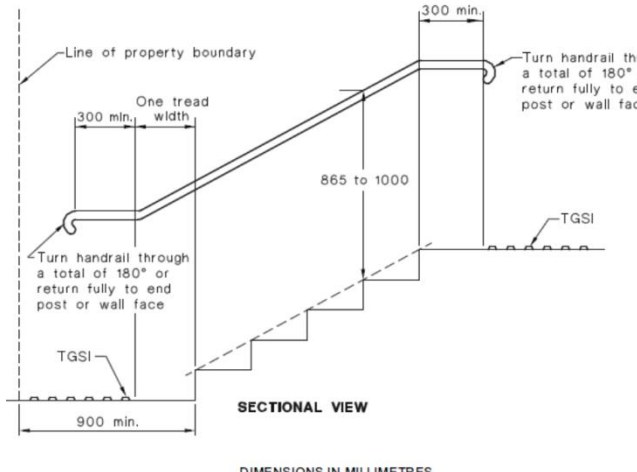
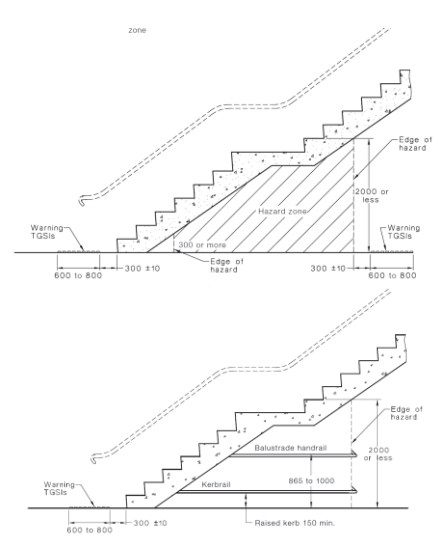

FIGURE 26(B) STAIRWAY LOCATION AND HANDRAIL EXTENSIONS AT END OF STAIRWAY OTHER THAN AT LINE OF BOUNDARY

As Occupants may pass under these stairs, they must be obstructed or have TGSIs installed to warn of over head obstructions.

Part D4 – Access for People with Disabilities

Clause	Description	Status	Comments
	 <p>SECTIONAL VIEW DIMENSIONS IN MILLIMETRES</p> <p>FIGURE 26(A) STAIRWAY LOCATION AND HANDRAIL EXTENSIONS AT BOUNDARY</p>		

Tactile or TGSi's are to be installed correctly to all stairs and ramps. These TGSi's are to be re-installed to the correct distance from the nosing and the height from the FFL.

The floor surface is to be cut to allow the TGSi mat to be fixed to the slab and provide the correct height.

Stairways & Ramps

Any non-fire isolated stairways or ramps are required to include double handrails and tactiles in accordance with AS 1428.1-2009. As such, the external non-fire isolated stairways on the Ground Floor Level requires review.

Compliance can be achieved via slight redesign prior to issue of the Construction Certificate.

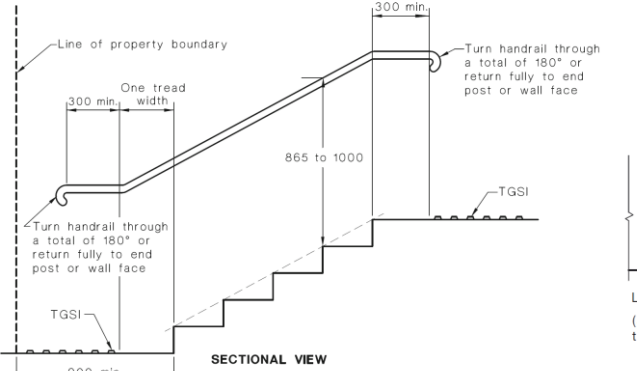
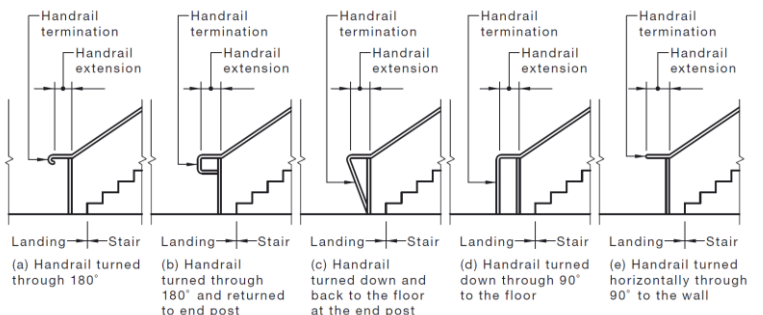
 <p>SECTIONAL VIEW</p>	 <p>(a) Handrail turned through 180° (b) Handrail turned through 180° and returned to end post (c) Handrail turned down and back to the floor at the end post (d) Handrail turned down through 90° to the floor (e) Handrail turned horizontally through 90° to the wall</p>
------------------------------------------------------------------------------------------------------------------	----------------------------------------------------------------------------------------------------------------------------------------------------------------------------------------------------------------------------------------------------------------------------------------------------------------------------------------------------------------------------------

Part D4 – Access for People with Disabilities

Clause	Description	Status	Comments
--------	-------------	--------	----------

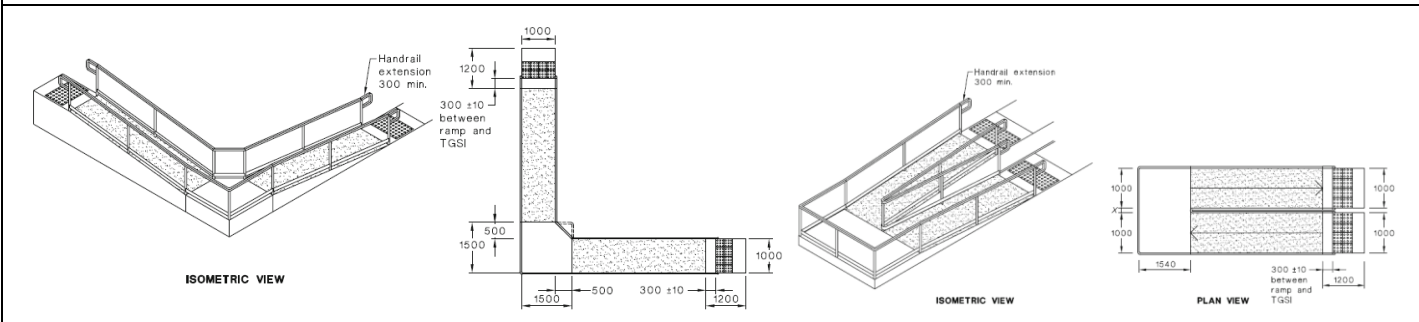
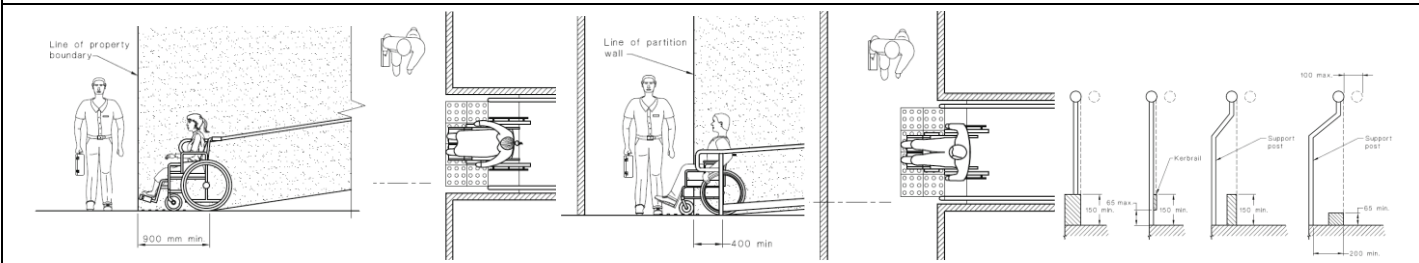
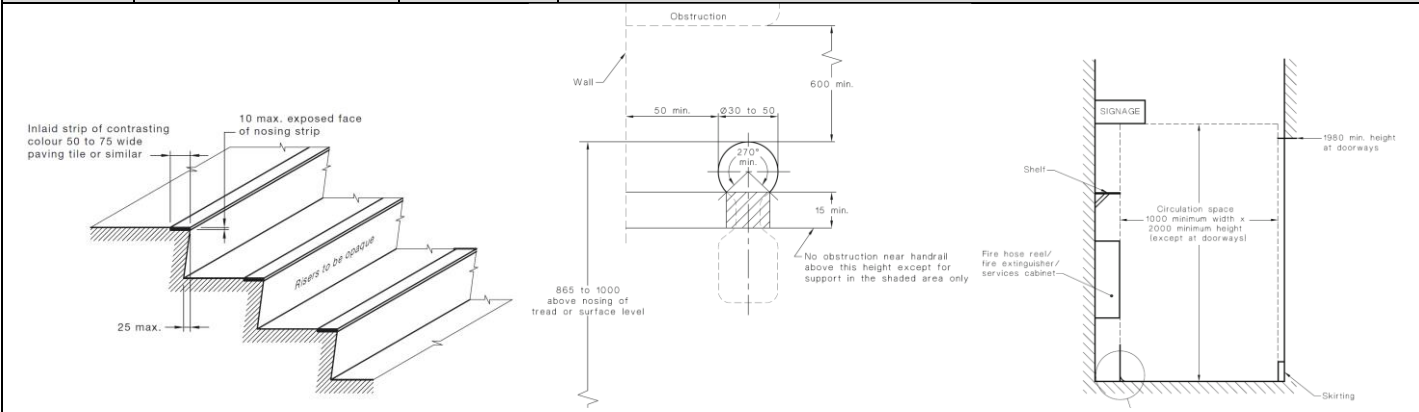

Part D4 – Access for People with Disabilities																																																																											
Clause	Description	Status	Comments																																																																								
<p>Extraction from Standards Australia Handbook 197:1999</p> <p style="text-align: center;">TABLE 3</p> <p style="text-align: center;">PEDESTRIAN FLOORING SELECTION GUIDE – MINIMUM PENDULUM OR RAMP RECOMMENDATIONS FOR SPECIFIC LOCATIONS</p> <table border="1" style="width: 100%; border-collapse: collapse;"> <thead> <tr> <th style="width: 60%;">Location</th> <th style="width: 20%;">Pendulum</th> <th style="width: 20%;">Ramp</th> </tr> </thead> <tbody> <tr><td>External colonnade, walkway and pedestrian crossings</td><td>W</td><td>R10</td></tr> <tr><td>External ramps</td><td>V</td><td>R11</td></tr> <tr><td>Entry foyers hotel, office, public buildings - wet</td><td>X</td><td>R10</td></tr> <tr><td>Entry foyers hotel, office, public buildings - dry</td><td>Z</td><td>R9</td></tr> <tr><td>Shopping centre excluding food court</td><td>Z</td><td>R9</td></tr> <tr><td>Shopping centre – food court</td><td>X</td><td>R10</td></tr> <tr><td>Internal ramps, slopes (greater than 2 degrees) - dry</td><td>X</td><td>R10</td></tr> <tr><td>Lift lobbies above external entry level</td><td>Z</td><td>R9</td></tr> <tr><td>Other separate shops inside shopping centres</td><td>Z</td><td>R9</td></tr> <tr><td>Other shops with external entrances – entry area</td><td>X</td><td>R10</td></tr> <tr><td>Fast food outlets, buffet food servery areas</td><td>X</td><td>R10</td></tr> <tr><td>Hospitals and aged care facilities – dry areas</td><td>Z</td><td>R9</td></tr> <tr><td>Hospital and aged care facilities – ensuites</td><td>X</td><td>A or R10</td></tr> <tr><td>Supermarket aisles except fresh food areas</td><td>Z</td><td>R9</td></tr> <tr><td>Shop and supermarket fresh fruit and vegetable areas</td><td>X</td><td>R10</td></tr> <tr><td>Communal changing rooms</td><td>X</td><td>A</td></tr> <tr><td>Swimming pool surrounds and communal shower rooms</td><td>W</td><td>B</td></tr> <tr><td>Swimming pool ramps and stairs leading into water</td><td>V</td><td>C</td></tr> <tr><td>Toilet facilities in offices, hotels, shopping centres</td><td>X</td><td>R10</td></tr> <tr><td>Undercover concourse areas of sports stadium</td><td>X</td><td>R10</td></tr> <tr><td>Accessible internal stair nosings (dry) – handrails present</td><td>X</td><td>R10</td></tr> <tr><td>Accessible internal stair nosings (wet) – handrails present</td><td>W</td><td>B or R11</td></tr> <tr><td>External stair nosings</td><td>W</td><td>R11</td></tr> </tbody> </table>				Location	Pendulum	Ramp	External colonnade, walkway and pedestrian crossings	W	R10	External ramps	V	R11	Entry foyers hotel, office, public buildings - wet	X	R10	Entry foyers hotel, office, public buildings - dry	Z	R9	Shopping centre excluding food court	Z	R9	Shopping centre – food court	X	R10	Internal ramps, slopes (greater than 2 degrees) - dry	X	R10	Lift lobbies above external entry level	Z	R9	Other separate shops inside shopping centres	Z	R9	Other shops with external entrances – entry area	X	R10	Fast food outlets, buffet food servery areas	X	R10	Hospitals and aged care facilities – dry areas	Z	R9	Hospital and aged care facilities – ensuites	X	A or R10	Supermarket aisles except fresh food areas	Z	R9	Shop and supermarket fresh fruit and vegetable areas	X	R10	Communal changing rooms	X	A	Swimming pool surrounds and communal shower rooms	W	B	Swimming pool ramps and stairs leading into water	V	C	Toilet facilities in offices, hotels, shopping centres	X	R10	Undercover concourse areas of sports stadium	X	R10	Accessible internal stair nosings (dry) – handrails present	X	R10	Accessible internal stair nosings (wet) – handrails present	W	B or R11	External stair nosings	W	R11
Location	Pendulum	Ramp																																																																									
External colonnade, walkway and pedestrian crossings	W	R10																																																																									
External ramps	V	R11																																																																									
Entry foyers hotel, office, public buildings - wet	X	R10																																																																									
Entry foyers hotel, office, public buildings - dry	Z	R9																																																																									
Shopping centre excluding food court	Z	R9																																																																									
Shopping centre – food court	X	R10																																																																									
Internal ramps, slopes (greater than 2 degrees) - dry	X	R10																																																																									
Lift lobbies above external entry level	Z	R9																																																																									
Other separate shops inside shopping centres	Z	R9																																																																									
Other shops with external entrances – entry area	X	R10																																																																									
Fast food outlets, buffet food servery areas	X	R10																																																																									
Hospitals and aged care facilities – dry areas	Z	R9																																																																									
Hospital and aged care facilities – ensuites	X	A or R10																																																																									
Supermarket aisles except fresh food areas	Z	R9																																																																									
Shop and supermarket fresh fruit and vegetable areas	X	R10																																																																									
Communal changing rooms	X	A																																																																									
Swimming pool surrounds and communal shower rooms	W	B																																																																									
Swimming pool ramps and stairs leading into water	V	C																																																																									
Toilet facilities in offices, hotels, shopping centres	X	R10																																																																									
Undercover concourse areas of sports stadium	X	R10																																																																									
Accessible internal stair nosings (dry) – handrails present	X	R10																																																																									
Accessible internal stair nosings (wet) – handrails present	W	B or R11																																																																									
External stair nosings	W	R11																																																																									
D4D5	Exemptions	CRA	<p>The following areas are not required to be accessible:</p> <ul style="list-style-type: none"> • An area where access would be inappropriate because of the particular purpose for which the area is used; • An area that would pose a health or safety risk for people with a disability; and • Any path of travel providing access only to an area exempted by the above. <p>Clause 13.5.3 of AS1428.1-2009 excludes early childhood centres from the standard location of opening and locking controls as regulated by the relevant statutory authority.</p> <p>The Children (Education and Care Services) Supplementary Provisions Regulation 2012 (NSW) restricts unsupervised access to kitchens, nappy changing facilities, entry & exit points, and all equipment (such as light and heating) that may be hazardous to children must be guarded to prevent access by children.</p>																																																																								

Part D4 – Access for People with Disabilities

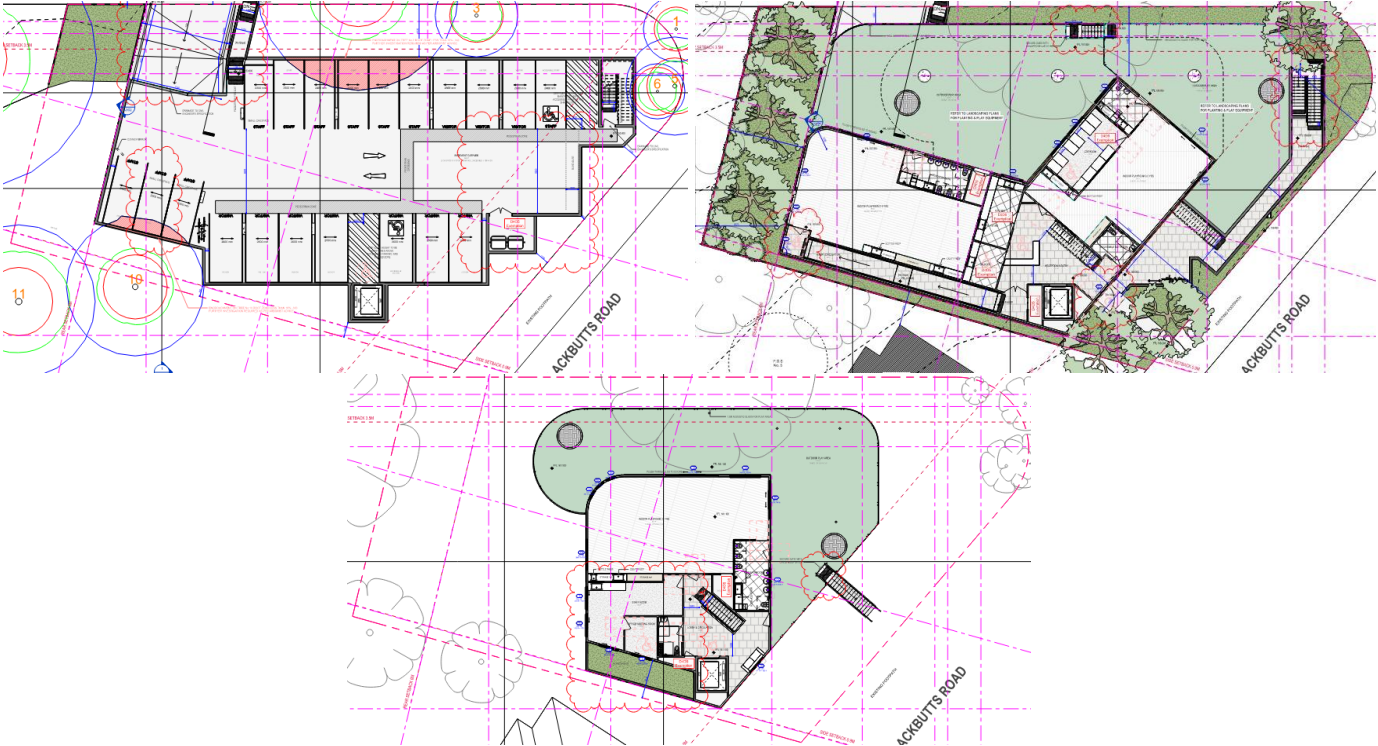

Clause	Description	Status	Comments
<p>Pursuant to the above restrictions, the following laundry, cot, kitchen and store rooms are considered to be exempt under D4D5 for the purposes of this report:</p> <ul style="list-style-type: none"> • Basement Garbage Room; • Ground Floor Storage Room; • Indoor Playroom 0-2 Yrs Cot Room; • Laundry Room; • Kitchen; • Ground Floor External Storage Room; • Indoor Playroom 3 Yrs Storage Room; and • First Floor Storage Room. 			
D4D6	Accessible Carparking	CRA	<p>Car-parking spaces have been provided to the building which are ancillary to the use.</p> <p>At least 1 accessible carparking space is to be provided per 50 spaces under Clause D4D6.</p> <p>The car space still must comply with the space requirements of AS2890.6 form person with a disability.</p>

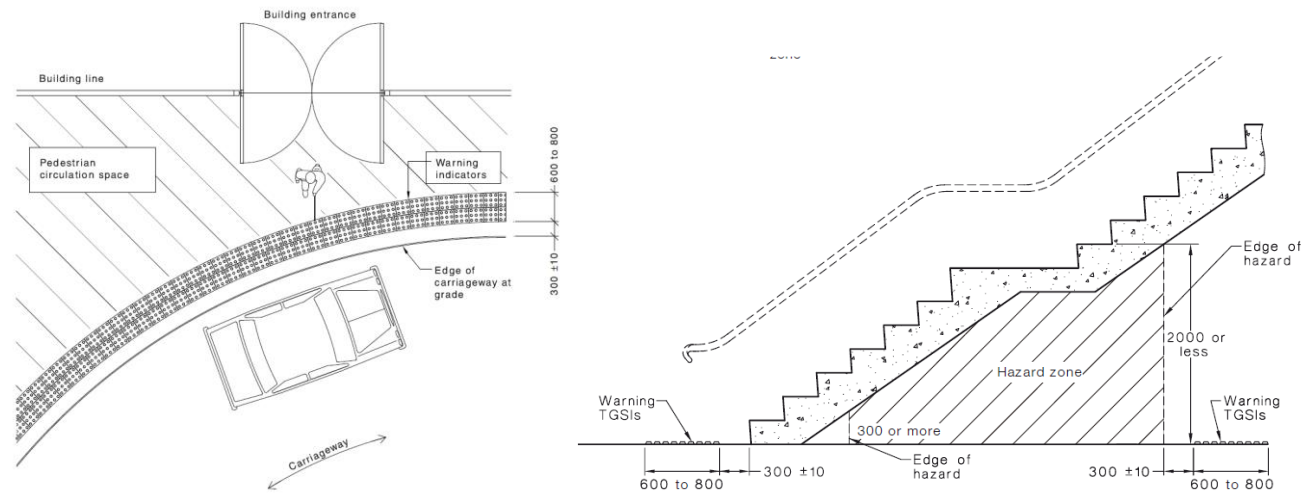
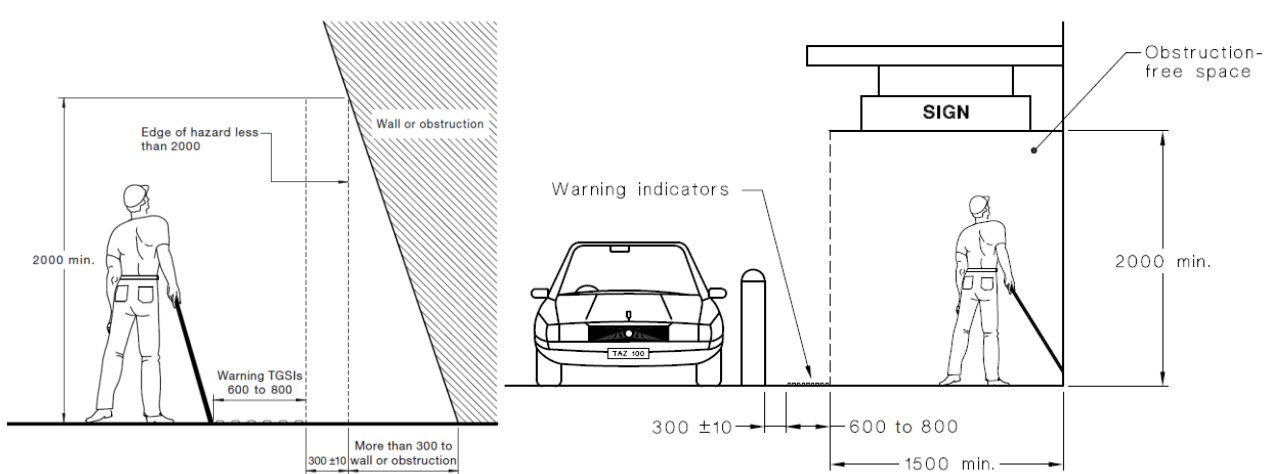

Part D4 – Access for People with Disabilities			
Clause	Description	Status	Comments
			<p>If a car space is to be designated as accessible, the entire shared zone should be provided in accordance with AS2890.6.</p> <p>Bollards</p> <p>Shared zones are to be provided with a bollard 800mm ±50mm from the front of the space and equidistant from either side of the space.</p> <p>Note: the accessible car parking space must be designated as required by this Clause. The shared zone must be provided with a bollard in accordance with AS2890.6.</p> <p>NOTE: A level surface includes surfaces with a gradient of up to 1:40.</p>

Part D4 – Access for People with Disabilities			
Clause	Description	Status	Comments
<p>Each dedicated space shall be identified by means of a white symbol of access in accordance with AS 1428.1 between 800 mm and 1000 mm high placed on a blue rectangle with no side more than 1200 mm, placed as a pavement marking in the centre of the space between 500 mm and 600 mm from its entry point as illustrated.</p>			
D4D7	Signage	CRA	<p>In a building required to be accessible –</p> <p>Braille and tactile signage complying with Specification 15 and incorporating the international symbol of access or deafness, as appropriate, in accordance with AS1428.1 must identify each –</p> <ul style="list-style-type: none"> - Sanitary facility, - Ambulant toilet facility, - Any required accessible carparking space, - Where needed, directional signage to any Carparking space, sanitary facility, or accessible adult change facility. - At Each 'Exit' and which 'Level' an occupant is at also needs to be in braille. <p>Where a bank of sanitary facilities is not provided with an accessible unisex sanitary facility, directional signage incorporating the international symbol of access in accordance with AS 1428.1 must be placed at the location of the sanitary facilities that are not accessible, to direct a person to the location of the nearest accessible unisex sanitary facility.</p> <p>Design verification to be provided prior to the issue of the Construction Certificate.</p>
 <p>The diagram illustrates several accessibility signs. On the left, a sign with a wheelchair symbol and a left-pointing arrow is labeled 'Direction Identification'. Below it is a 'Toilet' sign with a wheelchair symbol and Braille. To the right are signs for 'Ambulant toilet Male' and 'Ambulant toilet Female', each with a person on crutches icon and Braille. Further right is a 'Toilet RH' sign with icons for a man, a woman, and a wheelchair, and Braille. Next is an 'Accessible Entrance' sign with a wheelchair symbol and Braille. On the far right is a sign with a white ear icon on a blue background, representing deafness.</p>			

Part D4 – Access for People with Disabilities			
Clause	Description	Status	Comments
 <p>The top diagram shows a building entrance with a pedestrian circulation space and a car on a carriageway. It includes labels for 'Building line', 'Building entrance', 'Pedestrian circulation space', 'Warning indicators', 'Edge of carriageway at grade', and 'Carriageway'. Dimensions include 600 to 800 for the pedestrian space and 300 ±10 for the carriageway edge. The bottom diagram shows a staircase with a 'Hazard zone' and 'Edge of hazard'. It includes labels for 'Warning TGSIs', 'Edge of hazard', 'Hazard zone', and 'Edge of hazard'. Dimensions include 600 to 800 for the warning TGSIs, 300 ±10 for the hazard zone, and 2000 or less for the hazard zone height.</p>			
 <p>The left diagram shows a person with a cane standing near a 'Wall or obstruction'. It includes labels for 'Edge of hazard less than 2000', 'Warning TGSIs 600 to 800', and 'More than 300 to wall or obstruction'. Dimensions include 2000 min. for the person's height and 300 ±10 for the distance to the wall. The right diagram shows a car and a person with a cane near a 'SIGN'. It includes labels for 'Warning indicators', 'SIGN', 'Obstruction-free space', and '2000 min.'. Dimensions include 300 ±10 for the car's width, 600 to 800 for the sign's width, and 1500 min. for the obstruction-free space.</p>			
D4D8	Hearing Augmentation	N / A	
D4D9	Tactile Indicators	CRA	<p>For a building required to be accessible, tactile ground surface indicators must be provided to warn people who are blind or have a vision impairment in accordance with this clause. I.e.:</p> <ul style="list-style-type: none"> - A stairway, other than a fire-isolated stairway, - An escalator, - A passenger conveyor or moving walk, - A ramp other than a fire-isolated ramp, step ramp, kerb ramp or swimming pool ramp, - In the absence of a suitable barrier an overhead obstruction less than 2m above floor level, other than a doorway. <p>Tactile ground surface indicators required by (a) must comply with sections 1 and 2 of AS/NZS 1428.4.1.</p>

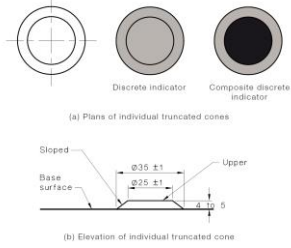
Part D4 – Access for People with Disabilities			
Clause	Description	Status	Comments
<p>There are three (3) distinct types of TGSIs, these each need to be assessed as to the most appropriate based on the surface it is to be applied and lighting conditions. AS1428.4.1 – 2009 clearly provides installation requirements.</p> <div style="display: flex; justify-content: space-around; align-items: flex-end;"> <div style="text-align: center;">  <p>30% contrast to surface</p> </div> <div style="text-align: center;">  <p>45% Contrast to Surface</p> </div> <div style="text-align: center;">  <p>60% Contrast to Surface</p> </div> <div style="text-align: center;">  </div> </div>			
D4D10	Wheelchair Seating Spaces in Class 9b Assembly Buildings	N / A	
D4D11	Swimming Pools	N / A	
D4D12	Ramps	Noted	<p>On an accessway –</p> <p>(a) A series of connected ramps must not have a combined vertical rise of more than 3.6m; and</p> <p>(b) A landing for a step ramp must not overlap a landing for another step ramp or ramp.</p>
D4D13	Glazing on an Accessway	CRA	<p>On an accessway, where there is no chair rail, handrail or transom, all frameless or fully glazed doors, sidelights, and any glazing capable of being mistaken for a doorway or opening, must be clearly marked in accordance with AS 1428.1.</p> <p>Design verification to be provided prior to the issue of the Construction Certificate.</p>

SECTION E – SERVICES AND EQUIPMENT

Part E1 – Fire Fighting Equipment			
Clause	Description	Status	Comments
E1D1	Deemed-to-Satisfy Provisions	-	-
E1D2	Fire Hydrants	CRA	<p>Fire Hydrant Coverage is required throughout the whole building in accordance with AS 2419.1.</p> <p>Location of fire hydrant booster system and pump room (if required) to be provided prior to the issue of the Construction Certificate.</p> <p>Final plans and a design certificate from a qualified hydraulic engineer prior to the issue of a Construction Certificate.</p> <p><i>Please note: If variations from AS2419.1 are required, a Clause 188 approval may be required to be submitted to the NSW Fire Brigade for approval, please allocate time for this process if required.</i></p>
<p>AS2419.1:2021</p> <p>3.5.3 Location</p> <p>3.5.3.1 General</p> <p>External fire hydrants shall be installed as follows:</p> <p>(a) Each external fire hydrant shall be located in a position that provides pedestrian access to the building.</p> <p>(b) Each external fire hydrant shall be located in a position —</p> <ul style="list-style-type: none"> (i). not less than 10 m from the building or fire compartment it is protecting, unless the fire hydrant is protected in accordance with Clause 3.5.5; (ii). not less than 10 m from any high voltage 1main electrical distribution equipment such as transformers and distribution boards; (iii). not less than 10m from any Electric Vehicle Charging Station regardless of voltage unless protected by a wall or other construction having an FRL as defined in Clause 3.5.5.2; (iv). not less than 10 m from a stored quantity of dangerous goods (e.g. LPG, petroleum, propane); (v). not less than 10 m from external combustible storage (e.g. palletized combustible storage items); and (vi). not less than 3 m from the vent terminal of any gas assembly or gas measurement system. <p>NOTE For gas assembly and gas measurement systems, refer to AS/NZS 5601.1.</p> <p>(c) An external fire hydrant shall have an area extending 500mm each side of the fire hydrant hand wheel and 1m in front of the fire hydrant that is free from obstruction.</p> <p>(d) Where a fire hydrant is installed in a car park, or in an area where vehicles manoeuvre or park and the vehicles are able to come not more than 1m from the fire hydrant, bollards shall be provided to protect the fire hydrant and allow for the connection and laying of fire hose.</p> <p>3.5.5 Protection of fire hydrants</p> <p>3.5.5.1 Sprinkler-protected buildings</p>			



Part E1 – Fire Fighting Equipment			
Clause	Description	Status	Comments
	<p>The requirements of Clause 3.5.5.2 do not apply to external fire hydrants located not more than 10m from the building, provided the building is sprinkler-protected by a sprinkler system or a combination of sprinkler systems conforming to AS 2118.1, AS 2118.4, AS 2188.6, FPAA101D or FPAA101H.</p> <p>3.5.5.1 Sprinkler-protected buildings</p> <p>Where external fire hydrants are located not more than 10m from a non-sprinkler-protected building, that shall be protected —</p> <p>(a) if located within or affixed to the external wall of a building by walls, floors and/or ceilings, as applicable, that —</p> <ul style="list-style-type: none">(i). have an FRL not less than 90/90/90;(ii). extend for a distance of not less than 2m each side of the centre-line of the fire hydrant riser; and(iii). extend to a height not less than 3m above ground level. <p>(b) if located not more than 3.5m from the external wall and remote from the building, by either —</p> <ul style="list-style-type: none">(i). the external wall of the building that confirms to Item (a); or(ii). a freestanding wall or similar construction that —<ul style="list-style-type: none">(A) has an FRL not less than 90/90/90;(B) extends not less than 2m each side of the centre-line of the fire hydrant riser;(C) extends to a height not less than 3m above ground level; and(D) is located immediately behind the fire hydrant and between the building and the fire hydrant. <p>(c) if located not less than 3.5m but not more than 10m from the external wall of the building, by a freestanding wall or similar construction that —</p> <ul style="list-style-type: none">(i). has an FRL not less than 90/90/90;(ii). extends for a distance of not less than 1m each side of the centre-line of the fire hydrant valve outlet;(iii). extends for a height of not less than 2m above ground level; and(iv). is located immediately behind the fire hydrant and between the building and the fire hydrant.		
	<p>6.11 Pump room of enclosure</p> <p>6.11.1 General</p> <p>Pumpsets and associated equipment shall be installed within a waterproof room or enclosure that —</p> <p>(i) only contains firefighting pumpsets and associated equipment;</p> <p>(ii) is secured to prevent the entry of unauthorized persons;</p> <p>(iii) is ventilated with fresh air to maintain the aspiration and cooling of pump drivers for the required duration of pump operation;</p> <p>(iv) is heated and insulated, where necessary, to prevent freezing and condensation from forming;</p> <p>(v) is identified by —</p> <ul style="list-style-type: none">(i). a fade-and weather-resistant sign, permanently affixed to the pumproom door, stating in capital letters not less than 50mm high, in a colour contrasting with the background, FIRE PUMP ROOM; and(ii). a red strobe light, activated by the operation of the fixed on-site pumps, located outside the building, adjacent to the door providing access to the pump room; <p>(vi) is construction with an internal clearance of not less than 2.1m; and</p> <p>(vii) is sixed to allow for pump maintenance and replacement to occur.</p>		

Part E1 – Fire Fighting Equipment			
Clause	Description	Status	Comments
6.11.2 Internal pump rooms			
Where the pump room is located within the protected building, the following shall apply:			
(a) Where a building is protected throughout by a sprinkler system conforming to AS 2118.1, AS 2118.4, AS 2118.6 or FPAA101H, the requirements of Item (b) need not apply.			
(b) A pump room shall have the following:			
(i). A fire resisting construction including walls and , where applicable, floor and roof that have an FRL not less than that required for a firewall for the building classification and type of construction applied to the building.			
(ii). Doorways protected with self-closing doors that have an FRL not less than that required for a fire wall required in Item (i), except that the door shall have an insulation level of not less than 30 min.			
(iii). Construction joints, service penetrations and other openings protected in a manner that maintains the FRL for the wall, roof or floor as required by Item (i).			
NOTE 1 Refer to the NCC for requirements related to the FRL of a fire wall, roof, or floor for different building classifications.			
NOTE 2 Refer to the NCC for requirements relating to construction joints, service penetrations and other openings in a fire wall, roof, or floor.			
(c) The pumproom shall have a door leading directly to —			
(i). road or open space;			
(ii). an airlock or smoke lobby that leads to —			
(A) a fire-isolated passageway or stair, leading to road or open space; and			
(B) a fire-isolated passageway or stair, pressurized in accordance with AS/NZS 1668.1, leading to road or open space.			
NOTE 3 Refer to the NCC for more information on the construction of an airlock or smoke lobby.			
(d) Where a compression ignition engine pumpset is installed —			
(i). the exhaust system for the pumpset shall discharge outside the building or to a mechanical exhaust system capable of safely discharging the pump exhaust gases;			
(ii). the discharge outlet from the exhaust system shall be not less than 2.7m above a path of travel or road.			
NOTE 4 The exhaust gases from the exhaust system discharge outlet should discharge clear of any ventilation, door or window openings within the building for the health and safety of persons within the building and at a height and orientation so as not to affect any person in the vicinity of the discharge outlet.			
6.11.2 External pump rooms or enclosures			
Where a pump room or enclosure is located externally to the protected building the following apply:			
(a) Where a building is protected throughout by a sprinkler system conforming to AS 2118.1, AS 2118.4, AS 2118.6 or FPAA101H, or the pumproom is located more than 6m from the protected building, the requirements of Item (b) do not have to be applied.			
(b) Any parts of the pump room or enclosure located not more than 6m from the protected building shall have the following:			
(i). A fire resisting construction including walls and, where applicable, floor and roof that has an FRL not less than that required for a firewall for the building classification and Type of Construction applied to the building.			
(ii). Doorways protected with self-closing doors having an FRL not less than that required for a fire wall as required in Item (i), except that the door shall have an insulation level of at least 30 min.			
(iii). Construction joints, service penetrations, service penetrations for ventilation that face the protected building and other openings, protected in a manner that maintains the FRL for the wall, roof or floor as required by Item (i).			

Part E1 – Fire Fighting Equipment

Clause	Description	Status	Comments
--------	-------------	--------	----------

NOTE 1 Refer to the NCC for requirements relating to the FRL of a fire wall, roof, or floor for different building classifications.

NOTE 2 Refer to the NCC for requirements relating to construction joints, service penetrations and other openings in a fire wall, roof, or floor.

- (c) The pumproom shall be located not more than 20m from a hardstand.
- (d) The pumproom shall be located not less than 10 m from —
 - (i). any high voltage electrical distribution equipment, such as transformers and distribution boards;
 - (ii). any stored dangerous goods (e.g. LPG, petroleum, propane); and
 - (iii). any external combustible storage (e.g. palleted combustible storage items).
- (e) Where a compression ignition engine pumpset is installed –
 - (i). the exhaust system from the pumpset shall discharge outside the building or to a mechanical exhaust system that is capable of safely discharging the pump exhaust gases; and
 - (ii). the discharge outlet from the exhaust shall be located not less than 2.7 m above a path of travel or road.

NOTE 3 The exhaust gases from the exhaust system discharge outlet should discharge clear of any ventilation, door or window openings within the building for the health and safety of persons within the building and at a height and orientation so as not to affect any person in the vicinity of the discharge outlet.

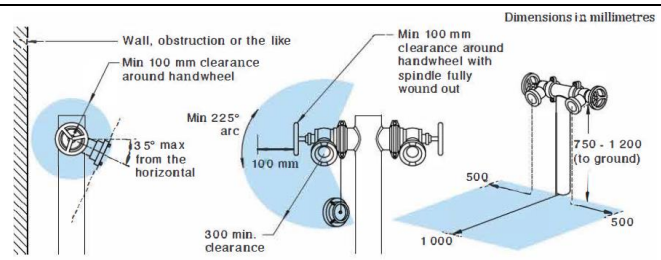

Figure H.3(A) — External fire hydrant clearances

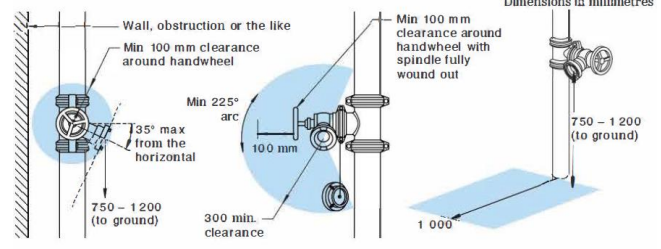

Figure H.3(B) — Internal fire hydrant clearances

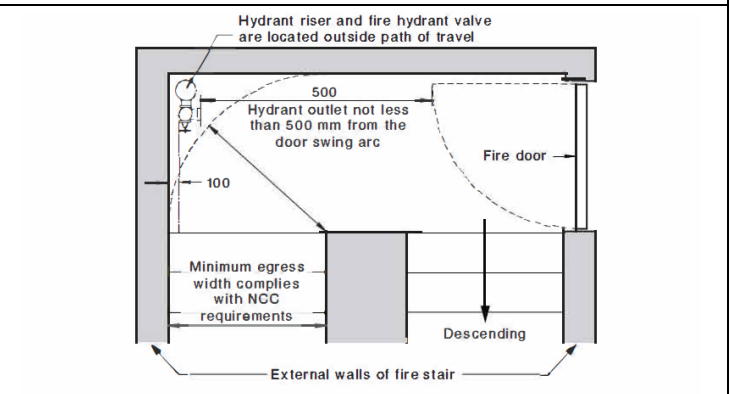
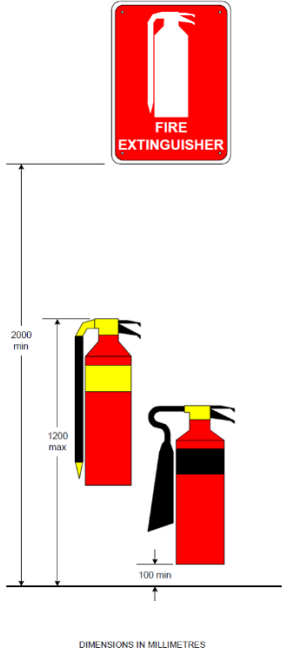

Figure H.3(C) — Internal fire hydrant clearances required within a fire isolated stair



Part E1 – Fire Fighting Equipment			
Clause	Description	Status	Comments
	<p>Fire hydrant coverage from a fire brigade pumping appliance may only provide coverage up to the lowest four storeys included in the calculation of the rise in storeys, provided all parts of all storeys are covered</p> <p>Rise in storeys = 4</p> <p>Fire brigade pumping appliance supplied from a street or feed fire hydrant</p> <p>Designated hardstand. Fire brigade pumping appliance located not less than 10 m from the building</p> <p>Fire hydrant coverage from a fire brigade pumping appliance may only provide coverage to one level below the lowest storey used in the calculation of the rise in storeys provided all portions of the building are covered (in this case basement level 1)</p> <p>Figure H.6.1.2(A) — Coverage from a fire brigade pumping appliance</p>		
	<p>Fire hydrant coverage from an external attack fire hydrant may only provide coverage up to the lowest four storeys included in the calculation of the rise in storeys, provided all parts of all storeys are covered</p> <p>Rise in storeys = 4</p> <p>External attack fire hydrant</p> <p>Fire brigade booster assembly</p> <p>Designated hardstand. Fire brigade pumping appliance located not more than 20 m from the booster</p> <p>Fire hydrant coverage from an external attack fire hydrant may only provide coverage to one level below the lowest storey used in the calculation of the rise in storeys provided all portions of the building are covered (in this case basement level 1)</p> <p>Figure H.6.1.3 — External attack fire hydrant coverage</p>		
	<p>Internal fire hydrants provide fire hydrant coverage to those storeys not protected by external fire hydrants</p> <p>External fire hydrants only provide fire hydrant coverage to the lowest storey used in the calculation of the rise in storeys and the storey below this storey (in this case the ground floor/mezzanine level 1 and basement level 1)</p> <p>Fire compartments complying with the NCC</p> <p>External attack fire hydrant</p> <p>Fire brigade booster assembly</p> <p>Designated hardstand. Fire brigade pumping appliance located not more than 20 m from the booster</p> <p>Figure H.6.1.4 — External fire hydrant coverage</p>		
	<p>Fire hydrant coverage provided to the lowest storey used in the calculation of rise in storeys (typically the ground floor), a mezzanine or storey located within the fire compartment that contains this storey</p> <p>Maximum 70 m fire hydrant coverage from fire brigade pumping appliance supplied by the feed fire hydrants of the fire brigade booster assembly</p> <p>Fire hydrant coverage provided to the storey immediately below the lowest storey used in the calculation of rise in storeys</p> <p>Figure H.6.4 — Feed fire hydrant coverage from a fire brigade booster assembly</p>		
E1D3	Fire hose reels	CRA	<p>Fire hose reels coverage is required throughout the building if a hydrant is located within the building.</p> <p>Where fire hose reels are located within the building, they are to be within 4m of an exit, additional hose reels may be provided for coverage purposes however are to be located in a path of travel to an exit.</p> <p>Fire hose reels are to be installed accordance with AS2441.</p> <p>Final plans and a design certificate from a qualified hydraulic engineer prior to the issue of a Construction Certificate.</p>

Part E1 – Fire Fighting Equipment			
Clause	Description	Status	Comments
E1D10	Where sprinklers are required: Class 9a health-care building used as a residential care building and Class 9c buildings	N / A	
E1D11	Where sprinklers are required: Class 9b buildings	PS	<p>(1) In a Class 9b building, other than an early childhood centre, see Part I1.</p> <p>(2) In a building containing a Class 9b early childhood centre, sprinklers are required throughout the whole building, including any part of another class.</p> <p>E1D11(2) does not apply to a Class 9b early childhood centre wholly within a storey that provides direct egress to a road or open space; or with a rise in storeys of not more than 2, where the Class 9b early childhood centre is the only use in the building.</p> <p>Compliance can be achieved via undertaking a fire engineering performance solution prior to issue of the Construction Certificate.</p>
E1D12	Where sprinklers are required: additional requirements	N / A	
E1D13	Where sprinklers are required: occupancies of excessive hazard	N / A	
E1D14	Portable fire extinguishers	CRA	<p>Portable fire extinguishers are required to be provided in accordance with Clause E1D14 of the BCA and AS 2444.</p> <p>Details verifying compliance must be included on the architectural plans prior to the issue of the Construction Certificate.</p>

Part E1 – Fire Fighting Equipment			
Clause	Description	Status	Comments
AS 2444—2001	 <p>DIMENSIONS IN MILLIMETRES</p> <p>FIGURE 3.2 MOUNTING HEIGHTS FOR PORTABLE FIRE EXTINGUISHERS AND LOCATION SIGNS</p>	10	<p>Signs are to be installed clearly over or directly adjacent to Portable fire extinguishers.</p> <ul style="list-style-type: none"> – Each extinguisher shall be located in a conspicuous and readily accessible position. Extinguishers shall not be located in positions where access could present a hazard to the potential user. Where practicable, extinguishers shall be located along normal paths of travel and near exits. (Max 15m from each other etc) – Extinguishers Signs must be shown and shall be mounted not less than 2.0 m above floor level, or at a height that makes them most apparent to a person of average height and visual acuity approaching the extinguisher location. <p>In addition to the location sign referred to in Clause 3.3 of AS2444, the cabinet or enclosure shall be marked with the words 'FIRE EXTINGUISHER' in letters at least 32 mm high in a colour contrasting with the background unless the door has not less than 50% of its surface area fabricated from transparent material that permits visual identification of the cabinet's contents. Signs are to be installed clearly over or directly adjacent to Portable fire extinguishers.</p> <ul style="list-style-type: none"> – Each extinguisher shall be located in a conspicuous and readily accessible position. Extinguishers shall not be located in positions where access could present a hazard to the potential user. Where practicable, extinguishers shall be located along normal paths of travel and near exits. (Max 15m from each other etc) – Extinguishers Signs must be shown and shall be mounted not less than 2.0 m above floor level, or at a height that makes them most apparent to a person of average height and visual acuity approaching the extinguisher location.
E1D15	Fire control centres	Noted	
E1D16	Fire precautions during construction	CRA	<p>During construction, not less than one fire extinguisher to suit Class A, B and C fires is required for each storey, and is required to be located adjacent to each exit.</p> <p>After the building has reached an effective height of 12m:</p> <ul style="list-style-type: none"> • The required fire hydrants and fire hose reels must be operational in at least ever storey that is covered by the roof or the floor structure above, except the two (2) upper most storeys; and • Any required booster connection must be installed. <p>Details verifying compliance must be included on the architectural plans prior to the issue of the Construction Certificate.</p>
E1D17	Provision for special hazards	N / A	

General Fire Service Signage	
<p>FIRE HOSE REEL</p> <p>FIRE HYDRANT BOOSTER</p> <p>FIRE EXTINGUISHER</p> <p>SPRINKLER STOP VALVE INSIDE</p> <p>FIRE PANEL</p>	<p>FIRE HYDRANT PUMP – DO NOT SWITCH OFF</p> <p>SPRINKLER BOOSTER CONNECTION</p> <p>FIRE CONTROL ROOM</p>

Part E2 – Smoke Hazard Management			
Clause	Description	Status	Comments
E2D1	Deemed-to-Satisfy Provisions	-	
E2D2	Application of Part	Noted	Part is not applicable to open-deck car parks, open spectator stands or Class 8 electricity network substations with a floor area not more than 200m ² , located within a multi-classified building.
E2D3	General requirements	CRA	The building must be provided with an automatic smoke detection and alarm system, and smoke detectors complying with Specification 20 and a Building Occupant Warning System (BOWS). Details and a design certificate will be required by a qualified electrical engineer prior to the issue of a Construction Certificate.
E2D4	Fire-isolated exits	N / A	
E2D5	Buildings more than 25 m in effective height: Class 2 and 3 buildings and Class 4 part of a building	N / A	
E2D6	Buildings more than 25 m in effective height: Class 5, 6, 7b, 8 and 9b buildings	N / A	
E2D7	Buildings more than 25 m in effective height: Class 9a buildings	N / A	

Part E2 – Smoke Hazard Management			
Clause	Description	Status	Comments
E2D8	Buildings not more than 25 m in effective height: Class 2 and 3 buildings and Class 4 part of a building	N / A	
E2D9	Buildings not more than 25 m in effective height: Class 5, 6, 7b, 8 and 9b buildings	CRA	<p>An air handling system which does not form part of a smoke management system in accordance with Clauses E2D4 – E2D20 and which recycles air from one compartment to another fire compartment or operates in a manner that may unduly contribute to the spread of smoke from one fire compartment to another fire compartment must-</p> <ul style="list-style-type: none"> • Be designed and installed to operate as a smoke control system in accordance with AS/NZS 1668.1; or • Incorporate smoke dampers where the air-handling ducts penetrate any elements separating the fire compartments served; and • Be arranged such that the air handling system is shut down and the smoke dampers are activated to close automatically by smoke detectors complying with Clause 4.10 of AS/NZS 1668. <p>Details and a design certificate will be required by a qualified electrical engineer prior to the issue of a Construction Certificate.</p>
E2D10	Buildings not more than 25 m in effective height: large isolated buildings subject to C3D4	N / A	
E2D11	Buildings not more than 25 m in effective height: Class 9a and 9c buildings	N / A	
E2D12	Class 7a buildings	CRA	<p>The carpark is to be provided with a mechanical ventilation system in accordance AS 1668.2 and must comply with Clause 5.5 of AS 1668.1 except that:</p> <ul style="list-style-type: none"> • The carpark is to be provided with fans with metal blades suitable for operation at normal temperature and electrical power and control cabling need not be fire rated. Upon activation of the BOWS, the fans are to run at full speed. <p>Details and a design certificate will be required by a qualified mechanical engineer prior to the issue of a Construction Certificate.</p>
E2D13	Basements (other than Class 7a buildings)	N / A	

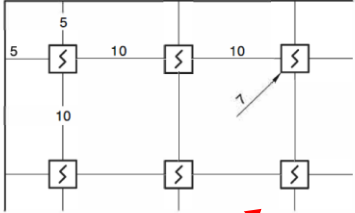
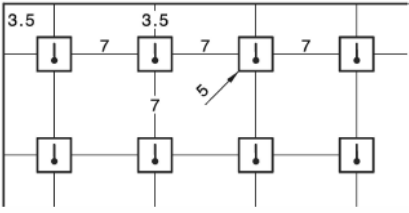
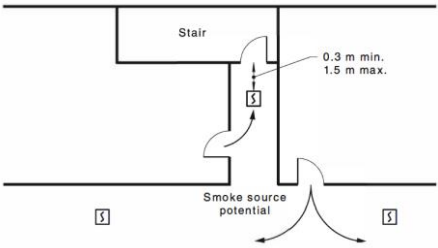
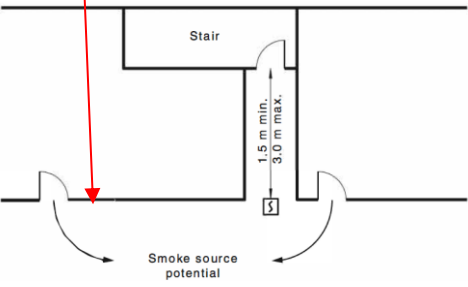

Part E2 – Smoke Hazard Management			
Clause	Description	Status	Comments
E2D14	Class 6 buildings – in fire compartments more than 2000m ² : Class 6 building (not containing an enclosed common walkway or mall serving more than one Class 6 sole-occupancy unit)	N / A	
E2D15	Class 6 buildings – in fire compartments more than 2000m ² : Class 6 building (containing an enclosed common walkway or mall serving more than one Class 6 sole-occupancy unit)	N / A	
E2D16	Class 9b – assembly buildings: nightclubs, discotheques and the like	N / A	
E2D17	Class 9b – assembly buildings: exhibition halls	N / A	
E2D18	Class 9b – assembly buildings: theatres and public halls	N / A	
E2D19	Class 9b – assembly buildings: theatres and public halls (not listed in E2D18) including lecture theatres and cinema/auditorium complexes	N / A	
E2D20	Class 9b assembly buildings: other assembly buildings (not listed in E2D16 to E2D19)	N / A	

Part E2 – Smoke Hazard Management			
Clause	Description	Status	Comments
	 <p>DIMENSIONS IN MILLIMETRES</p> <p>FIGURE 5.1.1(A) MAXIMUM SMOKE DETECTOR OR SMOKE ALARM SPACING LEVEL SURFACES</p>		 <p>I.e.: Heat Detectors – AS1670.1</p>
	 <p>Stair</p> <p>0.3 m min. 1.5 m max.</p> <p>Smoke source potential</p>		 <p>Stair</p> <p>1.5 m min. 3.0 m max.</p> <p>Smoke source potential</p> <p>I.e.: Smoke Detectors – AS1668.1 (M/V Shutdown etc.)</p>
E2D21	Provision for special hazards	N / A	

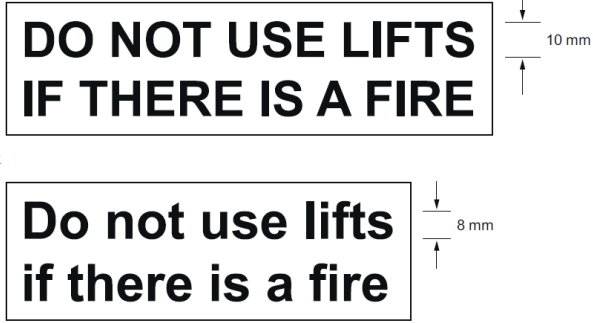
Part E3 – Lift Installations			
Clause	Description	Status	Comments
E3D1	Deemed-to-Satisfy Provisions	-	-
E3D2	Lift Installations	CRA	An electric passenger lift installation and an electrohydraulic passenger lift installation must comply with Specification 24. Final design to be confirmed at the Construction Certificate stage.
E3D3	Stretcher facility in lifts	Noted	A stretcher facility in lifts is not required to be installed in a building with an effective height of less than 12m. Minimum cart size should be 1400mm X 1100mm as per the requirements of Clause E3D8.
E3D4	Warning against use of lifts in fire	Noted	A warning sign is to be displayed where it can be readily seen near every call button of the passenger lift. The warning sign is to comply with the details and dimensions set out in Figure E3D4 of the BCA. Figure E3D4: Warning sign for passenger lifts 
E3D5	Emergency lifts	N / A	
E3D6	Landings	CRA	Access and egress to and from the lift well landings are to comply with Parts D2, D3 and D4 of the BCA. Ensure all lift landings achieve an unobstructed width of 1540mm x 2070mm as required by AS 1428.1-2009. <i>Refer to Clause D4D4 of this report for further detail.</i> To be confirmed with details provided at Construction Certificate stage or design statement.
E3D7	Passenger lift types and their limitations	CRA	In an accessible building, every passenger lift must be one of the following lift types, subject to the limitations (if any) of each lift type as outlined in Clause E3D7: <ul style="list-style-type: none"> • Electric passenger lifts, electrohydraulic passenger lifts or inclined lifts; • Stairway platform lifts; • A low-rise platform lift; • A low-rise, low-speed constant pressure lift; A small-sized, low-speed automatic lift.



Part E3 – Lift Installations			
Clause	Description	Status	Comments
E3D8	Accessible features required for passenger lifts	CRA	<p>A passenger lift within the building other than a stairway platform lift is to comply with several features from AS1735.12, including:</p> <ul style="list-style-type: none">- Passenger protection system for a lift with power-operated doors;- 900mm minimum clearance through lift doors;- Lift landing doors at upper landings;- Lift car and landing control buttons;- Handrail to be provided within the cart;- Braille and location of Control buttons;- Lighting for an enclosed lift car;- Audio and Visual indicators for a lift serving more than 2 levels; and- Emergency hands-free communication. <p>Lift floor dimensions of not less than 1400mm x 1100mm to be provided as the lift is deemed to travel less than 12m.</p> <p>Details verifying compliance must be included on the architectural plans prior to the issue of the Construction Certificate.</p>
E3D9	Fire service controls	Noted	
E3D10	Residential care buildings	N / A	
E3D11	Fire service recall control switch	Noted	
E3D12	Lift car fire service drive control switch	Noted	

Part E4 – Visibility in an Emergency, Exit Signs and Warning Systems			
Clause	Description	Status	Comments
E4D1	-	-	No provisions
E4D2	Emergency lighting requirements	CRA	Emergency lighting is to be provided throughout the building in accordance with Clause E4D2 of the BCA. Drawings a design certificate will be required by a suitably qualified electrical engineer prior to the issue of a Construction Certificate.
E4D3	Measurement of distance	Noted	
E4D4	Design and operation of emergency lighting	CRA	Emergency lighting shall be provided throughout the building in accordance with the requirements of Clause E4D4 of the BCA and AS 2293.1. Details and a design certificate will be required by a suitably qualified electrical engineer prior to the issue of a Construction Certificate.
E4D5	Exit signs	CRA	Exit signs are to be provided in accordance with Clause E4D5 of the BCA.
	 <p>(a) Straight on from here (Refer to paragraph 53.3)</p> <p>(b) Left from here</p> <p>(c) Right from here</p>		<p>Exit signs must be clearly visible to person approaching the exit and must be installed on, above or adjacent to;</p> <ol style="list-style-type: none"> 1. A door providing direct egress from a storey to a stairway, passageway or ramp serving as a required exit. 2. A door from an enclosed stairway, passageway or ramp at every level of discharge to a road or open space. 3. A door serving as or forming part of a required exit in a storey required to be provided with emergency lighting. <p>A test switch is to be installed for each storey.</p> <p>Where and if requirements are altered under this proposal, details and a design certificate will be required by a suitably qualified electrical engineer prior to the issue of a Construction Certificate.</p>
E4D6	Direction signs	CRA	Where an exit is not readily apparent then exit signs with directional arrows must be installed in appropriate positions in corridors, hallways, lobbies and the like indicating the direction to a required exit in accordance with Clause E4D6 of the BCA. Where and if requirements are altered under this proposal, details and a design certificate will be required by a suitably qualified electrical engineer prior to the issue of a Construction Certificate.
E4D7	Class 2 and 3 buildings and Class 4 parts: exemptions	Noted	

Part E4 – Visibility in an Emergency, Exit Signs and Warning Systems			
Clause	Description	Status	Comments
E4D8	Design and operation of exit signs	CRA	Exit signs are to operate in accordance with AS 2293.1 or for a photo luminescent exit sign, Specification E4D8 and be clearly visible at all times while the building is occupied. Where and if requirements are altered under this proposal, details and a design certificate will be required by a suitably qualified electrical engineer prior to the issue of a Construction Certificate.
E4D9	Emergency warning and intercom systems	N / A	

SECTION F – HEALTH AND AMENITY

Part F1 – Surface water management, rising damp and external waterproofing

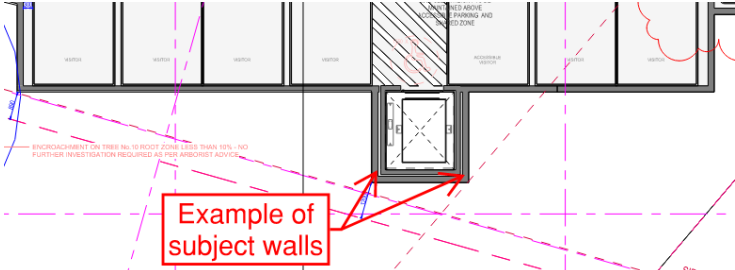
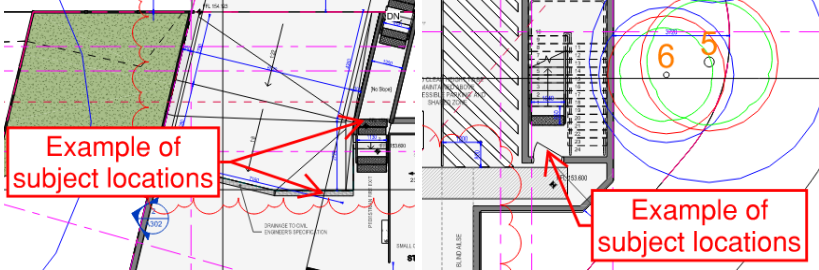
Clause	Description	Status	Comments
F1D1	Deemed-to-Satisfy Provisions	Noted	Where a Deemed-to-Satisfy Solution is proposed, Performance Requirements F1P1 to F1P4 are satisfied by complying with F1D2 to F1D8.
F1D2	Application of Part	Noted	<p>(1) F1D4 and F1D5 do not apply to a roof with a covering complying with F3D2(a) to (d).</p> <p>(2) F1D3 to F1D5 do not apply to a balcony, podium or similar horizontal surface part of a building-</p> <p style="margin-left: 20px;">(a) where the flooring is of timber decking or other perforated flooring; or</p> <p style="margin-left: 20px;">(b) which is located directly above ground.</p>
F1D3	Stormwater drainage	CRA	<p>Stormwater drainage design shall be in accordance with AS/NZS 3500.3.</p> <p>Lift Wet Walls</p> <p>Wet walls appear to be provided within the lift shaft. Lift designer and manufacturer to confirm compliance prior to issue of the Construction Certificate.</p>  <p>Hobs & Strip Drains</p> <p>Hobs and strip drains to be provided to the external openings located along the open balconies/corridors, entry within the basement, and open spaces or the like.</p> 

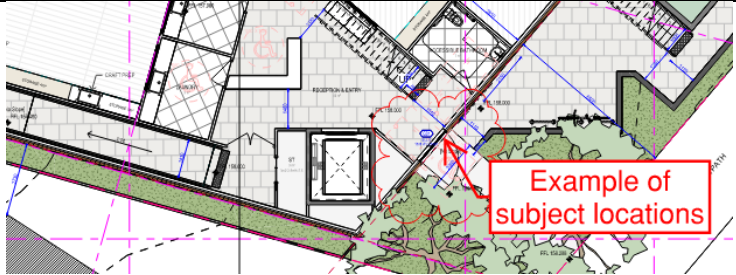
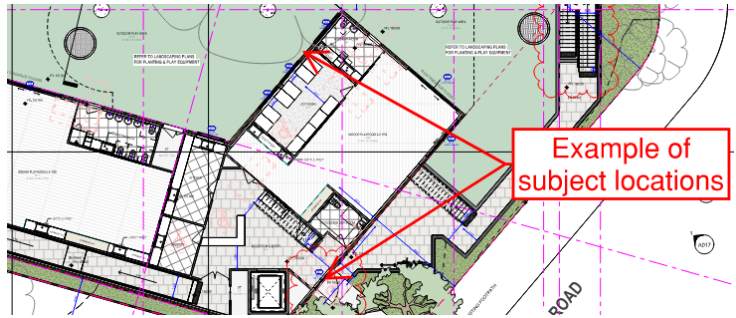
Part F1 – Surface water management, rising damp and external waterproofing			
Clause	Description	Status	Comments
			 <p>Example of subject locations</p> <p>Details and a design certificate will be required by a suitably qualified hydraulic and/or civil engineer prior to the issue of a Construction Certificate.</p>
F1D4	Exposed joints	CRA	<p>Exposed joints in the drainage surface on a roof balcony, podium or similar horizontal surface part a building must be protected in accordance with Section 2.9 of AS 46542 and not be located beneath or run through a planter box, water feature or similar part of the building.</p> <p>Details and a design certificate to be provided prior to the issue of a Construction Certificate.</p>
F1D5	External waterproofing membranes	CRA	<p>A roof, balcony, podium or similar horizontal surface part of a building must be provided with a waterproofing membrane consisting of materials complying with AS4654.1 and designed and installed in accordance with AS4654.2.</p> <p>Wind speed and N rating are required to calculate the waterproofing termination height and hob sizes.</p>  <p>Example of subject locations</p> <p>Details and a design certificate to be provided prior to the issue of a Construction Certificate.</p>
F1D6	Damp-proofing	N / A	
F1D7	Damp-proofing of floors on the ground	CRA	<p>A vapour barrier in accordance with AS2870 is to be provided beneath the basement floor slab.</p> <p>Details and design certification to be provided prior to the issue of a Construction Certificate.</p>
F1D8	Subfloor ventilation	N / A	

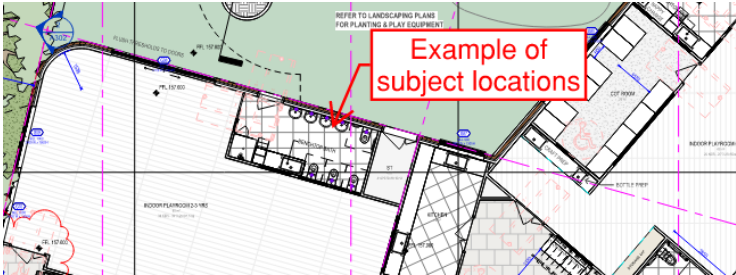

Part F2 – Wet areas and overflow protection			
Clause	Description	Status	Comments
F2D1	Deemed-to-Satisfy Provisions	Noted	Where a Deemed-to-Satisfy Solution is proposed, Performance Requirements F2P1 and F2P2 are satisfied by complying with F2D2 to F2D4.
F2D2	Wet area construction	CRA	<p>Shower enclosure surfaces, floor surfaces in bathrooms, shower rooms, slop hoppers, sink compartments, laundry and sanitary compartments is required to be waterproofed in accordance with AS 3740.</p> <p>In a Class 7 and Class 9 building, building elements in the bathroom or shower room, a slop hopper or sink compartment, a laundry or sanitary compartment must be water resistant or waterproof in accordance with Specification 26 and comply with AS 3740-2010 as if they were in a Class 2 or 3 building or a Class 4 part of a building.</p> <p>Details and design certification to be provided prior to the issue of a Construction Certificate.</p>
F2D3	Rooms containing urinals	CRA	<p>Rooms containing urinals are to comply with Clause F2D3 of the BCA.</p> <p>Where a slab or stall type urinal is installed:</p> <p>The floor surface of the room containing the urinal must be an impervious material and where no step is installed, be graded to the urinal channel for a distance of 1.5m from the urinal channel and the remainder of the floor be graded to a floor waste; and</p> <p>Where a step is installed:</p> <p>The step must have an impervious surface and be graded to the urinal channel and the floor being the step must be graded to a floor waste; and</p> <p>The junction between the floor surface and the urinal channel must be impervious.</p> <p>Where a wall hung urinal is installed:</p> <p>The wall must be surfaced with impervious material extending from the floor not less than 50mm above the top of the urinal and not less than 225mm on each side of the urinal.</p> <p>The floor must be surfaced with impervious material and graded to a floor waste.</p> <p>In a room with timber or steel framed walls and containing a urinal:</p> <p>The wall must be surfaced with an impervious material extending from the floor to not less than 100mm above the floor surface and the junction of the floor surface and the wall surface must be impervious.</p> <p>The newly proposed sanitary compartments are to comply with the following.</p> <p>Details and design certification to be provided prior to the issue of a Construction Certificate.</p>

Part F2 – Wet areas and overflow protection			
Clause	Description	Status	Comments
F2D4	Floor wastes	CRA	<p>Where a floor waste is installed-</p> <p>(a) the minimum continuous fall of a floor plan to the waste must be 1:80; and</p> <p>(b) the maximum continuous fall of a floor plan to the waste must be 1:50.</p> <p>Architectural plans to confirm locations of proposed floor wastes throughout the development including, but not limited to: laundries; bathrooms; showers; balconies; open spaces and the like.</p>  <p>The plans forming part of the Construction Certificate Application must detail compliance with the above.</p>

Part F3 – Roof and wall cladding			
Clause	Description	Status	Comments
F3D1	Deemed-to-Satisfy Provisions	Noted	Where a Deemed-to-Satisfy Solution is proposed, Performance Requirement F3P1 is satisfied by complying with F3D2 to F3D5.
F3D2	Roof coverings	CRA	Roof coverings are to comply with the relevant Australian Standards as per Clause F3D2. Details and design certification to be provided prior to the issue of a Construction Certificate.
F3D3	Sarking	CRA	Sarking type materials used for weatherproofing of roofs and walls must comply with AS/NZS 4200 Parts 1 and 2. Details and design certification to be provided prior to the issue of a Construction Certificate.
F3D4	Glazed assemblies	CRA	Windows, sliding doors with a frame, adjustable louvres, shopfronts and window walls with one piece framing in an external wall must comply with AS 2047 requirements for resistance to water penetration. Details and design certification to be provided prior to the issue of a Construction Certificate.
F3D5	Wall Cladding	CRA	External wall cladding must comply with one of a combination of the following: <ul style="list-style-type: none"> • Masonry, including masonry veneer, unreinforced and reinforced masonry: AS 3700. • Autoclaved aerated concrete: AS 5146.3. • Metal wall cladding: AS 1562.1. Details and design certification to be provided prior to the issue of a Construction Certificate.



Part F4 – Sanitary and Other Facilities			
Clause	Description	Status	Comments
F4D1	Deemed-to-Satisfy Provisions	Noted	-
F4D2	Facilities in residential buildings	N / A	
F4D3	Calculation of number of occupants and fixtures	CRA	<p>Floor area of each room is to be provided for the purpose of calculating occupant numbers within the building.</p> <p>Note: a unisex facility comprises one closet pan, one washbasin and means for the disposal of sanitary towels.</p> <p>Details and design certification to be provided prior to the issue of a Construction Certificate.</p>
F4D4	Facilities in Class 3 to 9 buildings	CRA	<p>Class 9b building used as an early childhood centre must comply with the following:</p> <p>(a) A Class 9b <u>early childhood centre</u> must be provided with—</p> <p>(i) a kitchen or food preparation area with a kitchen sink, separate hand washing facilities, space for a refrigerator and space for cooking facilities, with—</p> <p>(A) the facilities protected by a door or gate with child proof latches to prevent unsupervised access to the facilities by children younger than 5 years old; and</p> <p>(B) the ability to facilitate supervision of children from the facilities if the <u>early childhood centre</u> accommodates children younger than 2 years old; and</p> <p>(ii) one bath, shower or shower-bath; and</p> <p>(iii) if the centre accommodates children younger than 3 years old—</p> <p>(A) a laundry facility comprising a washtub and space in the same room for a washing machine; and</p> <p>(B) a bench type baby bath, which is within 1 m of the nappy change bench; and</p> <p>(C) a nappy changing bench which—</p> <p>(aa) is within 1 m of separate adult hand washing facilities and bench type baby bath; and</p> <p>(bb) must be not less than 0.9 m² in area and at a height of not less than 850 mm, but not more than 900 mm above the finished floor level; and</p> <p>(cc) must have a space not less than 800 mm high, 500 mm wide and 800 mm deep for the storage of steps; and</p> <p>(dd) is positioned to permit a staff member changing a nappy to have visibility of the play area at all times.</p> <p>(b) Class 9b theatres and sporting venues must be provided with one shower for each 10 participants or part thereof.</p> <p>(c) Not less than one washbasin must be provided where closet pans or urinals are provided.</p> <p>Details and design certification to be provided prior to the issue of a Construction Certificate.</p>

Part F4 – Sanitary and Other Facilities

Clause	Description	Status	Comments
--------	-------------	--------	----------

Table F4D4f: Sanitary facilities in Class 9b buildings – schools

User group	Closet pans		Urinals		Washbasins	
	Design occupancy	Number	Design occupancy	Number	Design occupancy	Number
Male employees	1 - 20	1	1 - 10	0	1 - 30	1
	>20	Add 1 per 20	11 - 20	1	>30	Add 1 per 30
	-	-	21 - 45	2	-	-
	-	-	>45	Add 1 per 30	-	-
Female employees	1 - 5	1	N/A	N/A	1 - 30	1
	>5	Add 1 per 15	N/A	N/A	>30	Add 1 per 30
Male students	1 - 25	1	1 - 50	1	1 - 10	1
	26 - 75	2	51 - 100	2	11 - 50	2
	76 - 150	3	>100	Add 1 per 100	51 - 100	3
	151 - 200	4	-	-	>100	Add 1 per 75
	>200	Add 1 per 100	-	-	-	-
Female students	1 - 10	1	N/A	N/A	1 - 10	1
	11 - 25	2	N/A	N/A	11 - 50	2
	26 - 100	Add 1 per 25	N/A	N/A	51 - 100	3
	>100	Add 1 per 50	N/A	N/A	>100	Add 1 per 75

Table F4D4g: Sanitary facilities in Class 9b buildings – early childhood centres

User group	Closet pans		Washbasins	
	Design occupancy	Number	Design occupancy	Number
Children	1 - 30	2	1 - 30	2
	>30	Add 1 per 15	>30	Add 1 per 15

Table Notes

- (1) Urinals are not *required* for a Class 9b *early childhood centre*.
- (2) Facilities for use by children must be—
 - (a) junior pans; and
 - (b) washbasins with a rim height not exceeding 600 mm; and
 - (c) accessible from both indoor and outdoor play areas.

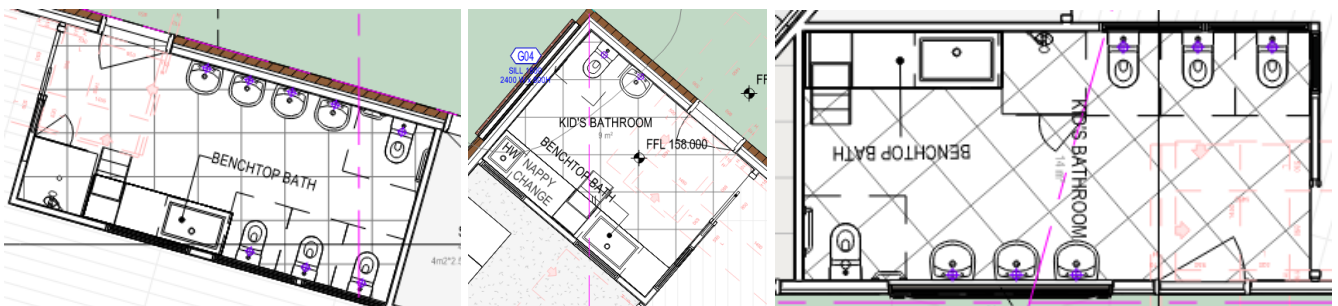

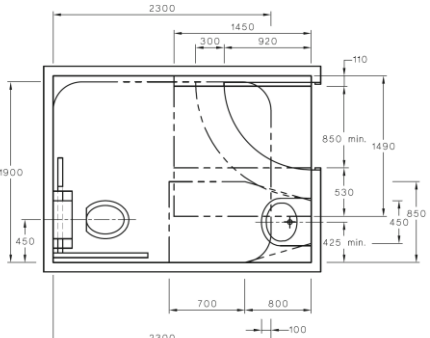
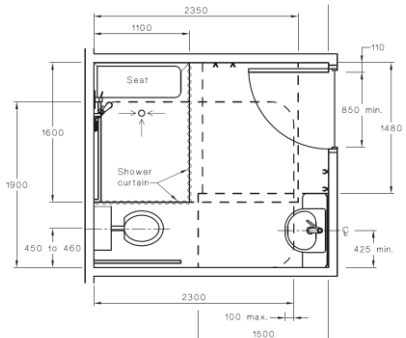
Part F4 – Sanitary and Other Facilities			
Clause	Description	Status	Comments
F4D5	Accessible sanitary facilities	CRA	<p>Accessible unisex sanitary compartments must be provided in accessible parts of the building in accordance with F4D6, and accessible unisex showers must be provided in accordance with F4D7.</p> <p>At each bank of toilets where there is one more or more toilets in addition to an accessible unisex sanitary compartment at that bank of toilets, not less than one sanitary compartment suitable for a person with an ambulant disability for use by males and one sanitary compartment suitable for a person with an ambulant disability for use by females must be provided.</p> <p>Full compliance with AS1428.1:2009 is to be indicated on the Construction Certificate plans.</p> <p>WC detail sheet with all compliance requirements as per AS1428.1-2009 to be provided prior to issue of the Construction Certificate.</p>
F4D6	Accessible unisex sanitary compartments	CRA	<p>Any new toilet bank and where there is more than one bank of toilets, ½ must be accompanied via an <u>Accessible Toilet</u> in accordance with AS1428.1.</p> <p>Full compliance with AS1428.1:2009 is to be indicated on the Construction Certificate Plans.</p>
		<p>Full compliance with AS1428.1:2009 is to be indicated on the Construction Certificate plans or via Design Certificate.</p> <p>Occupants are to be provided with two (2) different types of accessible toilets;</p> <p>1: An accessible <i>toilet</i> compartment (Wheelchairs) i.e.:</p> <ul style="list-style-type: none"> - Ground floor <i>RH Transfer</i> - First Floor <i>LH Transfer</i> etc. <p>2: an ambulant <i>cubicle</i> being a minimum normal toilet cubicle size for easier use (Persons with mobility difficulties) in each and every toilet bank.</p>	
			

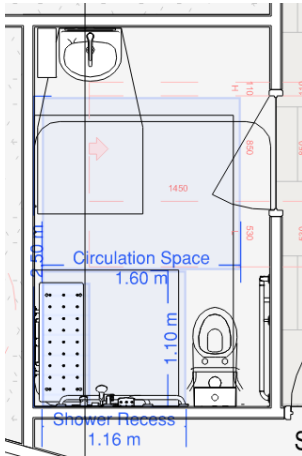
Part F4 – Sanitary and Other Facilities			
Clause	Description	Status	Comments
			<ul style="list-style-type: none"> – Doors are to have a staged closer, if it opens outwards, must also incorporate a closer which hold the door closed without pulling the door closed via a handle. – Doors shall be provided with an in-use indicator and a bolt or catch. Where a snib catch is used, the snib handle shall have a minimum length of 45 mm from the centre of the spindle. In an emergency, the latch mechanism shall be openable from the outside. – Toilet pan and wash basin are located in accordance with the diagrams with the required clearances, – All hand rails are installed and are structural (110N), – Flushing control are automatic or push action in the required zone, – An emergency light is also to be installed within the toilet. – A mirror is to be installed not less than 350mm wide by 900mm tall. <ul style="list-style-type: none"> ○ Located above the sink, ○ Flat against the wall. – A shelf is to be installed next to the basin @ 900-1000mm from the floor with a minimum width of 120-150mm by 300-400mm. – Where provided, soap dispensers, towel dispensers, hand dryers and similar fittings shall be operable by one hand, and shall be installed with the height of their operative component or outlet not less than 900 mm and not more than 1100 mm above the plane of the finished floor, and no closer than 500 mm from an internal corner. – A clothes-hanging device shall be installed 1200 mm to 1350 mm above the plane of the finished floor and not less than 500 mm out from any internal corner.
F4D7	Accessible unisex showers	CRA	<p>An accessible unisex shower is required to be provided to a class 9b early childhood centre as required by F4D4(9)(b) and F4D7(1)(d).</p>  <p>Full compliance with AS1428.1:2009 is to be indicated on the Construction Certificate Plans.</p>



Part F4 – Sanitary and Other Facilities

Clause	Description	Status	Comments
--------	-------------	--------	----------

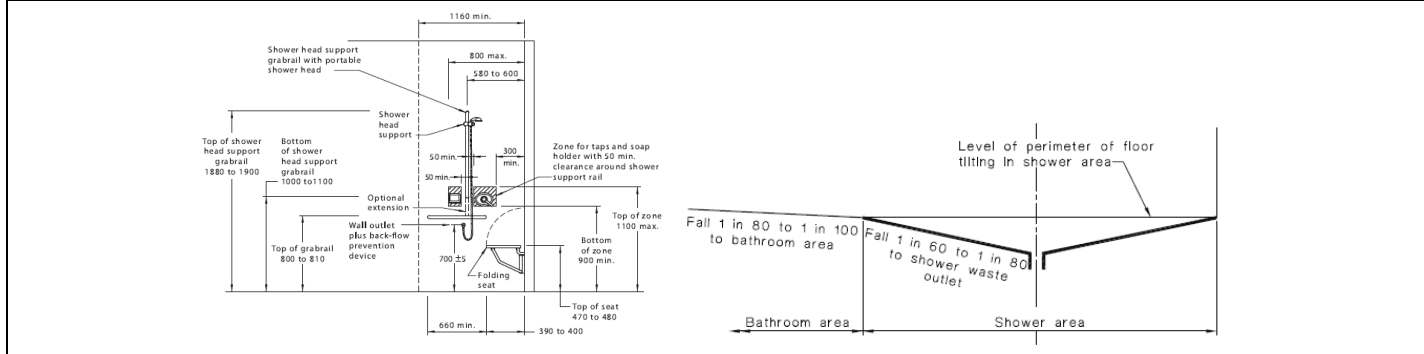
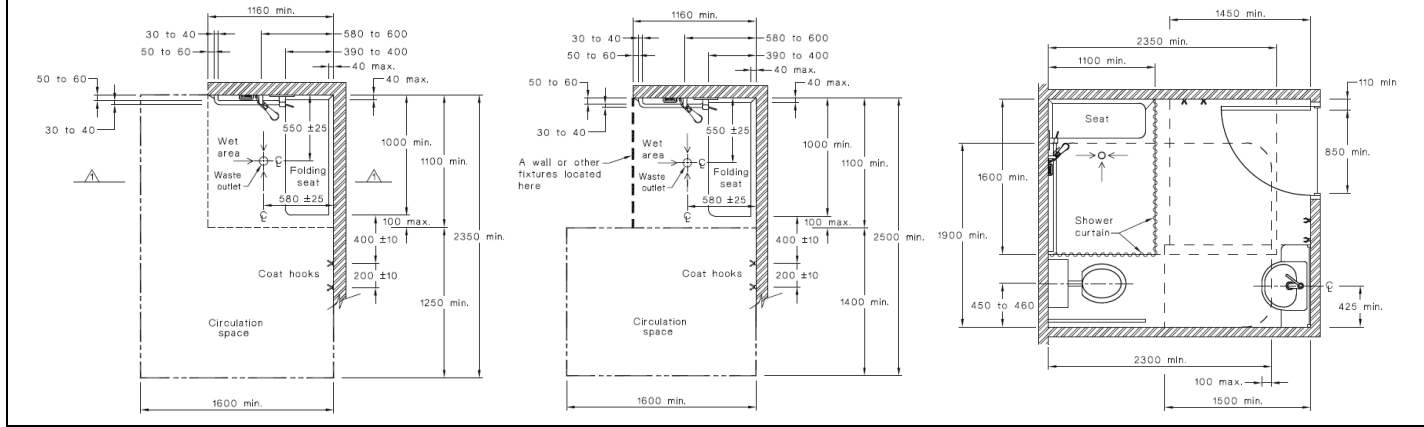

Details for an Accessible Shower: (Checklist)

- Shower recess and circulation spaces to be provided in accordance with the diagrams with the required clearances.
- Grabrails, shower hose fittings, taps, soap holder, shelf (if provided) and the folding seat are the only fixtures permitted in the spaces.
- Not less than two clothes-hanging devices to be provided within reach of the shower seat. Clothes-hanging device shall be installed 1200 mm to 1350 mm above the plane of the finished floor and not less than 500 mm out from any internal corner.
- The floor of the shower recess and associated circulation spaces are to be self-draining. The bathroom area is to be provided with a gradient between 1 in 80 to 1 in 100, and the shower area is to be provided with a gradient between 1 in 60 to 1 in 80.
- The shower entry recess is to be provided without a step-down, raised step kerb or hob.
- Waste outlet for the shower to be provided in accordance with the diagram.
- Curtain or door to be provided which maintains the required circulation spaces.
- Shower head grabrails are installed and are structural (110N),
- Adjustable hand-held shower head to be provided with a flexible hose of min 1500mm length, to be located at heights between 1000mm and 1800mm above the finished floor.
- Tap be installed in the required zone.
- Folding seat are installed and are structural (1 100N),

Part F4 – Sanitary and Other Facilities			
Clause	Description	Status	Comments
F4D8	Construction of sanitary compartments	CRA	Doors to the fully enclosed toilets are to open outwards, slide or be readily removable from the outside of the sanitary compartment unless there is a clear space of at least 1.2m between the closet pan within the sanitary compartment and the nearest part of the doorway. Design verification to be provided prior to the issue of the Construction Certificate.
F4D9	Interpretation: Urinals and washbasins	Noted	
F4D10	Microbial (legionella) control	N / A	
F4D11	Waste management	N / A	
F4D12	Accessible adult change facilities	N / A	

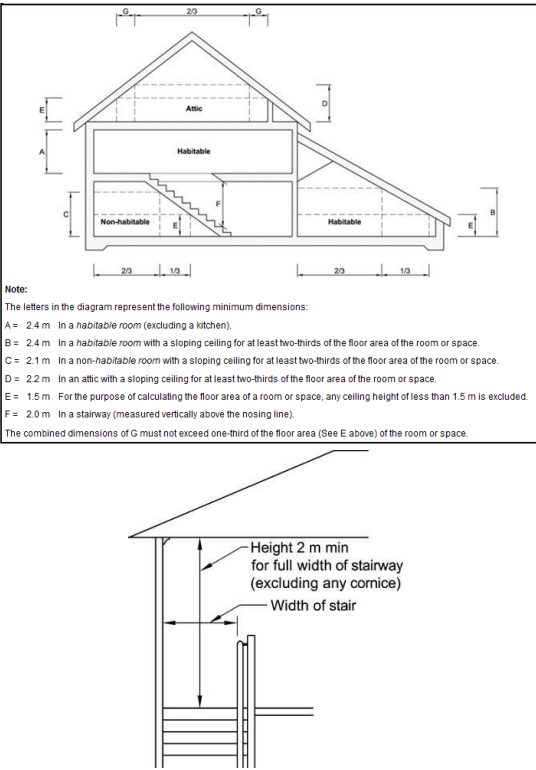
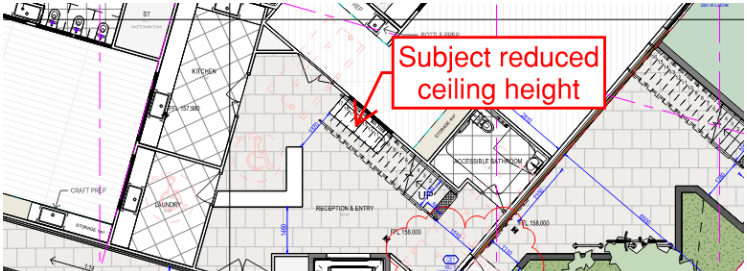
Part F5 – Room heights			
Clause	Description	Status	Comments
F5D1	Deemed-to-Satisfy Provisions	Noted	
F5D2	Height of rooms and other spaces	CRA	Ceiling heights must be not less than—
 <p>Note: The letters in the diagram represent the following minimum dimensions: A = 2.4 m In a habitable room (excluding a kitchen). B = 2.4 m In a habitable room with a sloping ceiling for at least two-thirds of the floor area of the room or space. C = 2.1 m In a non-habitable room with a sloping ceiling for at least two-thirds of the floor area of the room or space. D = 2.2 m In an attic with a sloping ceiling for at least two-thirds of the floor area of the room or space. E = 1.5 m For the purpose of calculating the floor area of a room or space, any ceiling height of less than 1.5 m is excluded. F = 2.0 m In a stairway (measured vertically above the nosing line). The combined dimensions of G must not exceed one-third of the floor area (See E above) of the room or space.</p> <p>Height 2 m min for full width of stairway (excluding any cornice) Width of stair</p>		<p>(3) The height of rooms and other spaces in a Class 5, 6, 7 or 8 building must be not less than—</p> <ul style="list-style-type: none"> (a) except as allowed in (b) and (8) — 2.4 m; and (b) a corridor, passageway, or the like — 2.1 m; and <p>(5) The height of rooms and other spaces in a Class 9b building must be not less than—</p> <ul style="list-style-type: none"> (a) a school classroom or other assembly building or part that accommodates not more than 100 people—2.4m; and (b) a theatre, public hall or other assembly building or part that accommodates more than 100 persons – 2.7m; and (c) a corridor — <ul style="list-style-type: none"> (i) that serves an assembly building or part that accommodates not more than 100 people — 2.4m; (ii) that serves an assembly building or part that accommodates more than 100 persons—2.7m; and <p>(8) in any building—</p> <ul style="list-style-type: none"> (a) a bathroom, shower room, sanitary compartment, airlock, tea preparation room, pantry, store room, garage, car parking area, or the like — 2.1 m; and (b) a commercial kitchen — 2.4 m; and (c) above a stairway, ramp, landing or the like — 2 m measured vertically above the nosing line of stairway treads or the floor surface of the ramp, landing or the like.  <p>Subject reduced ceiling height</p> <p>Design verifying compliance must be provided prior to the issue of the Construction Certificate.</p>	

Part F6 – Light and Ventilation																															
Clause	Description	Status	Comments																												
F6D1	Deemed-to-Satisfy Provisions	Noted																													
F6D2	Provision of natural light	CRA	Natural light must be provided to all general purpose rooms in all playrooms or the like for use of children in an early childhood centre.																												
F6D3	Methods and extent of natural light	CRA	<p>Required natural light must be provided by windows/glazing that have an aggregate light transmitting area measured exclusive of framing members, glazing bars or other obstructions of not less than 10% of the floor area of the room.</p> <p>The subject playrooms required to be provided with natural light appear to retain sufficient natural lighting as indicated within the table below:</p> <p>Design verifying compliance must be provided prior to the issue of the Construction Certificate.</p> <p>Note: required glazing can be as roof lights only, as wall glazing only or proportional combination of the two.</p>																												
<table border="1"> <thead> <tr> <th rowspan="2">Location</th> <th rowspan="2">Floor Area</th> <th colspan="2">Required Glazing Area</th> <th colspan="2">Provided Glazing Area</th> </tr> <tr> <th>Windows</th> <th>Roof Lights</th> <th>Windows:</th> <th>Roof Lights:</th> </tr> </thead> <tbody> <tr> <td>Playroom 1</td> <td>68.0m²</td> <td>6.80m²</td> <td>2.04m²</td> <td>17.04m²</td> <td>0.00m²</td> </tr> <tr> <td>Playroom 2</td> <td>98.0m²</td> <td>9.80m²</td> <td>2.94m²</td> <td>18.48m²</td> <td>0.00m²</td> </tr> <tr> <td>Playroom 3</td> <td>98.0m²</td> <td>9.80m²</td> <td>2.94m²</td> <td>31.20m²</td> <td>0.00m²</td> </tr> </tbody> </table> <p>Note: required glazing can be as roof lights only, as wall glazing only or proportional combination of the two.</p>				Location	Floor Area	Required Glazing Area		Provided Glazing Area		Windows	Roof Lights	Windows:	Roof Lights:	Playroom 1	68.0m ²	6.80m ²	2.04m ²	17.04m ²	0.00m ²	Playroom 2	98.0m ²	9.80m ²	2.94m ²	18.48m ²	0.00m ²	Playroom 3	98.0m ²	9.80m ²	2.94m ²	31.20m ²	0.00m ²
Location	Floor Area	Required Glazing Area				Provided Glazing Area																									
		Windows	Roof Lights	Windows:	Roof Lights:																										
Playroom 1	68.0m ²	6.80m ²	2.04m ²	17.04m ²	0.00m ²																										
Playroom 2	98.0m ²	9.80m ²	2.94m ²	18.48m ²	0.00m ²																										
Playroom 3	98.0m ²	9.80m ²	2.94m ²	31.20m ²	0.00m ²																										
F6D4	Natural light borrowed from adjoining room	Noted																													
F6D5	Artificial lighting	CRA	<p>Artificial lighting must be provided in required stairways, passageways, ramps, sanitary compartments, bathrooms, laundries and other spaces used in common by occupants of the building complying with AS1680.0 in accordance with the requirements of Clause F6D5 of the BCA.</p> <p>Details and design certification to be provided by electrical engineer prior to the issue of a Construction Certificate.</p>																												

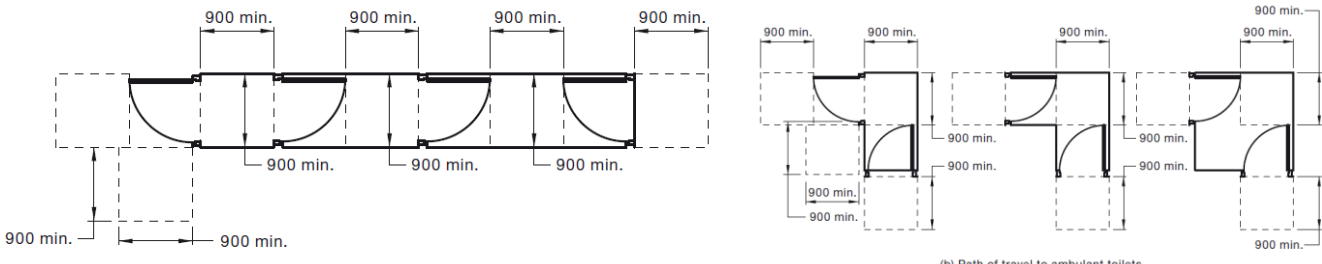

Part F6 – Light and Ventilation			
Clause	Description	Status	Comments
F6D6	Ventilation of rooms	CRA	<p>Ventilation shall be provided throughout the building by means of natural ventilation complying with Clause F6D7 or mechanical ventilation complying with the requirements of AS1668.2 and AS3666.1 as required by Clause F6D6 of the BCA.</p> <p>Details and design certification to be provided by mechanical engineer prior to the issue of a Construction Certificate.</p> <p><i>Note: Any air handling system which recycles air from one fire compartment to another or operates in a manner that may unduly contribute to the spread of smoke from one compartment to another must be designed to operate a smoke control system in accordance with AS1668.1 or incorporate smoke dampers where the air-handling ducts pass any separating element to another fire compartment and shutdown and the smoke dampeners are activated to close automatically via smoke detectors complying with clause 4.10 of AS1668.1</i></p>
F6D7	Natural ventilation	CRA	<p>Natural ventilation provided in accordance with F6D6(a) must consist of openings, windows, doors or other devices which can be opened with a ventilating area not less than 5% of the floor area or the room required to be ventilated. The subject playrooms required to be provided with natural ventilation appear to retain sufficient natural ventilation.</p> <p>Should a mechanical ventilation system be provided in accordance with F6D6(b) of the BCA, the natural ventilation requirements of this clause are not required.</p>
F6D8	Ventilation borrowed from adjoining room	CRA	<p>In a Class 7 and 9 building the window opening, door or other device has a ventilating area of not less than 10% of the floor area of the room to be ventilated, measured not more than 3.6m above the floor; and</p> <p>The adjoining room has a window opening, door or other device with a ventilating area of not less than 10% of the combined floor areas of both rooms; and</p> <p>The ventilating areas specified in (a) and (b) may be reduced as appropriate if direct natural ventilation is provided from another source.</p>
F6D9	Restriction on location of sanitary compartments	Complies	
F6D10	Airlocks	Noted	Note: Airlocks must comply with the set distances under AS1428.1 :2009

Part F6 – Light and Ventilation			
Clause	Description	Status	Comments
 <p>(b) Path of travel to ambulant toilets</p>			
F6D11	Carparks	CRA	<p>The carpark is to be provided with ventilation complying with AS1668.2 or have an adequate system of permanent natural ventilation.</p> <p>Details and design certification to be provided by mechanical engineer prior to the issue of a Construction Certificate.</p>
F6D12	Kitchen local exhaust ventilation	N / A	

Part F7 – Sound Transmission and Insulation

N / A for proposed works

Part F8 – Condensation Management

N / A for proposed works

SECTION G – ANCILLARY PROVISIONS

Part G1 – Minor Structures and Components			
Clause	Description	Status	Comments
G1D1	Deemed-to-Satisfy Provisions	Noted	
G1D2 & NSW G1D2	Swimming pools	N / A	
G1D3	Refrigerated chambers, strong-rooms and vaults	N / A	
G1D4	Outdoor play spaces	CRA	<p>Any outdoor play space in a Class 9b early childhood centre must be enclosed on all sides with a barrier which complies with AS 1926.1.</p> <p>AS 1926.1 is applied as if there is a swimming pool located outside the outdoor play space, so that the barrier restricts children from exiting the premises without the knowledge of staff in the centre.</p> <p>The above requirement does not apply to a wall, including doors and windows, which form part of the Class 9b early childhood centre.</p> <p>Compliance can be achieved by a slight redesign prior to issue of the Construction Certificate.</p>
NSW G1D5	Provision for cleaning windows	Noted	

Part G2 – Boilers, pressure vessels, heating appliances, fireplaces, chimneys and flues

N / A

Part G3 – Atrium construction

N / A

Part G4 – Construction in alpine areas

N / A

Part G5 – Construction in bushfire prone areas

N / A

Part G6 – Occupiable outdoor areas			
Clause	Description	Status	Comments
G6D1	Application of Part	Noted	<p>(1) The Deemed-to-Satisfy Provisions of this Part apply to buildings containing an occupiable outdoor area in addition to the other Deemed-to-Satisfy Provisions of NCC Volume One..</p> <p>(2) The Deemed-to-Satisfy Provisions of this Part take precedence where there is a difference to the Deemed-to-Satisfy Provision of Sections C, D, E, F and G.</p> <p>(3) Except for G6D2, the Deemed-to-Satisfy Provisions of this Part do not apply to-</p> <ul style="list-style-type: none"> (a) An occupiable outdoor area of a sole-occupancy unit in a Class 2 or 3 Building, Class 9c building or Class 4 part of a building; or (b) An occupiable outdoor area with an area less than 10m².
G6D2	Fire hazard properties	CRA	<p>(1) Subject to (2), a lining, material or assembly in an occupiable outdoor area must comply with C2D11 as for an internal element</p> <p>(2) The following fire hazard properties of a lining, material or assembly in an occupiable outdoor area are not required to comply with C2D11:</p> <ul style="list-style-type: none"> (a) Average specific extinction area. (b) Smoke-Developed Index. (c) Smoke development rate. (d) Smoke growth rate index (SMOGRA RC) <p>Details and design certification to be provided by mechanical engineer prior to the issue of a Construction Certificate.</p>
G6D3	Fire separation	CRA	<p>For the purposes of the Deemed-to-Satisfy Provisions of C3D8, C3D9, and C3D10, a reference to a storey includes an occupiable outdoor area, however a fire wall cannot be used to separate an occupiable outdoor area into different fire compartments.</p> <p>Details and design certification to be provided by mechanical engineer prior to the issue of a Construction Certificate.</p>
G6D4	Provision for escape	CRA	<p>For the purposes of the Deemed-to-Satisfy Provisions of Part D2, a reference to a storey or room includes an occupiable outdoor area.</p> <p>Details and design certification to be provided by mechanical engineer prior to the issue of a Construction Certificate.</p>
G6D5	Construction of exits	CRA	<p>For the purposes of the Deemed-to-Satisfy Provisions of Part D3, a reference to a storey or room includes an occupiable outdoor area.</p> <p>Details and design certification to be provided by mechanical engineer prior to the issue of a Construction Certificate.</p>
G6D6	Fire fighting equipment	CRA	<p>Except for S17C7(2)(a), for the purposes of the Deemed-to-Satisfy Provisions of Part E1, a reference to a storey includes an occupiable outdoor area.</p> <p>Details and design certification to be provided by mechanical engineer prior to the issue of a Construction Certificate.</p>

Part G6 – Occupiable outdoor areas			
Clause	Description	Status	Comments
G6D7	Lift Installations	CRA	For the purposes of the Deemed-to-Satisfy Provisions of Part E3, a reference to a storey includes an occupiable outdoor area. Details and design certification to be provided by mechanical engineer prior to the issue of a Construction Certificate.
G6D8	Visibility in an emergency, exit signs and warning systems	CRA	For the purposes of the Deemed-to-Satisfy Provisions of Part E4, a reference to a storey includes an occupiable outdoor area. Details and design certification to be provided by mechanical engineer prior to the issue of a Construction Certificate.
G6D9	Light and ventilation	CRA	For the purposes of the Deemed-to-Satisfy Provisions of F6D5, F6D9 and F6D10, a reference to a room includes an occupiable outdoor area. Details and design certification to be provided by mechanical engineer prior to the issue of a Construction Certificate.
G6D10	Fire orders	CRA	For the purposes of the Deemed-to-Satisfy Provisions of G4D8, a reference to a storey includes an occupiable outdoor area. Details and design certification to be provided by mechanical engineer prior to the issue of a Construction Certificate.

Part G7 – Livable housing design
This Part is not applicable to NSW.

SECTION I – SPECIAL USE BUILDINGS

N / A

SECTION J – ENERGY EFFICENCY

A detailed assessment of Section J of the BCA is beyond the scope of this report.

Please commission Section J Report prior to issue of the Construction Certificate for the requirements of this part.



4.0. CONCLUSION

Although demonstrating compliance with the BCA at DA assessment stage is not a prescribed head of consideration under Section 4.15 (formally Section 79C) of the Environmental Planning & Assessment Act 1979, Council has an obligation to consider whether the proposal, as lodged, is indicatively capable of complying with the BCA - without significant modification to those plans for which approval is sought.

In this instance we are confident that any modifications and advancement in level of details required to the proposal in order to satisfy the requirements of the BCA (in force at the time the Construction Certificate application is lodged) will not necessitate the need for any significant design changes that in turn would necessitate the submission of an application under Section 4.55 (formally Section 96) of the Environmental Planning and Assessment Act 1979.

In the same regard, we draw Council's attention to the requirements of Section 19 of the Environmental Planning & Assessment (Development Certification and Fire Safety) Regulation 2021, and suggest that detailed & specific BCA compliance matters shall be addressed to the satisfaction of the appointed Certifying Authority prior to the issue of the Construction Certificate.

Further, it is considered that this BCA review and the additional preparation of the required Construction Certificate documentation will be sufficient to ensure that the proposed design will achieve the necessary compliance with the BCA.

PREPARED BY:

Jennifer Lee
Junior Consultant
Building Innovations Australia Pty Ltd

ASSESSED BY:

Mardiros Tatian
Director
Building Innovations Australia Pty Ltd
M.Fire.Eng (Master of Fire Engineering)
Grad.Dip.Bld.Survey (Graduate Diploma of Building Surveying)
B.Med.Sci (Bachelor of Medical Science)
Building Professionals Board, NSW- A1 Accredited Certifier
BPB 2572



APPENDIX A – FIRE RESISTANCE LEVELS (TYPE A CONSTRUCTION)

Table S5C11a: TYPE A CONSTRUCTION: FRL OF LOADBEARING PARTS OF EXTERNAL WALLS

Distance from a <i>fire-source feature</i>	FRL (in minutes): <i>Structural adequacy / Integrity / Insulation</i>			
	Class 2, 3 or 4 part	Class 5, 7a or 9	Class 6	Class 7b or 8
Less than 1.5 m	90/90/90	120/120/120	180/180/180	240/240/240
1.5 to less than 3 m	90/60/60	120/90/90	180/180/120	240/240/180
3 m or more	90/60/30	120/60/30	180/120/90	240/180/90

Table S5C11b: TYPE A CONSTRUCTION: FRL OF NON-LOADBEARING PARTS OF EXTERNAL WALLS

Distance from a <i>fire-source feature</i>	FRL (in minutes): <i>Structural adequacy / Integrity / Insulation</i>			
	Class 2, 3 or 4 part	Class 5, 7a or 9	Class 6	Class 7b or 8
Less than 1.5 m	-/90/90	-/120/120	-/180/180	-/240/240
1.5 to less than 3 m	-/60/60	-/90/90	-/180/120	-/240/180
3 m or more	-/-/-	-/-/-	-/-/-	-/-/-

Table S5C11c: TYPE A CONSTRUCTION: FRL OF EXTERNAL COLUMNS NOT INCORPORATED IN AN EXTERNAL WALL

Column type	FRL (in minutes): <i>Structural adequacy / Integrity / Insulation</i>			
	Class 2, 3 or 4 part	Class 5, 7a or 9	Class 6	Class 7b or 8
<i>Loadbearing</i>	90/-/-	120/-/-	180/-/-	240/-/-
<i>Non-loadbearing</i>	-/-/-	-/-/-	-/-/-	-/-/-

Table S5C11d: TYPE A CONSTRUCTION: FRL OF COMMON WALLS AND FIRE WALLS

Wall type	FRL (in minutes): <i>Structural adequacy / Integrity / Insulation</i>			
	Class 2, 3 or 4 part	Class 5, 7a or 9	Class 6	Class 7b or 8
<i>Loadbearing or non-loadbearing</i>	90/90/90	120/120/120	180/180/180	240/240/240



Table S5C11e: TYPE A CONSTRUCTION: FRL OF LOADBEARING INTERNAL WALLS

Location	FRL (in minutes): <i>Structural adequacy / Integrity / Insulation</i>			
	Class 2, 3 or 4 part	Class 5, 7a or 9	Class 6	Class 7b or 8
<i>Fire-resisting lift and stair shafts</i>	90/90/90	120/120/120	180/120/120	240/120/120
Bounding <i>public corridors</i> , public lobbies and the like	90/90/90	120/-/-	180/-/-	240/-/-
Between or bounding <i>sole-occupancy units</i>	90/90/90	120/-/-	180/-/-	240/-/-
Ventilating, pipe, garbage, and like <i>shafts</i> not used for the discharge of hot products of combustion	90/90/90	120/90/90	180/120/120	240/120/120

Table S5C11f: TYPE A CONSTRUCTION: FRL OF NON-LOADBEARING INTERNAL WALLS

Location	FRL (in minutes): <i>Structural adequacy / Integrity / Insulation</i>			
	Class 2, 3 or 4 part	Class 5, 7a or 9	Class 6	Class 7b or 8
<i>Fire-resisting lift and stair shafts</i>	-/90/90	-/120/120	-/120/120	-/120/120
Bounding <i>public corridors</i> , public lobbies and the like	-/60/60	-/-/-	-/-/-	-/-/-
Between or bounding <i>sole-occupancy units</i>	-/60/60	-/-/-	-/-/-	-/-/-
Ventilating, pipe, garbage, and like <i>shafts</i> not used for the discharge of hot products of combustion	-/90/90	-/90/90	-/120/120	-/120/120

Table S5C11g: TYPE A CONSTRUCTION: FRL OF OTHER BUILDING ELEMENTS NOT COVERED BY TABLES S5C11a to S5C11f

Building element	FRL (in minutes): <i>Structural adequacy / Integrity / Insulation</i>			
	Class 2, 3 or 4 part	Class 5, 7a or 9	Class 6	Class 7b or 8
Other <i>loadbearing</i> internal walls, internal beams, trusses and columns	90/-/-	120/-/-	180/-/-	240/-/-
Floors	90/90/90	120/120/120	180/180/180	240/240/240
Roofs	90/60/30	120/60/30	180/60/30	240/90/60

Note: Under Specification 5, there are many individual additional requirements and concessions which need to be assessed and read in conjunction with this Specification. Your engineer is to confirm compliance with all required Fire Rated Elements.

General Requirements:

- Exposure to Fire-source features
- Fire Protection for a supporting of another part
- Lintels
- Attachments not to impair fire-resistance
- General concessions



Fire-resistance of building elements:

In a building required to be of Type A construction

- (a) each building element listed in Tables S5C11a-S5C11g and any beam or column incorporated in it, must have an FRL not less than that listed in the Tables for the particular Class of building concerned; and*
- (b) external walls, common walls and the flooring and floor framing of lift pits must be non-combustible; and*
- (c) any internal wall required to have an FRL with respect to integrity and insulation must extend to;
 - (i) the underside of the floor next above; or*
 - (ii) the underside of a roof complying with Tables S5C11a-S5C11g; or*
 - (iii) if under Clause 3.5 the roof is not required to comply with Tables S5C11a-S5C11g, the underside of the non-combustible roof covering and, except for roof battens with dimensions of 75 mm x 50 mm or less or sarking-type material, must not be crossed by timber or other combustible building elements; or*
 - (iv) a ceiling that is immediately below the roof and has a resistance to the incipient spread of fire to the roof space between the ceiling and the roof of not less than 60 minutes; and**
- (d) a loadbearing internal wall and a loadbearing fire wall (including those that are part of a loadbearing shaft) must be of concrete or masonry; and*
- (e) a non-loadbearing
 - (i) internal wall required to be fire-resisting; and*
 - (ii) lift, ventilating, pipe, garbage, or similar shaft that is not for the discharge of hot products of combustion, must be of non-combustible construction; and**
- (f) the FRLs specified in Tables S5C11a-S5C11g for an external column apply also to those parts of an internal column that face and are within 1.5 m of a window and are exposed through that window to a fire-source feature.*



APPENDIX B – SCHEDULE 2: REFERENCED DOCUMENTS

Table 1 SCHEDULE OF REFERENCED DOCUMENTS

No.	Date	Title	Volume One	Volume Two	Housing Provisions	Volume Three
AS/NZS ISO 717 Part 1	2004	Acoustics — Rating of sound insulation in buildings and of building elements — Airborne sound insulation. (See Note 1)	F7V1, F7V2, F7V3, F7V4, F7D3	H4V4	10.7.2	N/A
AS ISO 717 Part 2	2004	Acoustics — Rating of sound insulation in buildings and of building elements — Impact sound insulation	F7V1, F7V3, F7D4	N/A	N/A	N/A
AS 1056 Part 1	1991	Storage water heaters — General requirements (incorporating amendments 1, 2, 3, 4 and 5)	N/A	N/A	N/A	B2D2
AS/NZS 1170 Part 0	2002	Structural design actions — General principles (incorporating amendments 1, 3 and 4)	B1V1, B1D2, Spec 4	H1V1, H1D7	2.2.2	N/A
AS/NZS 1170 Part 1	2002	Structural design actions — Permanent, imposed and other actions (incorporating amendments 1 and 2)	B1D3	N/A	2.2.3, 2.2.4, 8.3.1, 11.2.2, 11.2.3, 11.3.4	N/A
AS/NZS 1170 Part 2	2021	Structural design actions — Wind actions	B1D3, B1D4, Spec 4, F3V1, Schedule 1	H1D7, H2V1, Schedule 1	2.2.3, Schedule 1	Schedule 1
AS/NZS 1170 Part 3	2003	Structural design actions — Snow and ice actions (incorporating amendments 1 and 2)	B1D3	N/A	2.2.3	
AS 1170 Part 4	2007	Structural design actions — Earthquake actions in Australia (incorporating amendments 1 and 2)	B1D3	H1D4, H1D5, H1D6, H1D9	2.2.3	N/A
AS 1191	2002	Acoustics — Method for laboratory measurement of airborne sound transmission insulation of building elements	Spec 29	N/A	N/A	N/A
AS 1273	1991	Unplasticized PVC (UPVC) downpipe and fittings for rainwater	N/A	N/A	7.4.2	N/A
AS 1288	2021	Glass in buildings — Selection and installation	B1D4, Spec 11, Spec 12	H1D8	8.3.1	N/A
AS 1289.6.3.3	1997	Methods of testing soils for engineering purposes — Method 6.3.3: Soil strength and consolidation tests — Determination of the penetration resistance of a soil — Perth sand penetrometer test (incorporating amendment 1)	N/A	N/A	4.2.4	N/A
No.	Date	Title	Volume One	Volume Two	Housing Provisions	Volume Three
AS 1397	2021	Continuous hot-dip metallic coated steel sheet and strip — Coatings of zinc and zinc alloyed with aluminium and magnesium (See Note 10)	N/A	N/A	7.2.2	N/A
AS 1428 Part 1	2009	Design for access and mobility — General requirements for access — New building work (incorporating amendments 1 and 2)	D3D11, D3D16, D3D22, D4D2, D4D3, D4D4, D4D7, D4D10, D4D11, D4D13, Spec 16, E3D10, F4D5, G4D5, Schedule 1	Schedule 1	Schedule 1	Schedule 1, E1D2
AS 1428 Part 1	2001	Design for access and mobility — General requirements for access — New building work	I2D7, I2D8, I2D10, I2D15	N/A	N/A	E1D2
AS 1428 Part 1 (Supplement 1)	1993	Design for access and mobility — General requirements for access — Buildings — Commentary	I2D2	N/A	N/A	N/A
AS 1428 Part 2	1992	Design for access and mobility — Enhanced and additional requirements — Buildings and facilities	I2D2, I2D3, I2D4, I2D5, I2D7, I2D10, I2D11, I2D12, I2D13, I2D14	N/A	N/A	E1D2
AS 1428 Part 4	1992	Design for access and mobility — Tactile ground surface indicators for the orientation of people with vision impairment	I2D11	N/A	N/A	N/A
AS/NZS 1428 Part 4.1	2009	Design for access and mobility — Means to assist the orientation of people with vision impairment — Tactile ground surface indicators (incorporating amendments 1 and 2)	D4D9	N/A	N/A	N/A
AS 1530 Part 1	1994	Methods for fire tests on building materials, components and structures — Combustibility test for materials	Schedule 1	Schedule 1	Schedule 1	Schedule 1
AS 1530 Part 2	1993	Methods for fire tests on building materials, components and structures — Test for flammability of materials (incorporating amendment 1)	Schedule 1	Schedule 1	Schedule 1	Schedule 1



No.	Date	Title	Volume One	Volume Two	Housing Provisions	Volume Three
AS/NZS 1530 Part 3	1999	Methods for fire tests on building materials, components and structures — Simultaneous determination of ignitability, flame propagation, heat release and smoke release	Schedule 1, Spec 3	Schedule 1, Spec 3	Schedule 1	Schedule 1, Spec 3
AS 1530 Part 4	2014	Methods for fire tests on building materials, components and structures — Fire resistance tests for elements of construction	C4D15, C4D16, Spec 9, Spec 10, Spec 13, Spec 14, Schedule 1, Spec 3	9.3.2, Schedule 1, Spec 3	Schedule 1	Schedule 1, Spec 3
AS 1530 Part 8.1	2018	Methods for fire tests on building materials, components and structures — Tests on elements of construction for buildings exposed to simulated bushfire attack — Radiant heat and small flaming sources	Spec 43	N/A	N/A	N/A
AS/NZS 1546 Part 1	2008	On-site domestic wastewater treatment units - Septic tanks	N/A	N/A	N/A	C3D2
AS/NZS 1546 Part 2	2008	On-site domestic wastewater treatment units - Waterless composting toilets	N/A	N/A	N/A	C3D3
AS 1546 Part 3	2017	On-site domestic wastewater treatment units - Secondary treatment systems (incorporating amendment 1)	N/A	N/A	N/A	C3D4
AS 1546 Part 4	2016	On-site domestic wastewater treatment units - Domestic greywater treatment systems	N/A	N/A	N/A	C3D5
AS/NZS 1547	2012	On-site domestic wastewater management	N/A	N/A	N/A	C3D6
AS 1562 Part 1	2018	Design and installation of sheet roof and wall cladding — Metal (See Note 2)	B1D4, F3D2, F3D5	H1D7	N/A	N/A
AS1562 Part 3	2006	Design and installation of sheet roof and wall cladding — Plastic	B1D4, F3D2	H1D7	N/A	N/A
AS 1657	2018	Fixed platforms, walkways, stairways and ladders — Design, construction and installation	D2D21, D2D22, D3D23, I1D6, I3D5	N/A	N/A	N/A
AS/NZS 1664 Part 1	1997	Aluminium structures — Limit state design (incorporating amendment 1)	B1D4	N/A	2.2.4	N/A
AS/NZS 1664 Part 2	1997	Aluminium structures — Allowable stress design (incorporating amendment 1)	B1D4	N/A	2.2.4	N/A
No.	Date	Title	Volume One	Volume Two	Housing Provisions	Volume Three
AS 1668 Part 1	2015	The use of ventilation and air conditioning in buildings — Fire and smoke control in buildings (incorporating amendment 1)	C3D13, C4D15, Spec 11, D2D12, Spec 19, E2D3, E2D4, E2D6, E2D7, E2D8, E2D9, E2D11, E2D12, E2D13, E2D16, E2D17, E2D19, F6D12, Spec 21, Spec 31	N/A	N/A	N/A
AS 1668 Part 2	2012	The use of ventilation and air conditioning in buildings — Mechanical ventilation in buildings (incorporating amendments 1 and 2)	E2D12, F6V1, F6D6, F6D11, F6D12, F8D4, J6D4	H4V3, H4D7	10.8.2	N/A
AS 1668 Part 4	2012	The use of ventilation and air conditioning in buildings — Natural ventilation of buildings	F6D11	N/A	N/A	N/A
AS 1670 Part 1	2018	Fire detection, warning, control and intercom systems — System design, installation and commissioning — Fire (incorporating amendment 1) (See Note 3)	C4D6, C4D7, C4D8, C4D9, C4D12, D3D26, E2D3, E2D10, G4D7, Spec 12, Spec 20, Spec 23, Spec 31	N/A	9.5.1	N/A
AS 1670 Part 3	2018	Fire detection, warning, control and intercom systems — System design, installation and commissioning — Fire alarm monitoring (incorporating amendment 1) (See Note 3)	Spec 20, Spec 23	N/A	N/A	N/A
AS 1670 Part 4	2018	Fire detection, warning, control and intercom systems — System design, installation and commissioning — Emergency warning and intercom systems (incorporating amendment 1) (See Note 3)	E3V2, E4D9, Spec 31	N/A	N/A	N/A
AS/NZS 1680 Part 0	2009	Interior lighting — Safe movement	F6D5	N/A	10.5.2	N/A
AS 1684 Part 2	2021	Residential timber-framed construction — Non-cyclonic areas	B1D4, B1D5, F1D8	H1D6	2.2.5, 4.2.13, 5.6.6, 6.2.1, 6.3.6, 7.5.2, 7.5.3, 7.5.4, 10.2.19, 10.2.20	N/A



No.	Date	Title	Volume One	Volume Two	Housing Provisions	Volume Three
AS 1684 Part 3	2021	Residential timber-framed construction — Cyclonic areas	B1D4, B1D5, F1D8	H1D6	2.2.5, 4.2.13, 5.6.6, 6.2.1, 6.3.6, 7.5.2, 7.5.3, 7.5.4, 10.2.19, 10.2.20	N/A
AS 1684 Part 4	2010	Residential timber-framed construction — Simplified — Non-cyclonic areas (incorporating amendment 1)	B1D4, B1D5, F1D8	H1D6	2.2.5, 4.2.13, 5.6.6, 6.2.1, 7.5.2, 7.5.3, 7.5.4, 10.2.19, 10.2.20	N/A
AS 1720 Part 1	2010	Timber structures — Design methods (incorporating amendments 1, 2 and 3)	B1V1, B1D4	H1V1, H1D6	4.2.13, 5.3.3	N/A
AS/NZS 1720 Part 4	2019	Timber structures — Fire resistance of timber elements	Spec 1	Spec 1	N/A	Spec 1
AS 1720 Part 5	2015	Timber structures — Nailplated timber roof trusses (incorporating amendment 1)	B1D4	H1D6	N/A	N/A
AS 1735 Part 11	1986	Lifts, escalators and moving walks — Fire rated landing doors	C4D11	N/A	N/A	N/A
AS 1735 Part 12	1999	Lifts, escalators and moving walks — Facilities for persons with disabilities (incorporating amendment 1)	E3D8, I2D6	N/A	N/A	N/A
AS/NZS 1859 Part 4	2018	Reconstituted wood based panels — Specifications — Wet process fibreboard	N/A	N/A	7.5.3, 7.5.4	N/A
AS 1860 Part 2	2006	Particleboard flooring — Installation (incorporating amendment 1)	B1D4	H1D6	N/A	N/A
AS 1905 Part 1	2015	Components for the protection of openings in fire-resistant walls — Fire-resistant doorsets (incorporating amendment 1)	C4D7, Spec 12	N/A	N/A	N/A
AS 1905 Part 2	2005	Components for the protection of openings in fire-resistant walls — Fire-resistant roller shutters	Spec 12	N/A	N/A	N/A
AS 1926 Part 1	2012	Swimming pool safety — Safety barriers for swimming pools	G1D2, G1D4	H7D2	N/A	N/A
AS 1926 Part 2	2007	Swimming pool safety — Location of safety barriers for swimming pools (incorporating amendments 1 and 2)	G1D2	H7D2	N/A	N/A
AS 1926 Part 3	2010	Swimming pool safety — Water recirculation systems (incorporating amendment 1)	G1D2	H7D2	N/A	N/A
No.	Date	Title	Volume One	Volume Two	Housing Provisions	Volume Three
AS 2047	2014	Windows and external glazed doors in buildings (incorporating amendments 1 and 2) (See Note 4)	B1D4, F3V1, F3D4, J5D5	H1D8, H2V1	13.4.4	N/A
AS 2049	2002	Roof tiles (incorporating amendment 1)	F3D2	H1D7	N/A	N/A
AS 2050	2018	Installation of roof tiles	B1D4, F3D2	H1D7	7.3.2	N/A
AS 2118 Part 1	2017	Automatic fire sprinkler systems — General systems (incorporating amendments 1 and 2)	C1V3, Spec 17, Spec 18	N/A	N/A	N/A
AS 2118 Part 4	2012	Automatic fire sprinkler systems — Sprinkler protection for accommodation buildings not exceeding four storeys in height	Spec 17, Spec 18	N/A	N/A	B4D3
AS 2118 Part 5	2008 (R 2020)	Automatic fire sprinkler systems - Home fire sprinkler systems	N/A	N/A	N/A	B4D3
AS 2118 Part 6	2012	Automatic fire sprinkler systems — Combined sprinkler and hydrant systems in multistorey buildings	Spec 17	N/A	N/A	B4D3
AS 2159	2009	Piling — Design and installation (incorporating amendment 1)	B1D4	H1D12	N/A	N/A
AS/NZS 2179 Part 1	2014	Specifications for rainwater goods, accessories and fasteners — Metal shape or sheet rainwater goods, and metal accessories and fasteners	N/A	N/A	7.4.2	N/A
AS/NZS 2269 Part 0	2012	Plywood — Structural — Specifications (incorporating amendment 1)	N/A	N/A	7.5.4	N/A
AS/NZS 2293 Part 1	2018	Emergency lighting and exit signs for buildings — System design, installation and operation (incorporating amendment 1)	E4D4, E4D8, Spec 25, I3D15	N/A	N/A	N/A
AS 2312 Part 1	2014	Guide to the protection of structural steel against atmospheric corrosion by the use of protective coatings — Paint coatings	N/A	N/A	6.3.9	N/A
AS/NZS 2312 Part 2	2014	Guide to the protection of structural steel against atmospheric corrosion by the use of protective coatings — Hot dip galvanizing	N/A	N/A	6.3.9	N/A
AS/NZS 2327	2017	Composite structures — Composite steel-concrete construction in buildings (incorporating amendment 1)	B1D4, Spec 1	Spec 1	2.2.4	Spec 1



No.	Date	Title	Volume One	Volume Two	Housing Provisions	Volume Three
AS 2419 Part 1	2021	Fire hydrant installations — System design, installation and commissioning	C3D13, E1D2, Spec 18, I3D9	N/A	N/A	B4D4
AS 2441	2005	Installation of fire hose reels (incorporating amendment 1)	E1D3	N/A	N/A	B4D5
AS 2444	2001	Portable fire extinguishers and fire blankets — Selection and location	E1D14, I3D11	N/A	N/A	N/A
AS 2665	2001	Smoke/heat venting systems — Design, installation and commissioning	Spec 22, Spec 31	N/A	N/A	N/A
AS 2699 Part 1	2020	Built-in components for masonry construction — Wall ties (See Note 9)	C2D10	N/A	5.6.5	N/A
AS 2699 Part 3	2020	Built-in components for masonry construction — Lintels and shelf angles (durability requirements) (See Note 9)	C2D10	N/A	5.6.7	N/A
AS 2870	2011	Residential slabs and footings	F1D7	H1D4, H1D5	3.4.2, 4.2.2, 4.2.6, 4.2.8, 4.2.11, 4.2.14, 4.2.15, 10.2.9	N/A
AS/NZS 2890 Part 6	2009	Parking facilities — Offstreet parking for people with disabilities	D4D6	N/A	N/A	N/A
AS/NZS 2904	1995	Damp-proof courses and flashings (incorporating amendments 1 and 2)	F1D6	N/A	5.7.3, 7.5.6, 12.3.3	N/A
AS/NZS 2908 Part 1	2000	Cellulose-cement products — Corrugated sheets	B1D4	N/A	N/A	N/A
AS/NZS 2908 Part 2	2000	Cellulose-cement products — Flat sheets	Schedule 1	Schedule 1	7.5.3, 7.5.4, 7.5.5, 10.2.9, 10.2.10, Schedule 1	Schedule 1
AS/NZS 2918	2018	Domestic solid fuel burning appliances — Installation (See Note 8)	G2D2	H7D5	12.4.4, 12.4.5	N/A
AS/NZS 3013	2005	Electrical installations — Classification of the fire and mechanical performance of wiring system elements	C3D14	N/A	N/A	N/A
AS/NZS 3500 Part 0	2021	Plumbing and drainage — Glossary of terms	A1G4	A1G4	N/A	A1G4
AS/NZS 3500 Part 1	2018	Plumbing and drainage — Water services	N/A	N/A	N/A	B5D6
No.	Date	Title	Volume One	Volume Two	Housing Provisions	Volume Three
AS/NZS 3500 Part 1	2021	Plumbing and drainage — Water services	N/A	N/A	N/A	B1D3, B1D5, B1D6, B3D3, B5V1, B5D2, B5D3, B5D4, Spec 41, B6D2, B6D3, B6D5, B7D3,
AS/NZS 3500 Part 2	2021	Plumbing and drainage — Sanitary plumbing and drainage (incorporating amendment 1)	N/A	N/A	N/A	C1D3, C1V1, C1V2, C1V3, C1V4, C1V5, C2V2, C2D3, C2D4, C3D7
AS/NZS 3500 Part 3	2021	Plumbing and drainage — Stormwater drainage (See Note 11)	F1D3	H2D2, H2D6	7.4.3	N/A
AS/NZS 3500 Part 4	2021	Plumbing and drainage — Heated water services (incorporating amendment 1)	N/A	N/A	N/A	B2D2, B2D6, B2D7, B2D8, B2D9, B2D11
AS 3600	2018	Concrete structures (incorporating amendments 1 and 2)	B1V1, B1D4, Spec 1	H1V1, H1D4, Spec 1	3.4.2, 4.2.6, 4.2.10, 4.2.13, 5.3.3, 10.2.9	Spec 1
AS 3660 Part 1	2014	Termite management — New building work (incorporating amendment 1)	B1D4, F1D6	N/A	3.4.1, 3.4.2	N/A
AS 3660 Part 3	2014	Termite management — Assessment criteria for termite management systems	N/A	N/A	3.4.2	N/A
AS/NZS 3666 Part 1	2011	Air-handling and water systems of buildings — Microbial control — Design, installation and commissioning	F4D10, F6D6	N/A	N/A	N/A
AS 3700	2018	Masonry structures	B1D4, F3D5, Spec 1, Spec 2	H1D5, H2D4, Spec 1, Spec 2	5.3.3, 5.4.2, 5.6.3, 6.3.6, 10.2.9, 10.2.19, 10.2.20, 12.4.3	Spec 1, Spec 2
AS 3740	2021	Waterproofing of domestic wet areas	F2D2	H4D2, H4D3	10.2.20	N/A
AS 3786	2014	Smoke alarms using scattered light, transmitted light or ionization (incorporating amendment 1 and 2) (See Note 5)	Spec 20	N/A	9.5.1	N/A
AS/NZS 3823 Part 1.2	2012	Performance of electrical appliances — Air conditioners and heat pumps — Ducted air conditioners and air-to-air heat pumps — Testing and rating for performance	Spec 33, J6D12	N/A	N/A	N/A



No.	Date	Title	Volume One	Volume Two	Housing Provisions	Volume Three
AS 3959	2018	Construction of buildings in bushfire-prone areas (incorporating amendments 1 and 2)	C2D14, F8D5, G5D2, G5D3, Spec 43	H7D4	10.8.3	B1D4, B2D10, B3D4, C1D4, C2D5
AS/NZS 4020	2018	Testing of products for use in contact with drinking water (See Note 6)	A5G4	A5G4	N/A	A5G4
AS 4055	2021	Wind loads for housing	Schedule 1	H1D6, H1D8, Schedule 1	2.2.3, Schedule 1	Schedule 1
AS 4072 Part 1	2005	Components for the protection of openings in fire-resistant separating elements — Service penetrations and control joints (incorporating amendment 1)	C4D15, C4D16	N/A	9.3.2	N/A
AS 4100	2020	Steel structures	B1D4, Spec 1	H1D6, Spec 1	4.2.13, 5.6.7	Spec 1
AS 4200 Part 1	2017	Pliable building membranes and underlays — Materials (incorporating amendment 1)	F3D3, F8D3, Spec 36, Schedule 1	Schedule 1	7.3.4, 7.5.2, 7.5.8, 10.8.1, Schedule 1	Schedule 1
AS 4200 Part 2	2017	Pliable building membranes and underlays — Installation requirements (incorporating amendments 1 and 2)	F3D3, F8D3	N/A	10.8.1	N/A
AS/NZS 4234	2021	Heated water systems — Calculation of energy consumption	Spec 45	N/A	N/A	B2D2
AS 4254 Part 1	2021	Ductwork for air-handling systems in buildings — Flexible duct	Spec 7, J6D7	H3D2	13.7.4	N/A
AS 4254 Part 2	2012	Ductwork for air-handling systems in buildings — Rigid duct	Spec 7, J6D5, J6D7	N/A	13.7.4	N/A
AS/NZS 4284	2008	Testing of building facades	F3V1	H2V1	N/A	N/A
AS/NZS 4505	2012	Garage doors and other large access doors (incorporating amendment 1)	B1D4	N/A	2.2.4	N/A
AS 4552	2005	Gas fired water heaters for hot water supply and/or central heating	N/A	N/A	N/A	B2D2
AS 4586	2013	Slip resistance classification of new pedestrian surface materials (incorporating amendment 1) (See Note 7)	D3D11, D3D14, D3D15. Spec 27	N/A	11.2.4	N/A
AS 4597	1999	Installation of roof slates and shingles (Non-interlocking type)	B1D4, F3D2	H1D7	N/A	N/A
AS/NZS 4600	2018	Cold-formed steel structures	B1D4, Spec 1	H1D6, Spec 1	5.3.3, 6.3.6	Spec 1
No.	Date	Title	Volume One	Volume Two	Housing Provisions	Volume Three
AS 4654 Part 1	2012	Waterproofing membranes for external above-ground use — Materials	F1D5	H2D8	N/A	N/A
AS 4654 Part 2	2012	Waterproofing membranes for external above-ground use — Design and installation	C2D14, F1D4, F1D5	H2D8	N/A	N/A
AS 4678	2002	Earth-retaining structures	N/A	H1D3	N/A	N/A
AS 4773 Part 1	2015	Masonry in small buildings — Design (incorporating amendment 1)	N/A	H1D5, H2D4	5.6.3, 12.4.3	N/A
AS 4773 Part 2	2015	Masonry in small buildings — Construction (incorporating amendment 1)	N/A	H1D5, H2D4	5.6.3, 12.4.3	N/A
AS/NZS 4859 Part 1	2018	Thermal insulation materials for buildings — General criteria and technical provisions	J4D3, J6D6, J6D9	N/A	13.2.2, 13.7.2, 13.7.4	N/A
AS/NZS 4859 Part 2	2018	Thermal insulation materials for buildings — Design	J3D8, J4D3, Spec 36, Spec 37	N/A	13.2.5, 13.2.6	N/A
AS/NZS 4858	2004	Wet area membranes	N/A	N/A	10.2.8	N/A
AS 5113	2016	Classification of external walls of buildings based on reaction-to-fire performance (incorporating amendment 1)	C1V3	N/A	N/A	N/A
AS 5146 Part 1	2015	Reinforced autoclaved aerated concrete — Structures (incorporating amendment 1)	B1D4	H1D7	N/A	N/A
AS 5146 Part 3	2018	Reinforced autoclaved aerated concrete — Construction	F3D5	N/A	N/A	N/A
AS 5216	2021	Design of post-installed and cast-in fastenings in concrete	B1D4	N/A	2.2.4	N/A
AS/NZS 5601 Part 1	2013	Gas installations — General installations	J1V4	H6V3	N/A	N/A
AS 5637 Part 1	2015	Determination of fire hazard properties — Wall and ceiling linings	Spec 7, Schedule 1	Schedule 1	Schedule 1	Schedule 1
AS ISO 9239 Part 1	2003	Reaction to fire tests for floorings — Determination of the burning behaviour using a radiant heat source	Schedule 1	Schedule 1	Schedule 1	Schedule 1
AS/NZS ISO 9972	2015	Thermal performance of buildings — Determination of air permeability of buildings — Fan pressurization method	J1V4	H6V3	N/A	N/A
AIRAH-DA07	2021	Criteria for moisture control design analysis in buildings	F8V1	H4V5	N/A	N/A



No.	Date	Title	Volume One	Volume Two	Housing Provisions	Volume Three
AIRAH-DA09	1998	Air conditioning load estimation	Spec 35	N/A	N/A	N/A
AIRAH-DA28	2011	Building management and control systems	Spec 34	N/A	N/A	N/A
ANSI/ASHRAE Standard 55	2013	Thermal environmental conditions for human occupancy	Schedule 1	Schedule 1	Schedule 1	Schedule 1
ANSI/ASHRAE Standard 140	2007	Standard method of test for the evaluation of building energy analysis computer programs	J1V1, J1V2, J1V3, J1V5	H6V2	N/A	N/A
ASTM E2073-10	2010	Standard Test Method for Photopic Luminance of Photoluminescent (Phosphorescent) Markings	Spec 25	N/A	N/A	N/A
ASTM E72-15	2015	Standard Test Methods of Conducting Strength Tests of Panels for Building Construction	Spec 6	N/A	N/A	N/A
ASTM E695-03	2003	Standard Test Method of Measuring Relative Resistance of Wall, Floor and Roof Construction to Impact Loading	Spec 6	N/A	N/A	N/A
ASTM E96	2016	Standard Test Methods for Water Vapor Transmission of Materials	Schedule 1	Schedule 1	Schedule 1	Schedule 1
AHRI 460	2005	Performance rating of remote mechanical-draft air-cooled refrigerant condensers	J6D13	N/A	N/A	N/A
AHRI 551/591	2015	Performance rating of water-chilling and heat pump water-heating packages using the vapor compression cycle.	Spec 33, J6D11	N/A	N/A	N/A
ABCB	2022	Fire Safety Verification Method	C1V4	N/A	N/A	N/A
ABCB	2022	Housing Provisions Standard	N/A	Throughout	Throughout	N/A
ABCB	2022	Livable Housing Design	G7D2	H4D3, H8D2	3.3.3, 11.2.3	N/A
ABCB	2011	Protocol for Structural Software, Version 2011.2	B1D5	H1D6	2.2.5	N/A
ABCB	2012	Standard for Construction of Buildings in Flood Hazard Areas, Version 2012.3	B1D6	H1D10	N/A	N/A
ABCB	2022	Standard for NatHERS Heating and Cooling Load Limits, Version 2022.1	J3D3	Spec 42	N/A	N/A
ABCB	2022	Standard for Whole-of-Home Efficiency Factors	J3D14	N/A	13.6.2	N/A
CIBSE Guide A	2015	Environmental design	Spec 34, Spec 35, J4D3, J4D7	N/A	N/A	N/A
No.	Date	Title	Volume One	Volume Two	Housing Provisions	Volume Three
N/A	2002	Disability Standards for Accessible Public Transport	F4D12, I2D1	N/A	N/A	N/A
N/A	2010	Education and Care Services National Law Act (Vic)	Schedule 1	Schedule 1	Schedule 1	Schedule 1
European Union Commission Regulation 547/2012	2012	Eco-design requirements for water pumps	J6D8	N/A	N/A	N/A
European Union Commission Regulation 622/Annex II, point 2	2012	Eco-design requirements for glandless standalone circulators and glandless circulators integrated in products	J6D8	N/A	N/A	N/A
FPA101D	2021	Automatic Fire Sprinkler System Design and Installation — Drinking Water Supply	C1V3, C2D6, C2D13, C3D2, C3D7, C3D8, C4D6, C4D7, C4D8, C4D9, C4D12, Spec 5, Spec 7, D2D4, D2D17, D3D26, D3D30, E2D8, E2D9, E2D13, E2D14, E2D15, E2D16, E2D17, E2D19, E2D20, Spec 17, Spec 18, Spec 20, G3D1, G3D6, Spec 31, I1D2, Schedule 1	Schedule 1	Schedule 1	B4D3, Schedule 1



No.	Date	Title	Volume One	Volume Two	Housing Provisions	Volume Three
FPA101H	2018	Automatic Fire Sprinkler System Design and Installation — Hydrant Water Supply (incorporating amendment 1)	C1V3, C2D6, C2D13, C3D2, C3D7, C3D8, Spec 5, Spec 7, Spec 17, Spec 18, E2D8, E2D9, E2D13, E2D14, E2D15, E2D16, E2D17, E2D19, E2D20, Spec 20, G3D1, G3D6, Spec 31, I1D2	N/A	N/A	B4D3
ISO 140 Part 6	1998E	Acoustics — Measurement of sound insulation in buildings and of building elements — Laboratory measurements of impact sound insulation of floors	Spec 29	N/A	N/A	N/A
ISO 540	2008	Hard coal and coke — Determination of ash fusibility	Spec 13	N/A	N/A	N/A
ISO 8336	1993E	Fibre-cement flat sheets	Schedule 1	Schedule 1	7.5.3, 7.5.4, 7.5.5, Schedule 1	Schedule 1
ISO 25745 Part 2	2015	Energy performance of lifts, escalators and moving walks: Energy calculation and classification for lifts (elevators)	J7D8	N/A	N/A	N/A
NASH Standard	2021	Steel Framed Construction in Bushfire Areas	N/A	H7D4	N/A	N/A
NASH Standard Part 1	2005	Residential and Low Rise Steel Framing — Design Criteria (incorporating amendments A, B and C)	B1D4	H1D6	N/A	N/A
NASH Standard Part 2	2014	Residential and Low Rise Steel Framing — Design Solutions (incorporating amendment A)	B1D4, B1D5, F1D8	H1D6	2.2.5, 6.2.1, 6.3.6, 7.5.2, 7.5.3, 7.5.4, 10.2.19, 10.2.20	N/A
NSF/ANSI/ CAN 372	2020	Drinking Water System Components - Lead Content	A5G4	A5G4	N/A	A5G4
N/A	N/A	Northern Territory Deemed to Comply Standards Manual	N/A	N/A	2.2.4	N/A
SA TS 5344	2019	Permanent labelling for Aluminium Composite Panel (ACP) products	A5G8	A5G8	N/A	A5G8
TN 61	N/A	Cement Concrete and Aggregates Australia — Technical note — Articulated walling	N/A	H1D4	N/A	N/A

Table Notes

- (1) For AS/NZS ISO 717.1:
 - (a) Test reports based on AS 1276—1979 and issued prior to AS/NZS 1276.1—1999 being referenced in the NCC remain valid.
 - (b) The STC values in reports based on AS 1276—1979 must be considered to be equivalent to Rw values.
 - (c) Test reports based on AS/NZS 1276.1 prepared after the NCC reference date for AS/NZS 1276.1—1999 must be based on that version.
 - (d) Test reports based on ISO 717-1—1996 and issued prior to AS/NZS ISO 717.1—2004 being referenced in the NCC remain valid.
 - (e) Reports based on AS/NZS ISO 717.1 relating to tests carried out after the NCC reference date for AS/NZS ISO 717.1—2004 must relate to the amended Standard.
- (2) For AS 1562.1, tests carried out based on AS 1562.1—1992 and issued prior to AS 1562.1—2018 being referenced in the NCC remain valid. Reports relating to tests carried out after the NCC reference date for AS 1562.1 must relate to the revised Standard.
- (3) For AS 1670.1, AS 1670.3 and AS 1670.4, notwithstanding A4G1(5), until the adoption of NCC 2025 the editions of the documents listed in Table 1.8 of AS 1670.1, AS 1670.3 and AS 1670.4 may be used to meet the requirements of AS 1670.1, AS 1670.3 and AS 1670.4 as applicable.
- (4) For AS 2047:
 - (a) Tests carried out under earlier editions of AS 2047 remain valid.
 - (b) Reports based on AS 2047 relating to tests carried out after the NCC reference date for AS 2047—2014 Amendment 2 must relate to the amended Standard.
- (5) For AS 3786:
 - (a) Tests carried out under AS 3786—2014 Amendment 1 remain valid.
 - (b) Reports based on AS 3786 relating to tests carried out after the NCC reference date for AS 3786—2014 Amendment 2 must relate to the amended Standard.
- (6) Test reports based on the 2005 edition of AS/NZS 4020 will continue to be accepted until 1 May 2024. Test reports prepared after the NCC reference date for the 2018 edition of AS/NZS 4020 must be based on the 2018 edition.
- (7) For AS 4586:
 - (a) Test reports based on the 2004 edition of AS/NZS 4586 and issued prior to the 2013 edition of AS 4586 being referenced in the NCC remain valid.
 - (b) Test reports prepared after the NCC reference date of the 2013 edition of AS 4586 must be based on that version.
 - (c) For the purposes of assessing compliance, the slip-resistance classifications of V, W and X in reports based on the 2004 edition of AS/NZS 4586 may be considered to be equivalent to slip-resistance classifications of P5, P4 and P3 respectively in the 2013 edition of AS 4586.
 - (d) Test reports based on Appendix D of AS 4586—2013 and issued prior to the NCC reference date for AS 4586—2013 (incorporating Amendment 1) remain valid.
 - (e) Test reports based on Appendix D of AS 4586—2013 and prepared after the NCC reference date for AS 4586—2013 (incorporating Amendment 1) must be based on that version.
- (8) Tests carried out based on AS/NZS 2918—2001 and issued prior to AS/NZS 2918—2018 being referenced in the NCC remain valid. Reports relating to tests carried out after the NCC reference date for AS/NZS 2918 must relate to the revised Standard.
- (9) For AS 2699 Parts 1 and 3:
 - (a) For AS 2699.1, the 2000 edition has been retained for a transitional period ending on 30 April 2025.
 - (b) For AS 2699.3, the 2002 edition has been retained for a transitional period ending on 30 April 2025.
- (10) For AS 1397, the 2011 edition has been retained for a transitional period ending on 31 August 2023.
- (11) For AS/NZS 3500.3, the 2018 edition has been retained for a transitional period ending on 31 August 2023.



NSW Table 1 SCHEDULE OF REFERENCED DOCUMENTS

No.	Date	Title	Volume One	Volume Two	Housing Provisions
AS/NZS 1596	2014	The Storage and Handling of LP Gas	NSW I4D61	N/A	N/A
AS 1603	2018	Automatic fire detection and alarm systems — Heat alarms (See Note 1)	N/A	N/A	NSW 9.5.1
AS 2001 Part 5.4	2005	Methods of test for textiles: Dimensional washing and drying procedures for textile texting		N/A	N/A
AS/NZS 3000	2018	Electrical installations (known as the Australian/New Zealand Wiring Rules)	NSW I5D14	N/A	N/A
AS/NZS 3002	2008	Electrical installations — Shows and carnivals	NSW I5D14	N/A	N/A
SSL	N/A	Appraisal Specification FAS 102	NSW I4D46	N/A	N/A
NSW Legislation	1979	Environmental Planning and Assessment Act	NSW G5D3, NSW Schedule 1	NSW H7D4, NSW Schedule 1	N/A
NSW Legislation	2021	Environment Planning and Assessment Regulation	NSW I4D1, NSW I4D46, NSW Schedule 1	NSW Schedule 1	NSW Schedule 1
NSW Legislation	2007	Liquor Act	NSW Schedule 1	NSW Schedule 1	NSW Schedule 1
NSW Legislation	1997	Rural Fires Act	NSW G5D3, NSW G5D4, NSW Schedule 1	NSW Schedule 1	NSW Schedule 1
NSW Legislation	N/A	Standard Instrument— Principal Local Environmental Plan	NSW Schedule 1	NSW Schedule 1	NSW Schedule 1
NSW Legislation	1992	Swimming Pools Act	NSW G1P2, NSW G1D2, NSW Schedule 1	NSW H7P1, NSW H7D2, NSW Schedule 1	NSW Schedule 1
NSW Legislation	2018	Swimming Pools Regulation	NSW G1P2, NSW G1D2	NSW H7P1, NSW H7D2	N/A
NSW Legislation	2011	Work Health and Safety Act	NSW G1D5	N/A	N/A

Table Notes

(1) Heat alarms complying with AS 1603.3 must be a class type A1 or A2.

APPENDIX C – REFERENCED DOCUMENTATION

The following documentation was used in the preparation of this report:

Drawing No.	Title	Rev.	Project No.	Date	Drawn By
A100	BASEMENT LEVEL	4	2309 BLA	31.07.2024	SDCW
A101	GROUND LEVEL	4	2309 BLA	31.07.2024	SDCW
A102	LEVEL 1	4	2309 BLA	31.07.2024	SDCW
A200	ELEVATIONS	4	2309 BLA	31.07.2024	SDCW
A300	BUILDING SECTIONS	3	2309 BLA	31.07.2024	SDCW
A301	BUILDING SECTIONS	2	2309 BLA	31.07.2024	SDCW