

**LEGEND**

	ON SITE DETENTION TANK
	NEW STORMWATER PIPE
	NEW RISING MAIN
	NEW STORMWATER PIT
	GRATE LEVEL
	INVERT LEVEL
	NEW DOWNPIPE
	NEW OVERLAND FLOW PATH.
	NEW GRATED DRAIN
	NEW FLOOR WASTE

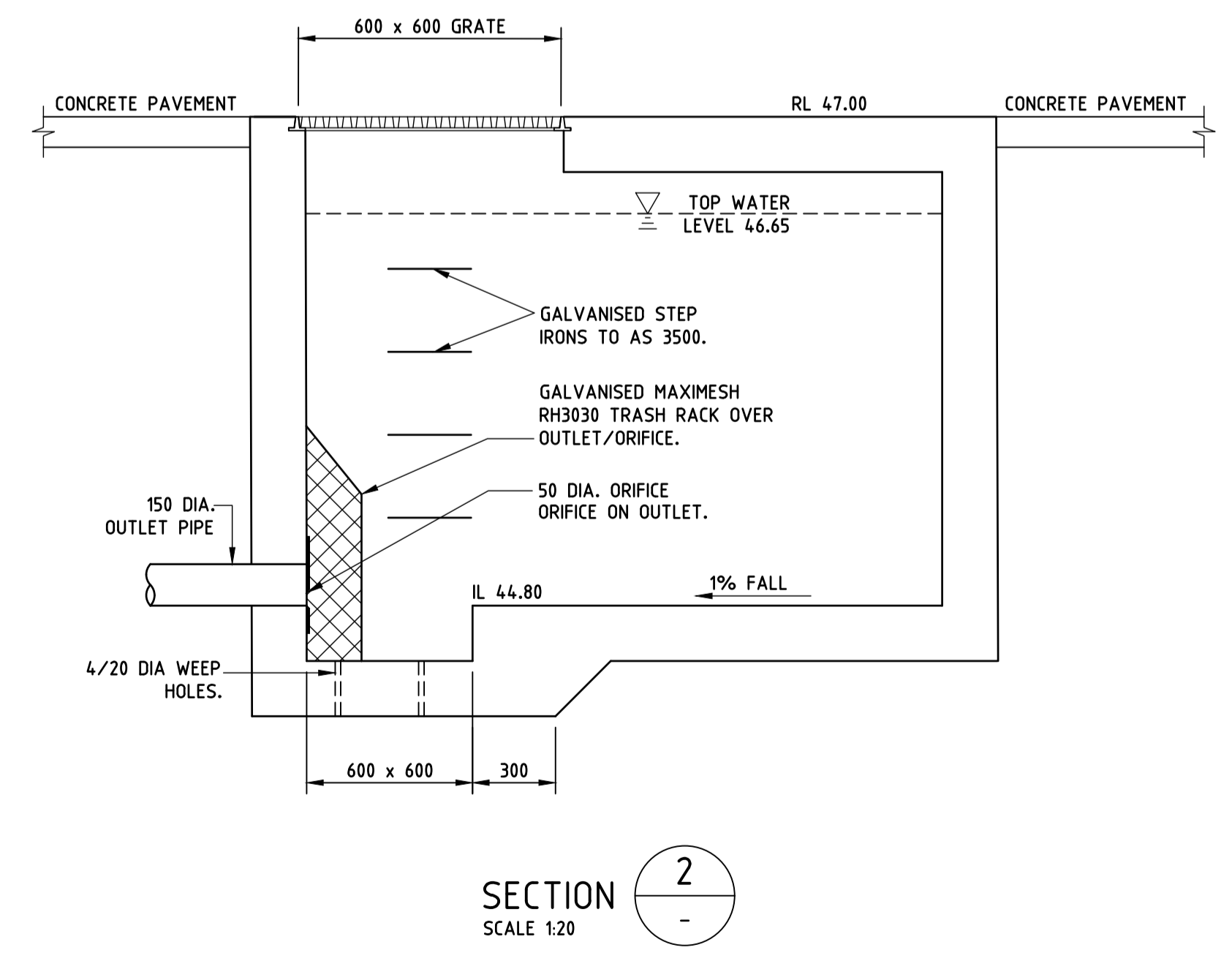

No.	Date	Description	Ver.	Appr.
A	25.01.19	ISSUE FOR DA		

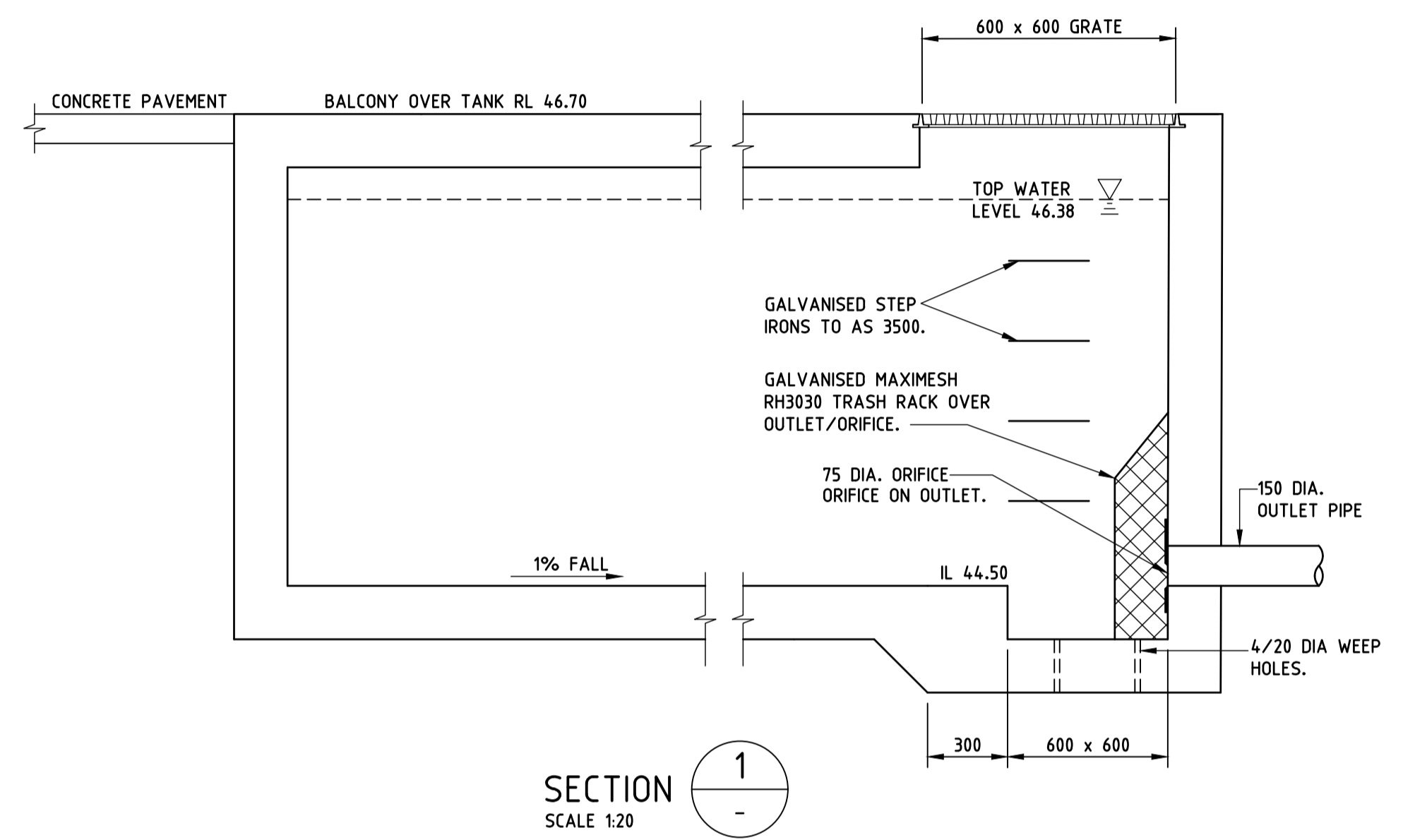
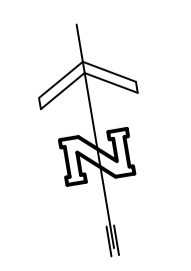

Client  
SUN PROPERTY GROUP  
LEVEL 4, 17 RANDLE STREET  
SURRY HILLS, NSW, 2010



PROPOSED RESIDENTIAL DEVELOPMENT  
307 SYDNEY ROAD AND 12 BOYLE STREET  
BALGOWLAH, NSW 2093

**STORMWATER MANAGEMENT  
PLAN - GROUND FLOOR**

Date	FEBRUARY 2018	Approved	SETB	Verified	AP	Prepared	SC
Scale @ A1	1:200, 20	25.01.19	25.01.19	25.01.19	25.01.19	16.01.19	
Job number	18-11	Drawing number	SW1	Amendment	A		

**LEGEND**

- NEW STORMWATER PIPE
- RM NEW RISING MAIN
- □ NEW STORMWATER PIT
- GL GRATE LEVEL
- IL INVERT LEVEL
- DP ○ NEW DOWNPIPE
- GD NEW GRATED DRAIN
- FW NEW FLOOR WASTE

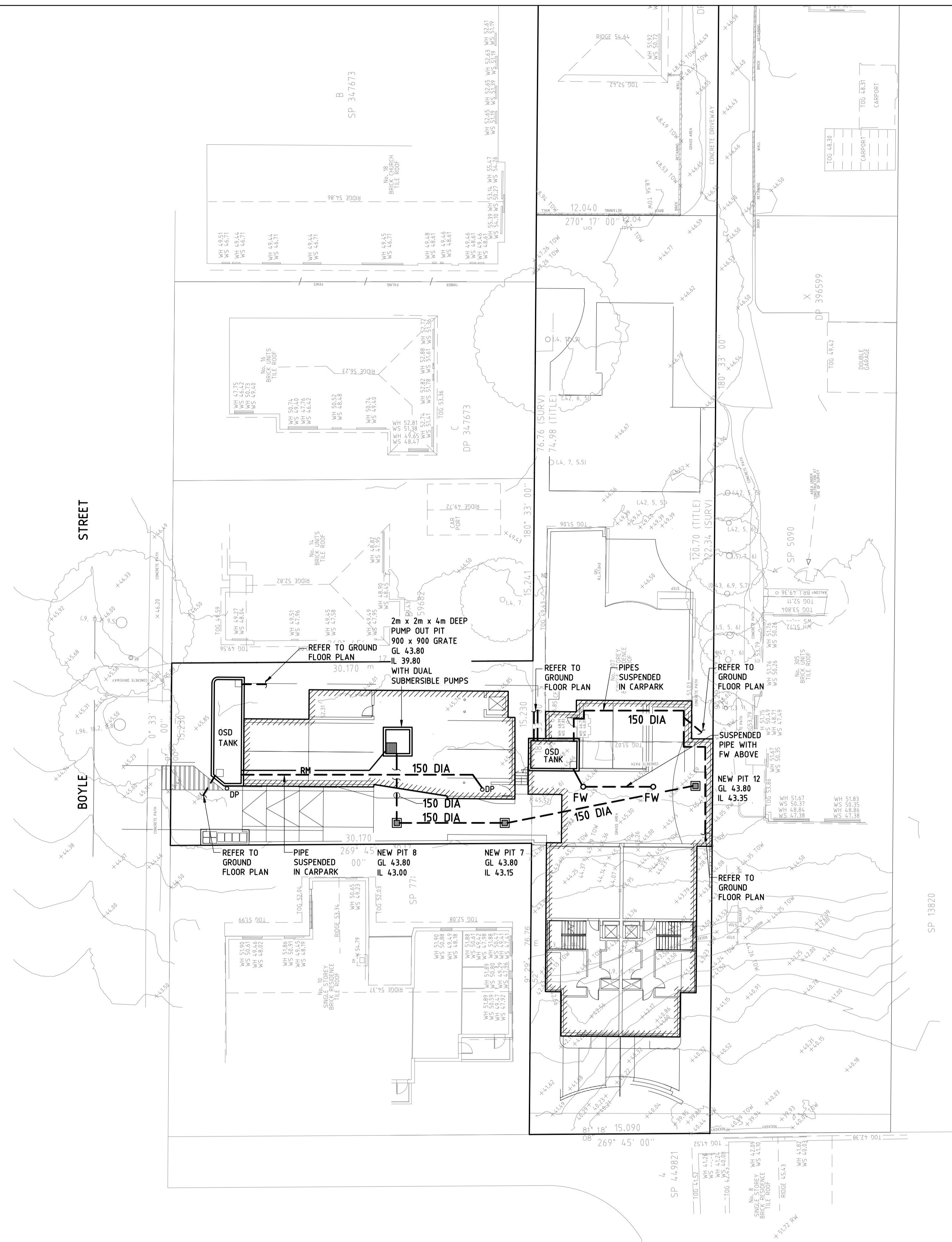

No.	Date	Description	Ver.	Appr.
A	25.01.19	ISSUE FOR DA		

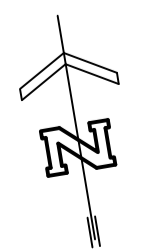

Client  
 SUN PROPERTY GROUP  
 LEVEL 4, 17 RANDLE STREET  
 SURRY HILLS, NSW, 2010



T +61 2 8203 1500 | www.woolacotts.com.au  
 Ground Floor, 12a Brown Street, Chatswood, NSW 2067  
This drawing is copyright and must not be used, reproduced or copied wholly or in part without written permission of Woolacotts Consulting Engineers Pty Ltd.

PROPOSED RESIDENTIAL DEVELOPMENT  
 307 SYDNEY ROAD AND 12 BOYLE STREET  
 BALGOWLAH, NSW 2093

STORMWATER MANAGEMENT  
 PLAN - LOWER GROUND FLOOR

Date	FEBRUARY 2018	Approved	SETB	Verified	AP	Prepared	SC
Scale	@ A1 1:200, 20	25.01.19	25.01.19	25.01.19	25.01.19	16.01.19	16.01.19
Job number	18-11	Drawing number	SW2	Amendment	A		

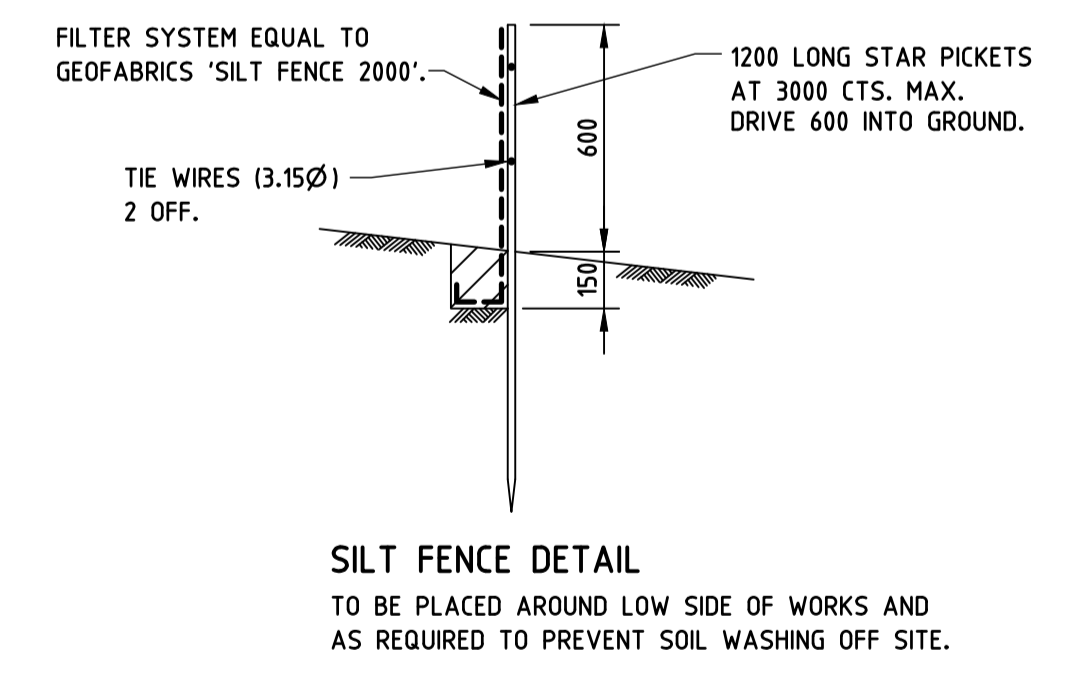
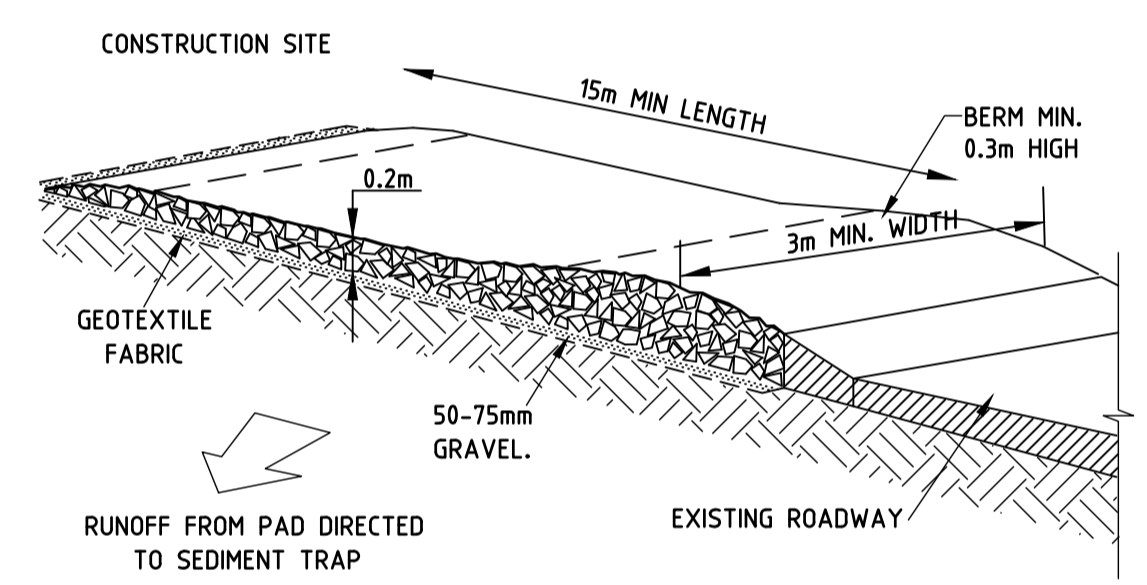
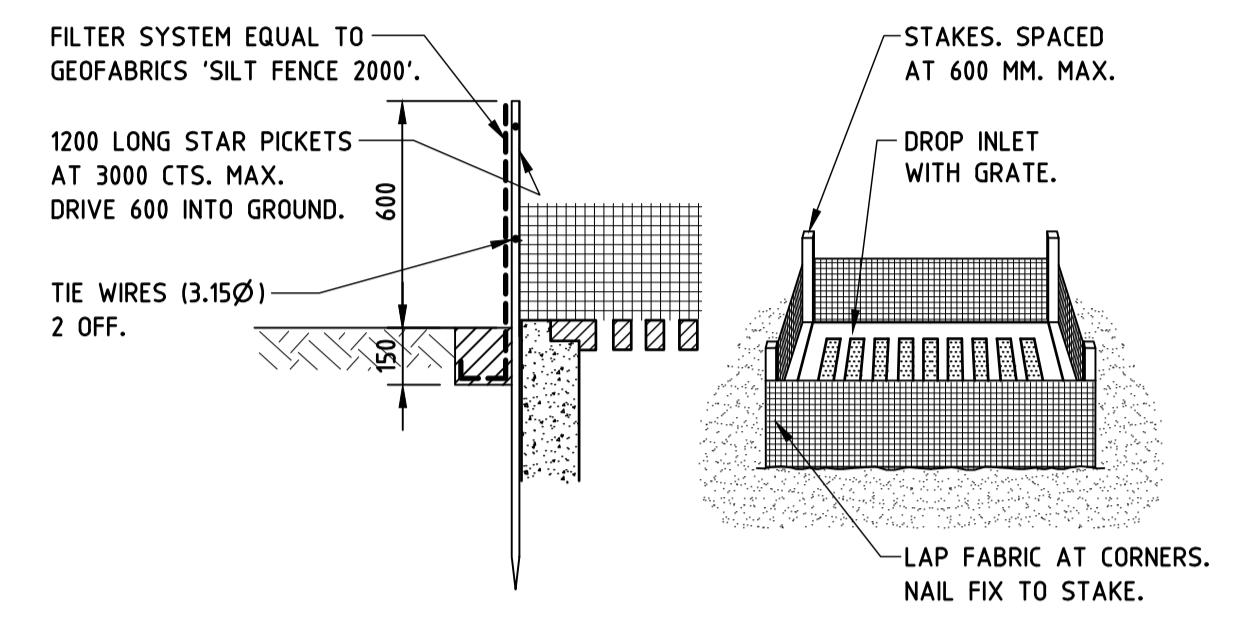
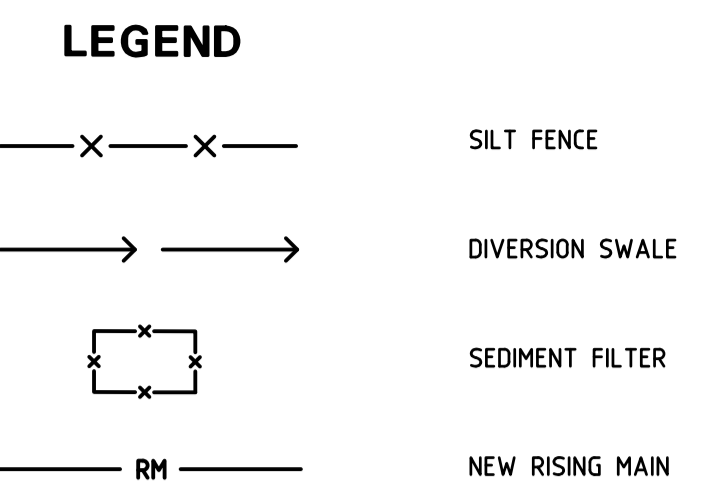
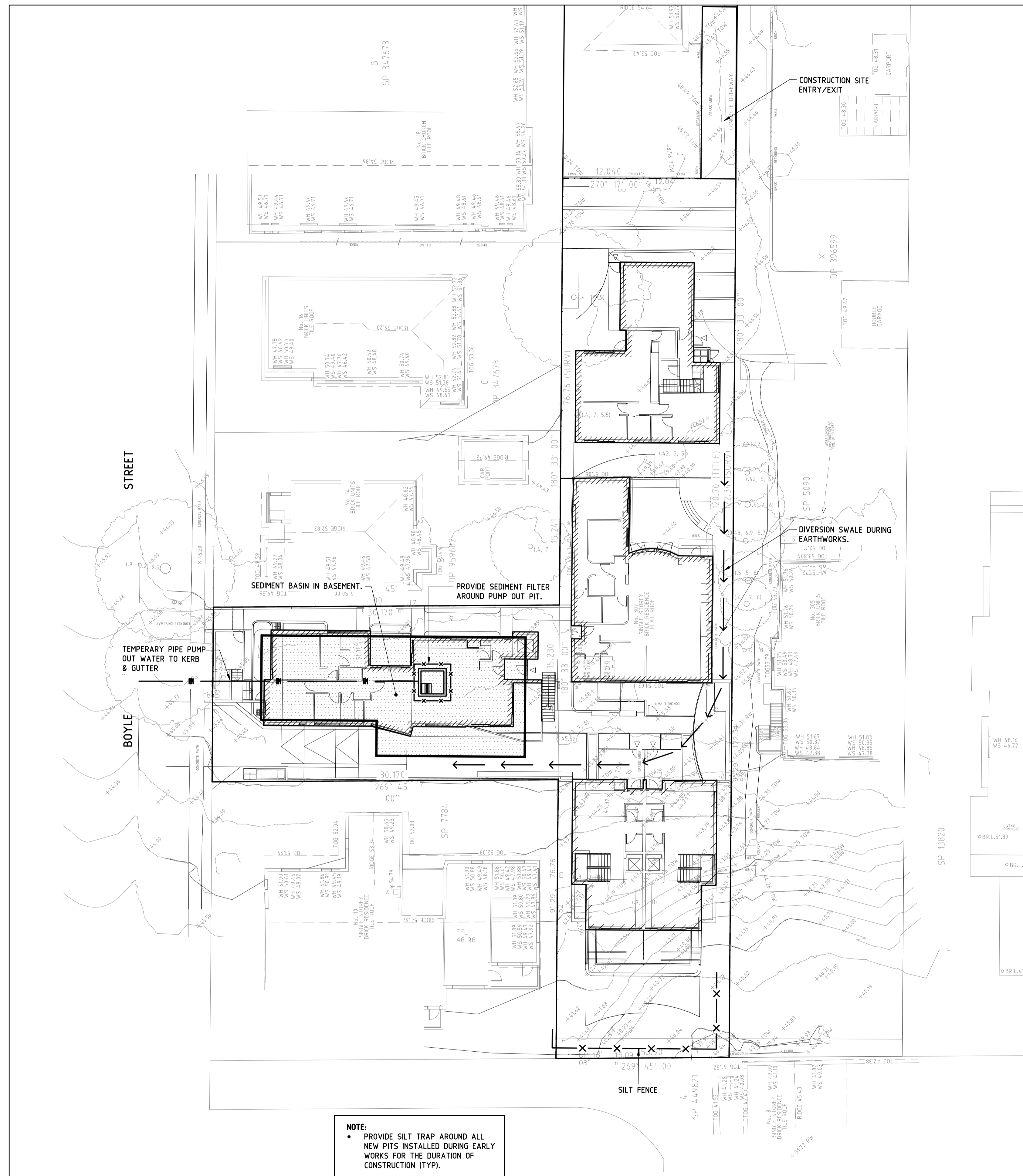

**EROSION AND SEDIMENT CONTROL DETAILS**

PROVIDE AS REQUIRED TO PREVENT SILT FROM LEAVING THE SITE.

**NOTE:**

- PROVIDE SILT TRAP AROUND ALL NEW PITS INSTALLED DURING EARLY WORKS FOR THE DURATION OF CONSTRUCTION (TYP).

No.	Date	Description	Ver.	Appr.
A	25.01.19	ISSUE FOR DA		

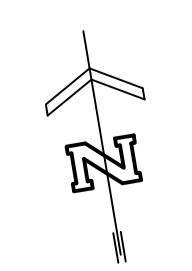

Client  
SUN PROPERTY GROUP  
LEVEL 4, 17 RANDLE STREET  
SURRY HILLS, NSW, 2010

**Woolacotts**  
CONSULTING ENGINEERS  
T +61 2 8203 1500 | www.woolacotts.com.au  
Ground Floor, 12a Brown Street, Chatswood, NSW 2067  
This drawing is copyright and must not be used, reproduced or copied wholly or in part without written permission of Woolacotts Consulting Engineers Pty Ltd.

PROPOSED RESIDENTIAL DEVELOPMENT  
307 SYDNEY ROAD AND 12 BOYLE STREET  
BALGOWLAH, NSW 2093

Scale @ A1  
1:200, 20

Job number  
18-11

Drawing number  
SW3

Date	Approved	Verified	Prepared
FEBRUARY 2018	SETB	AP	SC
Scale @ A1 1:200, 20	25.01.19	25.01.19	16.01.19
Job number	Drawing number	Amendment	
18-11	SW3	A	