

# CIVIL WORKS DRAWINGS FOR 1-7 GLADYS AVENUE, FRENCHS FOREST NSW 2086



SITE OF WORK

**LOCALITY PLAN**  
NTS

## GENERAL NOTES.

- GUTTER CROSSING AND KERB WORKS, DRIVEWAY AND FOOTPATH WORKS TO BE DONE IN ACCORDANCE WITH NORTHERN BEACHES COUNCIL DEVELOPMENT ENGINEERING STANDARD UNLESS OTHERWISE NOTED.
- ALL EROSION AND SEDIMENTATION CONTROL MEASURES ARE TO BE CARRIED OUT IN ACCORDANCE WITH COUNCIL'S CODE OF PRACTICE FOR EROSION AND SEDIMENTATION, AND MUST BE IMPLEMENTED PRIOR TO THE COMMENCEMENT OF ANY BUILDING OF CIVIL WORKS. THE DEVELOPER IS RESPONSIBLE FOR ONGOING MAINTENANCE OF EROSION AND SILTATION CONTROL MEASURES.
- ALL PUBLIC UTILITIES ARE TO BE CLEARLY IDENTIFIED IN THE FIELD PRIOR TO ANY CIVIL WORKS. COUNCIL ACCEPTS NO RESPONSIBILITY FOR DAMAGE OR RELOCATION COSTS TO UTILITIES DURING CONSTRUCTION. NORTHERN BEACHES COUNCIL IS TO BE NOTIFIED PRIOR TO THE COMMENCEMENT OF ANY WORKS.
- IT IS THE CONTRACTOR'S RESPONSIBILITY TO ENSURE THAT ALL WORKS ARE CARRIED OUT IN ACCORDANCE WITH THE OCCUPATIONAL HEALTH AND SAFETY ACT 2000.
- PERMISSION TO ENTER, CONSTRUCT WORKS AND DISCHARGE STORMWATER ONTO ADJOINING PROPERTIES IS TO BE OBTAINED AND SUBMITTED TO COUNCIL PRIOR TO COMMENCEMENT OF ANY WORKS.
- ALL RECTIFICATION WORK ARISING FROM INSUFFICIENT INFORMATION BEING SHOWN ON THE SUBMITTED PLANS IS TO BE CARRIED OUT TO THE ENGINEER'S SATISFACTION.
- ALL THE DISTURBED AREAS TO BE SHAPED AND TURFED, SHALL BE 75mm TOP SOIL OF APPROVED LOAM & TURFED.
- RETAINED TREES TO BE FENCED WITH A 1.8m HIGH CHAINWIRE LINK FENCE FULLY SUPPORTED AT GRADE TO MINIMISE THE DISTURBANCE TO EXIST. GROUND CONDITIONS WITHIN THE CANOPY DRIP LINE, "TREE PROTECTION ZONE" SIGNAGE TO BE ATTACHED TO PROTECTIVE FENCING.
- A VEHICLE CROSSING APPLICATION SHALL BE SUBMITTED TO AND APPROVED BY COUNCIL PRIOR TO COMMENCEMENT OF WORK.
- A ROAD-OPENING PERMIT SHALL BE OBTAINED FOR WORKS IN THE ROAD RESERVE PRIOR TO COMMENCEMENT OF WORK IN THE ROAD RESERVE.
- ALL SERVICES (INCLUDING PITS & LIDS) SHALL BE ADJUSTED TO SUIT DESIGN FOOTPATH LEVELS. ALL SERVICES LIDS ON THE FOOTPATH PAVEMENT TO BE REPLACED WITH INFILL PAVER TYPE TO MATCH PROPOSED PAVEMENT FINISH.

## DRAWING SCHEDULE

DRAWING No.	DRAWING TITLE
C00	COVER SHEET, LOCALITY PLAN & DRAWING SCHEDULE
C01	CIVIL WORKS LAYOUT PLAN, TYPICAL SECTIONS AND DETAILS
C03	DRIVEWAY LONG SECTIONS SHEET 1
C04	DRIVEWAY LONG SECTIONS SHEET 2
C10	TYPICAL DETAILS



A No.	ISSUED FOR D.A. Description	Date	Issued by	Checked by
A	ISSUED FOR D.A.	13.02.23	J.E.	K.E.

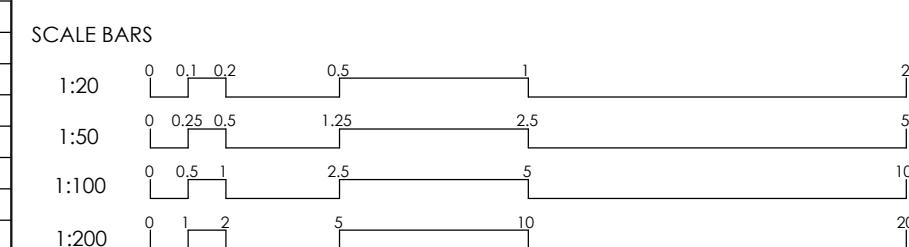

CLIENT: -  
ARCHITECT: WALSH ARCHITECTS



SUIT 2.04, L2, BLDG 3,  
35 WATERLOO RD., MACQUARIE PARK, NSW, 2113  
info@smartstructs.com.au | www.smartstructs.com.au

DRAWING TITLE			PROJECT	
<b>COVER SHEET, LOCALITY PLAN &amp; DRAWING SCHEDULE</b>			<b>1, 5 &amp; 7 GLADYS AVENUE, FRENCHS FOREST NSW 2086</b>	
SHEET NO. <b>C00</b>	REV. <b>A</b>	SCALE @ A1 <b>NTS</b>	NORTH	PROJECT NO. <b>230023</b>
DESIGNED: <b>K.E.</b>	DRAWN: <b>J.E.</b>	AUTHORISED: <b>K.E.</b>		PROJECT START DATE: <b>FEBRUARY 2023</b>



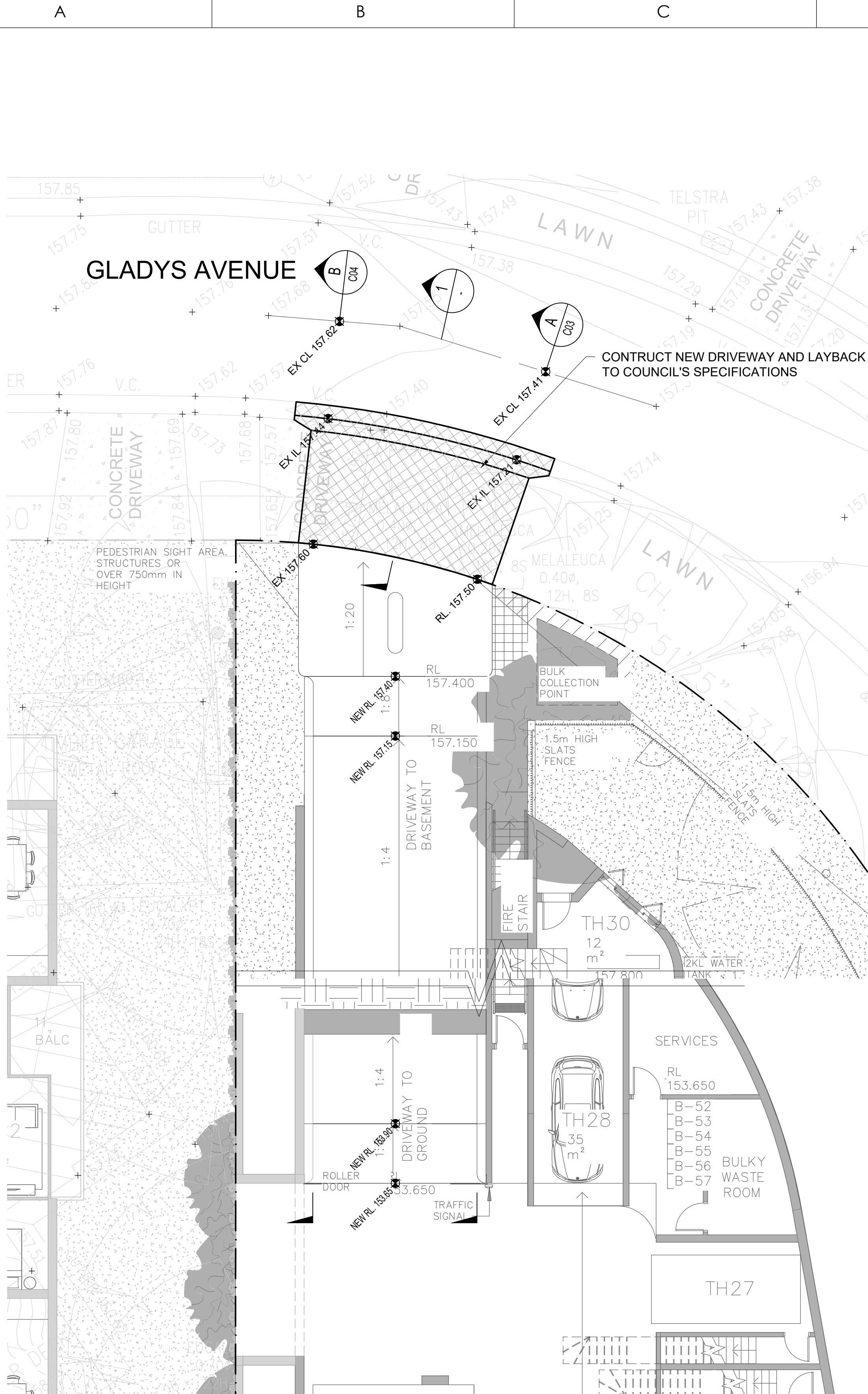

**CIVIL LAYOUT PLAN**

SCALE 1:100

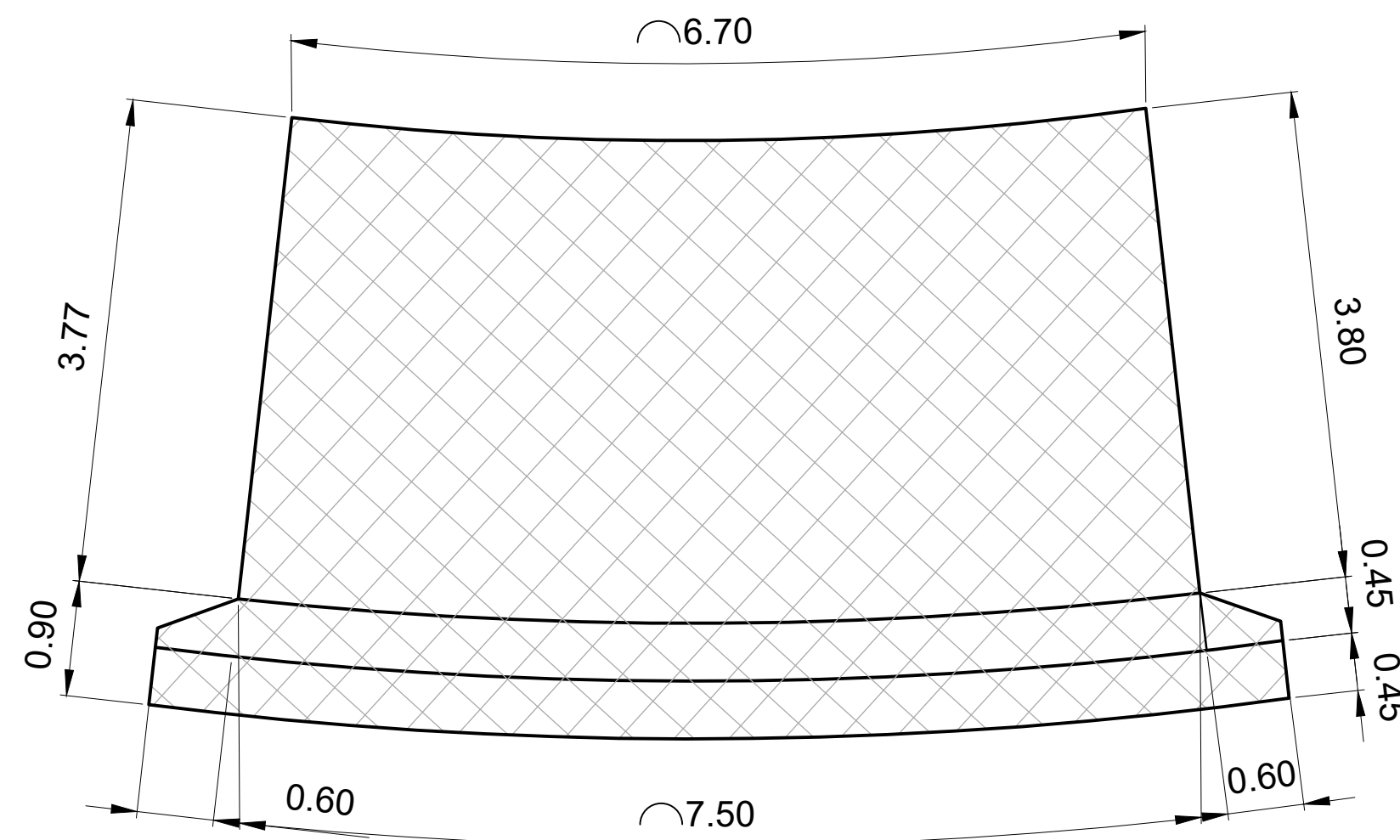

**DRIVEWAY INSET PLAN**

SCALE:1:50

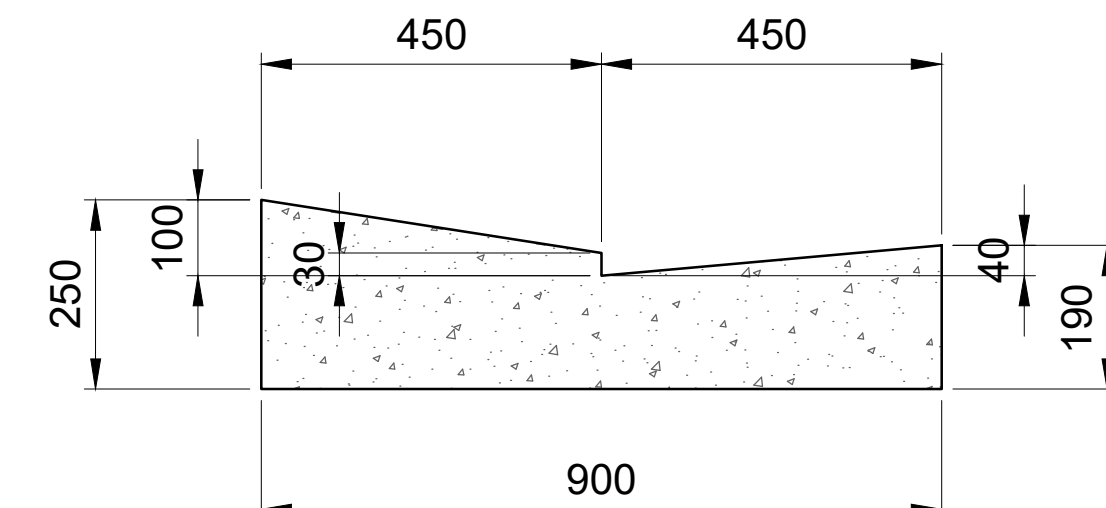

**CONCRETE LAYBACK DETAIL**

SCALE:NTS

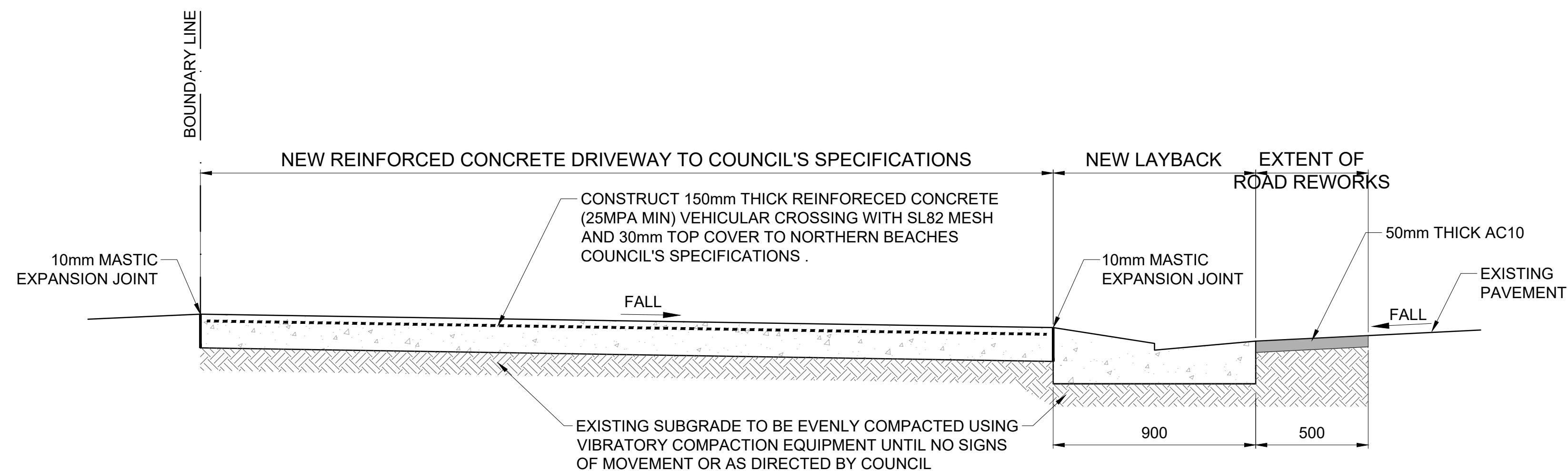

**TYPICAL SECTION THRU VEHICULAR CROSSING**

SCALE NTS

1  
-

No.	Description	Date	Issued by	Checked by
B	ISSUED FOR D.A.	21.02.23	J.E.	K.E.
A	ISSUED FOR D.A.	13.02.23	J.E.	K.E.

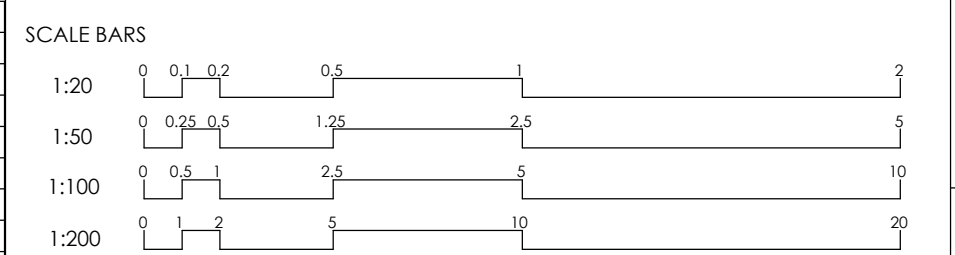

CLIENT:  
-

ARCHITECT:  
WALSH ARCHITECTS

**SMART STRUCTURES AUSTRALIA**

SUIT 2.04, L2, BLDG 3,  
35 WATERLOO RD., MACQUARIE PARK, NSW, 2113  
info@smartstructs.com.au | www.smartstructs.com.au

DRAWING TITLE			PROJECT	
<b>CIVIL WORKS LAYOUT PLAN, TYPICAL SECTIONS AND DETAILS</b>			<b>1, 5 &amp; 7 GLADYS AVENUE, FRENCHS FOREST NSW 2086</b>	
SHEET NO. <b>C01</b>	REV. <b>B</b>	SCALE @ A1 <b>AS SHOWN</b>	PROJECT NO. <b>230023</b>	
DESIGNED: K.E.	DRAWN: J.E.	AUTHORISED: K.E.	PROJECT START DATE: <b>FEBRUARY 2023</b>	

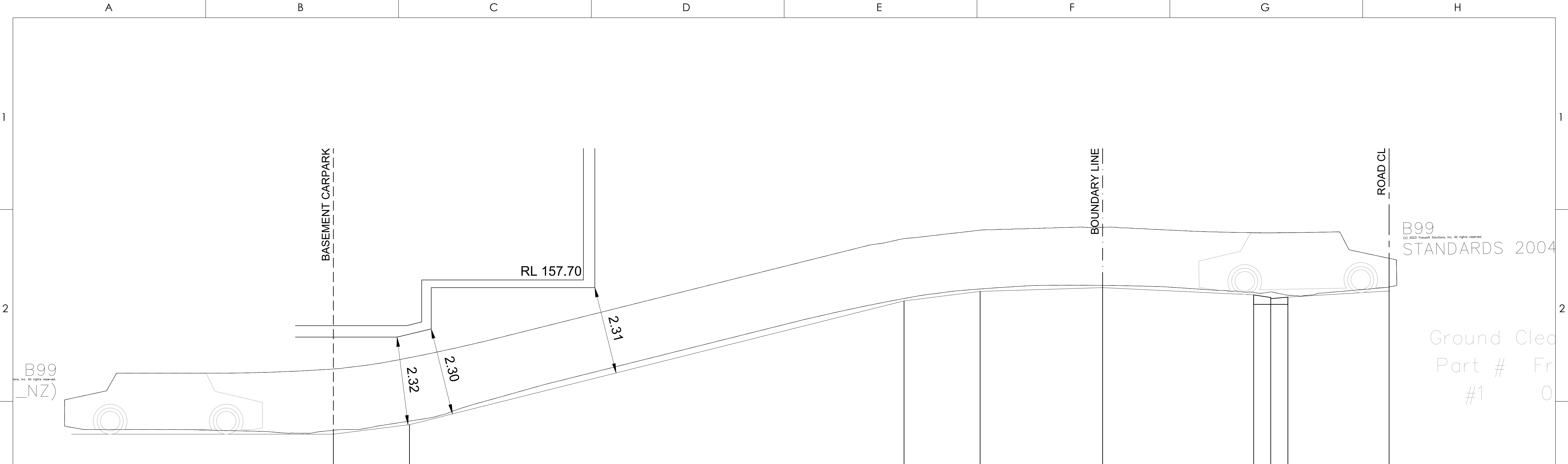

DATUM 152.00												
SLOPE		-12.50%		-25.00%		-12.50%		-3.11%		5.04%		
DESIGN LEVEL		153.65	153.90		157.15	157.40		157.50	157.31			
EX. LEVEL								157.50	157.21	157.41		
CHAINAGE		-20.22	-18.22		-5.22	-3.22		0.00	3.77	4.22	4.67	7.33

**DRIVEWAY LONG SECTION - A**  
SCALE NTS

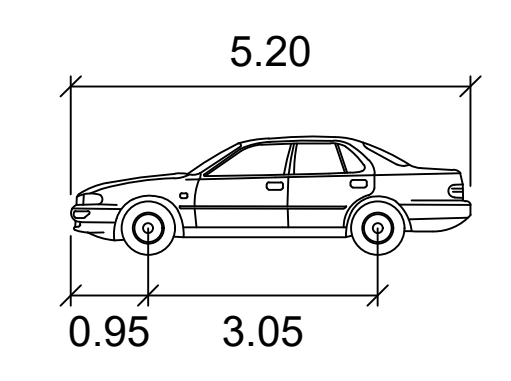

**B99** meters  
 Width : 1.94  
 Track : 1.84  
 Lock to Lock Time : 6.0  
 Steering Angle : 33.9

No.	Description	Date	Issued by	Checked by
B	ISSUED FOR D.A.	21.02.23	J.E.	K.E.
A	ISSUED FOR D.A.	13.02.23	J.E.	K.E.

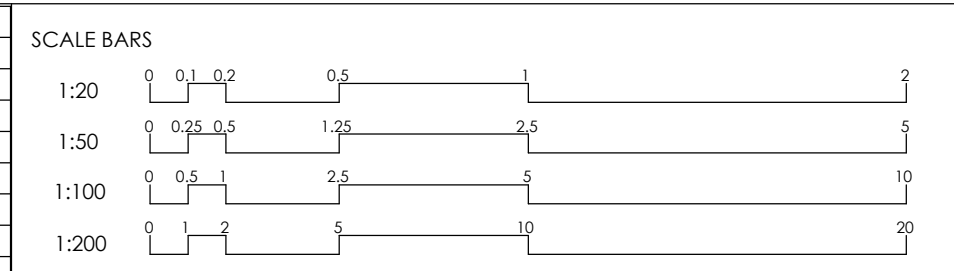

CLIENT: -  
 ARCHITECT: WALSH ARCHITECTS

**SMART STRUCTURES AUSTRALIA**  
 SUIT 2.04, L2, BLDG 3,  
 35 WATERLOO RD., MACQUARIE PARK, NSW, 2113  
 info@smartstructs.com.au | www.smartstructs.com.au

DRAWING TITLE <b>DRIVEWAY LONG SECTIONS SHEET 1</b>			PROJECT <b>1, 5 &amp; 7 GLADYS AVENUE, FRENCHS FOREST NSW 2086</b>	
SHEET NO. <b>C03</b>	REV. <b>B</b>	SCALE @ A1 <b>AS SHOWN</b>	NORTH	PROJECT NO. <b>230023</b>
DESIGNED: <b>K.E.</b>	DRAWN: <b>J.E.</b>	AUTHORISED: <b>K.E.</b>		PROJECT START DATE: <b>FEBRUARY 2023</b>



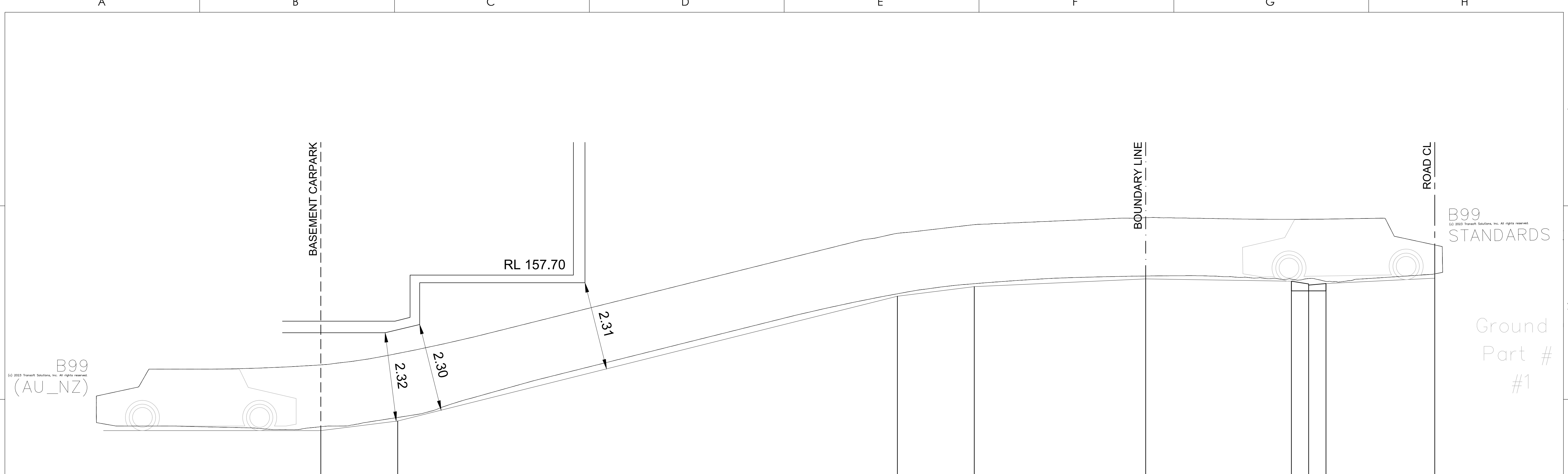

DATUM 152.00											
SLOPE		-12.50%		-25.00%		-12.50%		-4.48%		1.59%	
DESIGN LEVEL	153.65	153.90		157.15	157.40	157.60		157.54			
EX. LEVEL						157.60		157.44	157.48		157.62
CHAINAGE	-21.46	-19.46		-6.46	-4.46	0.00		3.79	4.24	4.69	7.52

**DRIVEWAY LONG SECTION - B**  
SCALE NTS

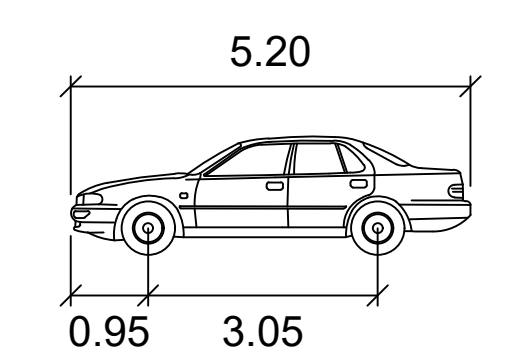

**B99** meters  
 Width : 1.94  
 Track : 1.84  
 Lock to Lock Time : 6.0  
 Steering Angle : 33.9

No.	Description	Date	Issued by	Checked by
B	ISSUED FOR D.A.	21.02.23	J.E.	K.E.
A	ISSUED FOR D.A.	13.02.23	J.E.	K.E.

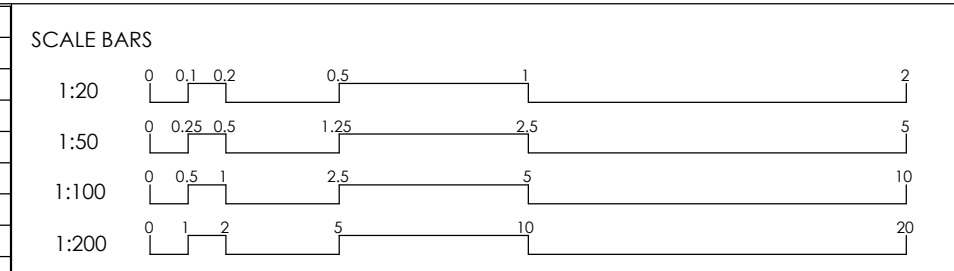

CLIENT: -  
 ARCHITECT: WALSH ARCHITECTS

**SMART STRUCTURES AUSTRALIA**  
 SUIT 2.04, L2, BLDG 3,  
 35 WATERLOO RD., MACQUARIE PARK, NSW, 2113  
 info@smartstructs.com.au | www.smartstructs.com.au

DRAWING TITLE <b>DRIVEWAY LONG SECTIONS SHEET 2</b>			PROJECT 1, 5 & 7 GLADYS AVENUE, FRENCHS FOREST NSW 2086	
SHEET NO. <b>C04</b>	REV. <b>B</b>	SCALE @ A1 <b>AS SHOWN</b>	NORTH	PROJECT NO. <b>230023</b>
DESIGNED: K.E.	DRAWN: J.E.	AUTHORISED: K.E.	PROJECT START DATE: <b>FEBRUARY 2023</b>	



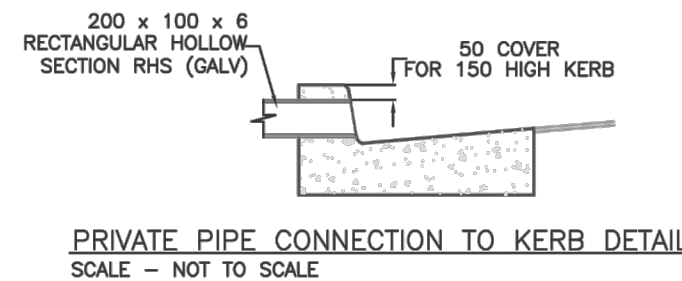
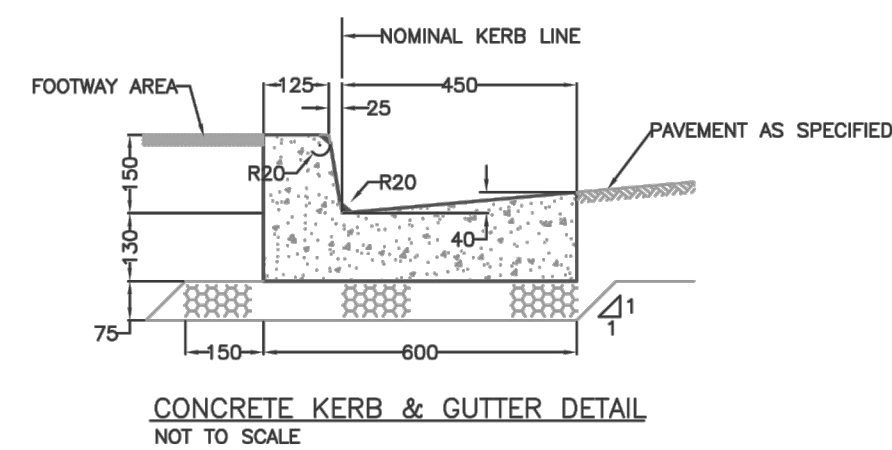
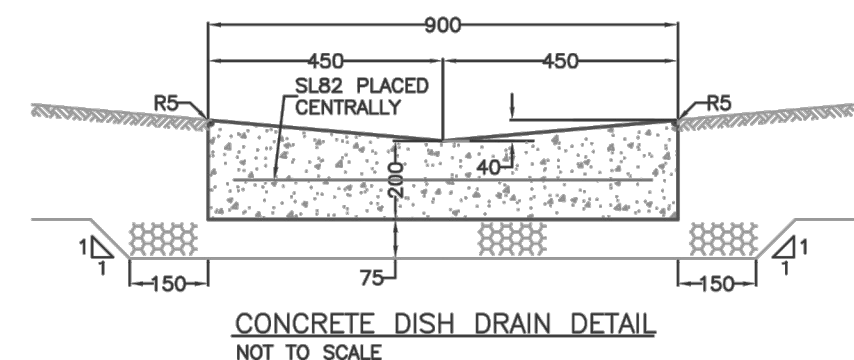
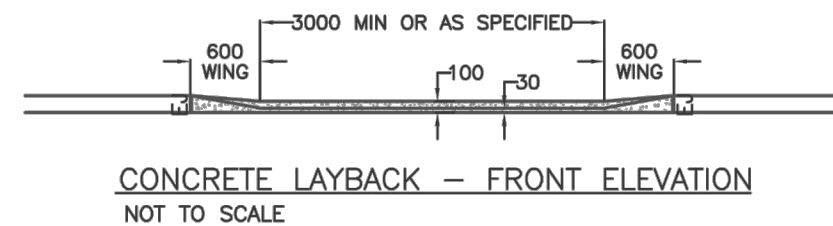
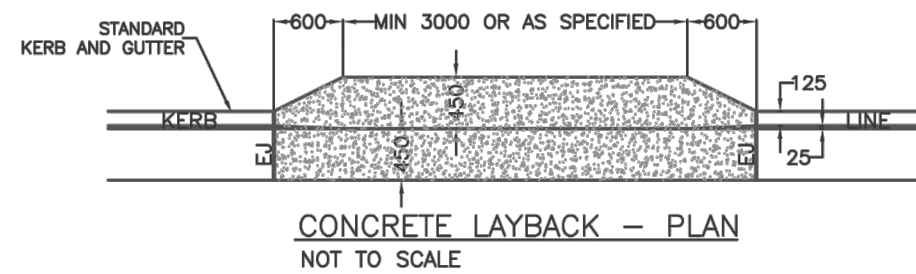
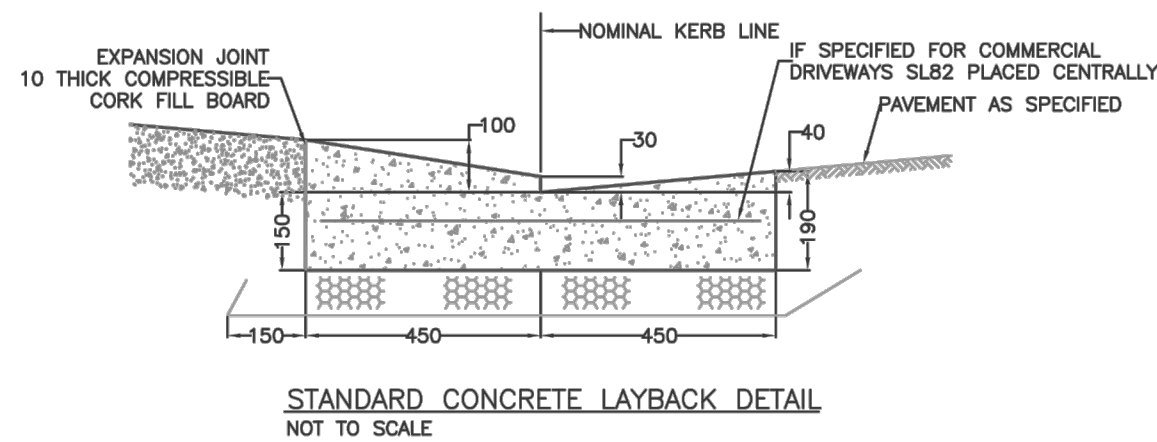

**STANDARD KERB AND GUTTER NOTES**

- KERB AND GUTTER, CONCRETE EDGING, DISH DRAINS AND THE LIKE SHALL BE POURED IN PLAIN CONCRETE AND FINISHED WITH A STEEL TROWEL.
- THE MINIMUM COMPRESSIVE STRENGTH SHALL BE 25MPa AT 28 DAYS.
- FOR ELEMENTS CONSTRUCTED USING SLIPFORM, REINFORCEMENT WILL NOT BE REQUIRED PROVIDED THAT THE CONCRETE COMPRESSIVE STRENGTH IS NOT LESS THAN 32MPa AT 28 DAYS.
- WHERE COUNCIL OR ITS REPRESENTATIVE DIRECTS THAT THE GUTTER IS TO BE RETAINED, THE CONTRACTOR SHALL PLACE A 75mm DEEP SAW CUT IN THE GUTTER INVERT AND REMOVE THE KERB AND OR LAYBACK.
- WHERE EXISTING KERB AND ASSOCIATED ELEMENT IS TO BE REPLACED SAW CUT IN THE ASPHALT MINIMUM 500mm FROM LIP OF GUTTER, COMPACT SUBGRADE AND INSTALL ASPHALT STRIP TO MAKE SMOOTH TRANSITION.
- THE CONSTRUCTION OF ALL VEHICLE CROSSINGS AND ASSOCIATED WORKS WITHIN THE ROAD RESERVE MUST BE UNDERTAKEN BY A COUNCIL APPROVED CONTRACTOR.

**STANDARD DRAWINGS**  
CONCRETE KERB DETAILS AND NOTES  
CONCRETE DISH DRAIN AND LAYBACK DETAILS & NOTES

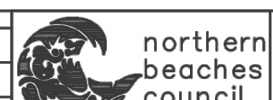

DRAWING NO. 3 REVISION 1

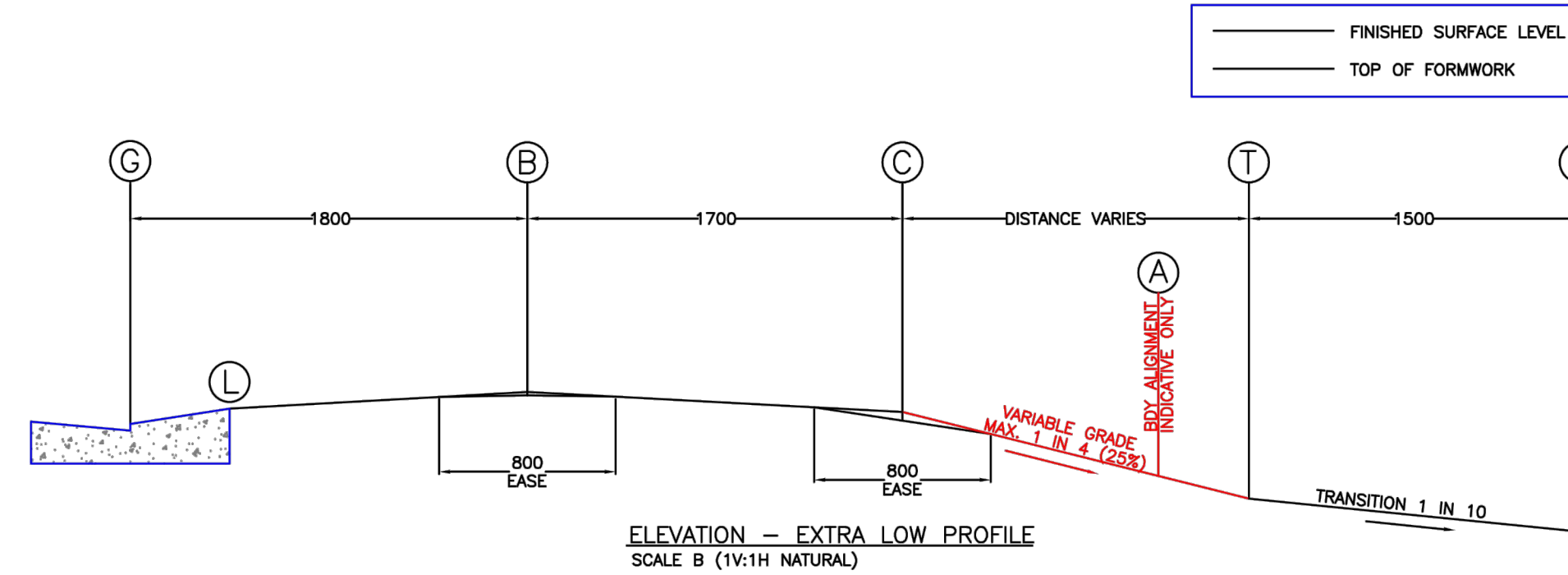

**DRIVEWAY SET-OUT SCHEDULE**

POINT	REMARK	LEVELS
G	GUTTER INVERT	DRIVEWAY CROSSING SET-OUT POINT
L	REAR OF LAYBACK	100mm ABOVE GUTTER INVERT (MAY BE ALTERED AT COUNCIL'S DISCRETION)
B	1800mm FROM GUTTER INVERT	175mm ABOVE GUTTER INVERT TO TOP OF FORMWORK
C	3500mm FROM GUTTER INVERT	FINISHED LEVEL TO BE 150mm BELOW FORMWORK BY USE OF AN 800mm EASE CENTRALISED ABOUT POINT B
A	BOUNDARY ALIGNMENT	FINISHED LEVEL TO BE 40mm BELOW FORMWORK BY USE OF AN 800mm EASE CENTRALISED ABOUT POINT C
T	1500mm BEFORE PARKING FACILITY	PLACE 10mm EXPANSION JOINT, CONTINUE CROSSING GRADIENT BETWEEN POINTS C AND T
P	PARKING FACILITY	PROVIDE TRANSITIONAL SLOPE 1V:10H OVER 1500mm WHICH MAY BE PARTIALLY OR WHOLLY ON ROAD RESERVE
		MAXIMUM GRADE PARALLEL TO ANGLE OF PARKING 1V:20H, FOR ANY OTHER DIRECTION 1V:10H

**CONCRETE DRIVEWAY NOTES**

- LAYBACK AND GUTTER SHALL BE CONSTRUCTED IN PLAIN CONCRETE AND FINISHED WITH A STEEL TROWEL.
- THE MINIMUM COMPRESSIVE STRENGTH FOR DRIVEWAYS SHALL BE 25MPa AT 28 DAYS. FOR COMMERCIAL OR INDUSTRIAL DRIVEWAYS THE SLAB DEPTH SHALL BE INCREASED TO MINIMUM OF 150mm WITH SL82 STEEL MESH AND TOP COVER OF 30mm.
- THE SUBGRADE SHALL BE EVENLY COMPACTED USING A VIBRATORY COMPACTOR EQUIPMENT UNTIL IT SHOWS NO SIGNS OF MOVEMENT, OR AS DIRECTED BY COUNCIL.
- ALL VEHICLE CROSSINGS SHALL BE CONSTRUCTED IN ACCORDANCE WITH LEVELS AND SPECIFICATION ISSUED BY COUNCIL AND MUST COMPLY WITH AS/NZS 2980:1:2004 "OFF STREET CAR PARKING" CODE.
- ALL KERBSING SHALL BE CONSTRUCTED IN ACCORDANCE WITH STANDARD DRAWINGS AND SPECIFICATION ISSUED BY COUNCIL.
- WHERE COUNCIL OR ITS REPRESENTATIVE DIRECTS THAT THE GUTTER IS TO BE RETAINED, THE CONTRACTOR IS TO PLACE A 75mm DEEP SAW CUT IN THE GUTTER INVERT AND REMOVE THE KERB AND/OR LAYBACK.
- WHERE COUNCIL OR ITS REPRESENTATIVE DIRECTS THAT THE GUTTER IS TO BE REMOVED, A ROAD OPENING PERMIT OR APPLICATION IS TO BE OBTAINED PRIOR TO COMMENCEMENT OF WORKS.
- THE CONSTRUCTION OF ALL VEHICLE CROSSINGS AND ASSOCIATED WORKS MUST BE PERFORMED BY A COUNCIL APPROVED CONTRACTOR.
- SARICUT 50mm ASPHALT STRIP AND MATCH IN LAYBACK WITH ROAD SURFACE TO SMOOTH TRANSITION.

**VEHICLE CROSSING CONSTRUCTION NOTES**

- AT LEAST 48 HOURS' NOTICE OF INTENTION SHALL BE GIVEN TO COUNCIL ENGINEER TO POUR CONCRETE WITHIN THE ROAD RESERVE AND NO CONCRETE SHALL BE PLACED UNTIL THE FORMWORK HAS BEEN APPROVED AND AN INSPECTION NOTICE ISSUED.
- ALL DISTURBED AREAS OF THE FOOTWAY ADJACENT TO THE VEHICLE CROSSING SHALL BE TURFED AND FINISHED LEVEL WITH THE CONCRETE SURFACE. RAISED EDGES ARE UNACCEPTABLE.
- THE ROAD ADJOINING THE VEHICLE CROSSING SHALL BE BATTERED AND TURFED AT A MAXIMUM GRADIENT OF 1V:5H OR AS DIRECTED BY COUNCIL.
- CONCRETE FOOTPATH ADJUSTMENTS SHALL BE IN ACCORDANCE WITH COUNCIL'S SPECIFICATION AND SATISFACTION.
- THE SUBGRADE MUST BE THOROUGHLY COMPACTED BY THE USE OF VIBRATORY COMPACTOR EQUIPMENT UNTIL IT SHOWS NO SIGNS OF MOVEMENT, OR AS DIRECTED BY COUNCIL.
- VEHICLE CROSSING SLABS MUST BE POURED IN PLAIN CONCRETE. SLAB SURFACE MUST BE COVE FINISHED (OR EQUIVALENT) AND EDGES TO BE FINISHED WITH A 50mm MARGIN.
- ALL CHANGES IN GRADE SHALL BE SCREEDED TO ENSURE NO RIDG/SHARP TRANSITIONS.
- THE MINIMUM COMPRESSIVE STRENGTH OF CONCRETE SHALL BE 25MPa AT 28 DAYS.
- THE MINIMUM THICKNESS OF CONCRETE SHALL BE AS FOLLOWS:  
(a) SINGLE RESIDENTIAL DWELLING: 150mm THICK REINFORCED WITH SL72 MESH PLACED 30mm BELOW TOP OF CONCRETE SLAB  
(b) MULTI-UNIT RESIDENTIAL: 150mm THICK REINFORCED WITH SL82 MESH PLACED 30mm BELOW TOP OF CONCRETE SLAB  
(c) COMMERCIAL OR INDUSTRIAL: 180mm THICK REINFORCED WITH SL82 MESH PLACED 30mm BELOW TOP OF CONCRETE SLAB
- THE VEHICLE CROSSING UP TO 2400mm FROM THE GUTTER INVERT SHALL BE GRADED PARALLEL WITH THE ROAD CENTRELINE.
- THE VEHICLE CROSSING SHALL BE CONSTRUCTED PERPENDICULAR TO THE ROAD PAVEMENT UNLESS OTHERWISE INSTRUCTED BY COUNCIL.
- THE CONSTRUCTION OF ALL VEHICLE CROSSINGS AND ASSOCIATED WORKS ON THE ROAD RESERVE MUST BE COMPLETED BY A COUNCIL APPROVED CONTRACTOR.
- NO TREE ROOTS GREATER THAN 50mm IN DIAMETER ARE TO BE REMOVED UNLESS AUTHORISED BY A QUALIFIED ARBORIST.
- ANY ROOTS APPROVED FOR REMOVAL SHALL BE CLEAN CUT WITH SHARP TOOLS SUCH AS SECATORS, PRUNERS, HANDSAWS, CHAINSAWS OR SPECIALISED ROOT PRUNING EQUIPMENT.

**IMPORTANT DRIVEWAY DESIGN NOTES:**

- THE STANDARD DRIVEWAY PROFILES SHOWN MAY NOT SUIT ALL TERRAIN CONDITIONS.
- THESE STANDARD DRIVEWAY PROFILES MAY NEED TO BE MODIFIED TO SUIT.
- WHERE THE STANDARD DRIVEWAY PROFILES SHOWN MAY NOT TAKE INTO CONSIDERATION CONNECTING FOOTPATHS WHERE THE FOOTPATH MEETS THE DRIVEWAY, FOR DISABLED ACCESSIBILITY, A SECTION OF THE DRIVEWAY MAY NEED TO BE DESIGNED WITH A MAXIMUM 2.5% CROSS-FALL GRADED TOWARDS THE KERB OR ROAD SIDE. ALSO THE STANDARD DRIVEWAY PROFILES SHOWN HAS NOT BEEN DESIGNED TO ACCOMMODATE ANY SPECIAL NEEDS, FOR EXAMPLE, IN A FLOOD PLANNING AREA WHERE A MINIMUM FREE BOARD CREST IS REQUIRED TO PROTECT THE PARKING FACILITY.
- WHERE MODIFICATION OF THE DRIVEWAY IS REQUIRED TO MEET EXISTING OR PROPOSED CROSS FALLS OR LEVELS, THE FINAL DESIGN PROFILE MUST BE CHECKED AGAINST THE AUSTRALIAN STANDARD AS/NZS 2980:1:2004 "OFF STREET CAR PARKING" CODE FOR SCRAPING AND BOT TOMING USING THE 85TH PERCENTILE PASSENGER VEHICLE.
- THE DESIGNER WILL NEED TO LIAISE WITH COUNCIL TO DEVELOP A SUITABLE DESIGN SOLUTION.

LEVEL	DRAWN	CHK	DATE
1:20	THOMAS LAU	T.L.	07/07/2022
1:50	THOMAS LAU	T.L.	20/02/23
1:100	THOMAS LAU	T.L.	20/02/23
1:200	THOMAS LAU	T.L.	20/02/23

DESIGN APPROVED	APPROVED FOR CONSTRUCTION
THOMAS LAU DATE: 20/02/23	THOMAS LAU DATE: 20/02/23
STEVE WATSON DATE: 20/02/23	THOMAS LAU DATE: 20/02/23
STEVE WATSON DATE: 20/02/23	THOMAS LAU DATE: 20/02/23

SCALE	UNIT
0 0.5 1.0 1.5 2.0 2.5	METRES 1:20 @ A3
0 0.2 0.4 0.6 0.8 1.0	METRES 1:50 @ A3
0 0.5 1.0 1.5 2.0 2.5	METRES 1:100 @ A3
0 0.5 1.0 1.5 2.0 2.5	METRES 1:200 @ A3

LEVEL	DRAWN	CHK	DATE
1:20	THOMAS LAU	T.L.	07/07/2022
1:50	THOMAS LAU	T.L.	20/02/23
1:100	THOMAS LAU	T.L.	20/02/23
1:200	THOMAS LAU	T.L.	20/02/23

DESIGN APPROVED	APPROVED FOR CONSTRUCTION
THOMAS LAU DATE: 20/02/23	THOMAS LAU DATE: 20/02/23
STEVE WATSON DATE: 20/02/23	THOMAS LAU DATE: 20/02/23
STEVE WATSON DATE: 20/02/23	THOMAS LAU DATE: 20/02/23

SCALE	UNIT
0 0.5 1.0 1.5 2.0 2.5	METRES 1:20 @ A3
0 0.2 0.4 0.6 0.8 1.0	METRES 1:50 @ A3
0 0.5 1.0 1.5 2.0 2.5	METRES 1:100 @ A3
0 0.5 1.0 1.5 2.0 2.5	METRES 1:200 @ A3

LEVEL	DRAWN	CHK	DATE
1:20	THOMAS LAU	T.L.	07/07/2022
1:50	THOMAS LAU	T.L.	20/02/23
1:100	THOMAS LAU	T.L.	20/02/23
1:200	THOMAS LAU	T.L.	20/02/23

DESIGN APPROVED	APPROVED FOR CONSTRUCTION
THOMAS LAU DATE: 20/02/23	THOMAS LAU DATE: 20/02/23
STEVE WATSON DATE: 20/02/23	THOMAS LAU DATE: 20/02/23
STEVE WATSON DATE: 20/02/23	THOMAS LAU DATE: 20/02/23

SCALE	UNIT
0 0.5 1.0 1.5 2.0 2.5	METRES 1:20 @ A3
0 0.2 0.4 0.6 0.8 1.0	METRES 1:50 @ A3
0 0.5 1.0 1.5 2.0 2.5	METRES 1:100 @ A3
0 0.5 1.0 1.5 2.0 2.5	METRES 1:200 @ A3

LEVEL	DRAWN	CHK	DATE
1:20	THOMAS LAU	T.L.	07/07/2022
1:50	THOMAS LAU	T.L.	20/02/23
1:100	THOMAS LAU	T.L.	20/02/23
1:200	THOMAS LAU	T.L.	20/02/23

DESIGN APPROVED	APPROVED FOR CONSTRUCTION
THOMAS LAU DATE: 20/02/23	THOMAS LAU DATE: 20/02/23
STEVE WATSON DATE: 20/02/23	THOMAS LAU DATE: 20/02/23
STEVE WATSON DATE: 20/02/23	THOMAS LAU DATE: 20/02/23

SCALE	UNIT
0 0.5 1.0 1.5 2.0 2.5	METRES 1:20 @ A3
0 0.2 0.4 0.6 0.8 1.0	METRES 1:50 @ A3
0 0.5 1.0 1.5 2.0 2.5	METRES 1:100 @ A3
0 0.5 1.0 1.5 2.0 2.5	METRES 1:200 @ A3

LEVEL	DRAWN	CHK	DATE
1:20	THOMAS LAU	T.L.	07/07/2022
1:50	THOMAS LAU	T.L.	20/02/23
1:100	THOMAS LAU	T.L.	20/02/23
1:200	THOMAS LAU	T.L.	20/02/23

DESIGN APPROVED	APPROVED FOR CONSTRUCTION
THOMAS LAU DATE: 20/02/23	THOMAS LAU DATE: 20/02/23
STEVE WATSON DATE: 20/02/23	THOMAS LAU DATE: 20/02/23
STEVE WATSON DATE: 20/02/23	THOMAS LAU DATE: 20/02/23

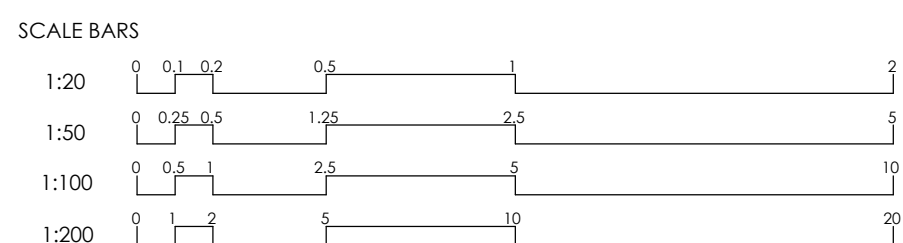

CLIENT:

ARCHITECT:  
**WALSH ARCHITECTS**



SUIT 2.04, L2, BLDG 3,  
35 WATERLOO RD., MACQUARIE PARK, NSW, 2113  
info@smartstrucs.com.au | www.smartstrucs.com.au

DRAWING TITLE  
**TYPICAL DETAILS**

SHEET NO.	REV.	SCALE @ A1
C10	A	NTS
DESIGNED: K.E.	DRAWN: J.E.	AUTHORISED: K.E.

PROJECT  
1, 5 & 7 GLADYS AVENUE,  
FRENCHS FOREST NSW 2086

PROJECT NO.	PROJECT START DATE:
230023	FEBRUARY 2023

No.	ISSUED FOR D.A.	Description	Date	Issued by	Checked by
A	ISSUED FOR D.A.		13.02.23	J.E.	K.E.