

# PROPOSED DEVELOPMENT

## 638 PITTWATER ROAD, BROOKVALE

### STORMWATER PLANS

#### GENERAL NOTES

- G1. THE DRAWINGS SHALL BE READ IN CONJUNCTION WITH ALL ARCHITECTURAL DRAWINGS AND SPECIFICATIONS AND OTHER WRITTEN INSTRUCTIONS THAT MAY BE ISSUED.
- G2. DIMENSIONS SHALL NOT BE OBTAINED BY SCALING FROM THE DRAWINGS. REFER ARCHITECTS DRAWINGS FOR ALL DIMENSIONS.
- G3. REFER ANY DISCREPANCY TO THE ENGINEER/ARCHITECT.
- G4. MATERIALS AND WORKMANSHIP SHALL COMPLY WITH THE APPROPRIATE SAA SPECIFICATIONS OR CODE AND WITH THE REQUIREMENTS OF THE RELEVANT LOCAL AUTHORITY.
- G5. THE ALIGNMENT AND LEVEL OF ALL SERVICES SHOWN ARE APPROXIMATE ONLY. THE CONTRACTOR SHALL CONFIRM THE POSITION AND LEVEL OF ALL SERVICES PRIOR TO COMMENCEMENT OF CONSTRUCTION. ANY DAMAGE TO SERVICES SHALL BE RECTIFIED AT THE CONTRACTORS EXPENSE.
- G6. NO WORKS ARE TO COMMENCE UNTIL THE REQUIRED TREE REMOVAL PERMITS HAVE BEEN GRANTED BY RELEVANT LOCAL AUTHORITY, AND THE APPROPRIATE NOTICE OF INTENTION TO COMMENCE GIVEN.
- G7. ALL SERVICES, OR CONDUITS FOR SERVICING SHALL BE INSTALLED PRIOR TO COMMENCEMENT OF PAVEMENT CONSTRUCTION.
- G8. SUBSOIL DRAINAGE, COMPRISING 100 AGRICULTURE PIPE IN GEO-STOCKING TO BE PLACED AS SHOWN AND AS MAY BE DIRECTED BY THE SUPERINTENDENT. SUBSOIL DRAINAGE SHALL BE CONSTRUCTED IN ACCORDANCE WITH THE RELEVANT LOCAL AUTHORITY CONSTRUCTION SPECIFICATION.
- G9. NO WORK IS PERMITTED WITHIN ADJOINING PROPERTIES WITHOUT WRITTEN PERMISSION FROM THE OWNERS OR RESPONSIBLE AUTHORITY.

#### DRAINAGE NOTES

- D1. ALL DRAINAGE OUTLET LEVELS SHALL BE CONFIRMED ON SITE, PRIOR TO CONSTRUCTION COMMENCING.
- D2. ALL PIPES WITHIN THE PROPERTY TO BE MIN. 100 DIA UPVC @ 1% MIN. GRADE, UNO.
- D3. ALL PITS WITHIN THE PROPERTY ARE TO BE FITTED WITH "WELDLOK" OR APPROVED EQUIVALENT GRATES:  
- LIGHT DUTY FOR LANDSCAPED AREAS  
- HEAVY DUTY WHERE SUBJECT TO VEHICULAR TRAFFIC
- D4. PITS WITHIN THE PROPERTY MAY BE CONSTRUCTED AS:  
1) PRECAST STORMWATER PITS  
2) CAST INSITU MASS CONCRETE  
3) CEMENT RENDERED 230mm BRICKWORK  
SUBJECT TO THE RELEVANT LOCAL AUTHORITY CONSTRUCTION SPECIFICATION.
- D5. ENSURE ALL GRATES TO PITS ARE SET BELOW FINISHED SURFACE LEVEL WITHIN THE PROPERTY. TOP OF PIT R.L.'S ARE APPROXIMATE ONLY AND MAY BE VARIED SUBJECT TO APPROVAL OF THE ENGINEER. ALL INVERT LEVELS ARE TO BE ACHIEVED.
- D6. ANY PIPES BENEATH RELEVANT LOCAL AUTHORITY ROAD TO BE RUBBER RING JOINTED RCP, UNO.
- D7. ALL PITS IN ROADWAYS ARE TO BE FITTED WITH HEAVY DUTY GRATES WITH LOCKING BOLTS AND CONTINUOUS HINGE.
- D8. PROVIDE STEP IRONS TO STORMWATER PITS GREATER THAN 1200 IN DEPTH.
- D9. TRENCH BACK FILL IN ROADWAYS SHALL COMPRISE SHARP, CLEAN GRANULAR BACK FILL IN ACCORDANCE WITH THE RELEVANT LOCAL AUTHORITY SPECIFICATION TO NON-TRAFFICABLE AREAS TO BE COMPACTED BY RODDING AND TAMPING USING A FLAT PLATE VIBRATOR.
- D10. WHERE A HIGH EARLY DISCHARGE (HED) PIT IS PROVIDED ALL PIPES ARE TO BE CONNECTED TO THE HED PIT, UNO.
- D11. DOWN PIPES SHALL BE A MINIMUM OF DN100 SW GRADE UPVC OR 100X100 COLORBOND/ZINCALUME STEEL, UNO.
- D12. COLORBOND OR ZINCALUME STEEL BOX GUTTERS SHALL BE A MINIMUM OF 450 WIDE X 150 DEEP.
- D13. EAVES GUTTERS SHALL BE A MINIMUM OF 125 WIDE X 100 DEEP (OR OF EQUIVALENT AREA) COLORBOND OR ZINCALUME STEEL, UNO.
- D14. SUBSOIL DRAINAGE SHALL BE PROVIDED TO ALL RETAINING WALLS & EMBANKMENTS, WITH THE LINES FEEDING INTO THE STORMWATER DRAINAGE SYSTEM, UNO.

#### EARTHWORKS NOTES

- E1. THE EARTHWORKS SHALL BE CARRIED OUT IN ACCORDANCE WITH THE PROJECT GEOTECHNICAL REPORT.
- E2. THE SITE OF THE WORKS SHALL BE PREPARED BY STRIPPING ALL EXISTING TOPSOIL, FILL AND VEGETATION.
- E3. SUBGRADE SHALL BE COMPACTED UNTIL A DRY DENSITY HAS BEEN ACHIEVED OF NOT LESS THAN 100% OF THE STANDARD MAXIMUM DRY DENSITY WHEN TESTED IN ACCORDANCE WITH AS 1289 TESTS E.1.1. OR E.1.2.
- E4. THE EXPOSED SUBGRADE SHOULD BE PROOF ROLLED TO DETECT ANY SOFT OR WET AREAS WHICH SHOULD BE LOCALLY EXCAVATED AND BACK FILLED WITH SELECTED MATERIAL.
- E5. THE BACK FILLING MATERIAL SHALL BE IMPORTED GRANULAR FILL OF LOW PLASTICITY, PREFERABLY CRUSHED SANDSTONE, AND TO BE PLACED IN LAYERS NOT EXCEEDING 150 LOOSE THICKNESS AND COMPACTED TO 98% OF STANDARD DRY DENSITY AT A MOISTURE CONTENT WITHIN 2% OF OPTIMUM.
- E6. SITE WORKS ARE TO BE BATTERED TO ADJACENT PROPERTY LEVELS.
- E7. STORMWATER MUST NOT BE CONCENTRATED ON TO AN ADJACENT PROPERTY.
- E8. AT NO TIME DURING OR AFTER CONSTRUCTION IS STORMWATER TO BE PONDED ON ADJOINING PROPERTIES.
- E9. THE SITE SHALL BE GRADED AND DRAINED SO THAT STORMWATER WILL BE DIRECTED AWAY FROM THE BUILDING PLATFORM.
- E10. STORMWATER DRAINAGE SHALL BE PROVIDED AND MAINTAINED THROUGHOUT THE COURSE OF CONSTRUCTION. ALL STORMWATER RUNOFF SHALL BE GRADED AWAY FROM THE SITE WORKS AND DISPOSED OF VIA SURFACE CATCHDRAINS AND STORMWATER COLLECTION PITS.
- E11. ALL SURFACE CATCH DRAINS SHALL BE GRADED AT 1% (1 IN 100) MINIMUM. THE GROUND SHALL GRADE AWAY FROM ANY DWELLING AT 5% (1 IN 20) FOR THE FIRST METRE THEN AT 2.5% (1 IN 40).
- E12. WHERE A CUT FILL PLATFORM IS USED THERE SHALL BE A MINIMUM BERM 1000 WIDE TO THE PERIMETER OF THE SITE WORKS WHICH SHALL BE SUPPORTED BY BATTERS OF 3:1 IN FILL.
- E13. ANY VERTICAL OR NEAR VERTICAL PERMANENT EXCAVATION (CUT) DEEPER THAN 600 IN MATERIAL OTHER THAN ROCK SHALL BE ADEQUATELY RETAINED OR BATTERED AT A MINIMUM OF 3:1.
- E14. WHERE BATTERS CANNOT BE PROVIDED TO SUPPORT THE CUT OR FILL, THEY SHALL BE ADEQUATELY RETAINED.
- E15. RETAINING WALLS ARE TO BE CONSTRUCTED WITH ADEQUATE SUBSOIL DRAINAGE.

#### CONCRETE PAVEMENT

- C1. SUBGRADE SHALL BE PREPARED AS OUTLINED IN EARTHWORKS.
- C2. PROVIDE JOINTING AT MINIMUM 6000 MAX. INTERVALS OR AS OTHERWISE SPECIFIED IN THE DRAWINGS.
- C3. CONCRETE SHALL COMPRISE A MIN. COMPRESSIVE STRENGTH OF 32MPa AT 28 DAYS IN ACCORDANCE WITH THE RELEVANT LOCAL AUTHORITY SPECIFICATION, UNO.
- C4. ANY SUB-BASE MATERIAL SHALL BE COMPACTED AS OUTLINED IN EARTHWORKS.
- C5. CONCRETE KERB AND GUTTER SHALL COMPRISE A MINIMUM COMPRESSIVE STRENGTH OF 25MPa, UNO.
- C6. CONCRETE WORKS ARE TO BE CURED BY ONE OF THE FOLLOWING MEANS:  
i) WETTING TWICE DAILY FOR THE FIRST THREE DAYS;  
ii) USING AN APPROVED CURING COMPOUNDED FOR A MINIMUM OF 7 DAYS COMMENCING IMMEDIATELY AFTER POURING.

#### FLEXIBLE PAVEMENT NOTES

- F1. SUBGRADE SHALL BE PREPARED AS OUTLINED IN EARTHWORKS.
- F2. PAVEMENT MATERIAL SHALL CONSIST OF APPROVED OR RIPPED SANDSTONE, NATURAL GRAVEL OR FINE CRUSH ROCK AS PER THE RELEVANT COUNCIL AUTHORITY SPECIFICATION.  
PAVEMENT MATERIALS SHALL BE SPREAD IN LAYERS NOT EXCEEDING 150 AND NOT LESS 75 COMPACTED THICKNESS.
- F3. PAVEMENT MATERIALS SHALL BE SIZED AND OF A STANDARD OUTLINED IN AS1141.
- F4. CRUSHED OR RIPPED SANDSTONE SHALL BE MINUS 75 NOMINAL SIZE DERIVED FROM SOUND, CLEAN SANDSTONE FREE FROM OVERBURDEN, CLAY SEAMS, SHALE AND OTHER DELETERIOUS MATERIAL.
- F5. PAVEMENT MATERIALS SHALL BE COMPACTED BY SUITABLE MEANS TO SATISFY THE FOLLOWING MINIMUM SPECIFICATIONS (AS PER AS1289.2)

DESCRIPTION	MEDIUM DENSITY RATIO
SUB-BASE	98% MOD
BASE COURSE	98% MOD
ASPHALTIC CONCRETE	97% MOD

AND SUBJECT TO THE RELEVANT LOCAL AUTHORITY CONSTRUCTION SPECIFICATION.
- F6. TESTING FOR EACH LAYER SHALL BE UNDERTAKEN BY A N.A.T.A. REGISTERED LABORATORY IN ACCORDANCE WITH AS1289, AT NOT MORE THAN 50m INTERVALS AND A MINIMUM OF TWO PER LAYER. FURTHER FREQUENCY OF TESTING SHALL BE NO LESS THAN THAT REQUIRED BY AS3978.

#### PAVED AREAS NOTES

- A1. SUBGRADE SHALL BE PREPARED AS OUTLINED IN EARTHWORKS.
- A2. ALL PAVERS ARE TO BE PLACED IN ACCORDANCE WITH THE MANUFACTURER'S SPECIFICATION.
- A3. TRAFFICABLE AREAS:  
SUB-BASE TO BE 150 COMPACTED THICKNESS DGS75.  
SUB-BASE TO BE SUITABLY COMPACTED TO MEDIUM DENSITY 98% MOD.  
SUB-BASE TO EXTEND AT LEAST 200 BEYOND PAVED SURFACE.  
PAVERS TO BE 80 THICK INTERLOCKING PAVERS ON 50 SAND BEDDING.
- A4. NON TRAFFICABLE AREAS:  
SUB BASE AS PER TRAFFICABLE AREAS  
PAVERS TO BE 80 INTERLOCKING PAVERS ON 50 SAND BEDDING (UNO).

#### EROSION AND SEDIMENT NOTES

- B1. THIS PLAN TO BE READ IN CONJUNCTION WITH EROSION AND SEDIMENT CONTROL DETAILS AS ATTACHED.
- B2. THE CONTRACTOR SHALL IMPLEMENT ALL SOIL EROSION AND SEDIMENT CONTROL MEASURES AS NECESSARY AND TO THE SATISFACTION OF THE RELEVANT LOCAL AUTHORITY PRIOR TO THE COMMENCEMENT OF AND DURING CONSTRUCTION. NO DISTURBANCE TO THE SITE SHALL BE PERMITTED OTHER THAN IN THE IMMEDIATE AREA OF THE WORKS AND NO MATERIAL SHALL BE REMOVED FROM THE SITE WITHOUT THE RELEVANT LOCAL AUTHORITY APPROVAL. ALL EROSION AND SEDIMENT CONTROL DEVICES TO BE INSTALLED AND MAINTAINED IN ACCORDANCE WITH STANDARDS OUTLINED IN NSW DEPARTMENT OF HOUSING'S "MANAGING URBAN STORMWATER - SOILS AND CONSTRUCTIONS".
- B3. TOPSOIL SHALL BE STRIPPED AND STOCKPILED OUTSIDE HAZARD AREAS SUCH AS DRAINAGE LINES. THIS TOPSOIL SHALL BE RESPREAD LATER ON AREAS TO BE REVEGETATED AND STABILISED ONLY, (I.E. ALL FOOTPATHS, BATTERS, SITE REGARDING AREAS, BASINS AND CATCHDRAINS). TOPSOIL SHALL NOT BE RESPREAD ON ANY OTHER AREAS UNLESS SPECIFICALLY INSTRUCTED BY THE SUPERINTENDENT. IF THEY ARE TO REMAIN FOR LONGER THAN ONE MONTH STOCKPILES SHALL BE PROTECTED FROM EROSION BY COVERING THEM WITH A MULCH AND HYDROSEEDING AND, IF NECESSARY, BY LOCATING BANKS OR DRAINS DOWNSTREAM OF A STOCKPILE TO RETARD SILT LADEN RUNOFF.
- B4. THE CONTRACTOR SHALL REGULARLY MAINTAIN ALL EROSION AND SEDIMENT CONTROL DEVICES AND REMOVE ACCUMULATED SILT FROM SUCH DEVICES SUCH THAT MORE THAN 60% OF THEIR CAPACITY IS LOST. ALL THE SILT IS TO BE PLACED OUTSIDE THE LIMIT OF WORKS. THE PERIOD FOR MAINTAINING THESE DEVICES SHALL BE AT LEAST UNTIL ALL DISTURBED AREAS ARE REVEGETATED AND FURTHER AS MAY BE DIRECTED BY THE SUPERINTENDENT OR COUNCIL.
- B5. LAY TURF STRIP (MIN 300 WIDE) ON 100 TOPSOIL BEHIND ALL KERB WITH 1000 LONG RETURNS EVERY 6000 AND AROUND STRUCTURES IMMEDIATELY AFTER BACKFILLING AS PER THE RELEVANT LOCAL AUTHORITY SPECIFICATION.
- B6. THE CONTRACTOR SHALL GRASS SEED ALL DISTURBED AREAS WITH AN APPROVED MIX AS SOON AS PRACTICABLE AFTER COMPLETION OF EARTHWORKS AND REGRADING.
- B7. VEHICULAR TRAFFIC SHALL BE CONTROLLED DURING CONSTRUCTION CONFINING ACCESS WHERE POSSIBLE TO NOMINATED STABILISED ACCESS POINTS.
- B8. WHEN ANY DEVICES ARE TO BE HANDED OVER TO COUNCIL THEY SHALL BE IN CLEAN AND STABLE CONDITION.
- B9. THE CONTRACTOR SHALL IMPLEMENT DUST CONTROL BY REGULAR WETTING DOWN (BUT NOT SATURATING) DISTURBED AREA.
- B10. PROVIDE AND MAINTAIN SILT TRAPS AROUND ALL SURFACE INLET PITS UNTIL CATCHMENT IS REVEGETATED OR PAVED.
- B11. REVEGETATE ALL TRENCHES IMMEDIATELY UPON COMPLETION OF BACKFILLING.
- B12. ALL DRAINAGE PIPE INLETS TO BE CAPPED UNTIL:  
- DOWNPIPES CONNECTED  
- PITS CONSTRUCTED AND PROTECTED WITH SILT BARRIER

#### EROSION AND SEDIMENT NOTES

MINIMUM PIPE COVER SHALL BE AS FOLLOWS

LOCATION	MINIMUM COVER
NO SUBJECT TO VEHICLE LOADING	100mm SINGLE RESIDENTAL
SUBJECT TO VEHICLE LOADING	450mm WHERE NOT IN A ROAD
UNDER A SEALED ROAD	600mm
UNSEALED ROAD	750mm
PAVED DRIVEWAY	100mm PLUS DEPTH OF CONCRETE

SEE AS2032 INSTALLATION OF UPVC PIPES FOR FURTHER INFORMATION.

CONCRETE PIPE COVER SHALL BE IN ACCORDANCE WITH AS3725-1989 LOADS ON BURIED CONCRETE PIPES, HOWEVER A MINIMUM COVER OF 450mm WILL APPLY.

WHERE INSUFFICIENT COVER IS PROVIDED, THE PIPE SHALL BE COVERED AT LEAST 50mm THICK OVERLAY AND SHALL BE PAVED WITH AT LEAST:

- 150mm REINFORCED CONCRETE WHERE SUBJECT TO HEAVY VEHICLE TRAFFIC
- 75mm THICKNESS OF BRICK OR 100mm OF CONCRETE PAVING WHERE SUBJECT TO LIGHT VEHICLE TRAFFIC, OR
- 50mm THICK BRICK OR CONCRETE PAVING WHERE NOT SUBJECT TO VEHICLE TRAFFIC.

#### PIT SIZES AND DESIGN

DEPTH (mm)	MINIMUM PIT SIZE (mm)
UP TO 450mm	450 x 450
450mm TO 600mm	600 x 600 U.N.O
600mm TO 900mm	600 x 900 U.N.O
FROM 900mm	900 x 900 (WITH STEP IRON)

#### SYMBOLS

DESCRIPTION	
DENOTE ON-SITE DETENTION TANK OR PUMP OUT TANK	
DENOTE ON-SITE DETENTION BASIN	
DENOTE ABSORPTION TRENCH	
DP DENOTES DOWNPIPE	
DENOTES 100mm DIA PVC (SEWER GRADE) AT 1% MIN. GRADE U.N.O	
DENOTES 150mm DIA PVC (SEWER GRADE) AT 1% MIN. GRADE U.N.O	
DENOTES 225mm DIA PVC (SEWER GRADE) AT 1% MIN. GRADE U.N.O	
DENOTES AGG LINE	
DENOTES SEDIMENT FENCE	
DENOTES INSPECTION OPENING WITH SCREW DOWN LID AT FINISH SURFACE LEVEL	
DENOTES CLEANING EYE	
STORMWATER PIT - GRATED INLET	
STORMWATER PIT - SOLID COVER	
MAINTENANCE PIT	
NON RETURN VALVE	
DENOTE ROUND FLOOR DRAINS	
DENOTE SQUARE FLOOR DRAINS	
DENOTE PLANTER BOX DRAINS	
DENOTE GRATED DRAIN	
PROPOSED FINISH FLOOR LEVEL	
DENOTE EXISTING OVERLAND FLOW PATH	
DENOTE RAINWATER TANK	
DENOTE WATER OUTLET	
REDUCED LEVEL/SURFACE LEVELL	
INVERT LEVEL	
TOP OF KERB	

#### SCHEDULE OF DRAWINGS

SHEET No	DESCRIPTION
COVER	GENERAL NOTES
SW01	SEDIMENT AND EROSION CONTROL PLAN
SW02	BASEMENT 3 DRAINAGE PLAN
SW03	BASEMENT 2 & 1 DRAINAGE PLAN
SW04	GROUND FLOOR DRAINAGE PLAN
SW05	OUTLET LONG SECTION & DRAINS MODEL RESULTS
SW06	STORMWATER SECTIONS AND DETAILS
SW07	WATER SENSITIVE URBANE DESIGN

www.dialbeforeyoudig.com.au



ISSUE FOR DA

Phone: (02) 9745 5202  
 Fax: (02) 8004 7461  
 Email: Info@alphaengineering.com.au  
 Address: 24A Burleigh St,  
 Burwood NSW 2134  
 Website: www.alphaengineering.com.au

COPYRIGHT THIS DRAWING REMAINS THE PROPERTY OF ALPHA ENGINEERING & DEVELOPMENT AND MAY NOT BE ALTERED IN ANY WAY WITHOUT ALPHA ENGINEERING'S WRITTEN CONSENT

#### ARCHITECT

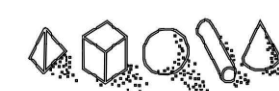

**Barry Rush & Associates Pty Ltd**  
 Architects  
 Suite 25A, 2 Beattie Street, Balmain,  
 NSW, Australia, 2041  
 Phone: (612) 9555 8028 Fax: (612) 9810 0161  
 Email: info@barryrush.com.au  
 www.barryrush.com.au

#### PROJECT

PROPOSED DEVELOPMENT  
 638 PITTWATER ROAD,  
 BROOKVALE

#### DRAWING TITLE

GENERAL NOTES

SCALES AS SHOWN	DESIGNED DM	DRAFTED PS
DRAWING NO. A8256 - COVER	APPROVED JM	REVISION C



REVISION	AMENDMENT	ISSUE DATE
C	AMENDED AS PER COUNCIL'S RFI	29-10-2019
B	ISSUED FOR DA	29-11-2018
A	ISSUED FOR COORDINATION	02-07-2018

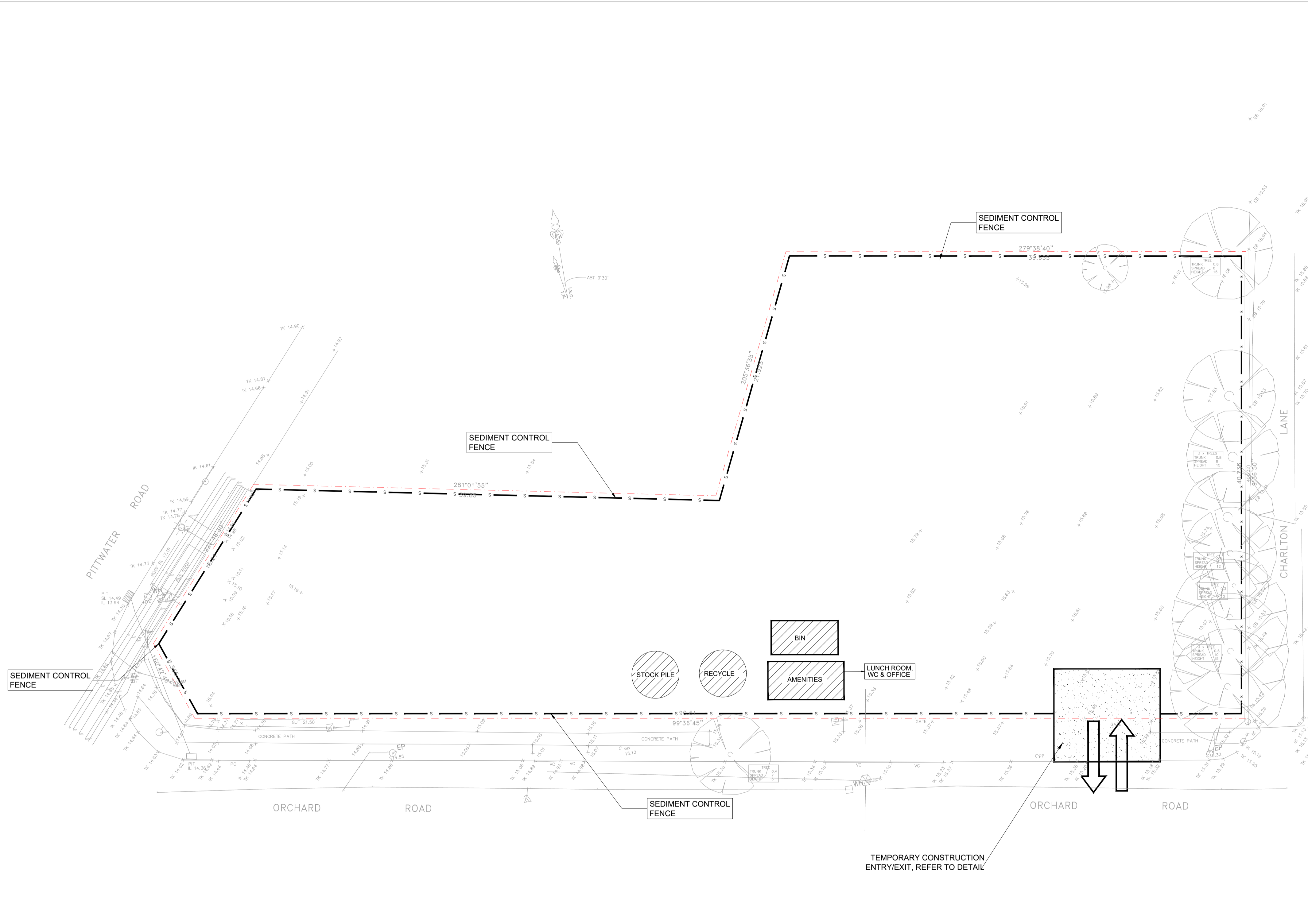

**SEDIMENT AND EROSION CONTROL PLAN**  
1:200 @A1

**SEDIMENT AND EROSION CONTROL NOTES**

SEDIMENT AND EROSION CONTROL SHALL BE EFFECTIVELY MAINTAINED AT ALL TIMES DURING THE COURSE OF CONSTRUCTION AND SHALL NOT BE REMOVED UNTIL THE SITE HAS BEEN STABILISED OR LANDSCAPED TO THE SUPERINTENDENT'S SATISFACTION.  
A SINGLE ALL WEATHER ACCESS WAY WILL BE PROVIDED AT THE FRONT OF THE PROPERTY CONSISTING OF 50-75 AGGREGATE OR SIMILAR MATERIAL AT A MINIMUM THICKNESS OF 150 LAID OVER NEEDLE-PUNCHED GEOTEXTILE FABRIC AND CONSTRUCTED PRIOR TO COMMENCEMENT OF WORKS.  
THE CONTRACTOR SHALL ENSURE THAT NO SPOIL OR FILL ENCROACHES UPON ADJACENT AREAS FOR THE DURATION OF WORKS.  
THE CONTRACTOR SHALL ENSURE THAT KERB INLETS AND DRAINS RECEIVING STORMWATER SHALL BE PROTECTED AT ALL TIMES DURING DEVELOPMENT. KERB INLET SEDIMENT TRAPS SHALL BE INSTALLED ALONG THE IMMEDIATE VICINITY ALONG THE STREET FRONTAGE.  
SEDIMENT FENCING SHALL BE SECURED BY POST (WHERE METAL STAR PICKETS ARE USED PLASTIC SAFETY CAPS SHALL BE USED) AT 2000 INTERVALS WITH GEOTEXTILE FABRIC EMBEDDED 200 IN SOIL.  
ALL TOPSOIL STRIPPED FROM THE SITE AND STOCKPILED DOES NOT INTERFERE WITH DRAINAGE LINES AND STORMWATER INLETS AND WILL BE SUITABLY COVERED WITH AN IMPERVIOUS MEMBRANE MATERIAL AND SCREENED BY SEDIMENT FENCING.  
**SOIL CONSERVATION NOTE:**  
PRIOR TO COMMENCEMENT OF CONSTRUCTION PROVIDE "SEDIMENT FENCE," "SEDIMENT TRAP" AND "WASHOUT AREA" TO ENSURE THE CAPTURE OF WATER BORNE MATERIAL GENERATED FROM THE SITE. MAINTAIN THE ABOVE DURING THE COURSE OF CONSTRUCTION AND CLEAR THE "SEDIMENT TRAP" AFTER EACH STORM.  
**SEDIMENT TRAP**  
1000 x 1000 WIDE 500 DEEP PIT, LOCATED AT THE LOWEST POINT TO THE TRAP SEDIMENT.

**WASHOUT AREA**  
TO BE 1800 x 1800 ALLOCATED FOR THE WASHING OF TOOL & EQUIPMENT

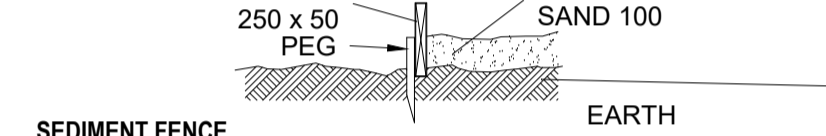

**SEDIMENT FENCE**  
PROVIDE "SEDIMENT FENCE" ON DOWN SLOPE BOUNDARY AS SHOWN ON PLAN. FABRIC TO BE BURIED BELOW GROUND AT LOWER EDGE.

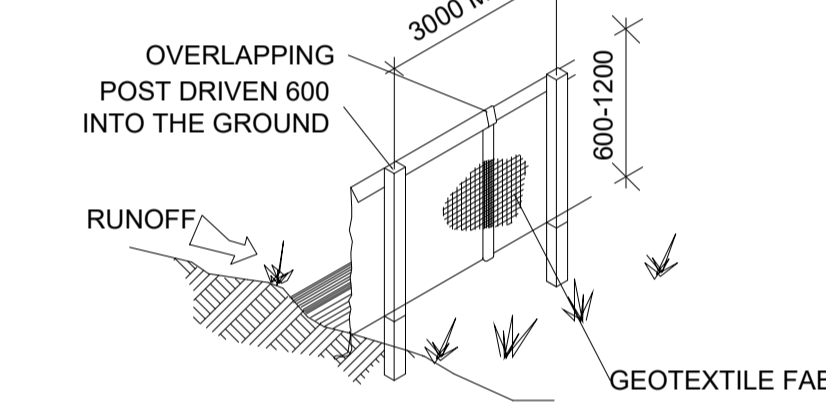

STAKES DRIVEN 600 INTO THE GROUND WITH FIRST STAKE ANGLED TOWARDS PREVIOUSLY Laid BALE  
GEOTEXTILE FILTER FABRIC FASTEN ON TOP EDGE

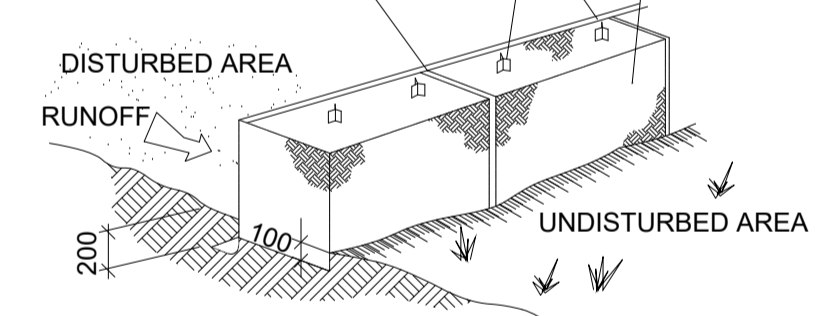

DRAINAGE AREA 0.5 HA. MAX. SLOPE GRADIENT 1:2 MAX. SLOPE LENGTH 50m.

**VEHICLE ACCESS TO SITE**

VEHICLE ACCESS TO THE BUILDING SITE SHOULD BE RESTRICTED TO A SINGLE POINT SO AS TO REDUCE THE AMOUNT OF SOIL DEPOSITED ON THE STREET PAVEMENT.

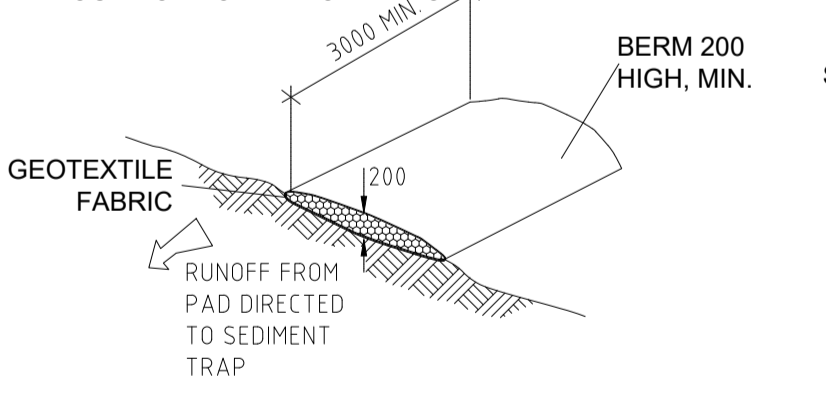

**GENERAL NOTES**

THESE DRAWINGS SHALL BE READ IN CONJUNCTION WITH OTHER CONSULTANTS' DRAWINGS AND SPECIFICATIONS AND WITH OTHER SUCH WRITTEN INSTRUCTIONS AS MAY BE ISSUED DURING THE COURSE OF THE CONTRACT. ANY DISCREPANCY SHALL BE REFERRED TO THE ENGINEER BEFORE PROCEEDING WITH THE WORK.  
ALL DIMENSIONS ARE IN MILLIMETRES & ALL LEVELS ARE IN METRES, UNO (UNLESS NOTED OTHERWISE).  
NO DIMENSION SHALL BE OBTAINED BY SCALING THE DRAWINGS.  
ALL LEVELS AND SETTING OUT DIMENSIONS SHOWN ON THE DRAWINGS SHALL BE CHECKED ON SITE PRIOR TO THE COMMENCEMENT OF THE WORK.  
DURING EXCAVATION WORK THE STRUCTURE SHALL BE MAINTAINED IN A STABLE AND NO PART SHALL BE OVERSTRESSED.  
ALL WORK IS TO BE UNDERTAKEN IN ACCORDANCE WITH THE DETAILS SHOWN ON THE DRAWINGS & THE SPECIFICATION.  
EXISTING SERVICES WHERE SHOWN HAVE BEEN PLOTTED FROM SUPPLIED DATA AND SUCH THEIR ACCURACY CAN NOT BE GUARANTEED. IT IS THE RESPONSIBILITY OF THE CONTRACTOR TO ESTABLISH THE LEVEL OF ALL EXISTING SERVICES PRIOR TO THE COMMENCEMENT OF WORK.  
ALL SERVICE TRENCHES UNDER VEHICULAR PAVEMENTS SHALL BE BACK FILLED IN ACCORDANCE WITH THE REQUIREMENTS OF THE LOCAL COUNCIL.  
ALL TRENCH BACK FILL MATERIAL SHALL BE COMPACTED TO THE SAME DENSITY AS THE ADJACENT MATERIAL.  
ON COMPLETION OF STORMWATER INSTALLATION, ALL DISTURBED AREAS MUST BE RESTORED TO ORIGINAL CONDITION, INCLUDING KERBS, FOOTPATHS, CONCRETE AREAS, GRAVEL AND GRASS AREAS AND ROAD PAVEMENTS, UNLESS DIRECTED OTHERWISE.

**STORMWATER DRAINAGE**

THE STORMWATER DRAINAGE DESIGN HAS BEEN CARRIED OUT IN ACCORDANCE WITH AS/NZS 3500.3 - 1990 "STORMWATER DRAINAGE" & AS/NZS 3500.3.2-1998 "STORMWATER DRAINAGE - ACCEPTABLE SOLUTIONS".  
ANY VARIATIONS TO THE NOMINATED LEVELS SHALL BE REFERRED TO ENGINEER IMMEDIATELY.  
ANY VARIATIONS TO SPECIFIED PRODUCTS OR DETAILS SHALL BE REFERRED TO THE ENGINEER FOR APPROVAL.  
DOWN PIPES SHALL BE A MINIMUM OF DN100 SW GRADE UPVC OR 100X100 COLORBOND/ZINCALUME STEEL, UNO.  
BOX COLORBOND OR ZINCALUME STEEL. GUTTERS SHALL BE A MINIMUM OF 450 WIDE X 150 DEEP.  
EAVES GUTTERS SHALL BE A MINIMUM OF 125 WIDE X 100 DEEP (OR OF EQUIVALENT AREA) COLORBOND OR ZINCALUME STEEL.

**SUBSOIL DRAINAGE SHALL BE PROVIDED TO ALL RETAINING WALLS & EMBANKMENTS, WITH THE LINES FEEDING INTO THE STORMWATER DRAINAGE SYSTEM.**

**BUILDING MATERIAL STOCKPILES**

ALL STOCKPILES OF BUILDING MATERIAL SUCH AS SAND AND SOIL MUST BE PROTECTED TO PREVENT SCOUR AND SHOULD NEVER BE PLACED IN THE STREET GUTTER WHERE THEY WILL WASH AWAY WITH THE FIRST RAINSTORM.  
WATERPROOF COVERING  
EARTH BANK TO PREVENT SCOUR OF STOCKPILE  
SEDIMENT FENCE

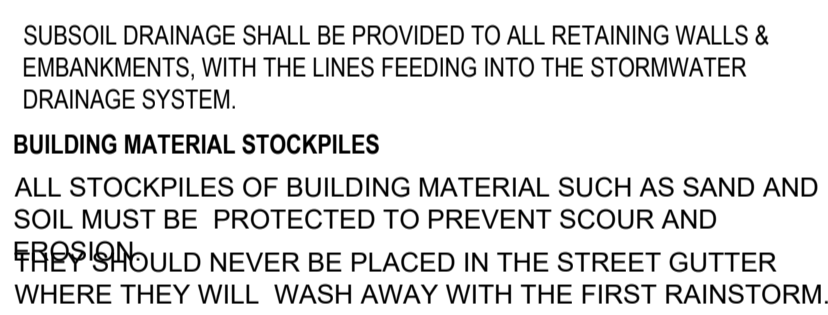

**SANDBAG KERB SEDIMENT TRAP**

IN CERTAIN CIRCUMSTANCES EXTRA SEDIMENT TRAPPING MAY BE NEEDED IN THE STREET GUTTER.

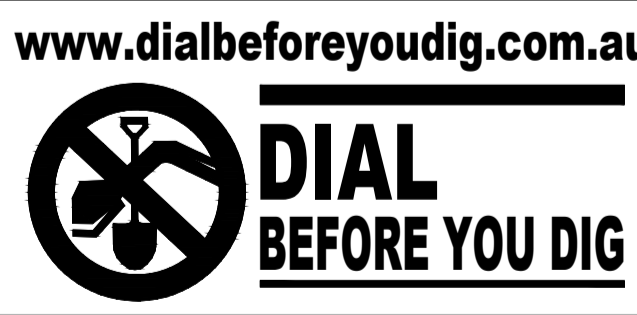
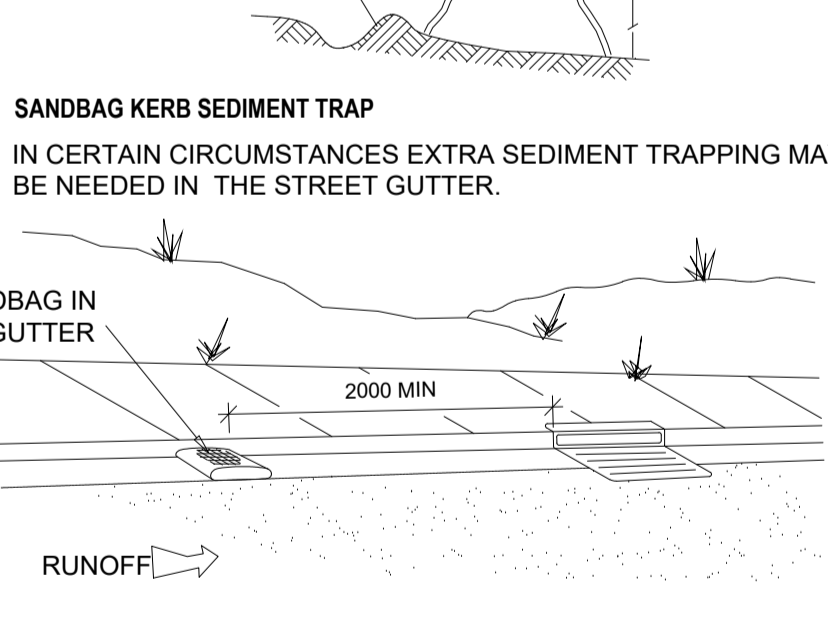

**ISSUE FOR DA**

REVISION	AMENDMENT	ISSUE DATE
C	AMENDED AS PER COUNCIL'S RFI	29-10-2019
B	ISSUED FOR DA	29-11-2018
A	ISSUED FOR COORDINATION	02-07-2018



Phone: (02) 9745 5202  
Fax: (02) 8004 7461  
Email: [Info@alphaengineering.com.au](mailto:Info@alphaengineering.com.au)  
Address: 24A Burleigh St, Burwood NSW 2134  
Website: [www.alphaengineering.com.au](http://www.alphaengineering.com.au)  
COPYRIGHT THIS DRAWING REMAINS THE PROPERTY OF ALPHA ENGINEERING & DEVELOPMENT AND MAY NOT BE ALTERED IN ANY WAY WITHOUT ALPHA ENGINEERING'S WRITTEN CONSENT

**ARCHITECT**  
  
**Barry Rush & Associates Pty Ltd**  
Architects  
Suite 25A, 2 Beattie Street, Belmain, NSW, Australia, 2041  
Phone: (612) 9555 8028 Fax: (612) 9810 0161  
Email: [info@barryrush.com.au](mailto:info@barryrush.com.au)  
[www.barryrush.com.au](http://www.barryrush.com.au)

**PROJECT**  
**PROPOSED DEVELOPMENT**  
**638 PITTWATER ROAD,**  
**BROOKVALE**

DRAWING TITLE		
SEDIMENT AND EROSION CONTROL PLAN		
SCALES AS SHOWN	DESIGNED DM	DRAFTED PS
DRAWING NO. A8256 - SW01	APPROVED JM	REVISION C

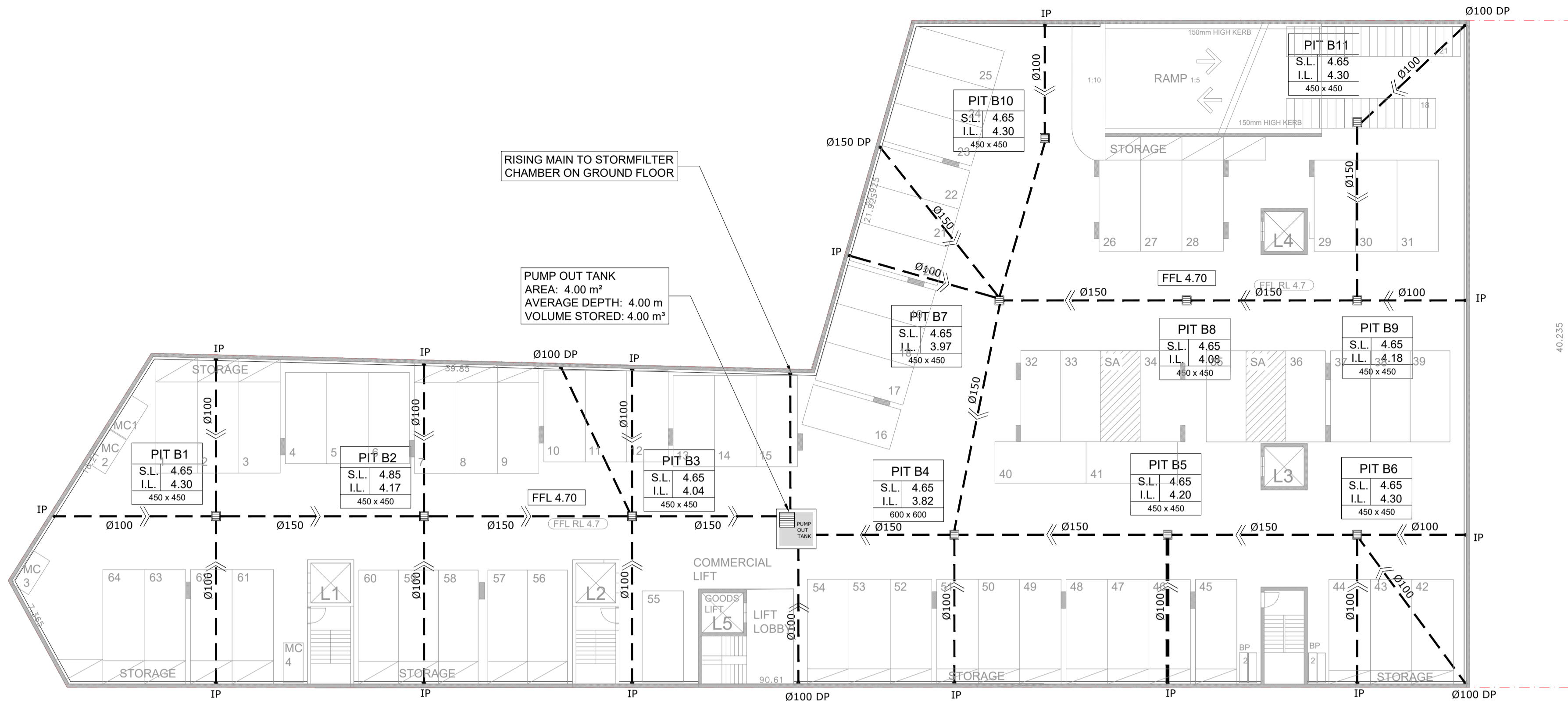
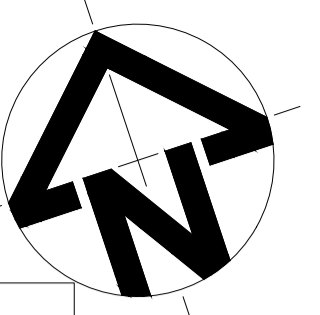

### BASEMENT 3 DRAINAGE PLAN

1:200 @ A1

ALL DRAINAGE LINES SHALL BE UPVC (CLASS SH) STORMWATER DRAINAGE PIPE, UNO.  
 ALL DRAINAGE LINES SHALL BE LAID @ 1% FALL MIN. UNO. FIRST FLUSH RAINWATER DEVICES TO BE FITTED TO DRAINAGE LINES TO BUILDER'S DETAIL, TYPICAL MINIMUM EFFECTIVE EAVES GUTTER SIZE = 6700 mm²  
 MINIMUM EFFECTIVE EAVES GUTTER SLOPE = 1:500

THE FOLLOWING SYMBOLS & ABBREVIATIONS HAVE BEEN USED:

- DP = Ø150, UNO.
- FD = FLOOR OUTLET, REFER TO DETAIL
- SIP = SURFACE INLET PIT (NO LINTEL)
- 1000 = Ø100 CHARGED LINE
- IP = Ø150 INSPECTION POINT
- RWH = RAIN WATER HEAD
- RWO = RAIN WATER OUTLET (300 x 300)
- FG = FLOOR GULLY Ø150
- S<sup>IP</sup> = RAINWATER SPREADER
- RL 6.20 = PROPOSED FINISHED SURFACE LEVEL
- HR = HEAD ROOM UNDER PIPE

- BASEMENT SLAB TO HAVE 1% MIN. FALL TO INLET PIT AS PER AS2890 REQUIREMENT
- ALL BASEMENT PIT TO BE FITTED WITH HEAVY DUTY CLASS C GRATE & FRAME

### PUMP DESIGN SUMMARY

CATCHMENT AREA = 0.00 m² (NO UNDER COVER AREA)  
 PUMP OUT TANK VOLUME PROVIDED = 4.0 m³ (MINIMUM VOLUME AS PER AS STANDARD)  
 PUMP HEAD = 4 m  
 PUMP RATE REQUIRED = 210 x 43.4 / 3600 = 3 l/s

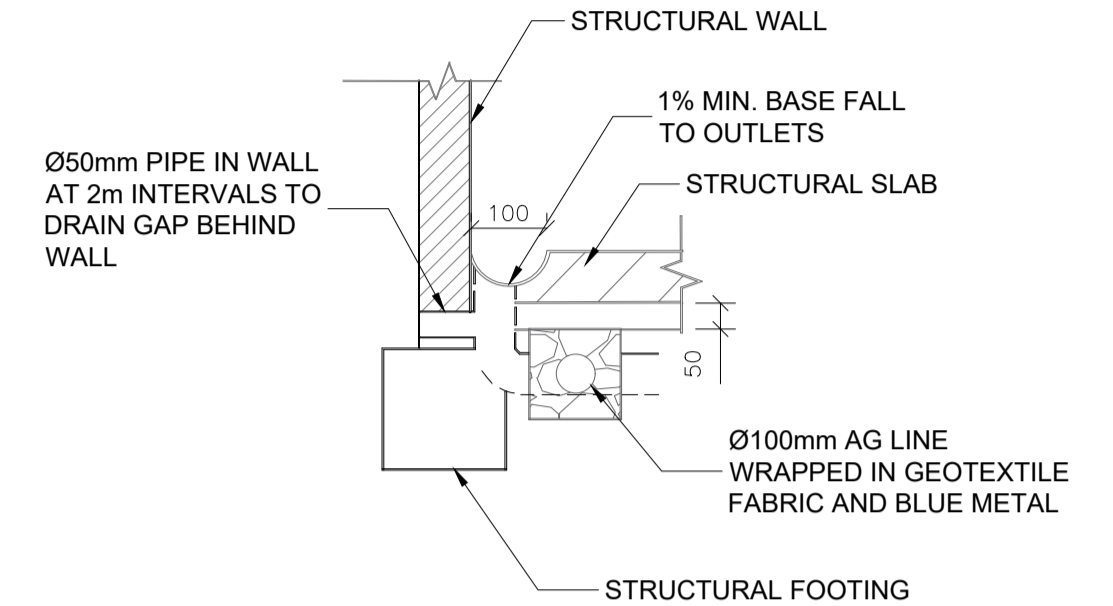

SECTION - SUBSOIL DRAINAGE DETAILS  
1:10

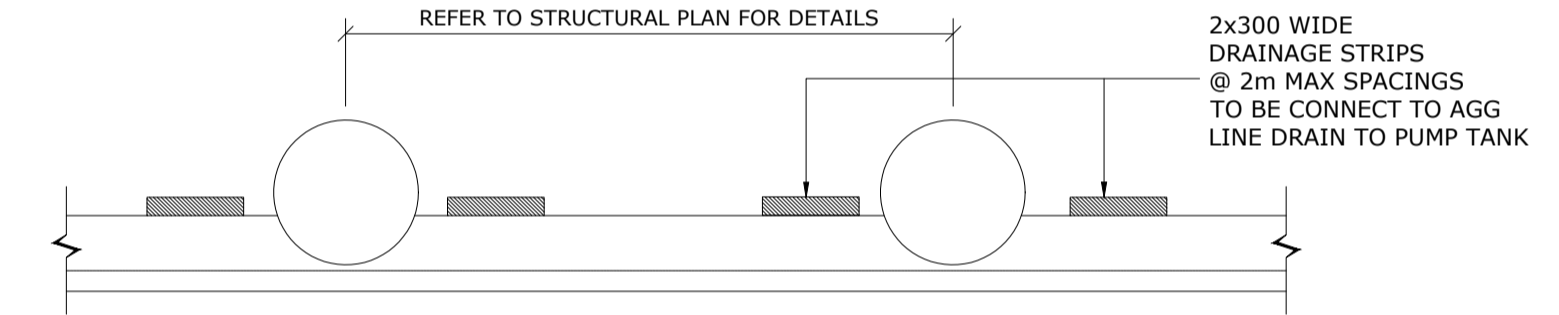

SECTION - SHOTCRETE WALL DRAINAGE  
NTS

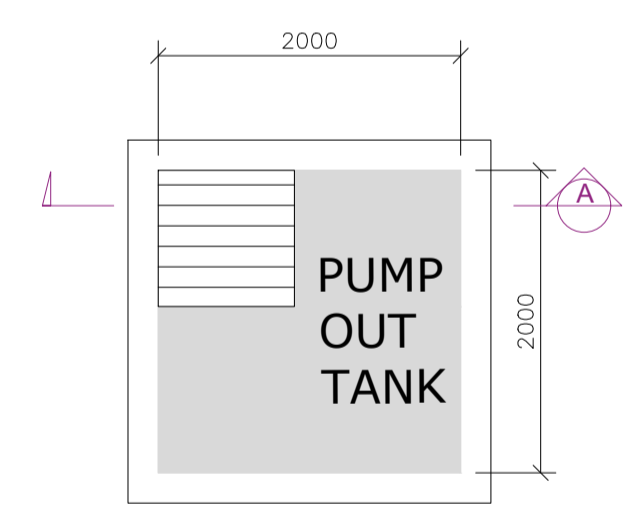

PUMP OUT TANK PLAN  
1:50 @ A1

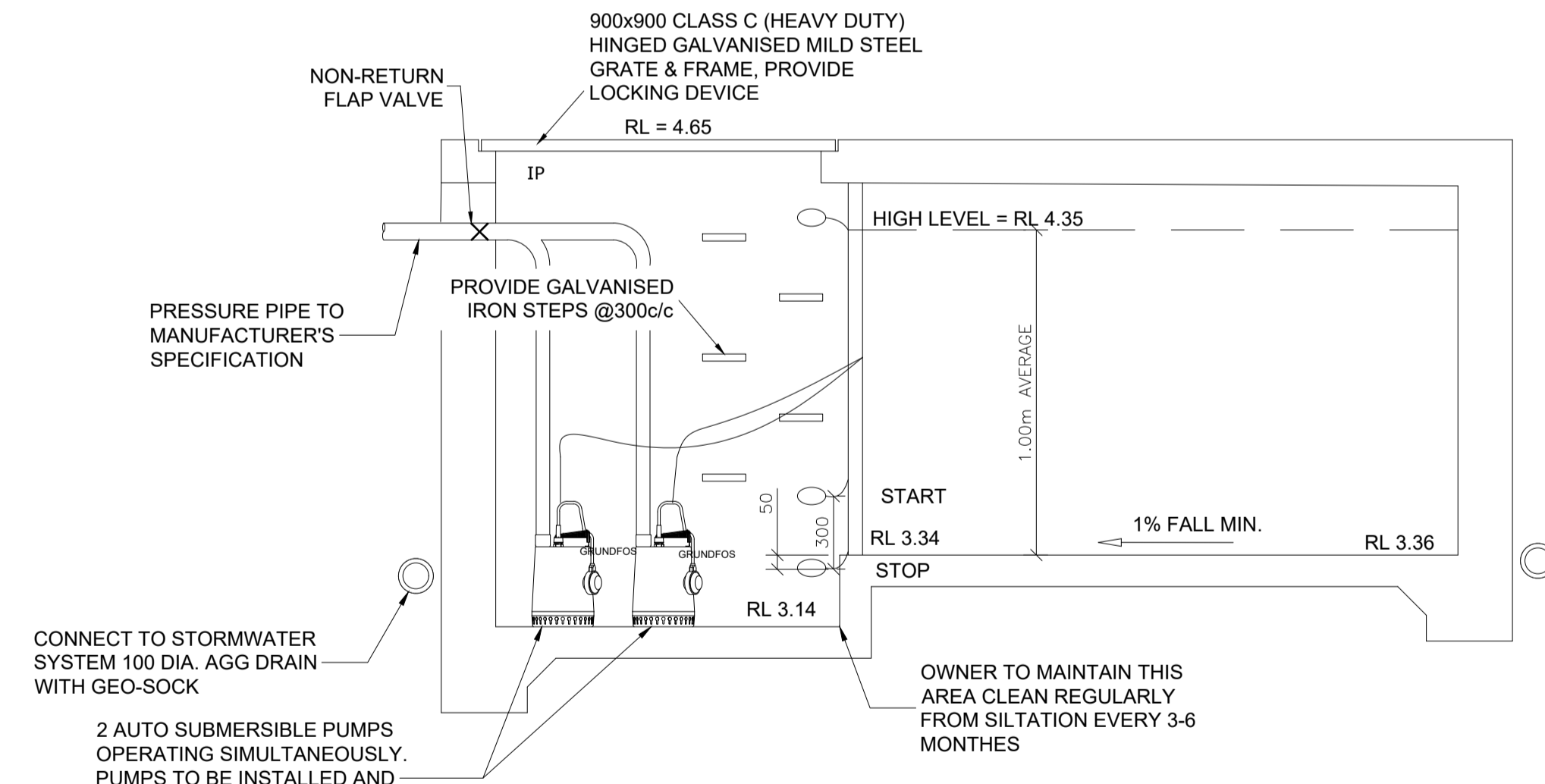

SECTION A - SUBSOIL DRAINAGE PUMPOUT PIT  
1:20



ISSUE FOR DA

REVISION	AMENDMENT	ISSUE DATE
C	AMENDED AS PER COUNCIL'S RFI	29-10-2019
B	ISSUED FOR DA	29-11-2018
A	ISSUED FOR COORDINATION	02-07-2018



Phone: (02) 9745 5202  
 Fax: (02) 8004 7461  
 Email: [Info@alphaengineering.com.au](mailto:Info@alphaengineering.com.au)  
 Address: 24A Burleigh St,  
 Burwood NSW 2134  
 Website: [www.alphaengineering.com.au](http://www.alphaengineering.com.au)

COPYRIGHT THIS DRAWING REMAINS THE PROPERTY OF ALPHA ENGINEERING & DEVELOPMENT AND MAY NOT BE ALTERED IN ANY WAY WITHOUT ALPHA ENGINEERING'S WRITTEN CONSENT

ARCHITECT  
  
**Barry Rush & Associates Pty Ltd**  
 Architects  
 Suite 25A, 2 Beattie Street, Balmain,  
 NSW, Australia, 2041  
 Phone: (612) 9555 8028 Fax: (612) 9810 0161  
 Email: [info@barryrush.com.au](mailto:info@barryrush.com.au)  
[www.barryrush.com.au](http://www.barryrush.com.au)

PROJECT  
**PROPOSED DEVELOPMENT  
 638 PITTWATER ROAD,  
 BROOKVALE**

DRAWING TITLE		
BASEMENT 3 DRAINAGE PLAN		
SCALES AS SHOWN	DESIGNED DM	DRAFTED PS
DRAWING NO. A8256 - SW02	APPROVED JM	REVISION C

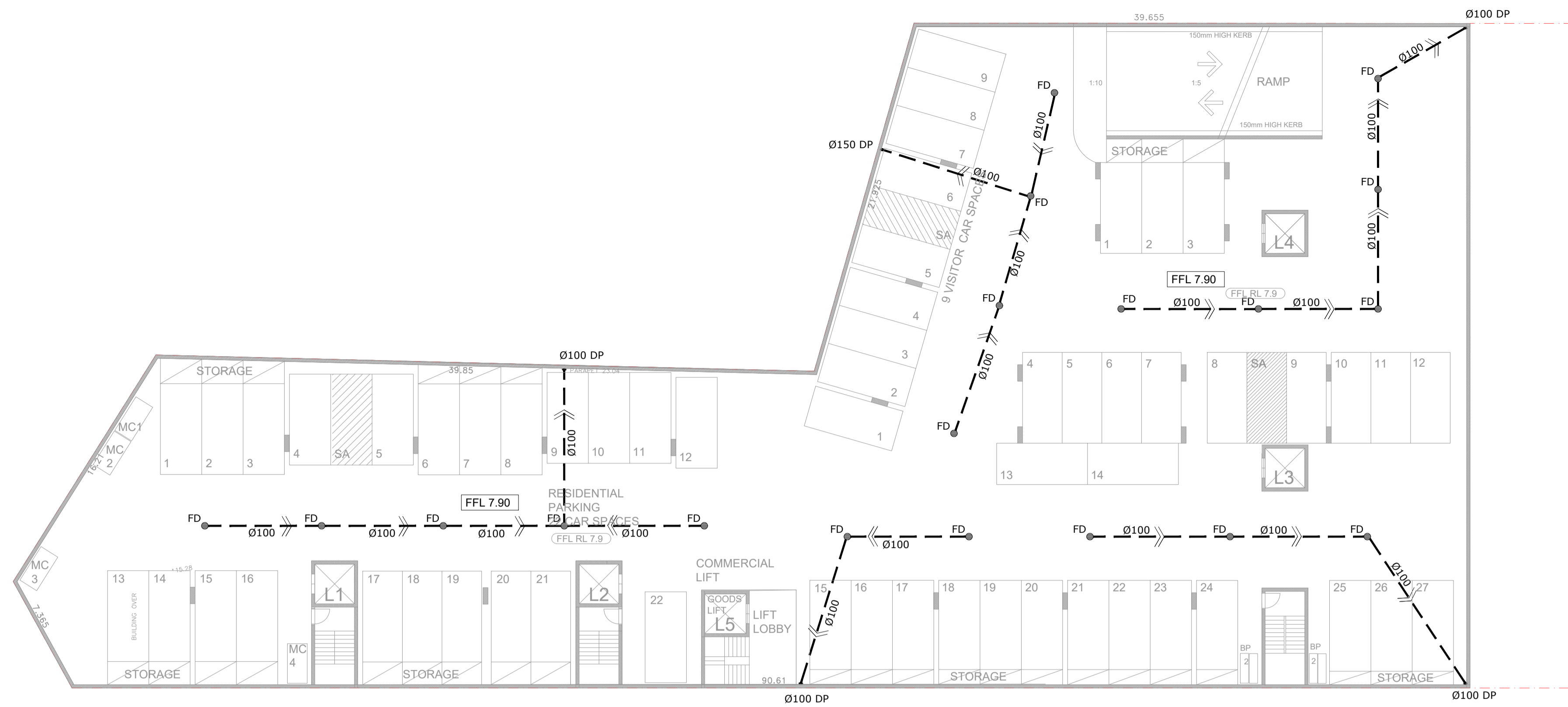
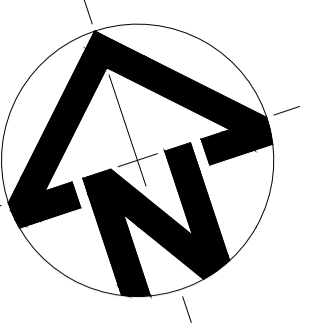

### BASEMENT 2 DRAINAGE PLAN

1:200 @ A1

ALL DRAINAGE LINES SHALL BE UPVC (CLASS SH) STORMWATER DRAINAGE PIPE, UNO.

ALL DRAINAGE LINES SHALL BE LAID @ 1% FALL MIN. UNO. FIRST FLUSH RAINWATER DEVICES TO BE FITTED TO DRAINAGE LINES TO BUILDER'S DETAIL, TYPICAL MINIMUM EFFECTIVE EAVES GUTTER SIZE = 6700 mm<sup>2</sup> MINIMUM EFFECTIVE EAVES GUTTER SLOPE = 1:500

THE FOLLOWING SYMBOLS & ABBREVIATIONS HAVE BEEN USED:

- DP = Ø150, UNO.
- FD = FLOOR OUTLET, REFER TO DETAIL
- SIP = SURFACE INLET PIT (NO LINTEL)
- 100Ø = Ø100 CHARGED LINE
- IP = Ø150 INSPECTION POINT
- RWH = RAIN WATER HEAD
- RWO = RAIN WATER OUTLET (300 x 300)
- FG = FLOOR GULLY Ø150
- S<sub>RP</sub> = RAINWATER SPREADER
- RL 6.20 = PROPOSED FINISHED SURFACE LEVEL

- BASEMENT SLAB TO HAVE 1% MIN. FALL TO INLET PIT AS PER AS2890 REQUIREMENT
- ALL BASEMENT PIT TO BE FITTED WITH HEAVY DUTY CLASS C GRATE & FRAME

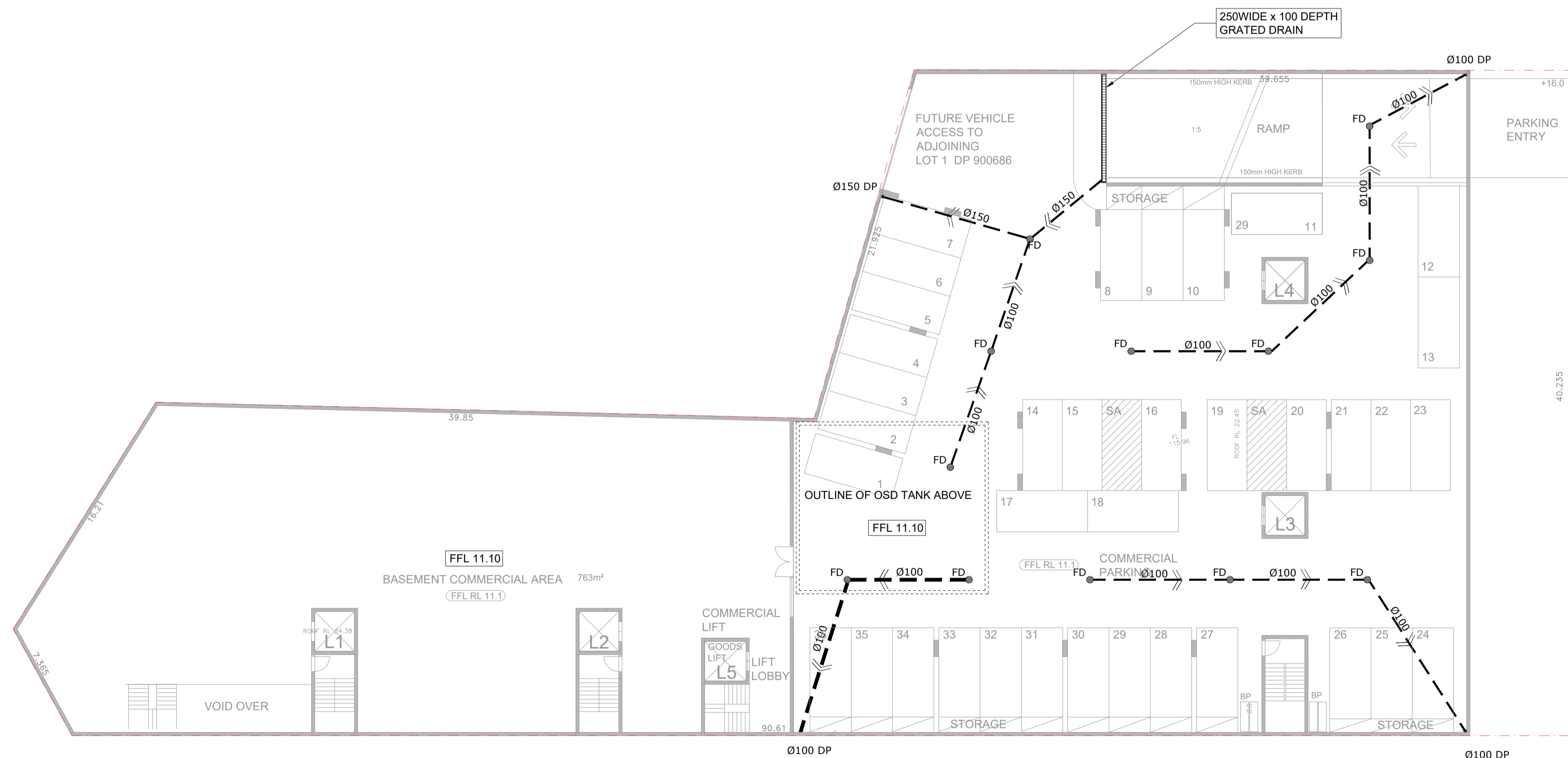

### BASEMENT 1 DRAINAGE PLAN

1:200 @ A1

ALL DRAINAGE LINES SHALL BE UPVC (CLASS SH) STORMWATER DRAINAGE PIPE, UNO.

ALL DRAINAGE LINES SHALL BE LAID @ 1% FALL MIN. UNO. FIRST FLUSH RAINWATER DEVICES TO BE FITTED TO DRAINAGE LINES TO BUILDER'S DETAIL, TYPICAL MINIMUM EFFECTIVE EAVES GUTTER SIZE = 6700 mm<sup>2</sup> MINIMUM EFFECTIVE EAVES GUTTER SLOPE = 1:500

THE FOLLOWING SYMBOLS & ABBREVIATIONS HAVE BEEN USED:

- DP = Ø150, UNO.
- FD = FLOOR OUTLET, REFER TO DETAIL
- SIP = SURFACE INLET PIT (NO LINTEL)
- 100Ø = Ø100 CHARGED LINE
- IP = Ø150 INSPECTION POINT
- RWH = RAIN WATER HEAD
- RWO = RAIN WATER OUTLET (300 x 300)
- FG = FLOOR GULLY Ø150
- S<sub>RP</sub> = RAINWATER SPREADER
- RL 6.20 = PROPOSED FINISHED SURFACE LEVEL
- HR = HEAD ROOM UNDER PIPE

- BASEMENT SLAB TO HAVE 1% MIN. FALL TO INLET PIT AS PER AS2890 REQUIREMENT
- ALL BASEMENT PIT TO BE FITTED WITH HEAVY DUTY CLASS C GRATE & FRAME

www.dialbeforeyoudig.com.au



ISSUE FOR DA

REVISION	AMENDMENT	ISSUE DATE
C	AMENDED AS PER COUNCIL'S RFI	29-10-2019
B	ISSUED FOR DA	29-11-2018
A	ISSUED FOR COORDINATION	02-07-2018



Phone: (02) 9745 5202  
 Fax: (02) 8004 7461  
 Email: [Info@alphaengineering.com.au](mailto:Info@alphaengineering.com.au)  
 Address: 24A Burleigh St,  
 Burwood NSW 2134  
 Website: [www.alphaengineering.com.au](http://www.alphaengineering.com.au)

COPYRIGHT THIS DRAWING REMAINS THE PROPERTY OF ALPHA ENGINEERING & DEVELOPMENT AND MAY NOT BE ALTERED IN ANY WAY WITHOUT ALPHA ENGINEERING'S WRITTEN CONSENT

ARCHITECT

**Barry Rush & Associates Pty Ltd**  
 Architects  
 Suite 25A, 2 Beattie Street, Balmain,  
 NSW, Australia, 2041  
 Phone: (612) 9555 8028 Fax: (612) 9810 0161  
 Email: [info@barynrush.com.au](mailto:info@barynrush.com.au)  
[www.barynrush.com.au](http://www.barynrush.com.au)

PROJECT

**PROPOSED DEVELOPMENT  
 638 PITTWATER ROAD,  
 BROOKVALE**

DRAWING TITLE		
BASEMENT 2 & 1 DRAINAGE PLAN		
SCALES AS SHOWN	DESIGNED DM	DRAFTED PS
DRAWING NO. A8256 - SW03	APPROVED JM	REVISION C

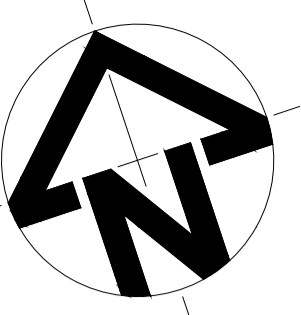

**DESIGN SUMMARY**  
 TOTAL SITE AREA = 2662 m<sup>2</sup>  
 DRAINS MODEL HAS BEEN PREPARED FOR  
 CALCULATION OF PRE & POST  
 DEVELOPMENT FLOWS, USING ILSAX  
 (NORMAL CONTROL)

**PRE - DEVELOPMENT**  
 EXISTING IMPERVIOUS AREA = 2662 m<sup>2</sup>

**POST - DEVELOPMENT**  
 PROPOSED IMPERVIOUS AREA = 2510 m<sup>2</sup>  
 (94.30% OF TOTAL SITE AREA)

**OSD TANK**  
 CATCHMENT AREA = 2662 m<sup>2</sup>  
 IMPREVIOUS AREA = 2510 m<sup>2</sup>  
 PREVIOUS AREA = 152 m<sup>2</sup>  
 ORIFICE SIZE = 205mm

### DRAINS MODEL RESULT

ARI	EX. SITE		POST DEVELOPMENT	
	Q <sub>PRE</sub> (l/s)	OSD TANK Q <sub>POST</sub> (l/s)	TOTAL Q <sub>POST</sub> (l/s)	
100	114	71	71	
10	78	59	59	

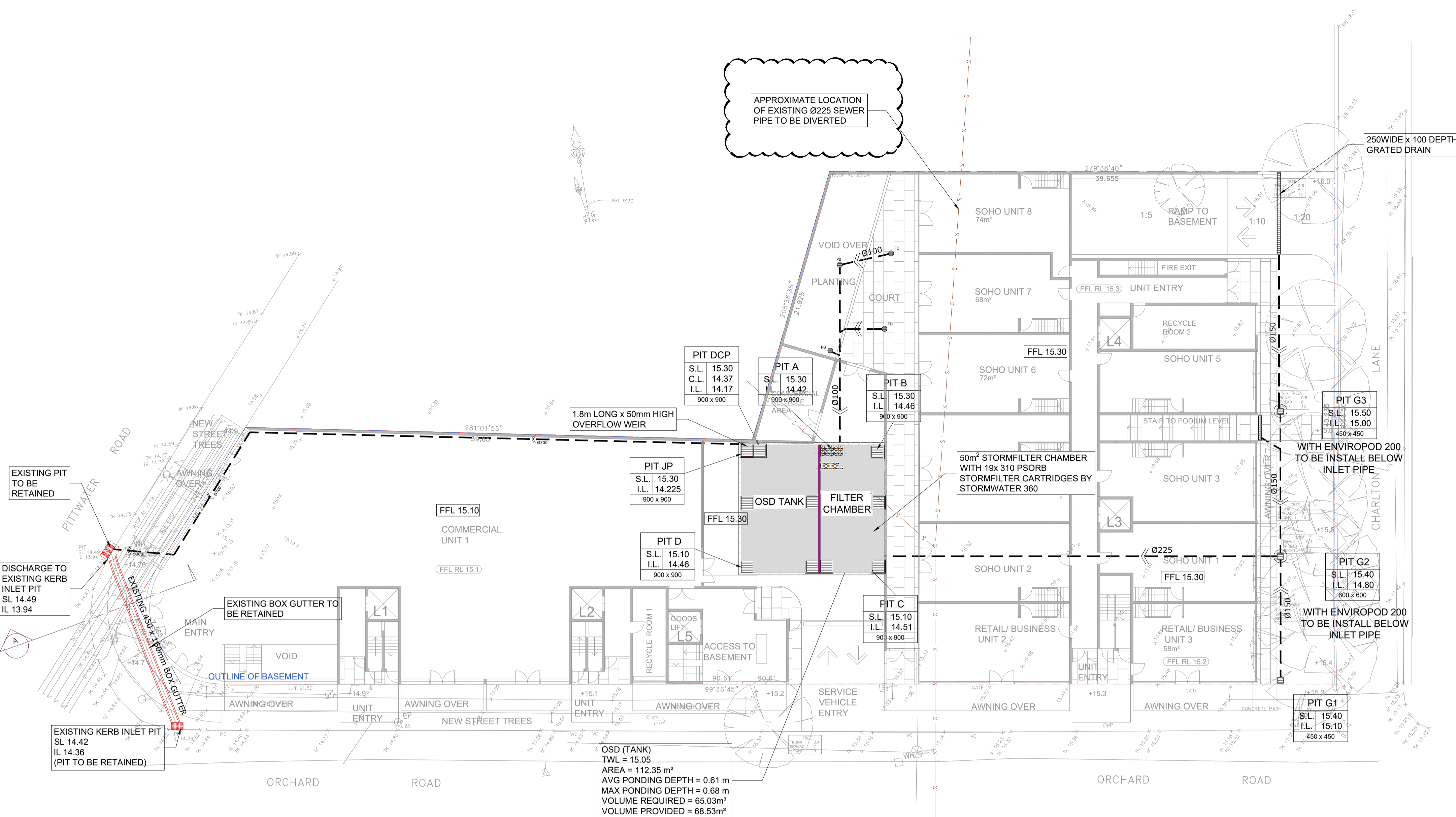

### GROUND FLOOR DRAINAGE PLAN

1:200 @ A1

ALL DRAINAGE LINES SHALL BE UPVC (CLASS SH) STORMWATER DRAINAGE PIPE, UNO.

ALL DRAINAGE LINES SHALL BE LAID @ 1% FALL MIN. UNO. FIRST FLUSH RAINWATER DEVICES TO BE FITTED TO DRAINAGE LINES TO BUILDER'S DETAIL, TYPICAL MINIMUM EFFECTIVE EAVES GUTTER SIZE = 6700 mm<sup>2</sup> MINIMUM EFFECTIVE EAVES GUTTER SLOPE = 1:500

THE FOLLOWING SYMBOLS & ABBREVIATIONS HAVE BEEN USED:

- DP = Ø150, UNO.
- FD = FLOOR OUTLET, REFER TO DETAIL
- SIP = SURFACE INLET PIT (NO LINTEL)
- 100Ø = Ø100 CHARGED LINE
- IP = Ø150 INSPECTION POINT
- RWH = RAIN WATER HEAD
- RWO = RAIN WATER OUTLET (300 x 300)
- FG = FLOOR GULLY Ø150
- S<sub>SP</sub> = RAINWATER SPREADER
- RL 6.20 = PROPOSED FINISHED SURFACE LEVEL

PIPE CAPACITY CALCULATION			
Diameter (D) =	0.3 m	1/2 Pipe	
Hydraulic Radius (R <sub>h</sub> )	0.075 m <sup>2</sup> /m	0.038 m <sup>2</sup> /m	
Area =	0.071 m <sup>2</sup>	0.035 m <sup>2</sup>	
Slope =	0.5 %	0.5 %	
n =	0.011	0.011	
Capacity Q =	80.81 l/s	25.45 l/s	

PIPE CAPACITY CALCULATION  
 NTS

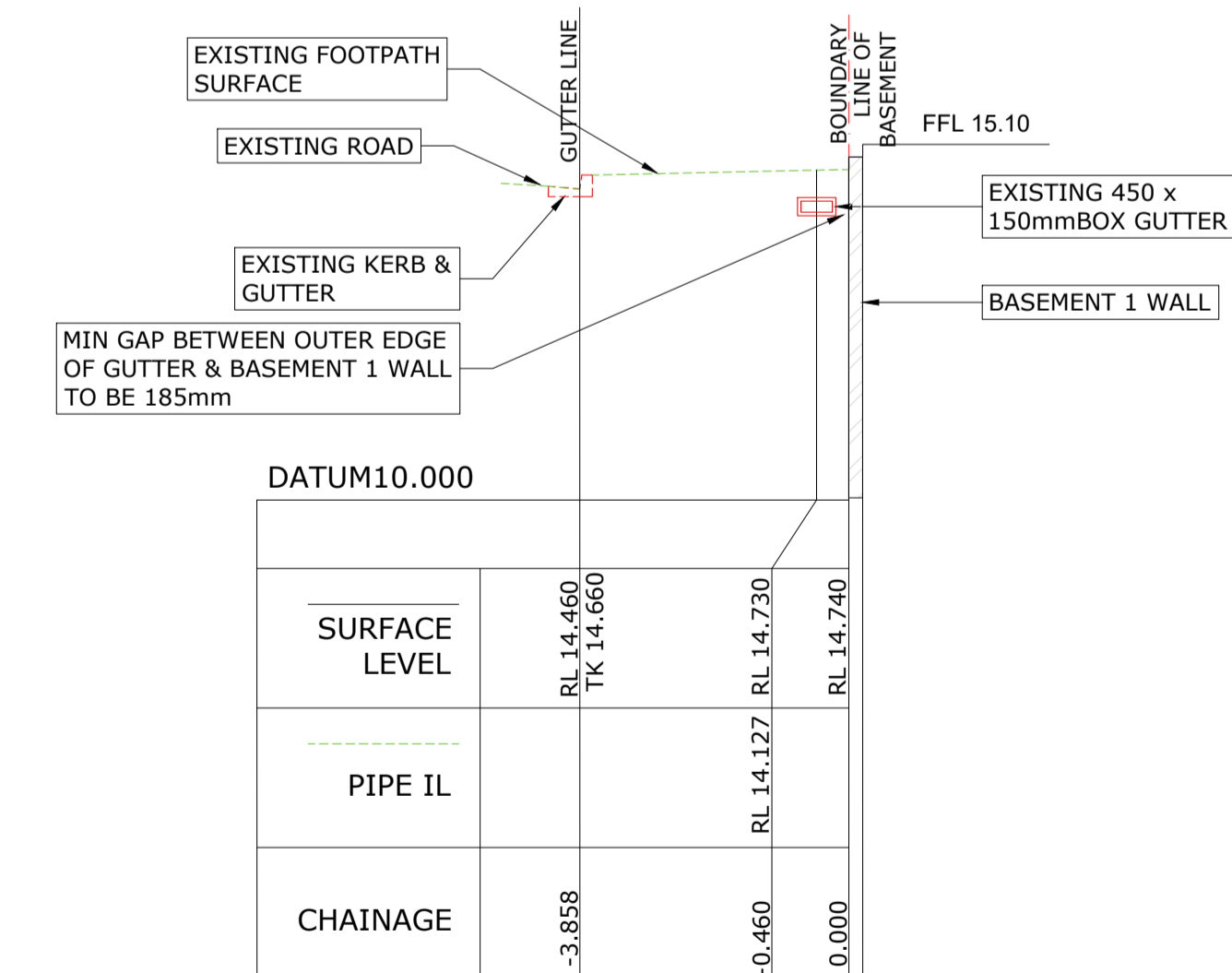
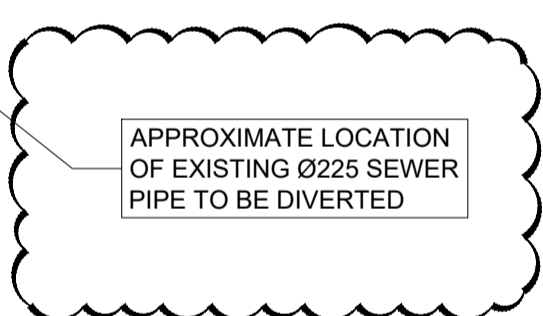

CROSS SECTION AT SECTION A  
 1:100 @ A1



ISSUE FOR DA



Phone: (02) 9745 5202  
 Fax: (02) 8004 7461  
 Email: Info@alphaengineering.com.au  
 Address: 24A Burleigh St, Burwood NSW 2134  
 Website: www.alphaengineering.com.au  
 COPYRIGHT THIS DRAWING REMAINS THE PROPERTY OF ALPHA ENGINEERING & DEVELOPMENT AND MAY NOT BE ALTERED IN ANY WAY WITHOUT ALPHA ENGINEERING'S WRITTEN CONSENT

**ARCHITECT**  
  
 Barry Rush & Associates Pty Ltd  
 Architects  
 Suite 25A, 2 Beattie Street, Balmain, NSW, Australia, 2041  
 Phone: (612) 9555 8028 Fax: (612) 9810 0161  
 Email: info@barryrush.com.au  
 www.barryrush.com.au

**PROJECT**  
 PROPOSED DEVELOPMENT  
 638 PITTWATER ROAD,  
 BROOKVALE

DRAWING TITLE		
GROUND FLOOR DRAINAGE PLAN		
SCALES AS SHOWN	DESIGNED DM	DRAFTED PS
DRAWING NO. A8256 - SW04	APPROVED JM	REVISION C

REVISION	AMENDMENT	ISSUE DATE
C	AMENDED AS PER COUNCIL'S RFI	29-10-2019
B	ISSUED FOR DA	29-11-2018
A	ISSUED FOR COORDINATION	02-07-2018

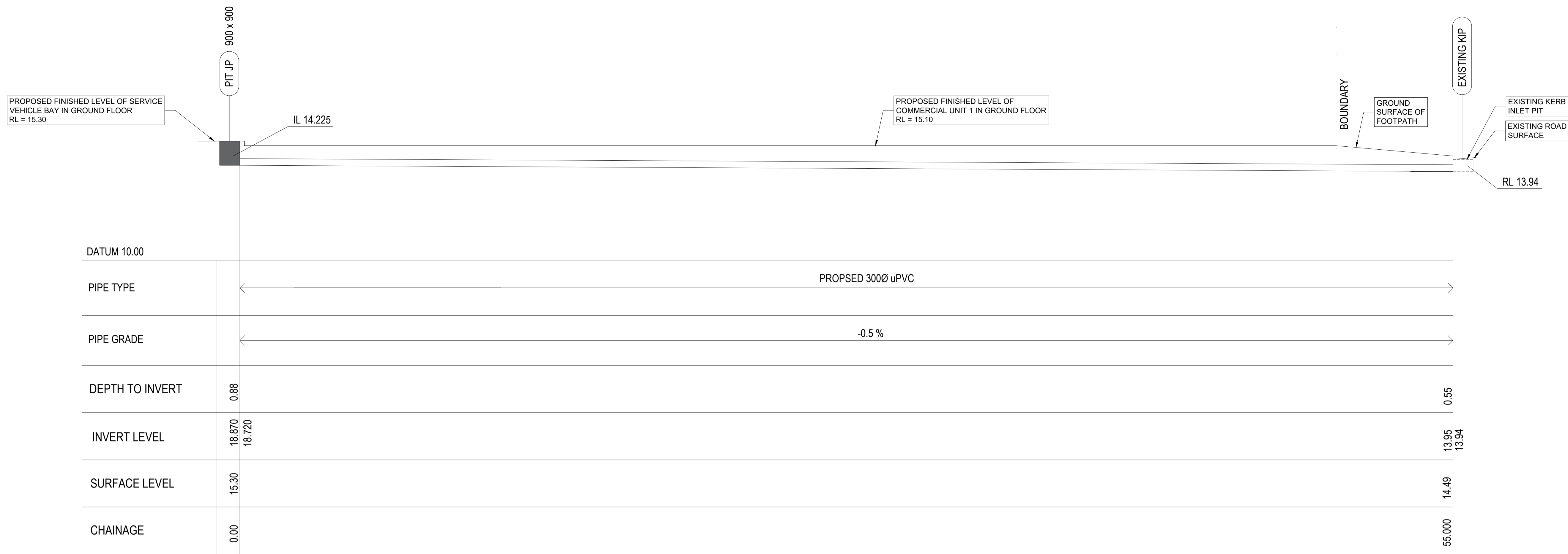

### OUTLET PIPE LONG SECTION

1:100(H & V) @A1

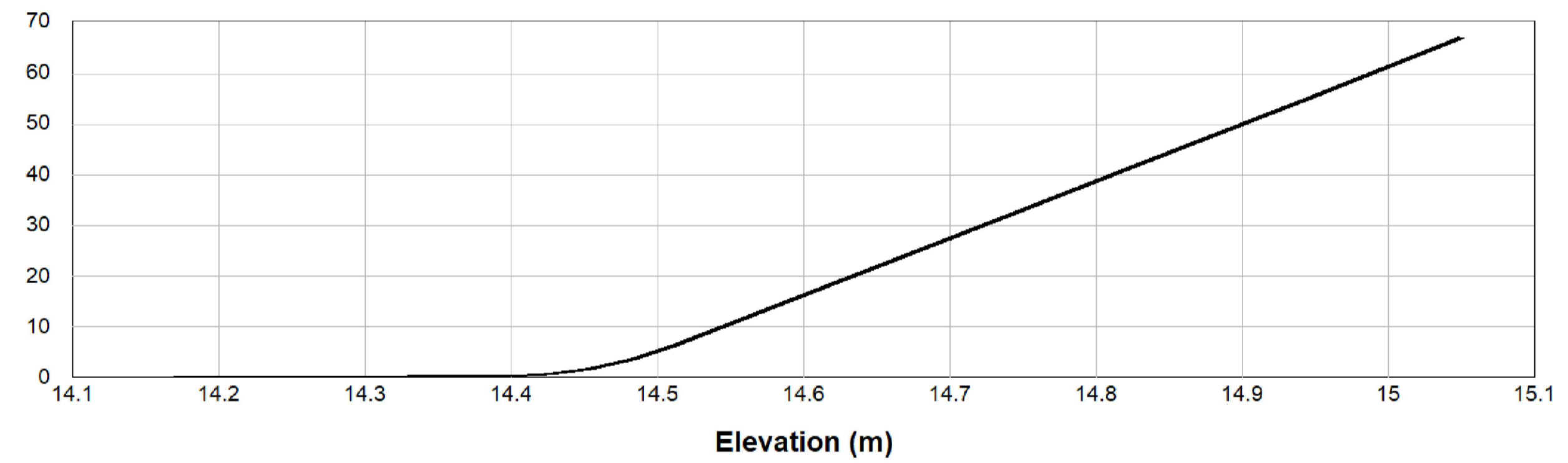

1% OSD TANK STORAGE STAGE VS VOLUME

### DRAINS MODEL LAYOUT

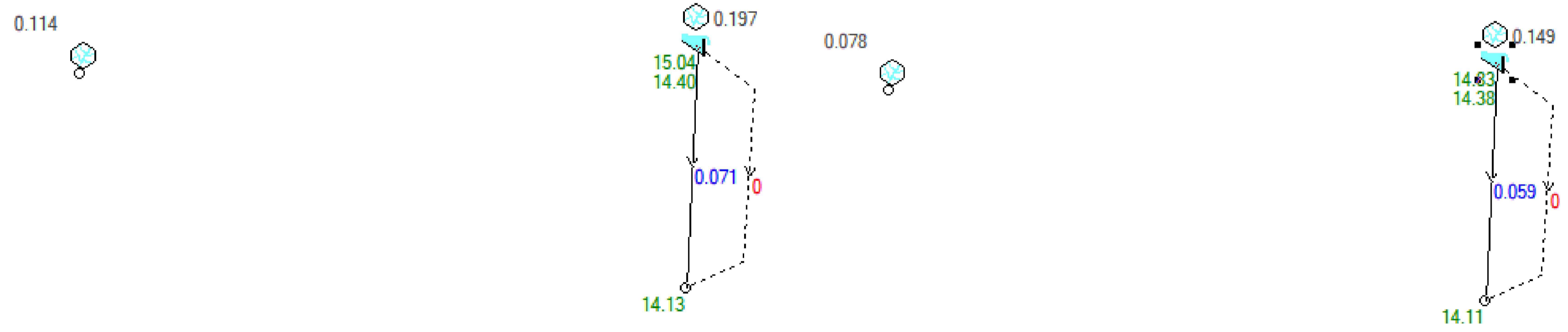

1% AEP DRAINS RESULTS

20% AEP DRAINS RESULTS



ISSUE FOR DA

REVISION	AMENDMENT	ISSUE DATE
C	AMENDED AS PER COUNCIL'S RFI	29-10-2019
B	ISSUED FOR DA	29-11-2018
A	ISSUED FOR COORDINATION	02-07-2018



Phone: (02) 9745 5202  
 Fax: (02) 8004 7461  
 Email: Info@alphaengineering.com.au  
 Address: 24A Burleigh St, Burwood NSW 2134  
 Website: www.alphaengineering.com.au

ARCHITECT  
 Barry Rush & Associates Pty Ltd  
 Architects  
 Suite 25A, 2 Beattie Street, Balmain, NSW, Australia, 2041  
 Phone: (612) 9555 8028 Fax: (612) 9810 0161  
 Email: info@barryrush.com.au  
 www.barryrush.com.au

PROJECT  
 PROPOSED DEVELOPMENT  
 638 PITTWATER ROAD,  
 BROOKVALE

DRAWING TITLE		
OUTLET PIPE LONG SECTION & DRAINS MODEL RESULTS		
SCALES	DESIGNED	DRAFTED
AS SHOWN	DM	PS
DRAWING NO.	APPROVED	REVISION
A8256 - SW05	JM	C

COPYRIGHT THIS DRAWING REMAINS THE PROPERTY OF ALPHA ENGINEERING & DEVELOPMENT AND MAY NOT BE ALTERED IN ANY WAY WITHOUT ALPHA ENGINEERING'S WRITTEN CONSENT

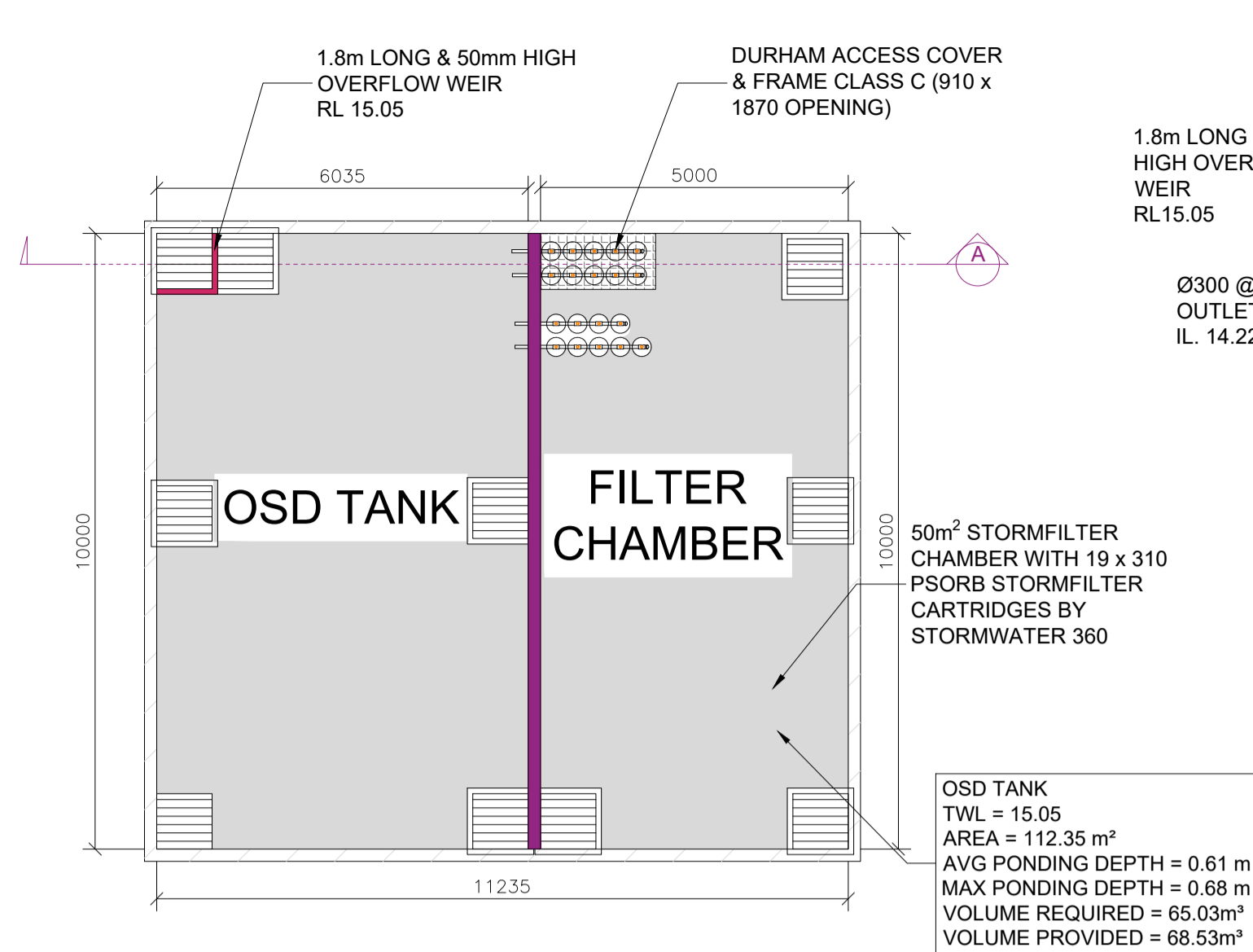

**OSD TANK PLAN**  
1:100 @ A1

OSD TANK  
TWL = 15.05  
AREA = 112.35 m²  
AVG PONDING DEPTH = 0.61 m  
MAX PONDING DEPTH = 0.68 m  
VOLUME REQUIRED = 65.03m³  
VOLUME PROVIDED = 68.53m³

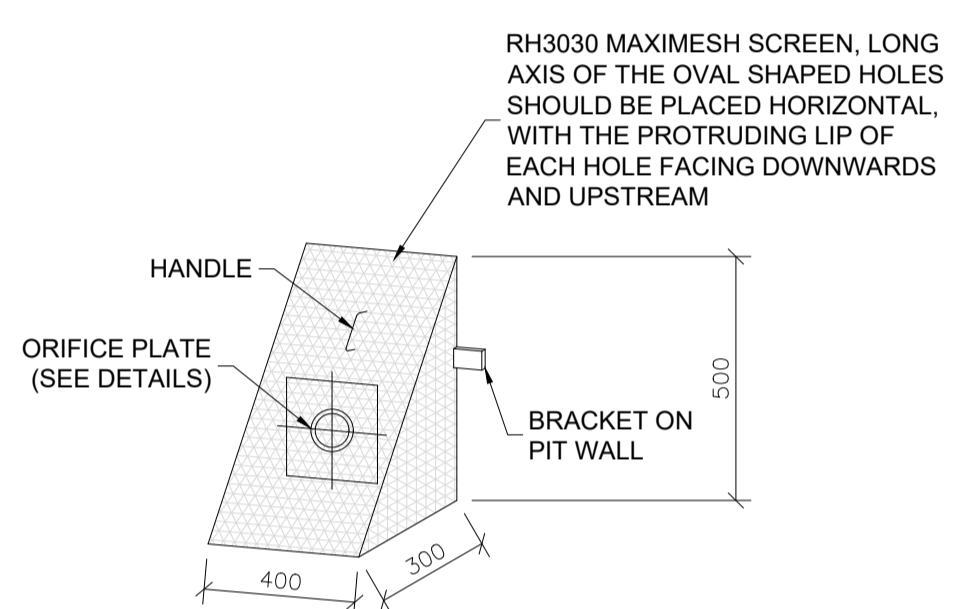

**DETAIL - STANDARD TRASH SCREEN**  
1:20

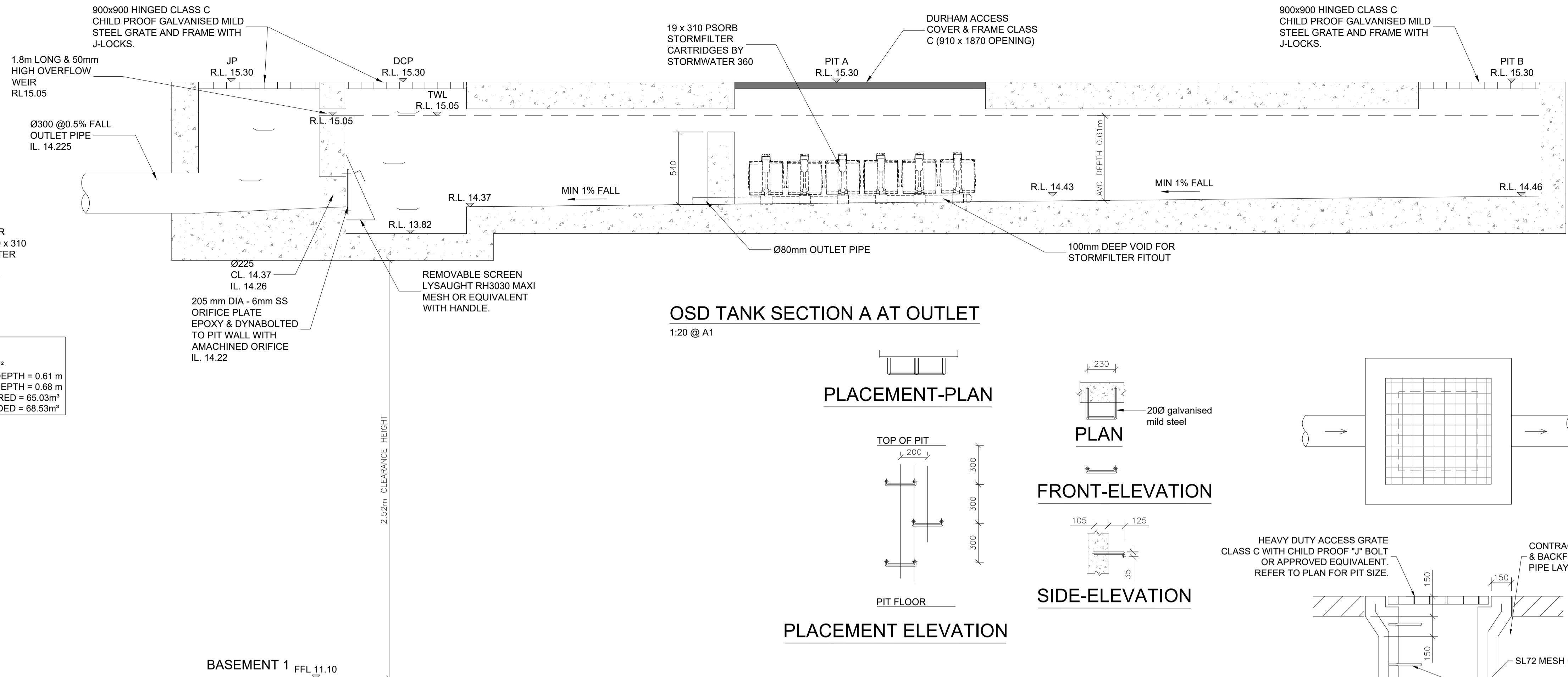

**OSD TANK SECTION A AT OUTLET**  
1:20 @ A1

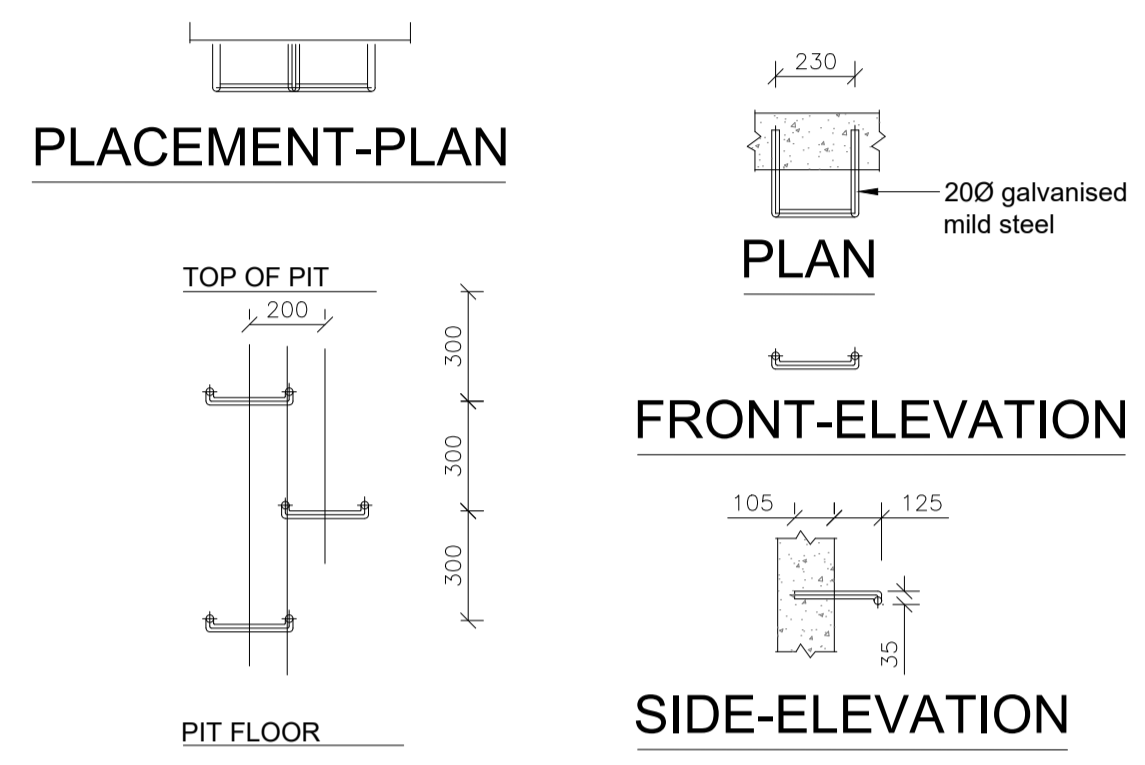

**PLACEMENT ELEVATION**

**TYPICAL STEP IRONS**  
1:20

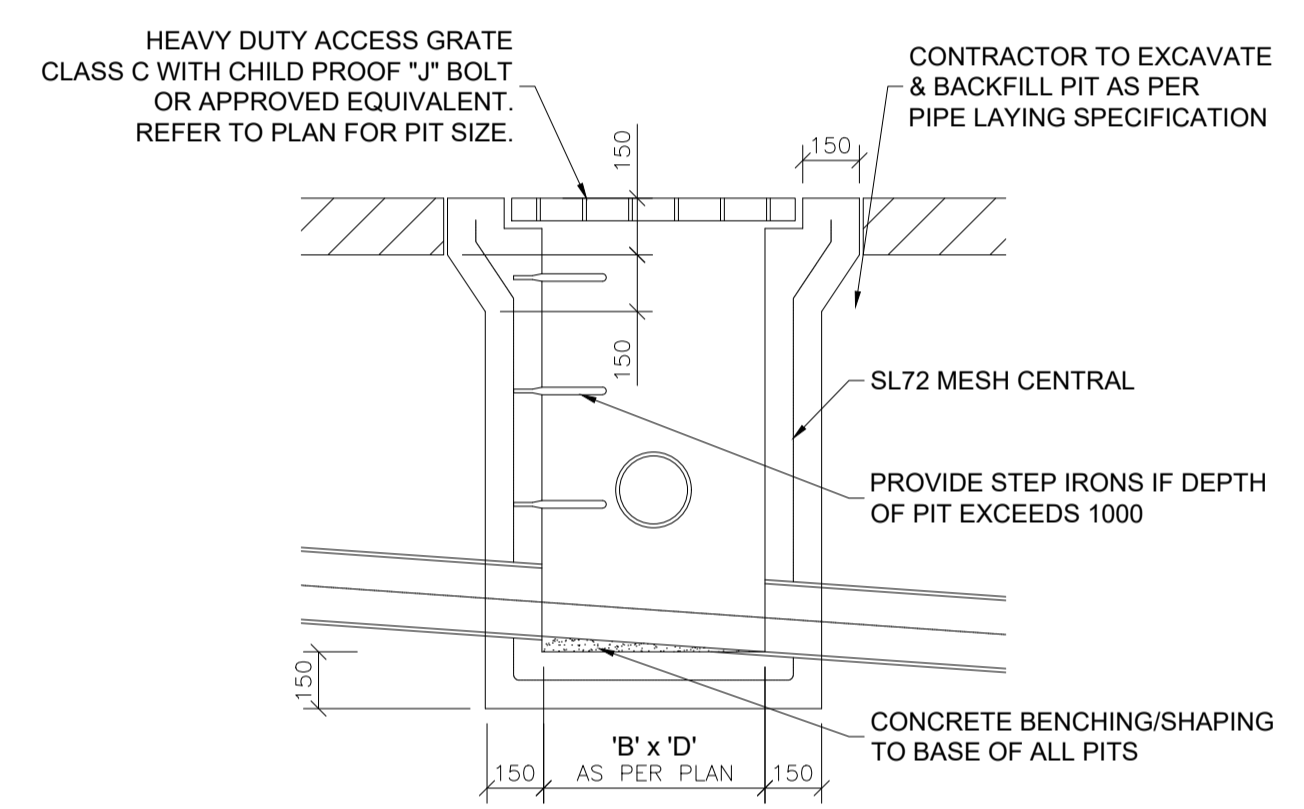

**SECTION - TYPICAL SURFACE INLET PIT**  
1:15 @ A1

TYPICAL FOR ALL PITS IN DRIVEWAY/CARPARK AREAS

THIS IS AN ON-SITE STORMWATER DETENTION SYSTEM REQUIRED BY YOUR LOCAL COUNCIL. IT IS AN OFFENCE TO REDUCE THE VOLUME OF THE TANK OR BASIN OR TO INTERFERE WITH THE ORIFICE PLATE THAT CONTROLS THE OUTFLOW. THE BASE OF THE OUTLET CONTROL PIT AND THE DEBRIS SCREEN MUST BE CLEANED OF DEBRIS AND SEDIMENT ON A REGULAR BASIS BY THE OWNER. THIS PLATE MUST NOT BE REMOVED.

**DETAIL OSD SIGN**  
NTS



**DETAIL - CONFINED SPACE SIGN TO BE PLACED INSIDE OSD TANK & BASEMENT PUMPOUT PIT**  
NTS

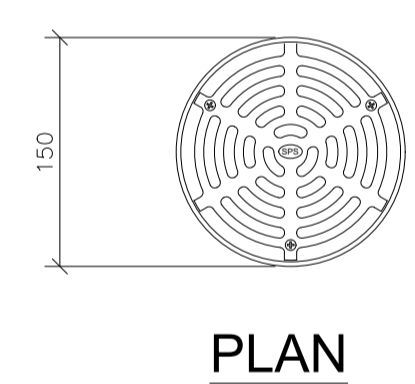

**PLAN**

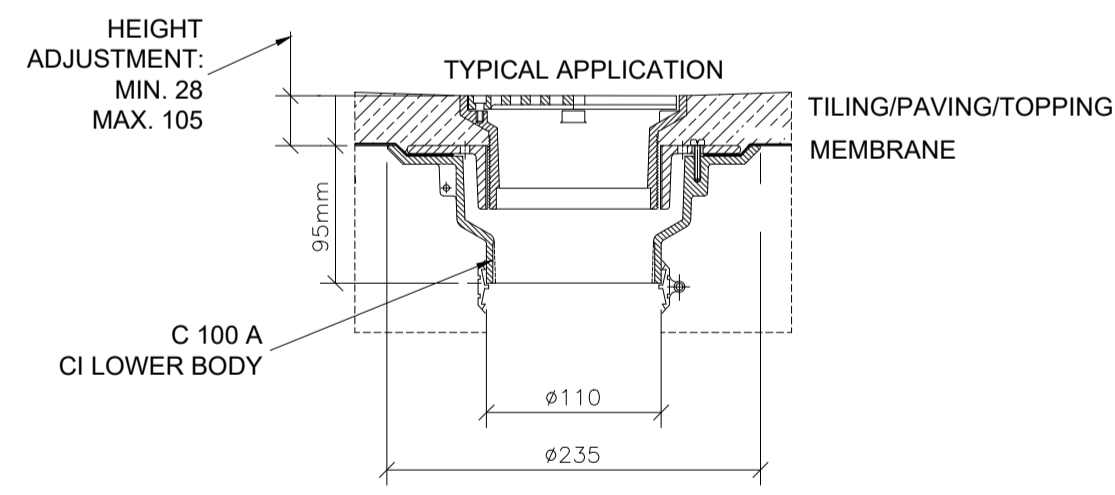

**SECTION - TYPICAL Ø150 FLOOR DRAIN (FD) INLET IN SUSPENDED SLAB**  
1:5 @ A1

SPECIFICATION CODE:  
R150 G/C (BRONZE GRATE, CI LOWER BODY)  
R150N/C (NICKEL - BRONZE GRATE, CI LOWER BODY)  
R150 S/C (316 STAINLESS STEEL GRATE, CI LOWER BODY)

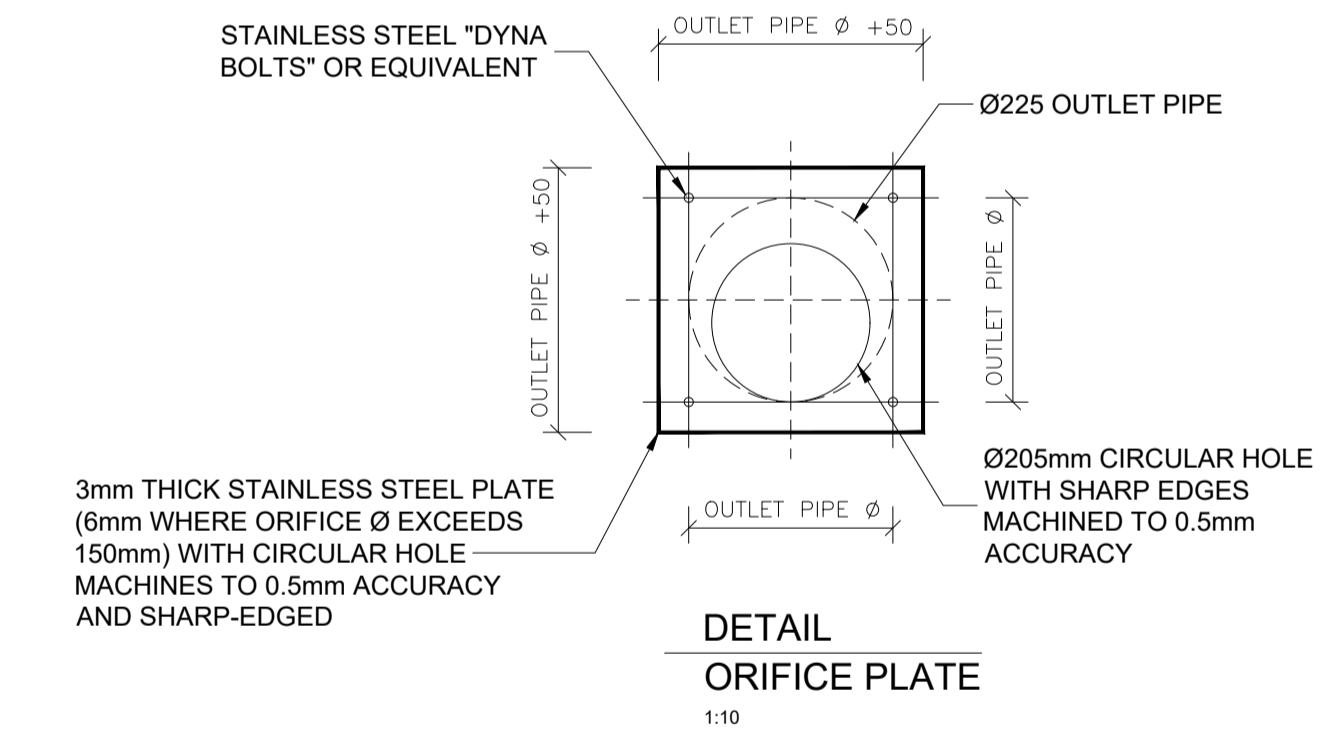

**DETAIL ORIFICE PLATE**  
1:10

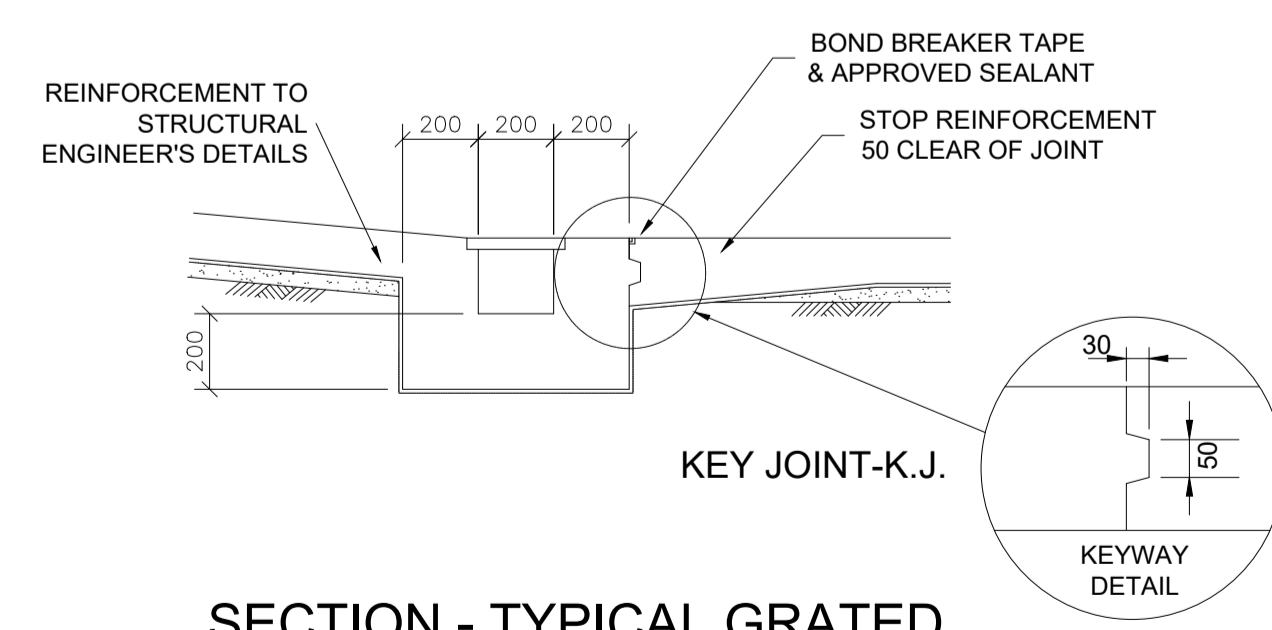

**SECTION - TYPICAL GRATED DRAIN**  
1:20



**ISSUE FOR DA**

REVISION	AMENDMENT	ISSUE DATE
C	AMENDED AS PER COUNCIL'S RFI	29-10-2019
B	ISSUED FOR DA	29-11-2018
A	ISSUED FOR COORDINATION	02-07-2018



Phone: (02) 9745 5202  
Fax: (02) 8004 7461  
Email: Info@alphaengineering.com.au  
Address: 24A Burleigh St, Burwood NSW 2134  
Website: www.alphaengineering.com.au  
COPYRIGHT THIS DRAWING REMAINS THE PROPERTY OF ALPHA ENGINEERING & DEVELOPMENT AND MAY NOT BE ALTERED IN ANY WAY WITHOUT ALPHA ENGINEERING'S WRITTEN CONSENT

**ARCHITECT**  
  
Barry Rush & Associates Pty Ltd  
Architects  
Suite 25A, 2 Beattie Street, Balmain, NSW, Australia, 2041  
Phone: (612) 9555 8028 Fax: (612) 9810 0161  
Email: info@barryrush.com.au  
www.barryrush.com.au

**PROJECT**  
**PROPOSED DEVELOPMENT**  
**638 PITTWATER ROAD,**  
**BROOKVALE**

DRAWING TITLE		
STORMWATER SECTIONS AND DETAILS		
SCALES AS SHOWN	DESIGNED DM	DRAFTED PS
DRAWING NO. A8256 - SW06	APPROVED JM	REVISION C

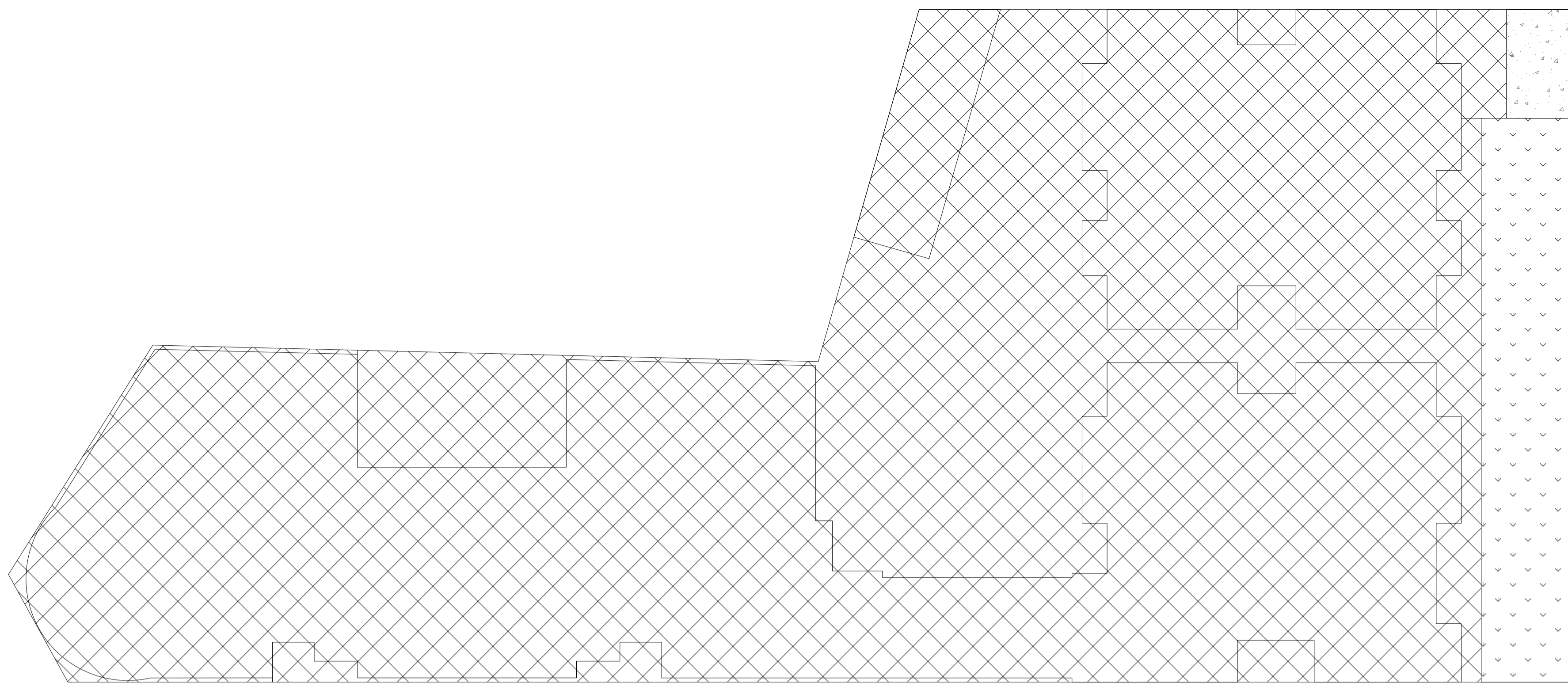

**MUSIC CATCHMENT PLAN**

1:200 @ A1

TOTAL SITE AREA = 2662 m<sup>2</sup>

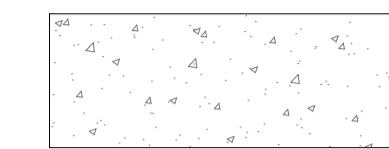

DRIVEWAY AREA = 29.30m<sup>2</sup> (100% IMP.)

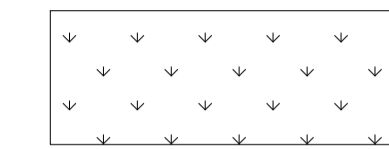

LANDSCAPE AREA = 202.43 m<sup>2</sup> (100% PER.)

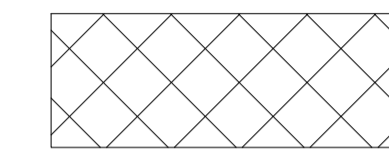

RESIDENTIAL AREA = 2417.55 m<sup>2</sup> (100% IMP.)

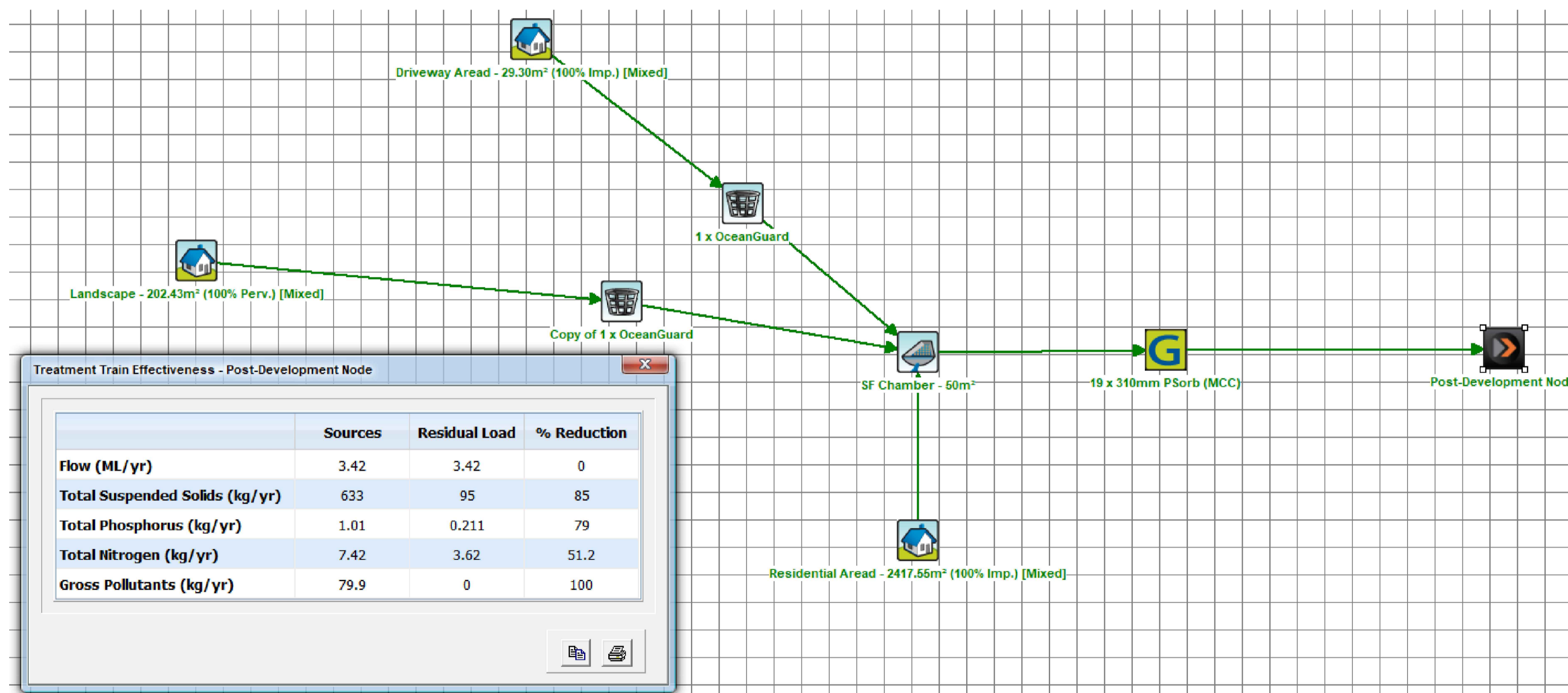

**MUSIC MODEL LAYOUT & RESULTS**

NTS

- SF CHAMBER NODE MODELLED WITH "K" VALUE SET TO 1

**Table 4 – General Stormwater Quality Requirements**

Pollutant	Performance Requirements
Total Phosphorous	65% reduction in the post development mean annual load <sup>1</sup>
Total Nitrogen	45% reduction in the post development mean annual load <sup>1</sup>
Total Suspended Solids	85% reduction in the post development mean annual load <sup>1</sup>
Gross Pollutants	90% reduction in the post development mean annual load <sup>1</sup> (for pollutants greater than 5mm in diameter)
pH	6.5 - 8.5
Hydrology	The post-development peak discharge must not exceed the pre-development peak discharge for flows up to the 2 year ARI

WSUD REQUIREMENT

NTS

[www.dialbeforeyoudig.com.au](http://www.dialbeforeyoudig.com.au)



**ISSUE FOR DA**

REVISION	AMENDMENT	ISSUE DATE
C	AMENDED AS PER COUNCIL'S RFI	29-10-2019
B	ISSUED FOR DA	29-11-2018
A	ISSUED FOR COORDINATION	02-07-2018



Phone: (02) 9745 5202  
 Fax: (02) 8004 7461  
 Email: [Info@alphaengineering.com.au](mailto:Info@alphaengineering.com.au)  
 Address: 24A Burleigh St,  
 Burwood NSW 2134  
 Website: [www.alphaengineering.com.au](http://www.alphaengineering.com.au)

COPYRIGHT THIS DRAWING REMAINS THE PROPERTY OF ALPHA ENGINEERING & DEVELOPMENT AND MAY NOT BE ALTERED IN ANY WAY WITHOUT ALPHA ENGINEERING'S WRITTEN CONSENT

**ARCHITECT**  
  
**Barry Rush & Associates Pty Ltd**  
 Architects  
 Suite 25A, 2 Beattie Street, Balmain,  
 NSW, Australia, 2041  
 Phone: (612) 9555 8028 Fax: (612) 9810 0161  
 Email: [info@baryrush.com.au](mailto:info@baryrush.com.au)  
[www.baryrush.com.au](http://www.baryrush.com.au)

**PROJECT**  
 PROPOSED DEVELOPMENT  
 638 PITTWATER ROAD,  
 BROOKVALE

DRAWING TITLE		
WATER SENSITIVE URBANE DESIGN		
SCALES	DESIGNED	DRAFTED
AS SHOWN	DM	PS
DRAWING NO.	APPROVED	REVISION
A8256 - SW07	JM	C