

# PROPOSED CIVIL PLANS

at: 27-29 NORTH AVALON ROAD, AVALON

for: ARMADA AVALON PTY LTD

Architect: ENVIRONA STUDIO

Prepared By:

**NB Consulting Engineers**  
STRUCTURAL - CIVIL - STORMWATER - REMEDIAL  
A.C.N. 076 121 616 A.B.N. 24 076 121 616

Sydney: Ph: (02) 9984 7000 Fax: (02) 9984 7444  
Suite 207, 30 Fisher Road Dee Why N.S.W. 2099

Gold Coast: Ph: (07) 5631 4744

Unit 8, 1726 Gold Coast Highway Burleigh Heads QLD 4220

E : nb@nbconsulting.com.au W : www.nbconsulting.com.au

The copyright of these drawings remains with Northern Beaches Consulting Engineers Pty Ltd. Trading as NB Consulting Engineers

#### DRAWING SCHEDULE:

C01 - CIVIL ACCESS PLAN - SHEET 1  
C02 - CIVIL ACCESS PLAN - SHEET 2  
C03 - LONGITUDINAL SECTIONS - SHEET 1  
C04 - LONGITUDINAL SECTIONS - SHEET 2  
C05 - LONGITUDINAL SECTIONS - SHEET 3  
C06 - SECTIONS & DETAILS

ISSUED FOR D.A.  
SUBMISSION ONLY  
NOT FOR  
CONSTRUCTION

NB Consulting Engineers

190247

REV B - 20/09/2019



**CIVIL NOTES:**

- FOR EXISTING CONTOURS AND LEVELS. REFER SURVEY PLAN. ALL LEVELS AND DIMENSIONS TO BE CONFIRMED PRIOR TO CONSTRUCTION.
- PRIOR APPROVAL MAY BE REQUIRED WITH RELEVANT AUTHORITIES PRIOR TO RETAINING WALLS, SHORING, BATTERS & DRAINAGE IMPACTING NEIGHBORING PROPERTIES AND INFRASTRUCTURE BEYOND BOUNDARIES.
- STORMWATER AND DRAINAGE BY OTHERS TO AS3500.
- ALL BATTERS, RETAINING WALLS AND BULK EARTHWORKS TO FUTURE DETAILS BY OTHERS. ALL RETAINING WALLS GREATER THAN 900mm HIGH TO BE DESIGNED BY A QUALIFIED ENGINEER.
- EXISTING DRAINAGE ACROSS NATURE STRIP & KERBS IMPACTING PROPOSED WORKS TO BE RELOCATED OR UPGRADED AS REQUIRED BY OTHERS TO COUNCIL SPECIFICATIONS.
- NATURE STRIP PAVEMENT, GUTTER & FOOTWAY CROSSINGS TO COUNCIL SPECIFICATIONS.
- CONCRETE DRIVEWAY & JOINTING PLAN BY OTHERS.
- IMPACT OF PROPOSED WORKS ON EXISTING TREE/S. WHERE NECESSARY REFER TO ARBORIST FOR REQUIREMENTS.
- MINIMUM DRIVEWAY WIDTHS, CLEARANCES, INCLUDING HEAD CLEARANCES TO COMPLY WITH AS2890.1
- TRAFFIC CONTROL SIGNAGE AND TRAFFIC CONTROL MEASURES BY OTHERS.
- LINE AND MARKINGS BY OTHERS TO CONFORM TO MAIN ROADS MANUAL OF UNIFORM TRAFFIC CONTROL DEVICES.
- ANY CHANGES TO THE PROPOSED WORKS TO BE CONFIRMED WITH NB CONSULTING PRIOR TO COMMENCING CONSTRUCTION.
- COUNCIL APPROVAL MAY BE REQUIRED PRIOR TO COMMENCING CONSTRUCTION.
- ANY VEHICLE PROFILE ANALYSIS SUCH AS THE B05 PROFILE IS NORMALLY UNDERTAKEN ALONG THE DETAILED LONGITUDINAL SECTIONS, WHICH HAVE GENERALLY BEEN LOCATED IN ACCORDANCE WITH COUNCIL POLICY. UNLESS NOTED OTHERWISE, THIS MAY NOT NECESSARILY REPRESENT THE WORSE CASE ANALYSIS.

PROPOSED CONTOUR LEVELS ARE INDICATIVE ONLY. ALL LEVELS TO BE CONFIRMED PRIOR TO CONSTRUCTION. DO NOT SCALE.

- NO SWEEP PATH ANALYSIS HAS BEEN UNDERTAKEN AND/OR HAS BEEN PROVIDED FOR THIS DEVELOPMENT.
- BARRIERS REQUIRED WHERE DRIVEWAY DROP EXCEEDS 600mm. WHEEL STOP REQUIRED WHERE DRIVEWAY DROP IS BETWEEN 150-600mm. REFER AS2890.1.

**LEGEND:**



**CADASTRAL REFERENCE MARKS, SURVEY PMs OR SSMs**

1) PURSUANT TO THE SURVEYING AND SPATIAL INFORMATION ACT, ANY CADASTRAL REFERENCE MARKS, SURVEY PMs OR SSMs THAT ARE ON KERBS, FOOTPATHS OR SIMILAR THAT MAY BE AFFECTED BY CONSTRUCTION OR MAINTENANCE, NEED TO BE IDENTIFIED AND SURVEYED BY A REGISTERED LAND SURVEYOR BEFORE THEY ARE DESTROYED OR DISTURBED. PERSONAL FINES APPLY FOR BREACHES OF THE ACT.



NO INVESTIGATION OF UNDERGROUND SERVICES HAS BEEN MADE. ALL RELEVANT AUTHORITIES SHOULD BE NOTIFIED PRIOR TO ANY EXCAVATION ON OR NEAR THE SITE. DEVELOPERS & EXCAVATORS MAY BE HELD FINANCIALLY RESPONSIBLE BY THE ASSET OWNER SHOULD THEY DAMAGE UNDERGROUND NETWORKS.

**CARELESS DIGGING CAN:**  
 - CAUSE DEATH OR SERIOUS INJURY TO WORKERS AND THE GENERAL PUBLIC  
 - INCONVENIENCE USERS OF ELECTRICITY, GAS, WATER AND COMMUNICATIONS  
 - LEAD TO CRIMINAL PROSECUTION AND DAMAGES CLAIMS  
 - CAUSE EXPENSIVE FINANCIAL LOSSES TO BUSINESS  
 - CUT OFF EMERGENCY SERVICES  
 - DELAY PROJECT COMPLETION TIMES WHILE THE DAMAGE IS REPAIRED

MINIMISE YOUR RISK AND DIAL BEFORE YOU DIG. - TEL. 1100

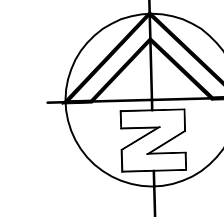

**NOTES:**

- ALL DIMENSIONS TO BE VERIFIED ON SITE BY BUILDER BEFORE COMMENCING WITH WORK.

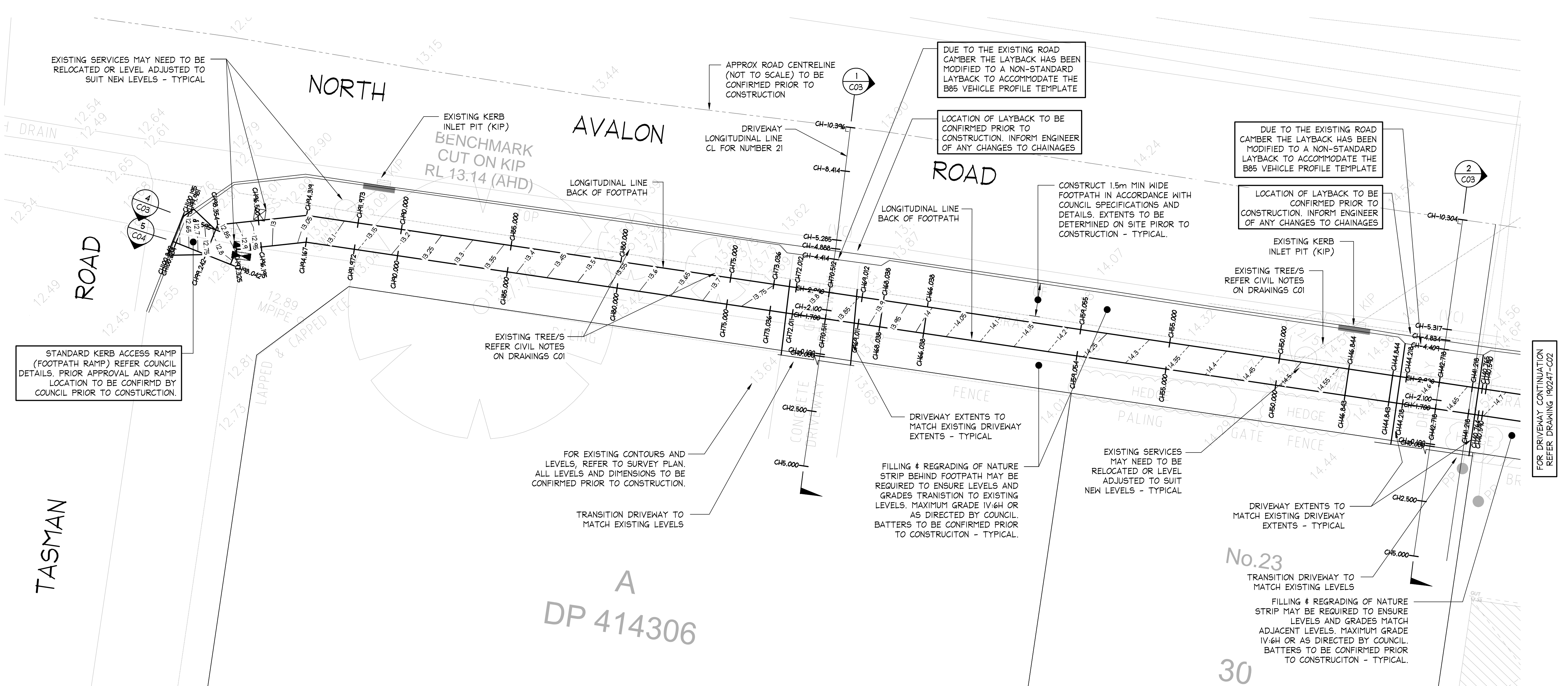

**CIVIL ACCESS PLAN**  
SCALE = 1 : 100

ISSUED FOR D.A. SUBMISSION ONLY NOT FOR CONSTRUCTION

IF IN DOUBT ASK

AI		DOCUMENT CERTIFICATION		NB Consulting Engineers STRUCTURAL - CIVIL - STORMWATER - REMEDIAL A.C.N. 076 121 616 A.B.N. 24 076 121 616 Sydney: Ph: (02) 9984 7000 Fax: (02) 9984 7444 Suite 207, 30 Fisher Road Dee Why N.S.W. 2099 Gold Coast: Ph: (07) 5631 4744 Unit 8, 1726 Gold Coast Highway Burleigh Heads QLD 4220 E: nb@nbconsulting.com.au W: www.nbconsulting.com.au		Architect: <b>ENVIRONA STUDIO</b>		Project: <b>PROPOSED CIVIL PLANS AT 27-29 NORTH AVALON RD, AVALON</b>		Date: AUG 2019	Design: D.K.	Drawn: D.K.
Date:	Issue:	Description:	By:	Review:	Client: <b>ARMADA AVALON PTY LTD</b>			Drawing Title: <b>CIVIL ACCESS PLANS - SHEET 1</b>		Job No: <b>190247</b>	Drawing No: <b>C01</b>	Issue: <b>B</b>
20/09/2019	B	REVISED PLANS	D.K.	M.W.	Architect: <b>ENVIRONA STUDIO</b>			Project: <b>PROPOSED CIVIL PLANS AT 27-29 NORTH AVALON RD, AVALON</b>		Date: AUG 2019	Design: D.K.	Drawn: D.K.
19/09/2019	A	ISSUED FOR DA SUBMISSION ONLY - NOT FOR CONSTRUCTION	D.K.	M.W.	Client: <b>ARMADA AVALON PTY LTD</b>			Drawing Title: <b>CIVIL ACCESS PLANS - SHEET 1</b>		Job No: <b>190247</b>	Drawing No: <b>C01</b>	Issue: <b>B</b>

NB Consulting Engineers



**CIVIL NOTES:**

- FOR EXISTING CONTOURS AND LEVELS. REFER SURVEY PLAN. ALL LEVELS AND DIMENSIONS TO BE CONFIRMED PRIOR TO CONSTRUCTION.
- PRIOR APPROVAL MAY BE REQUIRED WITH RELEVANT AUTHORITIES PRIOR TO RETAINING WALLS, SHORING, BATTERS & DRAINAGE IMPACTING NEIGHBORING PROPERTIES AND INFRASTRUCTURE BEYOND BOUNDARIES.
- STORMWATER AND DRAINAGE BY OTHERS TO AS3500.
- ALL BATTERS, RETAINING WALLS AND BULK EARTHWORKS TO FUTURE DETAILS BY OTHERS. ALL RETAINING WALLS GREATER THAN 900mm HIGH TO BE DESIGNED BY A QUALIFIED ENGINEER.
- EXISTING DRAINAGE ACROSS NATURE STRIP & KERBS IMPACTING PROPOSED WORKS TO BE RELOCATED OR UPGRADED AS REQUIRED BY OTHERS TO COUNCIL SPECIFICATIONS.
- NATURE STRIP PAVEMENT, GUTTER & FOOTWAY CROSSINGS TO COUNCIL SPECIFICATIONS.
- CONCRETE DRIVEWAY & JOINTING PLAN BY OTHERS.
- IMPACT OF PROPOSED WORKS ON EXISTING TREE/S. WHERE NECESSARY REFER TO ARBORIST FOR REQUIREMENTS.
- MINIMUM DRIVEWAY WIDTHS, CLEARANCES, INCLUDING HEAD CLEARANCES TO COMPLY WITH AS2890.1
- TRAFFIC CONTROL SIGNAGE AND TRAFFIC CONTROL MEASURES BY OTHERS.
- LINE AND MARKINGS BY OTHERS TO CONFORM TO MAIN ROADS MANUAL OF UNIFORM TRAFFIC CONTROL DEVICES.
- ANY CHANGES TO THE PROPOSED WORKS TO BE CONFIRMED WITH NB CONSULTING.
- COUNCIL APPROVAL MAY BE REQUIRED PRIOR TO COMMENCING CONSTRUCTION.
- ANY VEHICLE PROFILE ANALYSIS SUCH AS THE B85 PROFILE IS NORMALLY UNDERTAKEN ALONG THE DETAILED LONGITUDINAL SECTIONS, WHICH HAVE GENERALLY BEEN LOCATED IN ACCORDANCE WITH COUNCIL POLICY, UNLESS NOTED OTHERWISE. THIS MAY NOT NECESSARILY REPRESENT THE WORSE CASE ANALYSIS.

- NO SWEEP PATH ANALYSIS HAS BEEN UNDERTAKEN AND/OR HAS BEEN PROVIDED FOR THIS DEVELOPMENT.
- BARRIERS REQUIRED WHERE DRIVEWAY DROP EXCEEDS 600mm. WHEEL STOP REQUIRED WHERE DRIVEWAY DROP IS BETWEEN 150-600mm. REFER AS2890.1.

PROPOSED CONTOUR LEVELS ARE INDICATIVE ONLY. ALL LEVELS TO BE CONFIRMED PRIOR TO CONSTRUCTION. DO NOT SCALE.

**LEGEND:**

- CHAINAGES
- PROPOSED DRIVEWAY/FOOTPATH OUTLINE

**CADASTRAL REFERENCE MARKS, SURVEY PMs OR SSMs**

1) PURSUANT TO THE SURVEYING AND SPATIAL INFORMATION ACT, ANY CADASTRAL REFERENCE MARKS, SURVEY PMs OR SSMs THAT ARE ON KERBS, FOOTPATHS OR SIMILAR THAT MAY BE AFFECTED BY CONSTRUCTION OR MAINTENANCE, NEED TO BE IDENTIFIED AND SURVEYED BY A REGISTERED LAND SURVEYOR BEFORE THEY ARE DESTROYED OR DISTURBED, PERSONAL FINES APPLY FOR BREACHES OF THE ACT.



NO INVESTIGATION OF UNDERGROUND SERVICES HAS BEEN MADE. ALL RELEVANT AUTHORITIES SHOULD BE NOTIFIED PRIOR TO ANY EXCAVATION ON OR NEAR THE SITE. DEVELOPERS & EXCAVATORS MAY BE HELD FINANCIALLY RESPONSIBLE BY THE ASSET OWNER SHOULD THEY DAMAGE UNDERGROUND NETWORKS.

CARELESS DIGGING CAN:  
 - CAUSE DEATH OR SERIOUS INJURY TO WORKERS AND THE GENERAL PUBLIC  
 - INCONVENIENCE USERS OF ELECTRICITY, GAS, WATER AND COMMUNICATIONS  
 - LEAD TO CRIMINAL PROSECUTION AND DAMAGES CLAIMS  
 - CAUSE EXPENSIVE FINANCIAL LOSSES TO BUSINESS  
 - CUT OFF EMERGENCY SERVICES  
 - DELAY PROJECT COMPLETION TIMES WHILE THE DAMAGE IS REPAIRED

MINIMISE YOUR RISK AND DIAL BEFORE YOU DIG. - TEL. 1100

**NOTES:**

- ALL DIMENSIONS TO BE VERIFIED ON SITE BY BUILDER BEFORE COMMENCING WITH WORK.

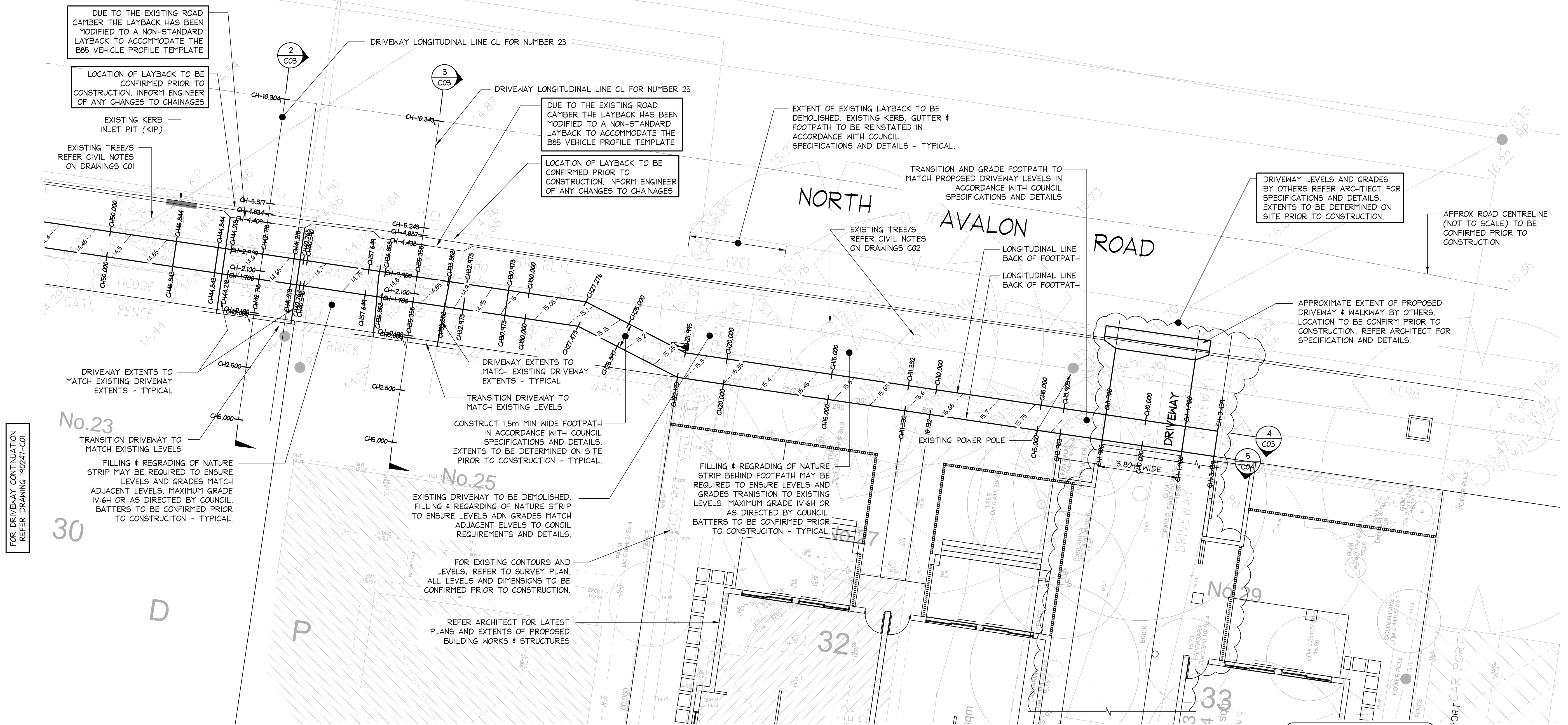
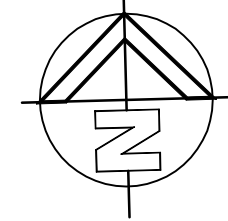

**CIVIL ACCESS PLAN**  
SCALE = 1 : 100

ISSUED FOR D.A. SUBMISSION ONLY NOT FOR CONSTRUCTION

IF IN DOUBT ASK

AI		DOCUMENT CERTIFICATION		NB Consulting Engineers STRUCTURAL - CIVIL - STORMWATER - REMEDIAL A.C.N. 076 121 616 A.B.N. 24 076 121 616 Sydney: Ph: (02) 9984 7000 Fax: (02) 9984 7444 Suite 207, 30 Fisher Road Dee Why N.S.W. 2099 Gold Coast: Ph: (07) 5631 4744 Unit 8, 1726 Gold Coast Highway Burleigh Heads QLD 4220 E : nb@nbconsulting.com.au W : www.nbconsulting.com.au		Architect: ENVIRONA STUDIO		Project: PROPOSED CIVIL PLANS AT 27-29 NORTH AVALON RD, AVALON		Date: AUG 2019	Design: D.K.	Drawn: D.K.
Date:	Issue:	Description:	By:	Review:		Client: ARMADA AVALON PTY LTD	Drawing Title: CIVIL ACCESS PLANS - SHEET 2	Job No: 190247	Drawing No: C02	Issue: B		
20/09/2019	B	REVISED PLANS	D.K.	M.W.	Rick G Wray							
19/09/2019	A	ISSUED FOR DA SUBMISSION ONLY - NOT FOR CONSTRUCTION	D.K.	M.W.	BE(Civil), CP(Eng, MIE Aust.), NER, RPEQ: 08293. (Director NB Consulting Engineers)							

NB Consulting Engineers



**B85 PROFILE:**

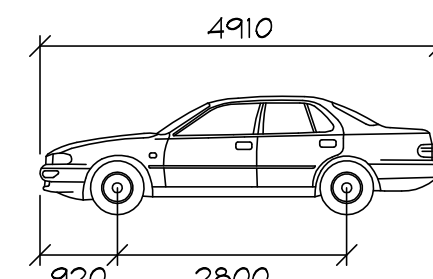

Width	: 1870
Track	: 1770
Lack to Lock Time	: 6.0
Steering Angle	: 34.1

**NOTES:**

1. ALL DIMENSIONS TO BE VERIFIED ON SITE BY BUILDER BEFORE COMMENCING WITH WORK.
2. FOR GENERAL NOTES REFER TO DRAWING NUMBER: C01.

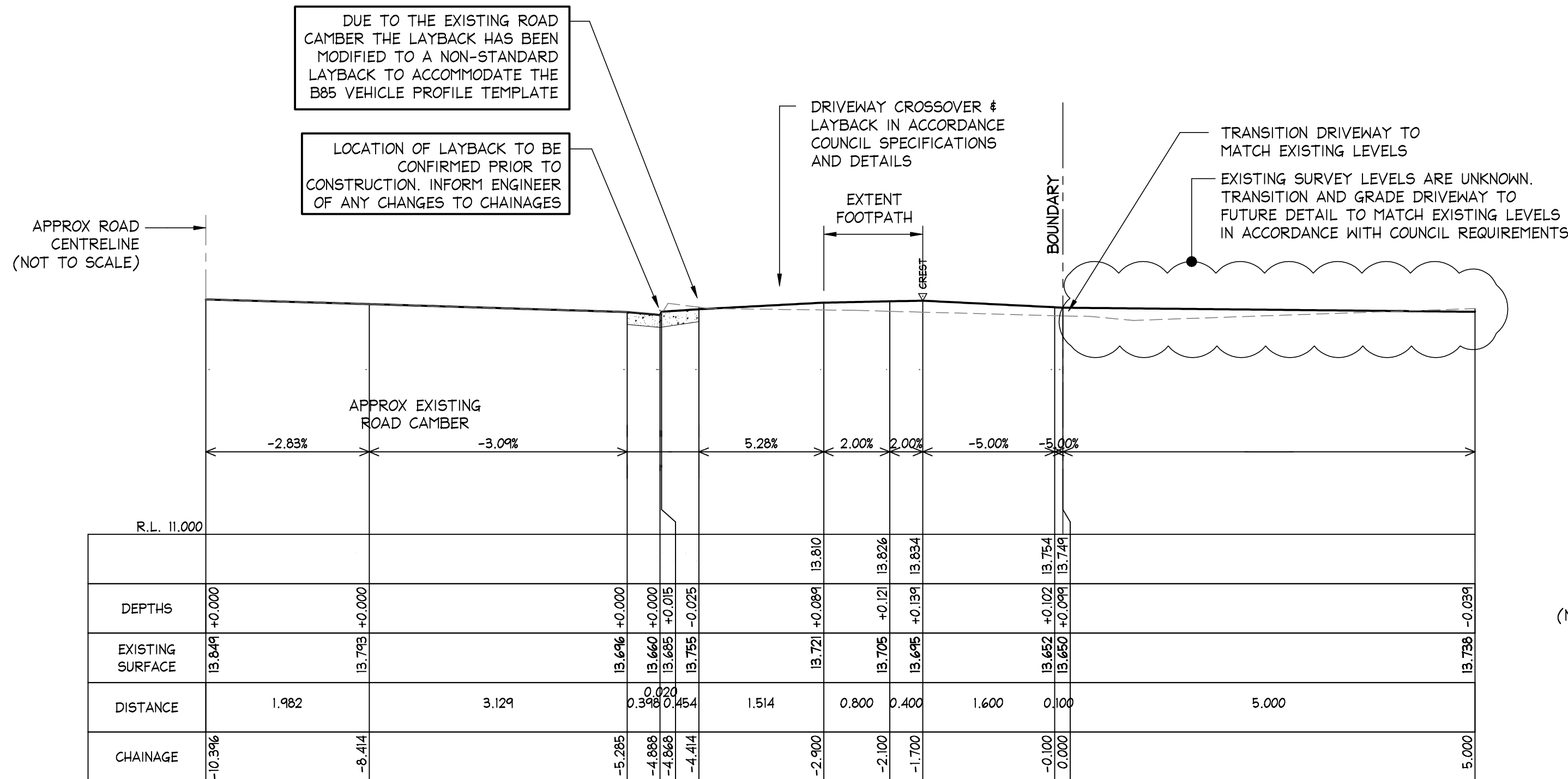

LONGITUDINAL SECTION DRIVEWAY CL FOR No.21  
FROM CH: -10.396 TO CH: 5.000  
SCALES: HORIZONTAL 1:50 VERTICAL 1:50

SECTION 1 C01

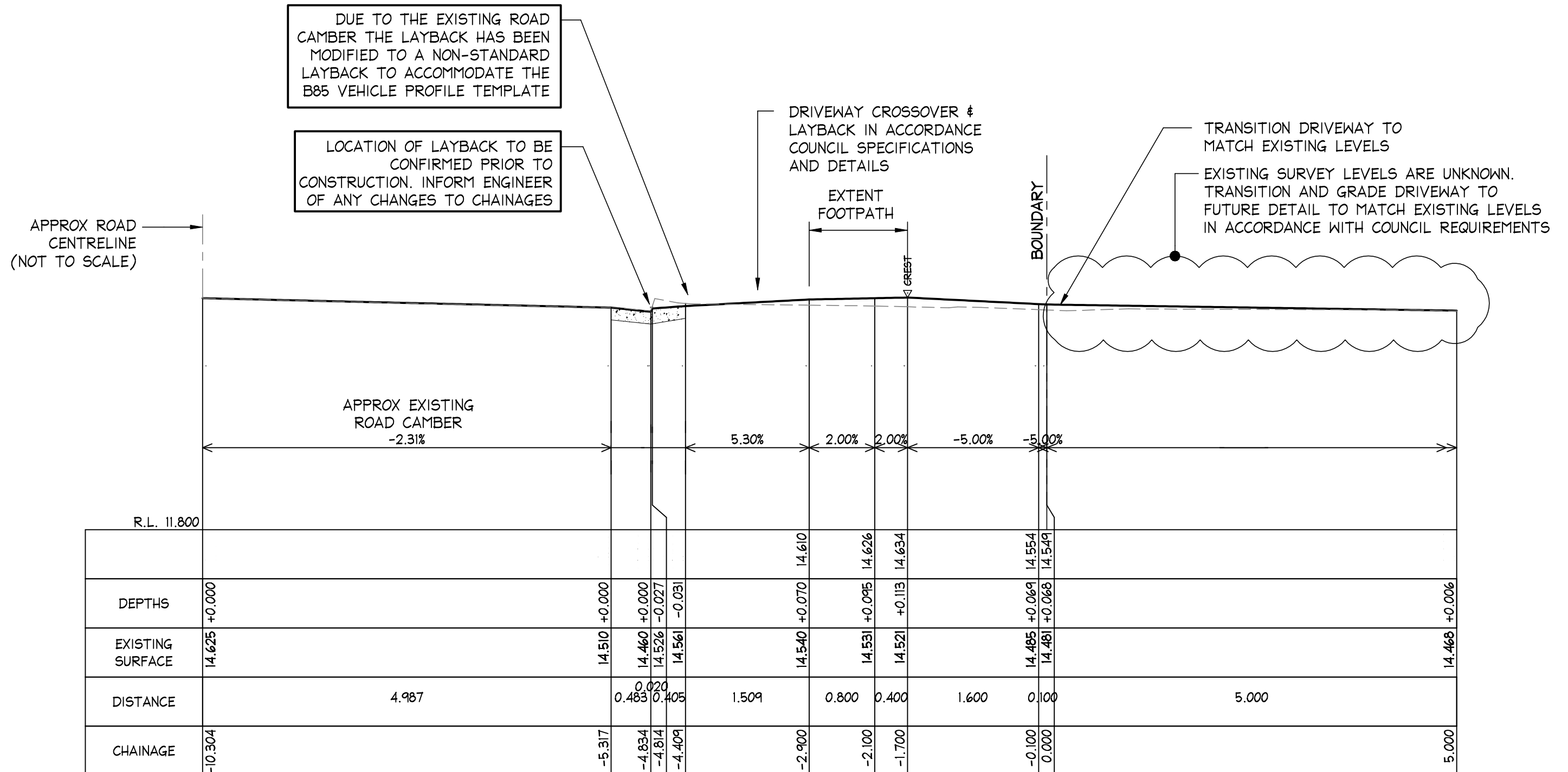

LONGITUDINAL SECTION DRIVEWAY CL FOR No.23  
FROM CH: -10.304 TO CH: 5.000  
SCALES: HORIZONTAL 1:50 VERTICAL 1:50

SECTION 2 C01, C02

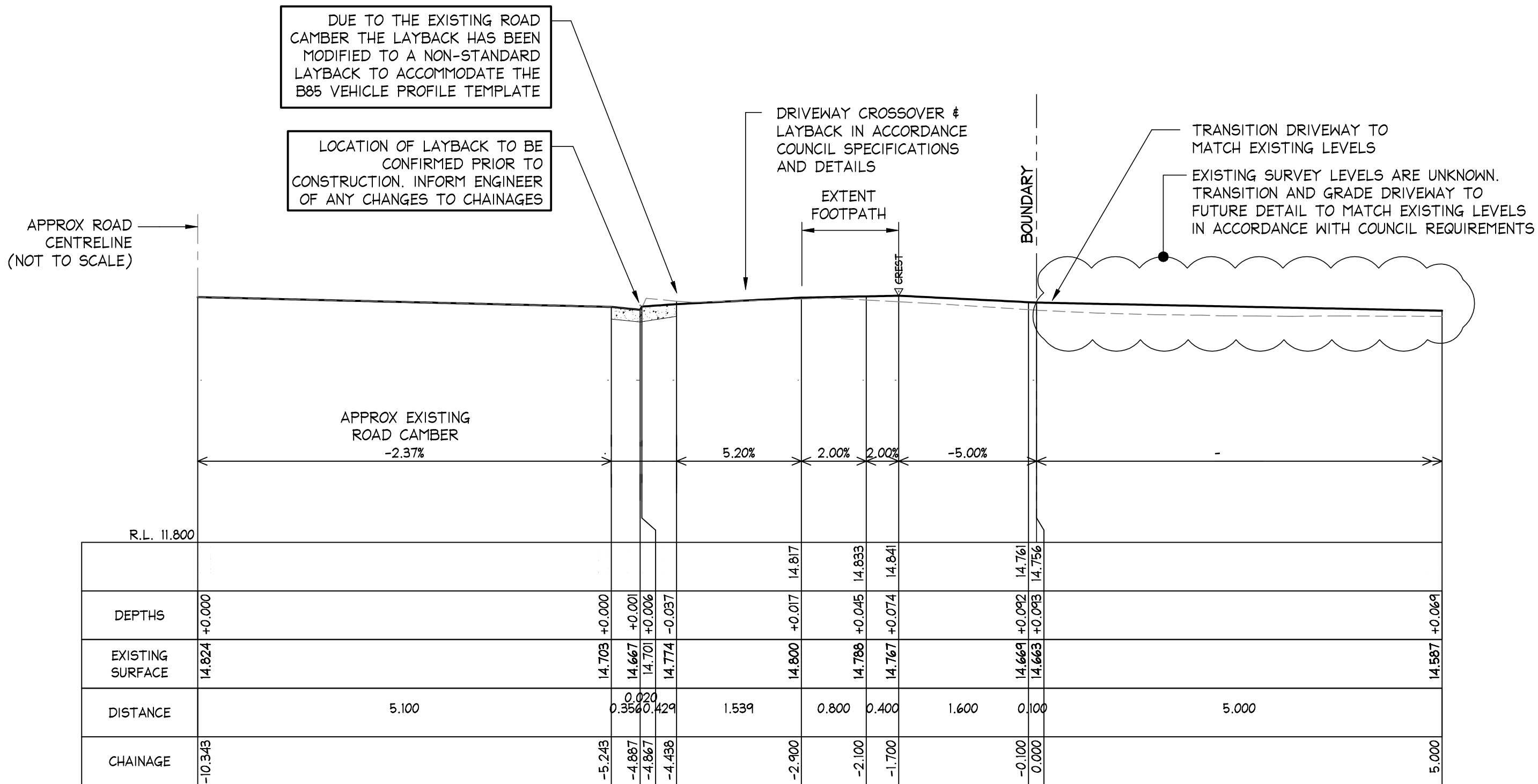

LONGITUDINAL SECTION DRIVEWAY CL FOR No.25  
FROM CH: -10.343 TO CH: 5.000  
SCALES: HORIZONTAL 1:50 VERTICAL 1:50

SECTION 3 C02

ISSUED FOR D.A. SUBMISSION ONLY  
NOT FOR CONSTRUCTION

IF IN DOUBT ASK

AI

DOCUMENT CERTIFICATION			NB Consulting Engineers STRUCTURAL - CIVIL - STORMWATER - REMEDIAL A.C.N. 076 121 616 A.B.N. 24 076 121 616			Architect: ENVIRONA STUDIO		Project: PROPOSED CIVIL PLANS AT 27-29 NORTH AVALON RD, AVALON		Date: AUG 2019	Design: D.K.	Drawn: D.K.
Date: 20/09/2019			By: Rick G Wray			Client: ARMADA AVALON PTY LTD		Drawing Title: LONGITUDINAL SECTIONS - SHEET 1		Job No: 190247	Drawing No: C03	Issue: B
Description: REVISED PLANS			Reviewed: M.W.			Sydney: Ph: (02) 9984 7000 Fax: (02) 9984 7444		Gold Coast: Ph: (07) 5631 4744		The copyright of this drawing remains with Northern Beaches Consulting Engineers Pty Ltd. Trading as NB Consulting Engineers		

**BACK OF KERB SURVEY LEVEL NOTE**

BACK OF KERB LEVELS HAVE BEEN INTERPOLATED FROM EXISTING TOP OF KERB (TOK) LEVELS. ALL LEVELS TO BE CONFIRMED PRIOR TO CONSTRUCTION.

**NOTES:**

1. ALL DIMENSIONS TO BE VERIFIED ON SITE BY BUILDER BEFORE COMMENCING WITH WORK.
2. FOR GENERAL NOTES REFER TO DRAWING NUMBER: C01.

www.dialbeforeyoudig.com.au



**B85 PROFILE:**

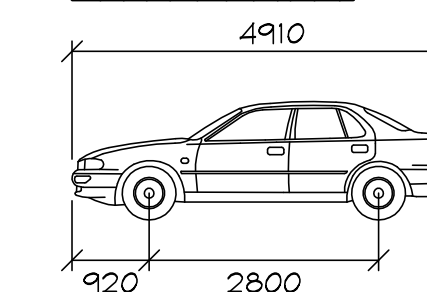

Width : 1870  
Track : 1770  
Lock to Lock Time : 6.0  
Steering Angle : 34.1

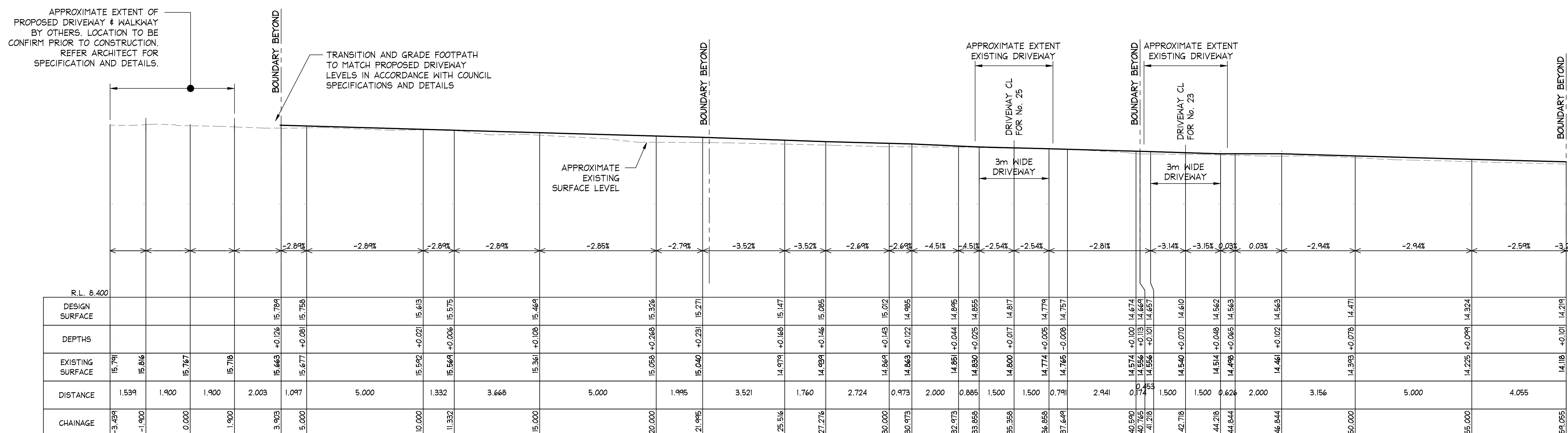

LONGITUDINAL SECTION ALONG BACK OF FOOTPATH FROM CH: -3.439 TO CH: 59.055

SCALES: HORIZONTAL 1:100 VERTICAL 1:100

SECTION 4 C02

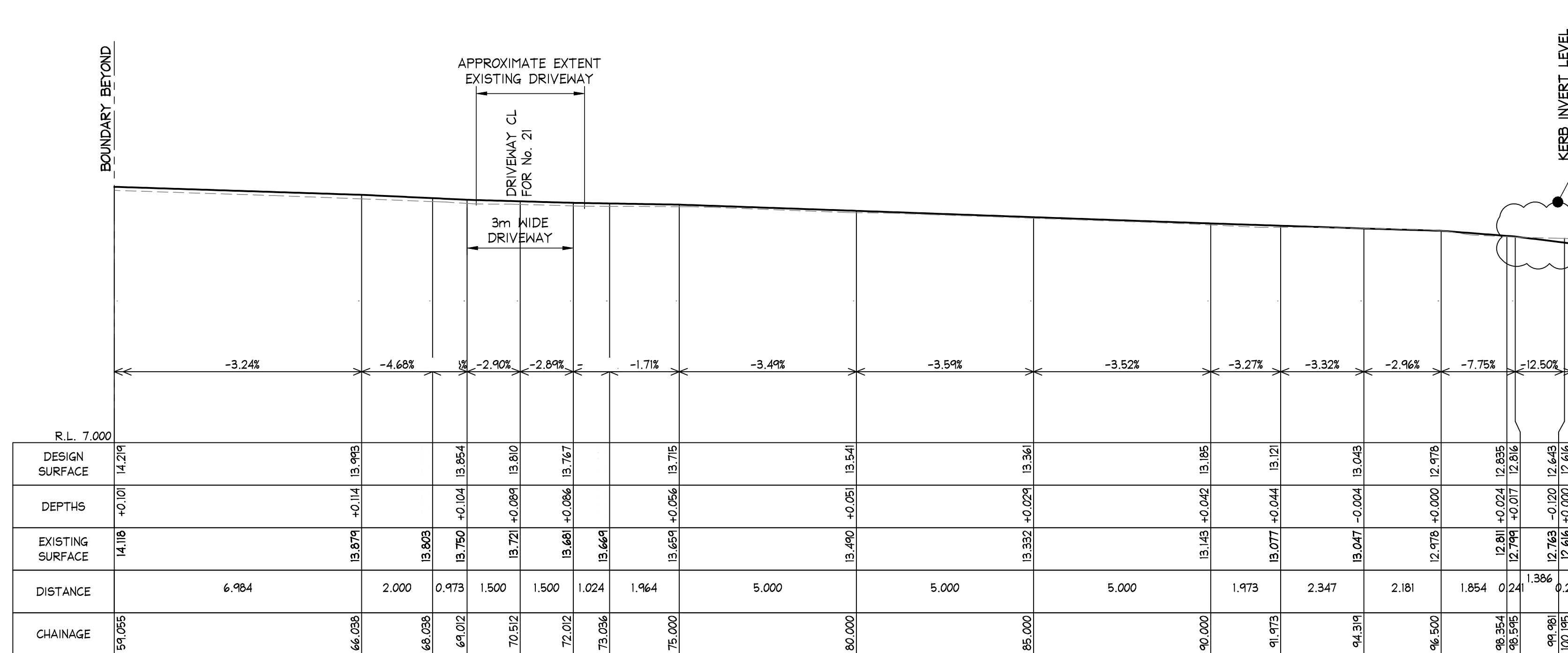

LONGITUDINAL SECTION ALONG BACK OF FOOTPATH FROM CH: 59.055 TO CH: 100.195

SCALES: HORIZONTAL 1:100 VERTICAL 1:100

SECTION 4 C02

STANDARD KERB ACCESS RAMP (FOOTPATH RAMP) REFER COUNCIL DETAILS. PRIOR APPROVAL AND RAMP LOCATION TO BE CONFIRMED BY COUNCIL PRIOR TO CONSTRUCTION.

ISSUED FOR D.A. SUBMISSION ONLY NOT FOR CONSTRUCTION

IF IN DOUBT ASK

A1

20/09/2019		B	REVISED PLANS	D.K.	M.W.	<p><b>DOCUMENT CERTIFICATION</b></p> <p>Date: Rick G Wray</p> <p>BE(Civil), CP(Eng, MIE Aust., NER, RPEQ) 08293 (Director NB Consulting Engineers)</p> <p>By: Review:</p>	<p><b>NB Consulting Engineers</b></p> <p>STRUCTURAL - CIVIL - STORMWATER - REMEDIAL</p> <p>A.C.N. 076 121 616 A.B.N. 24 076 121 616</p> <p>Sydney: Ph: (02) 9984 7000 Fax: (02) 9984 7444</p> <p>Suite 207, 30 Fisher Road Dee Why N.S.W. 2099</p> <p>Gold Coast: Ph: (07) 5631 4744</p> <p>Unit 8, 1726 Gold Coast Highway Burleigh Heads QLD 4220</p> <p>E: nb@nbconsulting.com.au W: www.nbconsulting.com.au</p>	Architect:	ENVIRONA STUDIO	Project:	PROPOSED CIVIL PLANS AT 27-29 NORTH AVALON RD, AVALON	Date:	AUG 2019	Design:	D.K.	Drawn:	D.K.
19/09/2019		A	ISSUED FOR DA SUBMISSION ONLY - NOT FOR CONSTRUCTION	D.K.	M.W.			Client:	ARMADA AVALON PTY LTD	Drawing Title:	LONGITUDINAL SECTIONS - SHEET 1	Job No:	190247	Drawing No:	C04	Issue:	B

**NB Consulting Engineers**



**NOTES:**

1. ALL DIMENSIONS TO BE VERIFIED ON SITE BY BUILDER BEFORE COMMENCING WITH WORK.
2. FOR GENERAL NOTES REFER TO DRAWING NUMBER: C01.



**B85 PROFILE:**

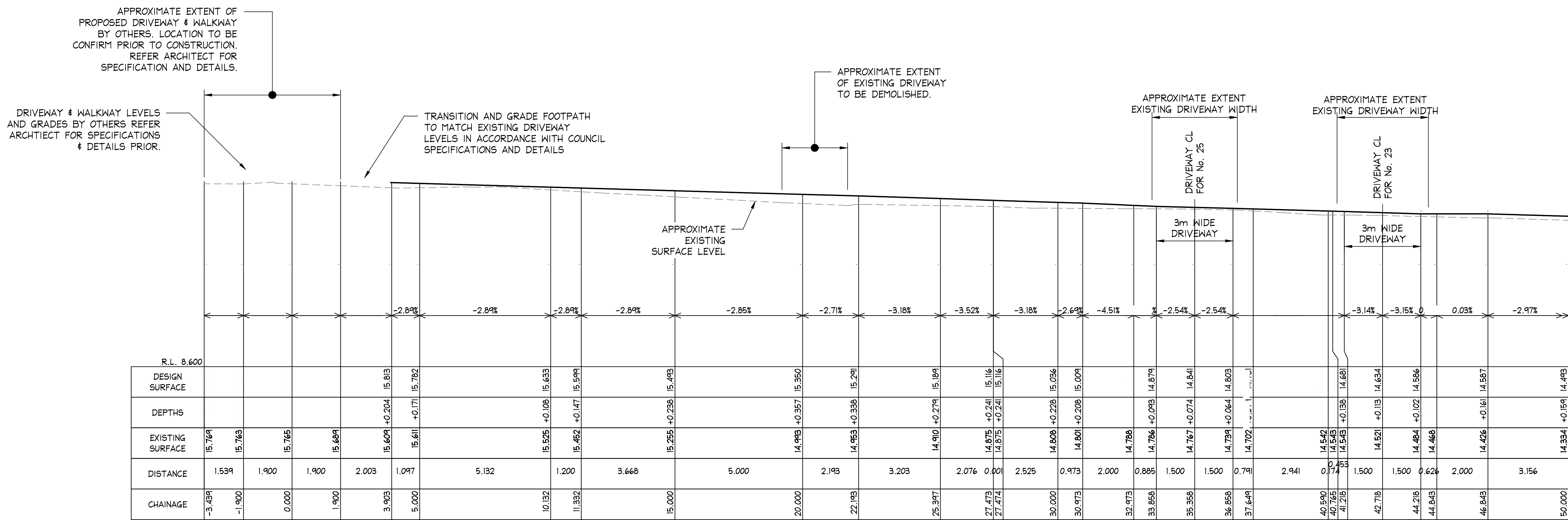
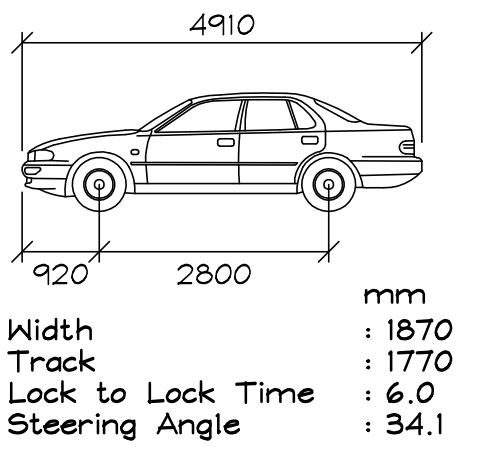

LONGITUDINAL SECTION ALONG BACK OF FOOTPATH  
FROM CH: -3.439 TO CH: 50.000  
SCALES: HORIZONTAL 1:100 VERTICAL 1:100

SECTION 5  
C01, C02

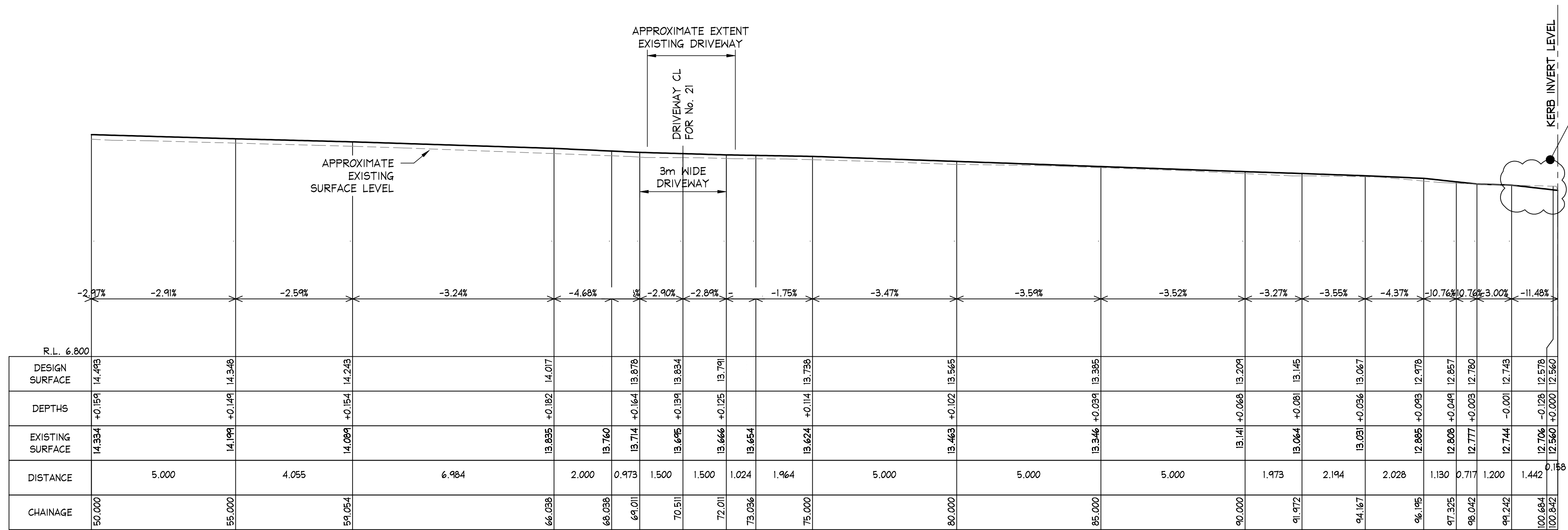

LONGITUDINAL SECTION ALONG BACK OF FOOTPATH  
FROM CH: 50.000 TO CH: 100.842  
SCALES: HORIZONTAL 1:100 VERTICAL 1:100

SECTION 5  
C01, C02

STANDARD KERB ACCESS RAMP (FOOTPATH RAMP) REFER COUNCIL DETAILS. PRIOR APPROVAL AND RAMP LOCATION TO BE CONFIRMED BY COUNCIL PRIOR TO CONSTRUCTION.

ISSUED FOR D.A. SUBMISSION ONLY NOT FOR CONSTRUCTION

IF IN DOUBT ASK

20/09/2019		B	REVISED PLANS	D.K.	M.W.	<b>DOCUMENT CERTIFICATION</b> Date: Rick G Wray BE(Civil), CP(Eng, MIEAust.), NER, RPEQ: 08293. (Director NB Consulting Engineers) The copyright of this drawing remains with Northern Beaches Consulting Engineers Pty Ltd. Trading as NB Consulting Engineers	<b>NB Consulting Engineers</b> STRUCTURAL - CIVIL - STORMWATER - REMEDIAL A.C.N. 076 121 616 A.B.N. 24 076 121 616 Sydney: Ph: (02) 9984 7000 Fax: (02) 9984 7444 Suite 207, 30 Fisher Road Dee Why N.S.W. 2099 Gold Coast: Ph: (07) 5631 4744 Unit 8, 1726 Gold Coast Highway Burleigh Heads QLD 4220 E: nb@nbconsulting.com.au W: www.nbconsulting.com.au	Architect: ENVIRONA STUDIO Client: ARMADA AVALON PTY LTD	Project: PROPOSED CIVIL PLANS AT 27-29 NORTH AVALON RD, AVALON Drawing Title: LONGITUDINAL SECTIONS - SHEET 1	Date: AUG 2019 Design: D.K. Drawn: D.K.	Job No: 190247 Drawing No: C05 Issue: B
Date:	Issue:	Description:	By:	Review:							

NB Consulting Engineers

**NOTES:**

1. ALL DIMENSIONS TO BE VERIFIED ON SITE BY BUILDER BEFORE COMMENCING WITH WORK.
2. FOR GENERAL NOTES REFER TO DRAWING NUMBER: C01.

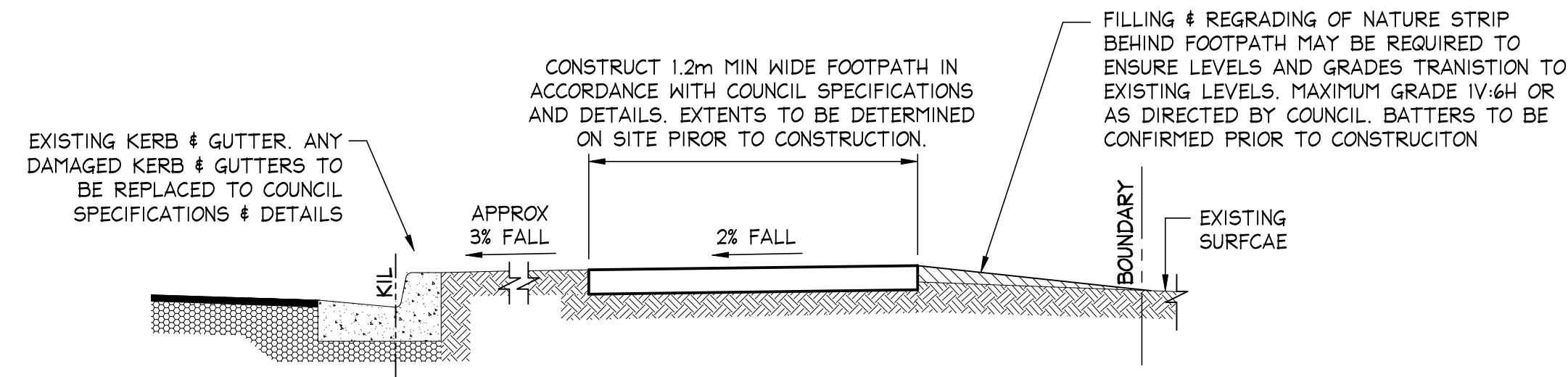
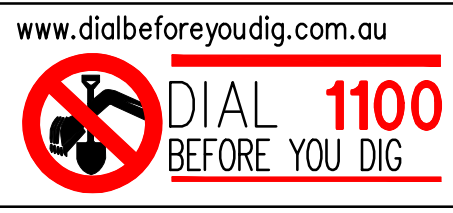

**TYPICAL FOOTPATH CROSS SECTION DETAIL**

NOT TO SCALE

ISSUED FOR D.A. SUBMISSION ONLY  
NOT FOR CONSTRUCTION

IF IN DOUBT ASK

A1

				<b>DOCUMENT CERTIFICATION</b>		<b>NB Consulting Engineers</b> STRUCTURAL - CIVIL - STORMWATER - REMEDIAL A.C.N. 076 121 616 A.B.N. 24 076 121 616		Architect: <b>ENVIRONA STUDIO</b>		Project: <b>PROPOSED CIVIL PLANS AT 27-29 NORTH AVALON RD, AVALON</b>		Date: AUG 2019	Design: D.K.	Drawn: D.K.	
20/09/2019	B	REVISED PLANS		D.K.	M.W.	Rick G Wray	Sydney: Ph: (02) 9984 7000 Fax: (02) 9984 7444 Suite 207, 30 Fisher Road Dee Why N.S.W. 2099	Client: <b>ARMADA AVALON PTY LTD</b>		Drawing Title: <b>SECTIONS &amp; DETAILS</b>		Job No: <b>190247</b>	Drawn No: <b>C06</b>	Issue: <b>B</b>	
19/09/2019	A	ISSUED FOR DA SUBMISSION ONLY - NOT FOR CONSTRUCTION		D.K.	M.W.	(Director NB Consulting Engineers)	Gold Coast: Ph: (07) 5631 4744 Unit 8, 1726 Gold Coast Highway Burleigh Heads QLD 4220 E : nb@nbconsulting.com.au W : www.nbconsulting.com.au								
Date:	Issue:	Description:	By:	Review:	The copyright of this drawing remains with Northern Beaches Consulting Engineers Pty Ltd. Trading as NB Consulting Engineers										

**NB Consulting Engineers**