



Senica
consultancy group

Energy Efficiency | Waste | Environmental

SITE WASTE MANAGEMENT REPORT

4 Delmar Parade and 812 Pittwater Road, Dee Why

SP 32071 and SP 32072



Prepared for:

Dee Why 3 Pty Ltd & Dee Why 4 Pty Ltd

Report SW21/09721

DOCUMENT CONTROL

Document and Project Details					
Document Title:	Site Waste Minimisation and Management Report				
Author:	Duncan Hope Environmental Services Manager				
Project Manager:	Duncan Hope				
Date of Issue:	22/11/2022				
Job Reference:	SW21/09721				
Synopsis:	This document presents a Site waste minimisation and management report for a proposed mixed-use development at 4 Delmar Parade and 812 Pittwater Road, Dee Why NSW				
Client Details					
Client:	Dee Why 3 Pty Ltd & Dee Why 4 Pty Ltd				
Primary Contact:	--				
Document Distribution					
Version	Date	Status	Distribution – Number of copies		
			Client	Council	Other
A	23/09/2021	Draft	1		
B	02/10/2021	Amend			
C	10/11/2021	Amend			
D	29/11/2021	Final			
E	07/12/2021	Final			
F	22/11/2022	Final			
G	09/12/2022	Final			
H	13/12/2022	Final			
Document Verification					
Checked by:			Issued by:		
DH			DH		

DISCLAIMER

This report was prepared for the purposes and exclusive use of the stated client to accompany an application to the relevant Council for the specified development application and is not to be used for any other purpose or by any other person or corporation.

The information contained in this report is based on independent research undertaken by Senica Consultancy Group. To the best of our knowledge, it does not contain any false, misleading or incomplete information.

Senica Consultancy Group accepts no responsibility for any loss or damage suffered howsoever arising to any person or corporation who may rely on or use this report in contravention of the terms of this clause.

TABLE OF CONTENTS

1	Introduction	2
1.1	<i>Summary</i>	2
2	Building characteristics	3
2.1	<i>Site description</i>	3
2.2	<i>Site Analysis</i>	3
3	Description of proposal	4
3.1	<i>Proposed Development</i>	4
3.2	<i>Site Access</i>	4
3.3	<i>Site Services</i>	4
4	Purpose of the report	5
4.1	<i>aims</i>	5
4.2	<i>objectives</i>	5
4.3	<i>legislative drivers</i>	5
5	Demolition	6
5.1	<i>general outline</i>	6
5.2	<i>waste Avoidance, Minimisation and Control Strategies</i>	6
6	Construction phase	8
6.1	<i>General Outline</i>	8
6.2	<i>Waste Avoidance, Minimisation & Control Strategies</i>	8
7	Post construction (operational) phase	10
7.1	<i>Waste and recycling generation rates</i>	10
7.2	<i>Storage</i>	12
7.3	<i>Servicing (collection)</i>	15
7.4	<i>Garbage transport</i>	16
7.5	<i>Bulky waste</i>	18
7.6	<i>Green waste</i>	18

1 INTRODUCTION

This Site Waste Minimisation and Management Plan (SWMMP) Report has been prepared on behalf of the Dee Why 3 Pty Ltd & Dee Why 4 Pty Ltd and should be read in conjunction with the plans encompassing Project No. : 221054 prepared by Rothe Lowman.

The report summarises the waste minimisation and management practices intended to be implemented as part of the construction of a mixed use commercial/multi-storey unit residential development and its operational use.

1.1 SUMMARY

The proponent proposes:

- i. Demolition of existing buildings, tree removal and site clearing
- ii. Construction of 2x new mixed-use buildings over a shared two storey basement car park comprising:
 1. 219 residential apartments
 2. Commercial tenancies on ground floor

The development proposes associated garbage rooms at basement 1 level with collection from a loading dock at ground level, related earthworks and landscaping"

This report is an outline of the waste minimisation and management policies and procedures to be implemented by contractors during the demolition phase, construction phase and the property manager/owners corporation during the post construction (operational phase) of the development.

These policies and procedures will set a framework for all parties to minimise generation of residual (non-recyclable) waste, and to take advantage of the opportunities for re-use of waste materials by ensuring that efficient recovery and segregation measures for all waste materials are provided.

2 BUILDING CHARACTERISTICS

2.1 SITE DESCRIPTION

The site is identified legally as the following:

- SP 32071; and
- SP 32072.

It is commonly known as 4 Delmar Parade and 812 Pittwater Road, Dee Why. The subject site has an area of 7,761.00 m².

Please refer to the below aerial image.



Figure 1 - Aerial Image

2.2 SITE ANALYSIS

The site is located within the a well established area with a mixture of commercial and residential developments. There are existing commercial developments on the site with associated light infrastructure. The existing commercial developments have minimal existing waste infrastructure on site with no apparent waste holding room.

3 DESCRIPTION OF PROPOSAL

3.1 PROPOSED DEVELOPMENT

The proposed development includes the demolition of an existing commercial development with light infrastructure and the subsequent construction of a multi-storey mixed residential/commercial building and ancillary site works.

The proposed building will include the following:

- Parking for 337 cars over 2 basement levels;
- Two buildings with a total of six building cores with appurtenant waste chutes;
- Lift motor, plant, service and garbage rooms;
- Ground floor commercial tenancies;
- Upper ground floor level and upper levels consisting of a total of 219 units

3.2 SITE ACCESS

The subject site has frontages to Delmar Parade and Pittwater Road. Vehicular access to the site is via a shared driveway on the eastern edge of the site, adjacent to Delmar Parade .

3.3 SITE SERVICES

The site has access to all necessary essential services including water, sewer, electricity and telecommunications.

4 PURPOSE OF THE REPORT

4.1 AIMS

The aim of the SWMMP is to outline measures to minimise and manage waste and resource recovery during the demolition phase, construction phase and the post construction (operational) phase.

The SWMMP will describe;

- Volume and type of waste and recyclables to be generated
- Storage and treatment of waste and recyclables on the development site
- Disposal of residual wastes and reprocessing options for recyclables
- Procedures for post construction (operational) management after handover of the development

4.2 OBJECTIVES

The objective of the SWMMP is to provide a planning system to effectively manage waste and resource recovery associated with this development, including;

- Promote improved project management
- Minimise waste generation
- Maximise reuse and resource recovery
- Minimise the environmental impacts associated with residual waste generated by this development
- Ensure the appropriate storage and collection of residual waste

To ensure ongoing waste management systems are compatible with collection services offered by commercial waste transporters and the Northern Beaches Council.

4.3 LEGISLATIVE DRIVERS

Table 1 - Environmental Legislation specific to waste management

Legislation/Guidelines	Description
Protection of the Environment Operations Act 1997	This Act is the primary NSW environment protection legislation covering air, noise, water, land and waste management
Waste Avoidance and Resource Recovery Act 2001	Sets NSW framework for waste hierarchy and allows the preparation of waste strategies addressing specific waste streams and setting landfill diversion and resource recovery targets
Waste Avoidance and Resource Recovery Strategy 2007	Proposes priority areas for waste management and resource recovery. Details current targets
Northern Beaches Development Control Plan 2013, Part 3N: Waste Minimisation and Management	Aims to facilitate sustainable waste management within the Northern Beaches Shire LGA in a manner consistent with ESD principles.
Model Waste Not DCP Chapter 2008 (DECC)	Provides a framework chapter for NSW LGA's to address Waste Not DCP
Better Practice Guide for Waste Management in Multi Unit Dwellings 2002 (Resource NSW)	Provides guideline for addressing waste management in medium or high density residential developments

5 DEMOLITION

5.1 GENERAL OUTLINE

The management of the site will be the responsibility of the project manager, who will administer waste handling systems, as specified by the Northern Beaches Council, WorkSafe and as detailed in this report.

The demolition phase of this development is to comply with the aims and objectives outlined in Section 3 of this report.

The demolition phase involves the demolition of an existing commercial building, associated light infrastructure, site clearing, and excavation.

5.2 WASTE AVOIDANCE, MINIMISATION AND CONTROL STRATEGIES

In relation to site clearance and excavation activities, specialised waste disposal & treatment contractors will be selected who are appropriately licenced, and have demonstrated experience in maximising resource recovery. The following control strategies will be implemented during the demolition phase;

- All demolition will be conducted in accordance with requirements of the WorkSafe Authority and Australian Standard 2601-1991 *The demolition of structures*
- Any asbestos, hazardous and/or intractable wastes are to be disposed of in accordance with the WorkSafe Authority and Environmental Protection Authority
- Re-use excavated materials on-site and disposal of excess to an approved site
- All salvaged material will be removed manually; hydraulic excavators will remove the remainder
- Allocation of an assigned area within the development site to be identified for stockpiling of segregated recyclable materials (for materials to be re-used on-site) and for staging areas for transport to off-site re-processing facilities
- All skip and bulk bins will be located within the assigned area, clearly identified for each material, and not impeding on the footpath or road reserve
- Project manager to retain all weighbridge or re-processing facility dockets to ensure responsible disposal and recycling options are being employed by contractors
- All waste generated is to be documented and handled in accordance with Table 2 *Demolition Volumes and Reuse/Recycling Potential*
- At the excavation stage, the frontage to Delmar Parade will be utilised as the site access. The excavated material, not used on site, will be loaded onto trucks and transported to an approved landfill site or another suitable location.

Table 2 - Demolition Volumes and Reuse/Recycling Potential

Materials	Document Volume (m ³)	On-Site	Off-Site	Disposal
Hardwood	13	Separated	Sold for re-use	Second hand supplier
Other Timber	5	Separated	Chipping for mulch/fuel	Green waste re-processing facility
Doors, Windows	5	Separated	Sold for re-use	Second hand supplier
Steel	10	Nil	To metal recyclers	Metal recycling
Downpipes, Gutters	4	Nil	To metal recyclers	Metal recycling
Ceramic Tiles	8	Cleaned and separated	Sold for re-use	Recycling facility/second hand supplier
Green Waste	9	Composted or mulched	Nil	Green waste re-processing facility
Concrete	25	Re-used as sub-base / fill	Concrete crushing	Quarry or landfill licenced to crush concrete
Bricks	14	Broken brick for fill. Whole bricks to be cleaned and salvaged	Recycling company	Quarry or landfill licenced to crush bricks/masonry. Or Second hand supplier
Plasterboard	12	Separated	Recycling company	Licenced re-processing facility. Or return to supplier
General Waste	3	Nil	Nil	Licenced waste facility
Other Wastes	2	Separated	Nil	Licenced waste Facility

6 CONSTRUCTION PHASE

6.1 GENERAL OUTLINE

The management of the site will be the responsibility of the project manager, who will administer waste handling systems, as specified by Northern Beaches Council, WorkSafe and as detailed in this report.

The construction phase of this development is to comply with the aims and objectives outlined in Section 3 of this report.

The construction phase will involve car parking over two basement levels, lift motor, plant, service and garbage room, three retail tenancies and seven upper levels consisting of a total of 219 units.

6.2 WASTE AVOIDANCE, MINIMISATION & CONTROL STRATEGIES

To reduce the amount of waste on site during construction of the development the following control strategies will be required of all contractors and/or personnel:

- Order materials to size
- Avoid over-ordering
- Order pre-cut or pre-fabricated materials
- Reduce packaging at source or products with minimal packaging
- Where possible materials to be re-used on site or shipped to recycler
- All salvaged material will be removed manually; hydraulic excavators will remove the remainder;
- Allocation of an assigned area within the development site to be identified for stockpiling of segregated recyclable materials (for materials to be re-used on-site) and for staging areas for transport to off-site re-processing facilities;
- All skip and bulk bins will be located within the assigned area, clearly identified for each material, and not impeding on the footpath or road reserve;
- Project manager to retain all weighbridge or re-processing facility dockets to ensure responsible disposal and recycling options are being employed by contractors;
- All waste generated is to be documented and handled in accordance with Table 3 Construction Volumes and Reuse/Recycling Potential

Table 3 - Construction Volumes and Reuse/Recycling Potential

Materials	Document Volume (m ³)	On-Site	Off-Site	Disposal
Hardwood	4	Separated	Sold for re-use	Second hand supplier
Other Timber	4	Separated	Chipping for mulch/fuel	Green waste re-processing facility
Doors, Windows	0	Separated	Sold for re-use	Second hand supplier
Steel	3	Nil	To metal recyclers	Metal recycling
Downpipes, Gutters	1	Nil	To metal recyclers	Metal recycling
Ceramic Tiles	1	Cleaned and separated	Sold for re-use	Recycling facility/second hand supplier
Green Waste	3	Composted or mulched	Nil	Green waste re-processing facility
Concrete	2	Re-used as sub-base / fill	Concrete crushing	Quarry or landfill licenced to crush concrete
Bricks	2	Broken brick for fill. Whole bricks to be cleaned and salvaged	Recycling company	Quarry or landfill licenced to crush bricks/masonry. Or Second hand supplier
Plasterboard	2	Separated	Recycling company	Licenced re-processing facility. Or return to supplier
General Waste	5	Nil	Nil	Licenced waste facility
Other Wastes	2	Separated	Nil	Licenced waste Facility

Note: During construction, all waste materials will be separated and temporarily stored on-site. It is proposed all such materials will either be recycled or disposed of as per Table 2 Demolition Volumes and Reuse/Recycling Potential.

7 POST CONSTRUCTION (OPERATIONAL) PHASE

The following assessment of waste volumes is an estimate only and will be influenced by building management, cleaning arrangements, individual tenant’s attitude and obligation regarding waste disposal and recycling.

7.1 WASTE AND RECYCLING GENERATION RATES

Discussion with Council’s Waste Education Officer, Cathryn Hannemann on 03/07/2021, has provided the following waste generation rates:

Waste Type	Waste Generation Rate (Litres per Unit per Week)
General Waste	80
Recycling (Paper and Cardboard)	60
Recycling (Glass and plastic containers)	40

Recycling is to be collected in two separate bins as identified above.

Council’s Waste Education Officer also advised that 5 x 240L MGB’s are to provided for the development to accommodate green waste generated by the residents and tenants. The proposed development is to be serviced, for general waste and recycling, twice weekly by Council or contractor.

Based on the information provided by Council the waste generated and the required number of MGB’s have been identified in Table 4.

Table 4 - Residential Generation Rates

Total	Waste Gen. rate (L/Unit/Week)	Number of Units	Waste (L/Week)	Collections per week	MGB Size (L)	Number of MGB required	
	Garbage	80	219	17520	2	660	14
	Recycling (Paper/Cardboard)	60	219	13140	2	240	28
	Recycling (Containers)	40	219	8760	2	240	19

Table 5 - Building Core Waste Generation Rates

Building Core A	Waste Gen. rate (L/Unit/Week)		Number of Units	Waste (L/Week)	Collections per week	MGB Size (L)	Number of MGB required
	Garbage	80					
	Recycling (Paper/Cardboard)	60					
	Recycling (Containers)	40					
	28	2240	2	660	2		
	28	1680	2	240	4		
	28	1120	2	240	3		
Building Core B	Waste Gen. rate (L/Unit/Week)		Number of Units	Waste (L/Week)	Collections per week	MGB Size (L)	Number of MGB required
	Garbage	80					
	Recycling (Paper/Cardboard)	60					
	Recycling (Containers)	40					
	28	2240	2	660	2		
	28	1680	2	240	4		
	28	1120	2	240	3		
Building Core C	Waste Gen. rate (L/Unit/Week)		Number of Units	Waste (L/Week)	Collections per week	MGB Size (L)	Number of MGB required
	Garbage	80					
	Recycling (Paper/Cardboard)	60					
	Recycling (Containers)	40					
	24	1920	2	660	2		
	24	1440	2	240	3		
	24	960	2	240	2		
Building Core D	Waste Gen. rate (L/Unit/Week)		Number of Units	Waste (L/Week)	Collections per week	MGB Size (L)	Number of MGB required
	Garbage	80					
	Recycling (Paper/Cardboard)	60					
	Recycling (Containers)	40					
	42	3360	2	660	3		
	42	2520	2	240	6		
	42	1680	2	240	4		
Building Core E	Waste Gen. rate (L/Unit/Week)		Number of Units	Waste (L/Week)	Collections per week	MGB Size (L)	Number of MGB
	Garbage	80					
	Recycling (Paper/Cardboard)	60					
	Recycling (Containers)	40					
	62	4960	2	660	4		
	62	3720	2	240	8		
	62	2480	2	240	6		
Building Core F	Waste Gen. rate (L/Unit/Week)		Number of Units	Waste (L/Week)	Collections per week	MGB Size (L)	Number of MGB required
	Garbage	80					
	Recycling (Paper/Cardboard)	60					
	Recycling (Containers)	40					
	35	2800	2	660	3		
	35	2100	2	240	5		
	35	1400	2	240	3		

Table 6 - Commercial Generation Rates – Retail

Commercial (4 Delmar Parade)	Waste							
	Gen. rate (L/100m ² /Day)	Days per week	NLA (m ²)	Waste (L/Week)	Collections per week	MGB Size (L)	Number of MGB	
Garbage	50	6	325.4	977	2	240	3	
Recycling	50	6	325.4	1424	2	240	3	

Commercial (812 Pittwater Road)	Waste							
	Gen. rate (L/100m ² /Day)	Days per week	NLA (m ²)	Waste (L/Week)	Collections per week	MGB Size (L)	Number of MGB	
Garbage	50	6	438.5	1316	2	240	3	
Recycling	50	6	438.5	1919	2	240	4	

7.2 STORAGE

The storage of residential waste will be within individual chute rooms at the B1 level adjacent to each lift core. Each core waste storage room will contain enough bins to accommodate MGB's required for the generation in the tables above, plus one additional bin to be used on collection day during waste collection to ensure chutes remain operational.

Waste bins will be collected from each core by the property manager/owners corporation with a trolley tractor and taken to the collection area within the loading dock via the service hoist on collection days.

Storage of residential recycling bins occurs within dedicated recycling bin rooms within each residential lobby on each floor of the building, with spatial provision for spare 240L MGBs to be stored within the waste room at the base of each chute.

Recycling bins will be collected from each level on collection day. Paper and Plastic recycling will occur on different days.

The loading dock has been sized to accommodate storage of all residential general waste bins and recycling bins on collection day.

Waste rooms dedicated to storage of commercial waste bins are provided in B1 beneath the Pittwater Rd retail offering as well as beneath the Delmar Pde retail offering. It is expected that commercial waste will be collected by a private contractor.

For ease of collection, a service bay has been provided in B1 adjacent to the Pittwater Rd retail offering. The service bay can accommodate a small rigid vehicle, providing an option for private collection to occur in the basement.

If a larger collection vehicle is required, the property's caretaker will transport bins to the collection bay on Ground Floor on collection day, and return them to their respective waste rooms following collection.

There is no central residential bin room, reducing handling, and simplifying cleaning requirements per core.

These rooms shall be constructed in accordance with the provisions of the Northern Beaches Council Development Control Plan, and at a minimum be of approved solid impervious material and shall be cement rendered internally to a smooth even surface coved at all intersections.

The ceiling of the waste room will be finished with a rigid smooth faced non-absorbent material capable of being cleaned. The walls, floor and ceilings of the garbage room shall be finished with a light colour.

A tap and drainage with connection to the sewer are to be provided within the garbage storage area. Hose cocks shall be protected or located so that they cannot be damaged. A hose of adequate length and fitted with a nozzle is to be connected to the hose cock to allow for adequate cleaning of the waste room and receptacles.

The room will be adequately ventilated, well lit, and appropriately signposted to distinguish paper/cardboards recycling bins from container recycling bins and residual waste (garbage) bins.

The size of the waste room will be sufficient to house the recommended number of mobile garbage bins for the development, as well as incorporating adequate clearance between each mobile garbage bin. The minimum sizes for the proposed bins are identified in Appendix B.

A close fitting and self-closing door openable from within the room must be fitted to the waste room. The waste room will be constructed so as to prevent the entry of vermin.

The waste room must be ventilated in accordance with the provisions of the Building Code of Australia (as in force at the time of construction) by either:

- Permanent unobstructed natural ventilation openings direct to the external air, not less than 5% of the floor area,
- Mechanical exhaust ventilation system exhausting at a rate of 5L/s.m² floor area, with a minimum rate of 100L/s min

The waste room will be provided with artificial light controlled by switches located both outside and inside the room.

Where storage and drainage racks are provided, they will be constructed of galvanised metal or other approved materials which are durable, impervious and no-corrosive.

Racks should be installed at least 50mm clear of walls with the lowest racks installed at least 300mm above the floor. Racks should be designed to prevent receptacles/containers placed thereon from coming in to contact with the walls.

Clear and easy to read “NO STANDING” and “DANGER” signs must be fixed to the external face of each waste and recycling room as appropriate. Clear and easy to read signs designating the storage of recyclables and general waste must be fixed to the internal walls as appropriate.

The location of the garbage rooms have been designed to be easily accessible with door clearances that are consistent with AS1428.1-2009.

The garbage rooms will not affect the amenity of any adjacent properties and has been designed as an integrated part of the overall design.

7.3 SERVICING (COLLECTION)

As per the provisions of the Development Control Plan, it is intended that the waste be collected twice weekly from a designated location on site. Council have advised that the waste will be collected in between the hours of 0600 and 1800 on collection days.

Commercial waste will be collected by a private contractor and will not be collected or mixed with the residential waste.

The property's caretaker will ensure that all Residential bins are prepared and presented within an allocated service area, the night prior to the collection day.

The Property's caretaker will ensure that all Commercial bins are prepared and presented within the allocated service area, the night prior to the collection day.

The design of the development allows for the garbage and recyclables to be transported to the waste collection bay located on the ground floor, to allow for Northern Beaches Council and/or their contractor for pick-up.

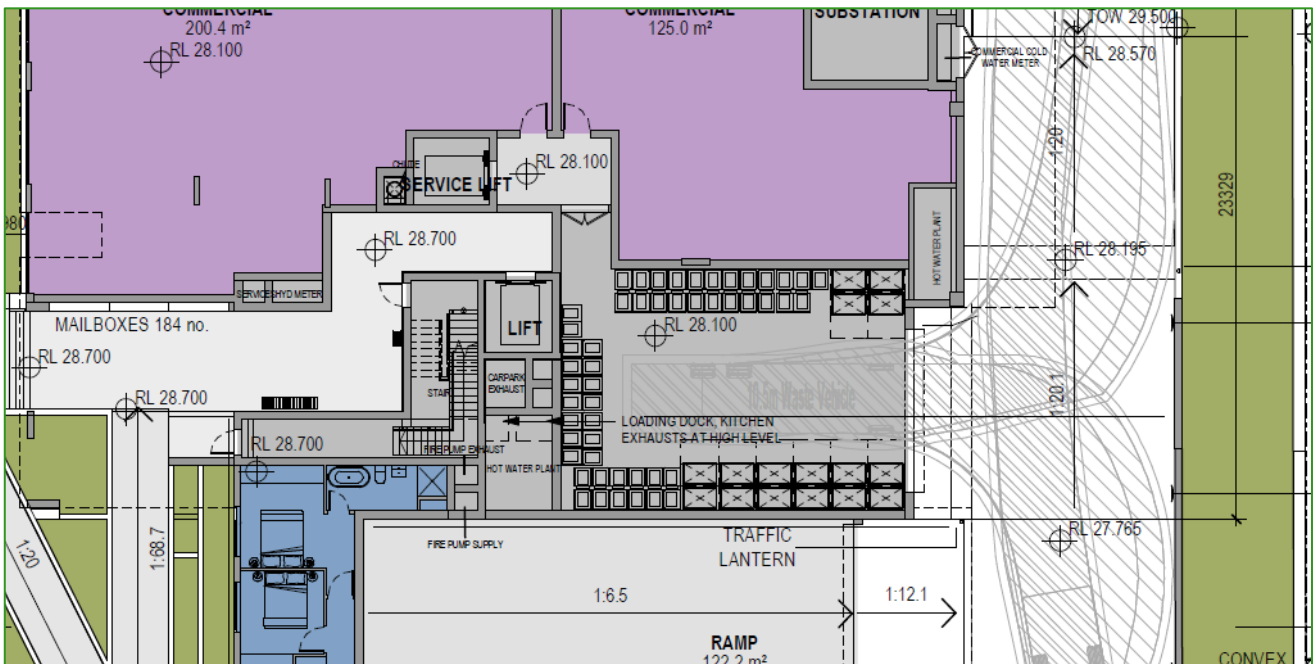

Figure 2 - Temporary Bin Collection Point

The waste holding area will have adequate space to hold the greater of;

- Total volume of bulky waste; or
- Total quantity of garbage and recycling MGB's

The development has been designed so as to allow a 10.5m Heavy Rigid Vehicle (rear loader) to collect the garbage from the loading space without impacting on local traffic flow.

The site can be accessed from Delmar Parade. Adequate turning circles, including a swept path analysis, will be provided by the traffic consultant's report.

Discussions, with Council Officers have identified the need for a Loading Dock Management Plan (to be prepared at Construction Certificate stage). The LDMP will be managed by a Loading Dock Manager.

The Loading Dock Manager will be in charge of scheduling the use of the loading/collection bay thus minimising the potential for the development to negatively impact the local traffic flow.

The proposed design allows for service vehicles to enter the site in a forward direction, park in the allocated loading dock area while servicing the bins, then exit the site in a forward direction.

The waste collection point area is to be generally level. The sections of driveway / access way that will be used by collection vehicles will be designed, as per Council's requirements, for a Heavy Rigid vehicle in accordance with the provisions of Australian Standard 2890.2-2002 *Parking facilities Part 2: Off-Street commercial vehicle facilities*.

Bins will be returned to the garbage rooms as soon as practicable following servicing.

7.4 GARBAGE TRANSPORT

A Garbage chute at each core will be employed by the development, as there are residential units greater than three storeys above the garbage storage room. There is proposed to be a waste chute located adjacent to the lift, with access provided on each level for residents use.



Figure 3 - Waste Chute and Recycling cupboard example

This waste chute is for general waste and will terminate in the basement level waste holding room. Adjacent to the waste chute on each level, a recycling cupboard will be provided.

This cupboard will have sufficient space to accommodate two 240L MGB recycling bins, with one being for paper/cardboard and the other bin being for glass/plastic containers.

The paper/cardboard recycling bin will have a blue lid, whereas the glass/plastic container bin will be provided with a yellow lid. The bins will be clearly labelled to identify the respective materials that are acceptable in the relevant bin.

The relevant MGB's within the recycling cupboards on each level are to be checked and maintained as required on a daily basis.

The waste caretaker or building management will then replace the full Recycling MGB with an empty MGB and transport the full MGB to the waste holding room for storage until collection.

The waste chutes will terminate in a waste holding room on Basement 1. The waste room will have capacity for storage based on bi-weekly collection.

All residential waste generated by residents will be transported to a chute outlet on each level as identified above. Residents will sort their refuse in to general waste and recycling materials and dispose of them accordingly.

General waste should be wrapped, bagged or otherwise secured before it is disposed of in the chute system. Bagged waste should not exceed the requirements of the chute and diverter system.

Recyclable materials must not be bagged and must be separated in to cardboard and other recyclable materials. Larger cardboard boxes and other cardboard objects should not be placed in the chute, but transported to the waste room and collected there within the bulky goods storage area.

The garbage chute is to have a diameter greater than 500mm, insulated to minimise noise, and be constructed in accordance with the Building Code of Australia (BCA).

Each chute will have a self closing hopper (opening) for residents to dispose of residential waste.

The garbage chute will terminate at the garbage storage room and the chute will have a shut off mechanism to allow the property manager/owners corporation to transfer full bins out and empty bins in.

A 660L MGB will be located below the waste chute utilising a 3 x 660L bin linear carousel. The carousel will replace a filled MGB with an empty MGB as required. Once filled the waste caretaker will transport the 660L MGB from the linear carousel to the holding area and replace it in the carousel with an empty 660L MGB.

Each individual residential dwelling shall be no more than 75 metres from the nearest waste room. This distance should be shortened to 50 metres for aged or disabled residents.

All equipment movements in the garbage room and from the garbage room to the loading space are to be managed by the building manager or custodial staff.

Additional MGB's have been provided to allow for the logistics of moving the MGB's while ensuring there is a receptacle under the waste chutes.

The waste caretaker is to ensure that the chutes and recycling cupboard on each level are checked a minimum of once per day.

The waste caretaker shall be responsible for ensuring the waste rooms and related equipment are kept in a clean and working order.

The waste caretaker shall also ensure that the waste and recycling bins are provided in the waste collection point area on the relevant servicing days by the required times. Once serviced the bins are to be moved back to the main Waste room.

A trailer able to be connected to a motorised trolley or a bin tug, can be utilised to transport the MGB's from waste holding rooms to the primary bin holding room adjacent to the collection bay.

A dedicated parking bay has been provided for a motorised trolley and trailer within Basement 1.

Occupational health and safety of bin transfers must be considered for larger bins (e.g. ability to safely move a bin that may weigh more than the person trying to move it).

7.5 BULKY WASTE

The development will employ a dedicated room at basement 1 level for residents to temporarily store unwanted bulky items until suitable disposal/transport options can be arranged.

Council's Waste Management Guidelines required a minimum of 4m³ per 10 dwellings. Given that the development has 219 dwellings there is proposed to be 87.6 m³ for the storage of bulky waste.

Bulky waste is to be collected once every five weeks.

The property's caretaker will transport bulky waste from the dedicated room to the loading/collection bay on GF via the service lift.

7.6 GREEN WASTE

Council's Waste Education Officer has advised that Council would require five 240L MGB's to be provided for the development to accommodate green waste generated by the development.

It is proposed that five green lidded 240L MGB's be provided in the dedicated green waste room at basement 1 level, each clearly identified as green waste.



Appendix A

Signage for Garbage Rooms





Appendix B

Waste Management Equipment

Dimensions - Weights - Standards

■ Nominal volume:	240 litres
■ Net weight:	approx 13 kg
■ Max load:	96 kg
■ Permitted total weight:	110 kg

■ A	1060 mm	■ D	730 mm	■ G	550 mm
■ B	990mm	■ E	585 mm		
■ C	660 mm	■ F	400 mm		

Measurements to be used as a guide only – variations will occur

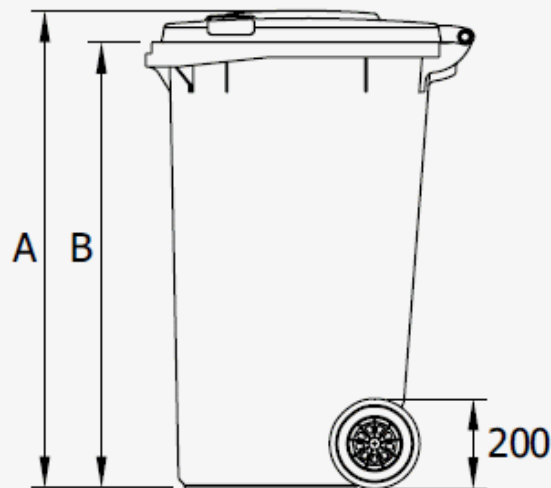
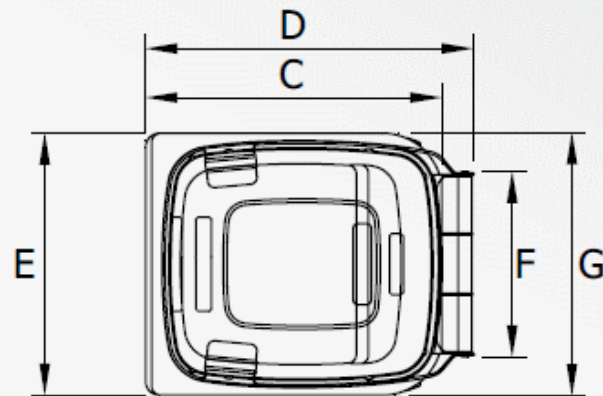

Dimensions - Weights - Standards

■ Nominal volume:	660 litres
■ Net weight:	43 kg
■ Max. load:	265 kg
■ Permitted total weight:	310 kg

Measurements to be used as a guide only - variations will occur

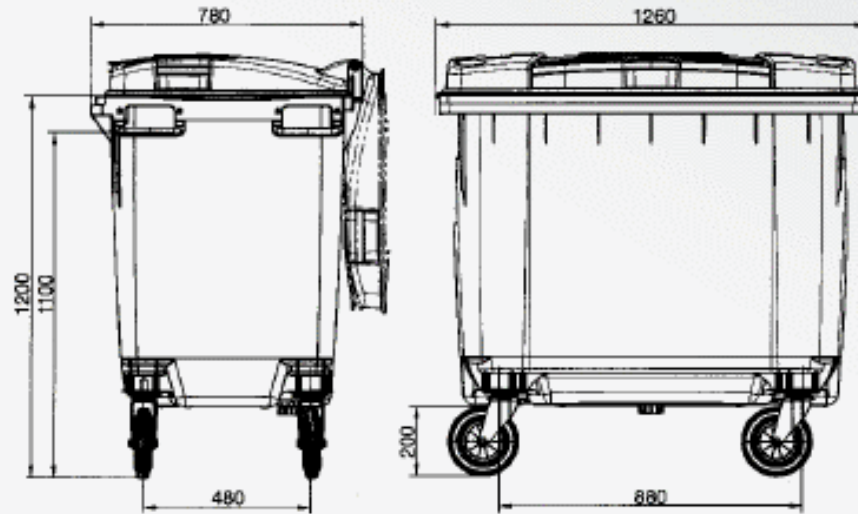



Chute Solutions.TM
an Elephants Foot Company



LINEAR SYSTEM

Elephants Foot's Linear System is a versatile waste handling solution for many types of multi-storey or multi-level developments. The Linear Track System collects waste or recycling being disposed from the floors above through the chute system, discharging the material via a hopper that feeds the bins.

Electromechanically driven with automated operation, the system utilises linear motion to automatically replace bins once filled. Once all bins are full, an indicator light will illuminate, signifying that the bins are ready for withdrawal and collection.

- ✓ Simple operation with user friendly controls
- ✓ Increased waste servicing efficiency for the development
- ✓ Automatic system control with manual override
- ✓ Low maintenance costs
- ✓ Quiet and efficient operation
- ✓ Maximise safety for residents, caretakers and collectors
- ✓ Can suit low ceiling clearances
- ✓ Retro fitting options to suit other chutes systems
- ✓ Compliant with relevant Building Codes and Standards
- ✓ Standard 12 month warranty

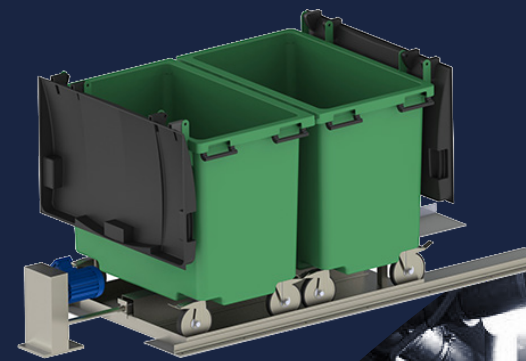

Available with or without compaction unit, our Linear come suited for 240L, 660L and 1100L mobile garbage bins.

See reverse side for more information.





240 LITRE LINEAR TRACK SYSTEM

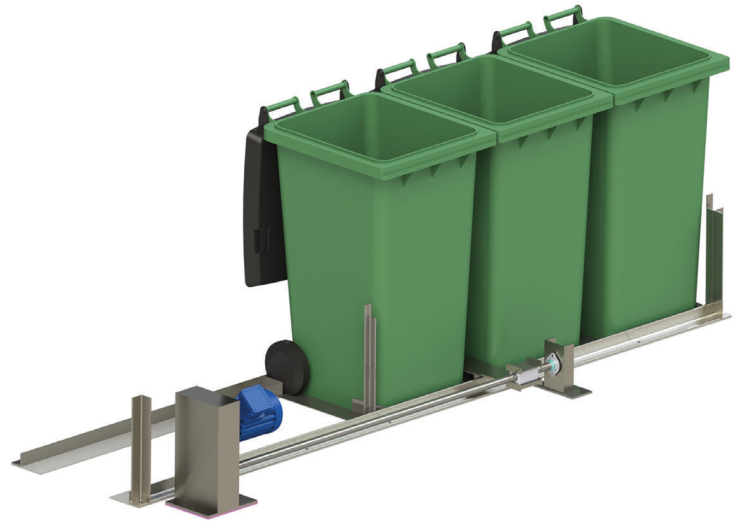

No. of Bins	Reference (mm)		
	A	B	C
2	2500	400	2000
3	3700	600	3000
4	4800	1100	4250

Available with or without compaction unit, our standard 240 litre bin Linear Track System can support 2, 3 or 4 bin quantities.

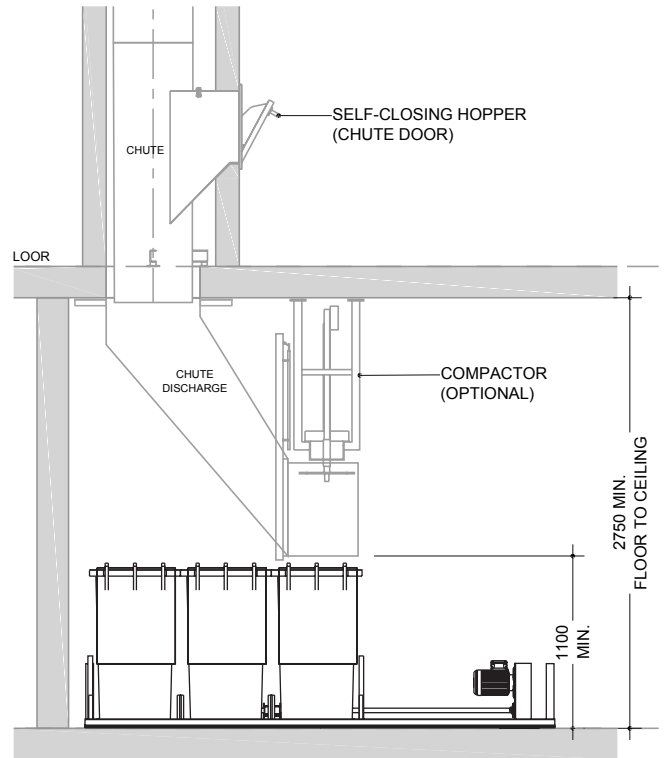
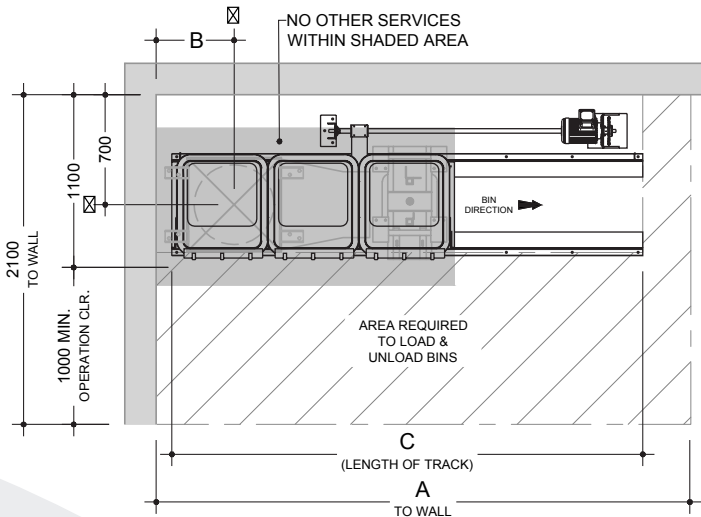

Notes:

Bins not provided by Elephants Foot

Drawings shown are for general information purposes only and provide minimum equipment spacial requirements for waste room design.

These drawings are not intended for site specific use or for construction. Each project is unique and will be designed to suit.

Additional equipment options, systems and configurations are available. For design assessment, information and advice, please contact an Elephants Foot design consultant on 1300 435 374

APPENDIX C WASTE MANAGEMENT EQUIPMENT SPECIFICATIONS

APPENDIX C.1 TYPICAL BIN MOVER – BATTERY ELECTRIC

PEDESTRIAN TUG – BIN MOVER



Alitrak AU TT600 –
with 2 x 240L Bins



Alitrak AU TT900 –
with 2 x 660L Bins



Alitrak AU TT600 –
With 4 x 240L Bins

RIDE OR SEAT ON TUG – BIN MOVER



DEC Bull+Canopy and
Aluminium Trailer

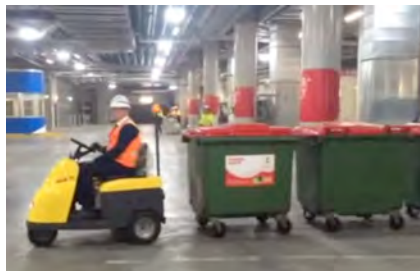

DEC Bull with Bin Towing
Devices



Skatework with Trailer



Cushman Burden Carrier
with Trailer

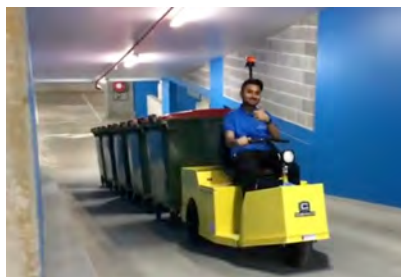

Cushman 5/8K + Bin Towing



Motrec MP-240 with trailer

Typical Applications:

- Move trolleys, waste bin trailers and 240L, 660 L/ 1100 Litre bins up and down a ramp incline. Ideal for Apartment Buildings (to move waste bins located at a basement level to road level).
- Quiet, smooth operation with zero emissions and simple to use, no driver's licence required.

Features:

- Up to 1 Tonne on a ramp surface (depending on ballast and incline)
- Anti-rollback system on slopes
- Small Foot print: 130 cm Long x 789 cm Wide x 90 cm High (with handle in folded position)
- Pin Hitch is standard however alternate hitching options may be available to suit your applications (e.g. Tow ball)

Safety Features:

- Intuitive paddle lever control
- Safety button stops and repels the unit if activated when reversing
- Site assessment recommended to check ramp incline steepness (see useful contacts)

NOTE:

Dangers of using pedestrian tugs on ramps:

- Wet ramps, slow operation.
- Mixing pedestrian and vehicles on ramps – inattentive drivers.

Advantages of using compact "ride-on" Tugs on ramps

- Safety and faster movement of bins

USEFUL CONTACTS

Spacepac does not warrant or make representation for goods or services provided by suppliers.

City of Sydney Council Customer Service

Phone: 02 9265 9333

Or

Local Council Customer Service

Phone:

SULO MGB (MGB, Public Place Bins)

Phone: 1300 364 388

Or

OTTO MGB (MGB, Public Place Bins)

Phone: DARREN 0420 720 298

SPACEPAC INDUSTRIES (Tugs, Tractors, Bin Hitches and Bin Movers)

Phone: 1300 763 444 or Email: sales@spacepac.com.au
Call Mike at (0412 369 552)

CLOSED LOOP (Organic Dehydrator)

Phone: 02 9339 9801

RUD (PUBLIC PLACE BINS, RECYCLING BINS)

Phone: 07 3712 800

CAPITAL CITY WASTE SERVICES

Phone: 02 9359 999

REMONDIS (Private Waste Service Provider)

Phone: 13 73 73

SITA ENVIRONMENTAL (Private Waste Service Provider)

Phone: 13 13 35

NATIONAL ASSOCIATION OF CHARITABLE RECYCLING ORGANISATIONS INC. (NACRO)

Phone: 03 9429 9884 Email: information@nacro.org.au

PURIFYING SOLUTIONS (Odour Control)

Phone: 1300 636 877 Email: sales@purifyingsolutions.com.au

ELEPHANTS FOOT RECYCLING SOLUTIONS (Chutes, Compactors and eDiverter Systems)

44-46 Gibson Avenue, Padstow NSW 221
Phone: 1800 025 073

APPENDIX B.4 TYPICAL SRV LOADING BAY DIMENSIONS

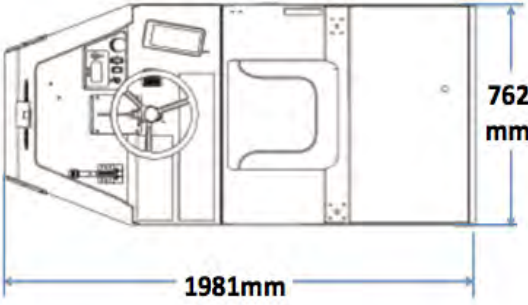

762 mm

1981mm

Motrec MP-240

Small Rigid Vehicle (SRV) the SRV represents light trucks to a maximum load capacity of 10 ton and typically having a single rear axle and either single or dual tyres. Typically used in service areas where small commercial vehicles are preferred.

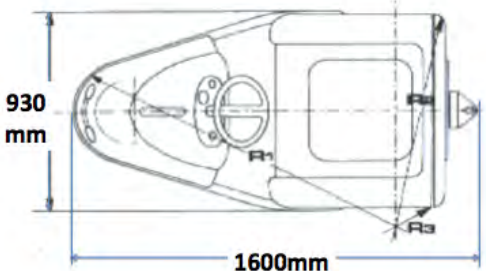

930 mm

1600mm

Dec Bull 2/4

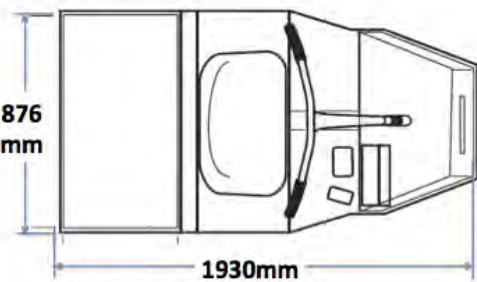

876 mm

1930mm

Cushman 8K

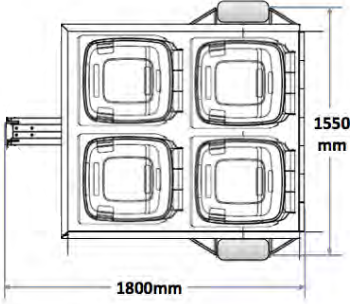

1550 mm

1800mm

Aluminium Trailer – 4 Bins

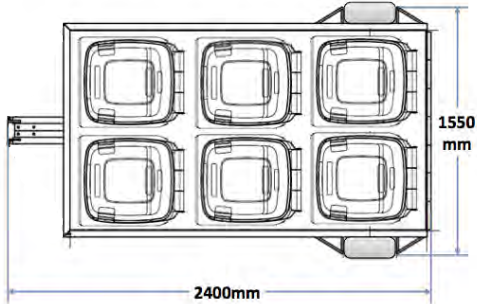

1550 mm

2400mm

Aluminium Trailer – 6 Bins

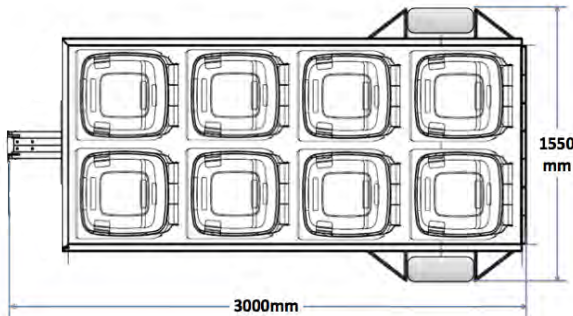

1550 mm

3000mm

Aluminium Trailer – 8 Bins