

SITE PLAN

1:200

northern beaches council

THIS PLAN IS TO BE READ IN CONJUNCTION WITH THE CONDITIONS OF DEVELOPMENT CONSENT

MOD2023/0589

KEY

- CAR ENTRY POINT
- SUN DIRECTION - 22 JUNE
- NOISE SOURCE
- DISTRICT VIEWS OVER ADJOINING HOUSES

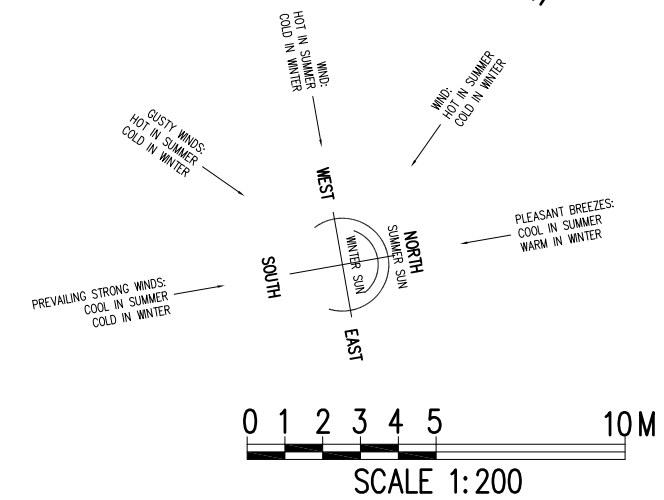

GENERAL NOTES:

- 1 Builder to check and confirm all necessary dimensions on site prior to construction. Do not scale the drawing.
- 2 All dimensions that relate to site boundaries and easements are subject to verification by site survey.
- 3 All work to be in accordance with BUILDING CODE OF AUSTRALIA & to the satisfaction of local council requirements & other authorities.
- 4 All timber construction to be in accordance with the "TIMBER FRAMING" code.
- 5 Any detailing in addition to what is supplied shall be resolved between the owner and the builder to the owner's approval, except for any structural details or design which is to be supplied by Structural Engineer.
- 6 Roof water & sub-soil drainage to be disposed of in the approved manner or as directed by local council inspectors.
- 7 All electrical power & light outlets to be determined by owner.
- 8 Make good and repair all existing finishes damaged by new work. Reuse existing material where possible.

1	ISSUED FOR DA	11/10/23
No.	AMENDMENT	DATE
COPYRIGHT:		
All plans and drawings are subject of copyright and any attempt or actual infringement by using, reproducing or copying same, wholly or in part, without prior written permission will result in legal proceedings.		

DESIGN BY:
MICHAL KORECKY
 21 NALYA ROAD, NARRAWEENA NSW 2099
 ABN: 79 393 130 294
 Email: koreckym@gmail.com www.plansdesign.com.au
 Phone: 99813332, Mob: 0438 148 944

PROJECT:
SUBDIVISION
45 OXFORD FALLS ROAD
BEACON HILL NSW 2100
 CLIENT:
JIRI AND MARCELA ALBRECHT

DATE: 11/10/23	SCALE: AS NOTED
DRAWN: MK	ISSUE: 1
DRAWING Nr : 18080	SHEET: 1

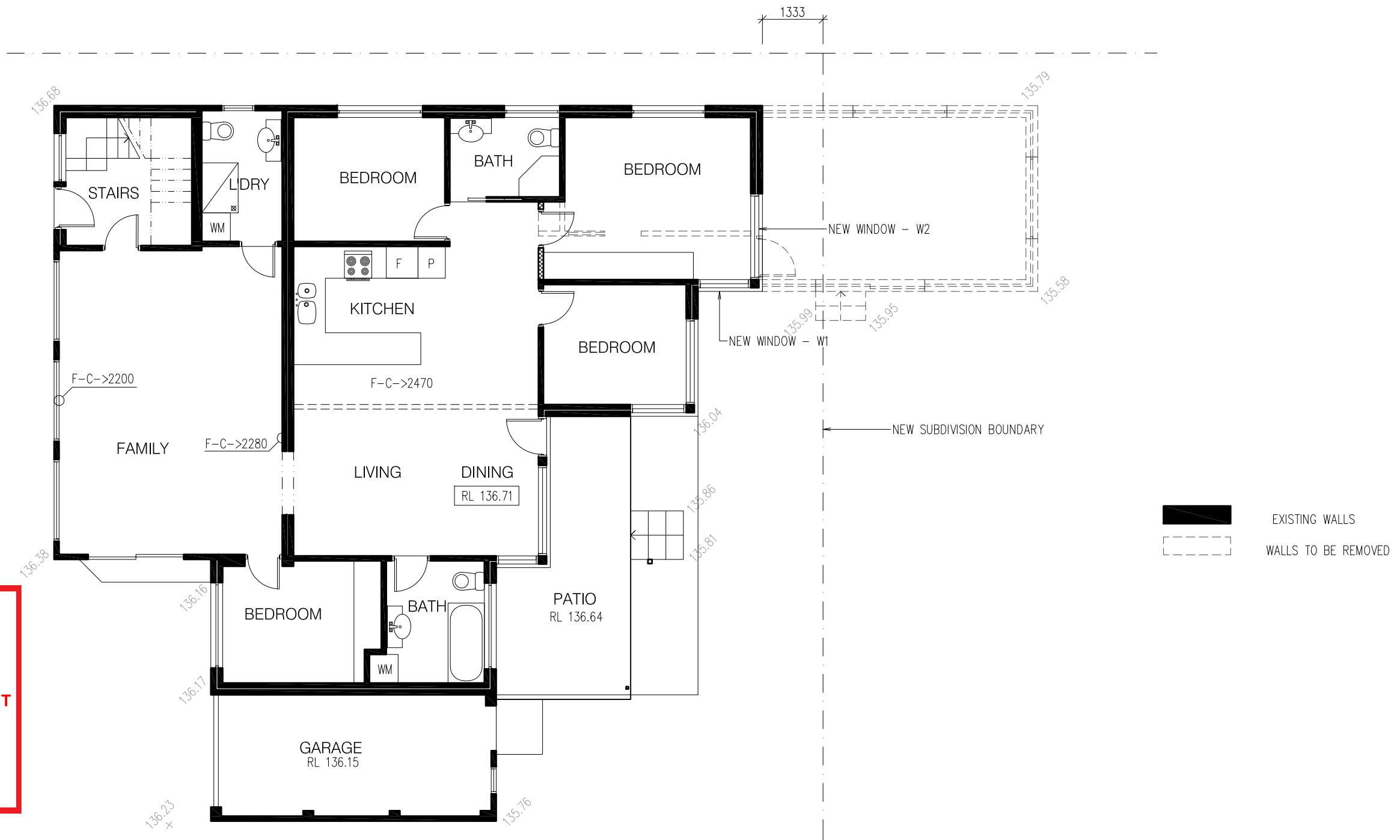

northern beaches council

THIS PLAN IS TO BE READ IN CONJUNCTION WITH THE CONDITIONS OF DEVELOPMENT CONSENT

MOD2023/0589

PROPOSED GROUND FLOOR PLAN
1:100

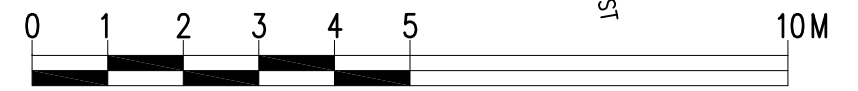
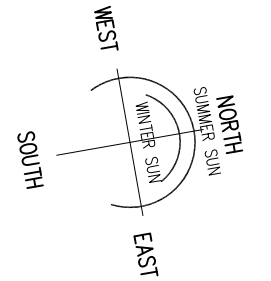

SCALE 1:100

GENERAL NOTES:

- 1 Builder to check and confirm all necessary dimensions on site prior to construction. Do not scale the drawing.
- 2 All dimensions that relate to site boundaries and easements are subject to verification by site survey.
- 3 All work to be in accordance with BUILDING CODE of AUSTRALIA & to the satisfaction of local council requirements & other authorities.
- 4 All timber construction to be in accordance with the "TIMBER FRAMING" code.
- 5 Any detailing in addition to what is supplied shall be resolved between the owner and the builder to the owner's approval, except for any structural details or design which is to be supplied by Structural Engineer.
- 6 Roof water & sub-soil drainage to be disposed of in the approved manner or as directed by local council inspectors.
- 7 All electrical power & light outlets to be determined by owner.
- 8 Make good and repair all existing finishes damaged by new work. Reuse existing material where possible.

No.	ISSUED FOR DA AMENDMENT	11/10/23
DATE		
COPYRIGHT:		
All plans and drawings are subject of copyright and any attempt or actual infringement by using, reproducing or copying same, wholly or in part, without prior written permission will result in legal proceedings.		

DESIGN BY:
MICHAL KORECKY
21 NALYA ROAD, NARRAWEENA NSW 2099
ABN: 79 393 130 294
Email: koreckym@gmail.com www.plansdesign.com.au
Phone: 99813332, Mob: 0438 148 944

PROJECT:
SUBDIVISION
45 OXFORD FALLS ROAD DP 206629
BEACON HILL NSW 2100 LOT 1
CLIENT:
JIRI AND MARCELA ALBRECHT

DATE: 11/10/23	SCALE: AS NOTED
DRAWN: MK	ISSUE: 1
DRAWING Nr : 18080	SHEET: 6

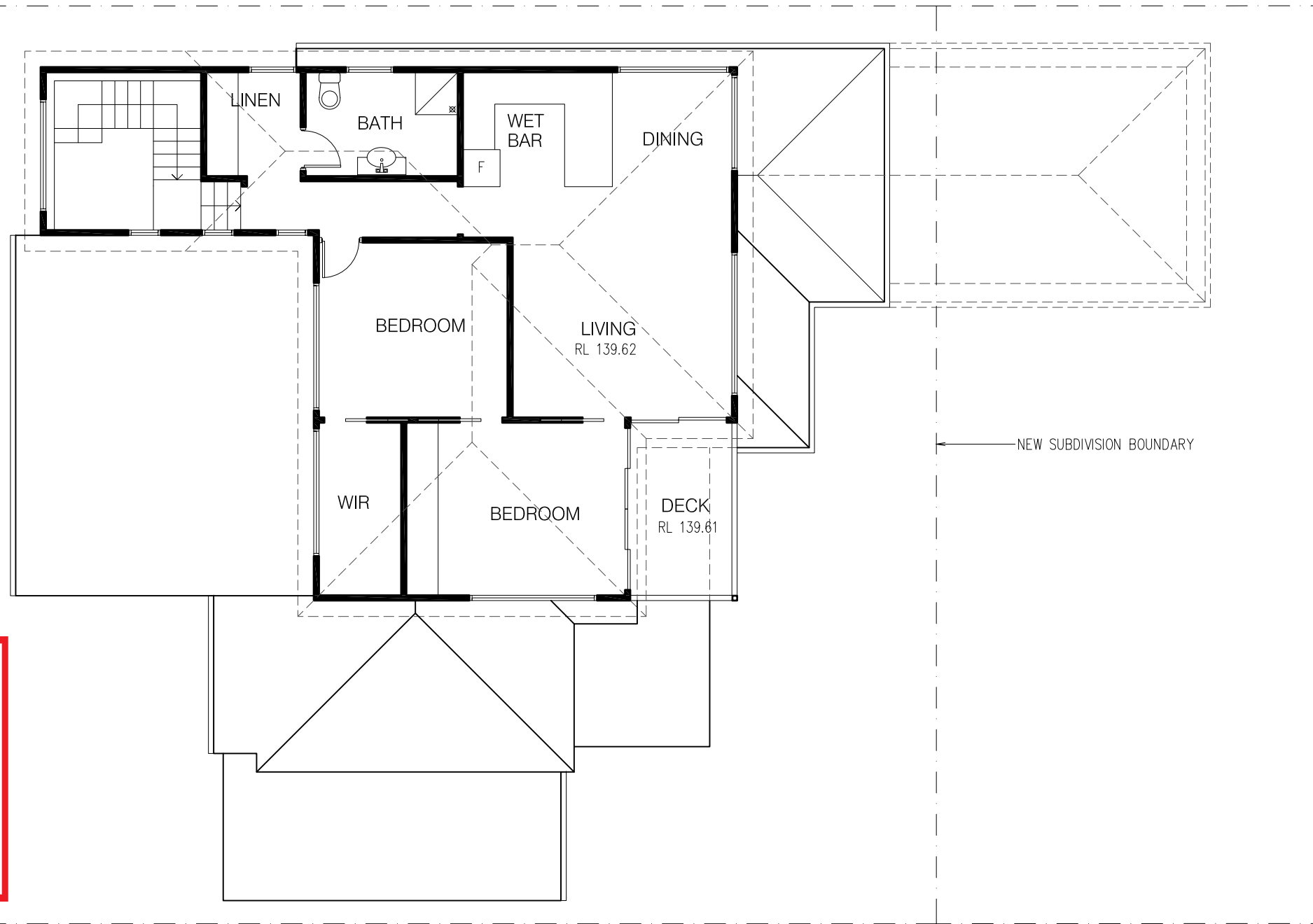

 northern beaches council
THIS PLAN IS TO BE READ IN CONJUNCTION WITH THE CONDITIONS OF DEVELOPMENT CONSENT
MOD2023/0589

PROPOSED FIRST FLOOR PLAN
 1:100

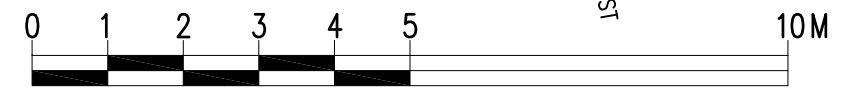
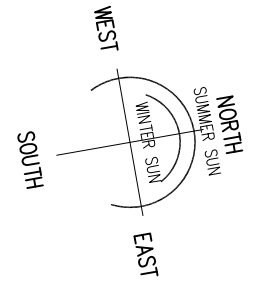

SCALE 1:100

GENERAL NOTES:

- 1 Builder to check and confirm all necessary dimensions on site prior to construction. Do not scale the drawing.
- 2 All dimensions that relate to site boundaries and easements are subject to verification by site survey.
- 3 All work to be in accordance with BUILDING CODE OF AUSTRALIA & to the satisfaction of local council requirements & other authorities.
- 4 All timber construction to be in accordance with the "TIMBER FRAMING" code.
- 5 Any detailing in addition to what is supplied shall be resolved between the owner and the builder to the owner's approval, except for any structural details or design which is to be supplied by Structural Engineer.
- 6 Roof water & sub-soil drainage to be disposed of in the approved manner or as directed by local council inspectors.
- 7 All electrical power & light outlets to be determined by owner.
- 8 Make good and repair all existing finishes damaged by new work. Reuse existing material where possible.

1	ISSUED FOR DA	11/10/23
No.	AMENDMENT	DATE
COPYRIGHT: All plans and drawings are subject of copyright and any attempt or actual infringement by using, reproducing or copying same, wholly or in part, without prior written permission will result in legal proceedings.		

DESIGN BY:
MICHAL KORECKY
 21 NALYA ROAD, NARRAWEENA NSW 2099
 ABN: 79 393 130 294
 Email: koreckym@gmail.com www.plansdesign.com.au
 Phone: 99813332, Mob: 0438 148 944

PROJECT:
SUBDIVISION
45 OXFORD FALLS ROAD DP 206629
BEACON HILL NSW 2100 LOT 1
 CLIENT:
JIRI AND MARCELA ALBRECHT

DATE: 11/10/23	SCALE: AS NOTED
DRAWN: MK	ISSUE: 1
DRAWING Nr : 18080	SHEET: 7

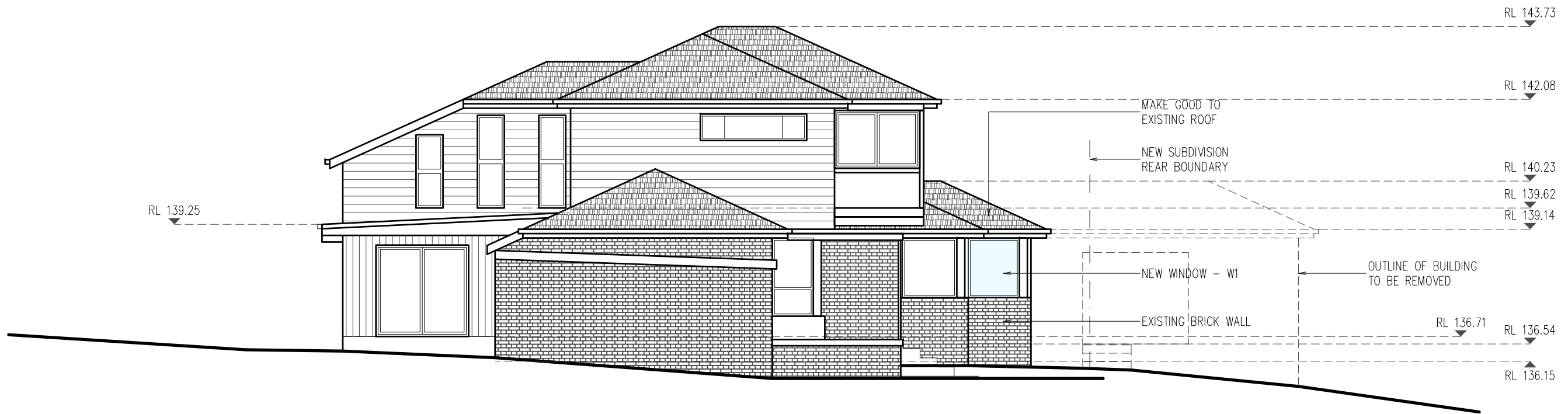

PROPOSED EAST ELEVATION
1:100

northern beaches council

THIS PLAN IS TO BE READ IN CONJUNCTION WITH THE CONDITIONS OF DEVELOPMENT CONSENT

MOD2023/0589

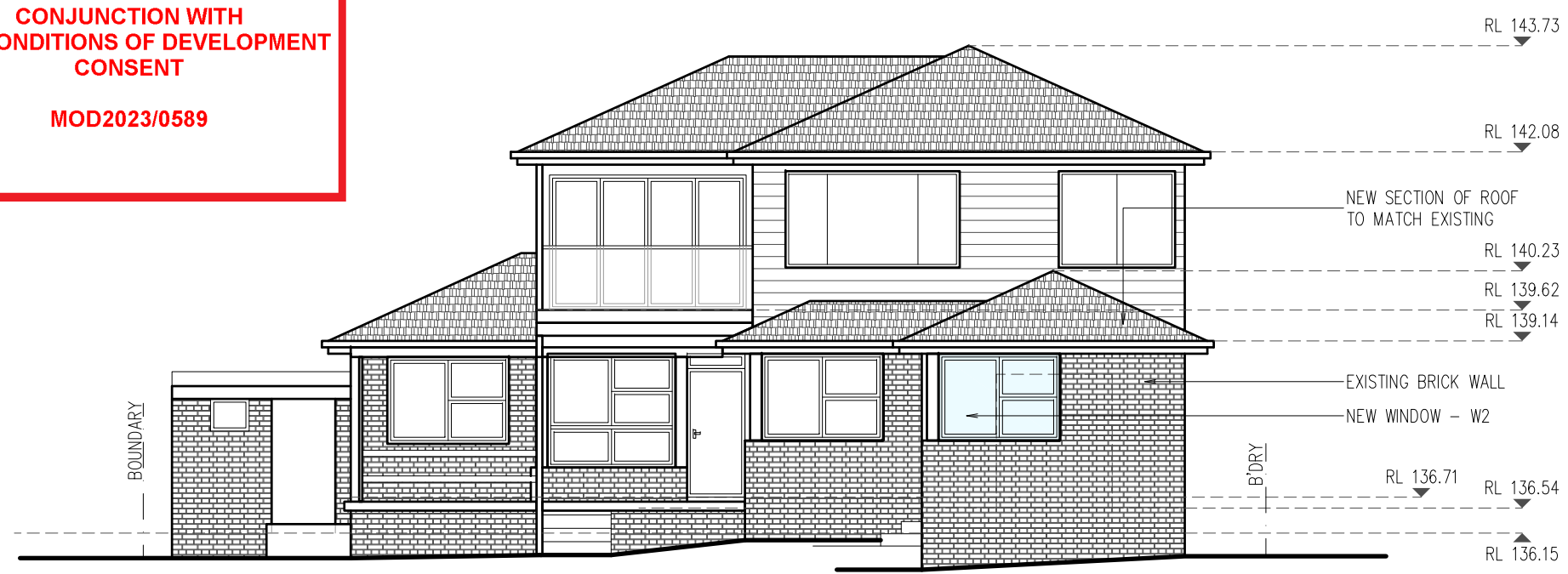

PROPOSED NORTH ELEVATION
1:100

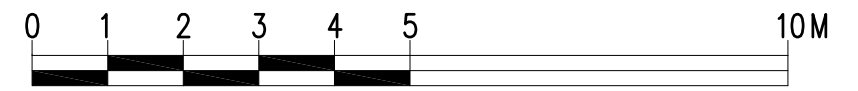

SCALE 1:100

GENERAL NOTES:

- 1 Builder to check and confirm all necessary dimensions on site prior to construction. Do not scale the drawing.
- 2 All dimensions that relate to site boundaries and easements are subject to verification by site survey.
- 3 All work to be in accordance with BUILDING CODE OF AUSTRALIA & to the satisfaction of local council requirements & other authorities.
- 4 All timber construction to be in accordance with the "TIMBER FRAMING" code.
- 5 Any detailing in addition to what is supplied shall be resolved between the owner and the builder to the owner's approval, except for any structural details or design which is to be supplied by Structural Engineer.
- 6 Roof water & sub-soil drainage to be disposed of in the approved manner or as directed by local council inspectors.
- 7 All electrical power & light outlets to be determined by owner.
- 8 Make good and repair all existing finishes damaged by new work. Reuse existing material where possible.

1	ISSUED FOR DA	11/10/23
No.	AMENDMENT	DATE
COPYRIGHT: All plans and drawings are subject of copyright and any attempt or actual infringement by using, reproducing or copying same, wholly or in part, without prior written permission will result in legal proceedings.		

DESIGN BY:
MICHAL KORECKY
21 NALYA ROAD, NARRAWEENA NSW 2099
ABN: 79 393 130 294
Email: koreckym@gmail.com www.plansdesign.com.au
Phone: 99813332, Mob: 0438 148 944

PROJECT:
SUBDIVISION
45 OXFORD FALLS ROAD DP 206629
BEACON HILL NSW 2100 LOT 1
CLIENT:
JIRI AND MARCELA ALBRECHT

DATE: 11/10/23	SCALE: AS NOTED
DRAWN: MK	ISSUE: 1
DRAWING Nr : 18080	SHEET: 8

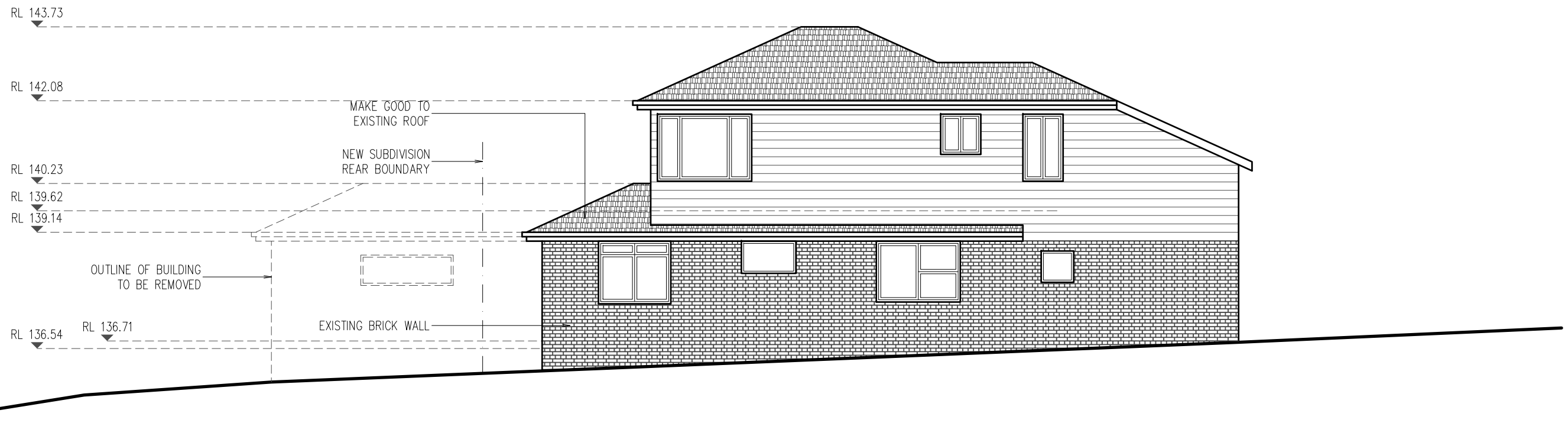

PROPOSED WEST ELEVATION
1:100

NOTES

1. ALL DIMENSIONS ARE IN MILLIMETRES U.N.O. AND SHOULD BE VERIFIED ON SITE BY THE BUILDER WHO WILL BE RESPONSIBLE FOR THE ACCURATE SETTING OUT OF THE JOB. ANY DISCREPANCIES MUST BE RESOLVED PRIOR TO COMMENCEMENT OF WORK.
2. ALL CONSTRUCTION IS TO COMPLY WITH THE RELEVANT SAA BUILDING CODES AND TO THE LOCAL COUNCIL REQUIREMENTS AND OTHER AUTHORITIES CONCERNED.
3. ALL DIMENSIONS THAT RELATE TO SITE BOUNDARIES AND EASEMENTS ARE SUBJECT TO VERIFICATION BY A SITE SURVEY.
4. FIGURED DIMENSIONS TAKE PRECEDENCE OVER SCALED READINGS.
5. ALL TIMBER CONSTRUCTION IS TO BE IN ACCORDANCE WITH THE 'NATIONAL TIMBER FRAMING CODE A.S.1684.
6. ROOF WATER AND SUB SOIL DRAINAGE TO BE DISPOSED OF IN THE APPROVED MANNER OR AS DIRECTED BY LOCAL INSPECTORS.
7. FINAL POSITION OF ALL DOWNPIPES TO BE DECIDED BY ROOF PLUMBER.
8. ANY STRUCTURAL DETAILS OR DESIGN IS TO BE SUPPLIED BY A STRUCTURAL ENGINEER.
9. ALL LEVELS ARE TO AUSTRALIAN HEIGHT DATUM.
10. ALL ELECTRICAL, POWER & LIGHT OUTLETS AS DETERMINED BY OWNER.
11. MAKE GOOD & REPAIR ALL EXISTING FINISHES AFFECTED BY NEW WORK. RE-USE EXISTING MATERIALS WHERE POSSIBLE.
12. ANY DETAILING IN ADDITION TO WHAT IS SUPPLIED ON THIS DRAWING SHALL BE RESOLVED BETWEEN THE OWNER & THE BUILDER.



THIS PLAN IS TO BE READ IN CONJUNCTION WITH THE CONDITIONS OF DEVELOPMENT CONSENT
MOD2023/0589

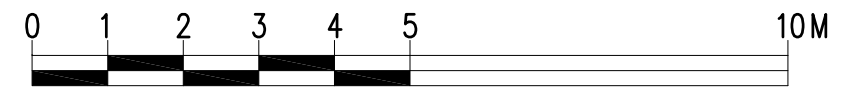

SCALE 1:100

GENERAL NOTES:

- 1 Builder to check and confirm all necessary dimensions on site prior to construction. Do not scale the drawing.
- 2 All dimensions that relate to site boundaries and easements are subject to verification by site survey.
- 3 All work to be in accordance with BUILDING CODE OF AUSTRALIA & to the satisfaction of local council requirements & other authorities.
- 4 All timber construction to be in accordance with the "TIMBER FRAMING" code.
- 5 Any detailing in addition to what is supplied shall be resolved between the owner and the builder to the owner's approval, except for any structural details or design which is to be supplied by Structural Engineer.
- 6 Roof water & sub-soil drainage to be disposed of in the approved manner or as directed by local council inspectors.
- 7 All electrical power & light outlets to be determined by owner.
- 8 Make good and repair all existing finishes damaged by new work. Reuse existing material where possible.

1	ISSUED FOR DA	11/10/23
No.	AMENDMENT	DATE
COPYRIGHT: All plans and drawings are subject of copyright and any attempt or actual infringement by using, reproducing or copying same, wholly or in part, without prior written permission will result in legal proceedings.		

DESIGN BY:
MICHAL KORECKY
 21 NALYA ROAD, NARRAWEENA NSW 2099
 ABN: 79 393 130 294
 Email: koreckym@gmail.com www.plansdesign.com.au
 Phone: 99813332, Mob: 0438 148 944

PROJECT:
SUBDIVISION
45 OXFORD FALLS ROAD DP 206629
BEACON HILL NSW 2100 LOT 1
 CLIENT:
JIRI AND MARCELA ALBRECHT

DATE: 11/10/23	SCALE: AS NOTED
DRAWN: MK	ISSUE: 1
DRAWING Nr : 18080	SHEET: 9

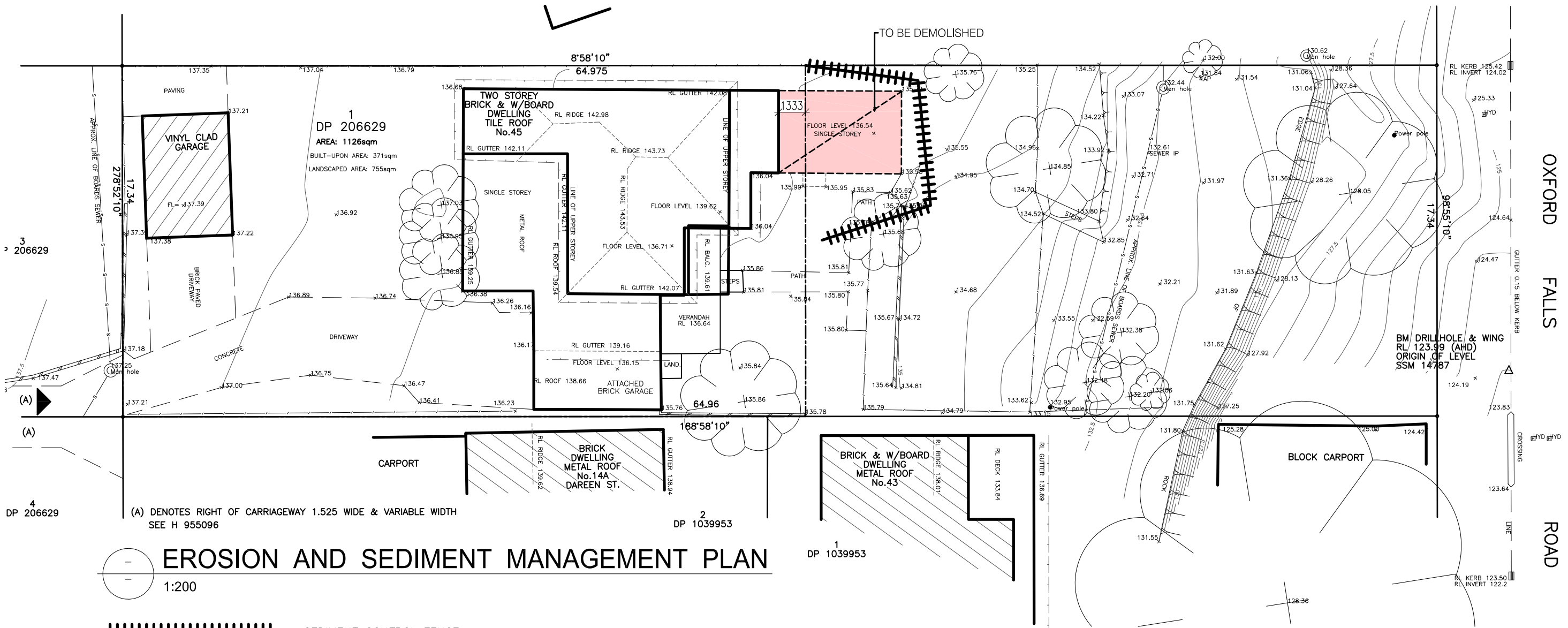

EROSION AND SEDIMENT MANAGEMENT PLAN

1:200

SEDIMENT CONTROL FENCE

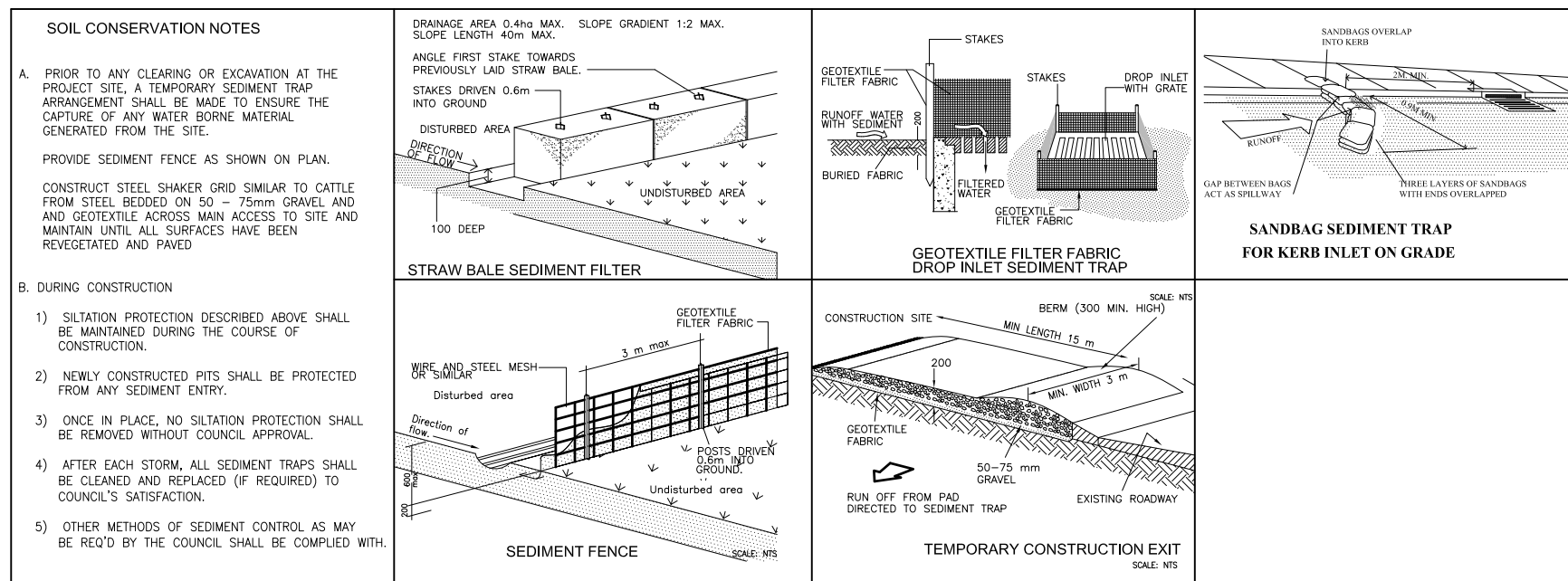

northern beaches council

THIS PLAN IS TO BE READ IN CONJUNCTION WITH THE CONDITIONS OF DEVELOPMENT CONSENT

MOD2023/0589

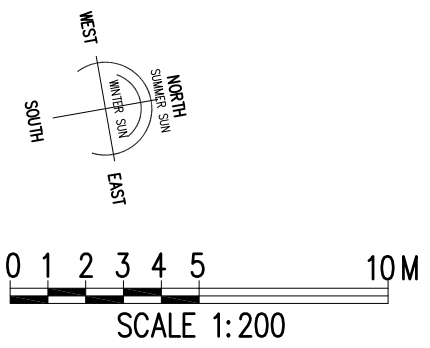

GENERAL NOTES:

- 1 Builder to check and confirm all necessary dimensions on site prior to construction. Do not scale the drawing.
- 2 All dimensions that relate to site boundaries and easements are subject to verification by site survey.
- 3 All work to be in accordance with BUILDING CODE OF AUSTRALIA & to the satisfaction of local council requirements & other authorities.
- 4 All timber construction to be in accordance with the "TIMBER FRAMING" code.
- 5 Any detailing in addition to what is supplied shall be resolved between the owner and the builder to the owner's approval, except for any structural details or design which is to be supplied by Structural Engineer.
- 6 Roof water & sub-soil drainage to be disposed of in the approved manner or as directed by local council inspectors.
- 7 All electrical power & light outlets to be determined by owner.
- 8 Make good and repair all existing finishes damaged by new work. Reuse existing material where possible.

1	ISSUED FOR DA	11/10/23
No.	AMENDMENT	DATE
COPYRIGHT: All plans and drawings are subject of copyright and any attempt or actual infringement by using, reproducing or copying same, wholly or in part, without prior written permission will result in legal proceedings.		

DESIGN BY:
MICHAL KORECKY
21 NALYA ROAD, NARRAWEENA NSW 2099
ABN: 79 393 130 294
Email: koreckym@gmail.com www.plansdesign.com.au
Phone: 99813332, Mob: 0438 148 944

PROJECT:
SUBDIVISION
45 OXFORD FALLS ROAD DP 206629
BEACON HILL NSW 2100 LOT 1
CLIENT:
JIRI AND MARCELA ALBRECHT

DATE: 11/10/23	SCALE: AS NOTED
DRAWN: MK	ISSUE: 1
DRAWING Nr : 18080	SHEET: 10

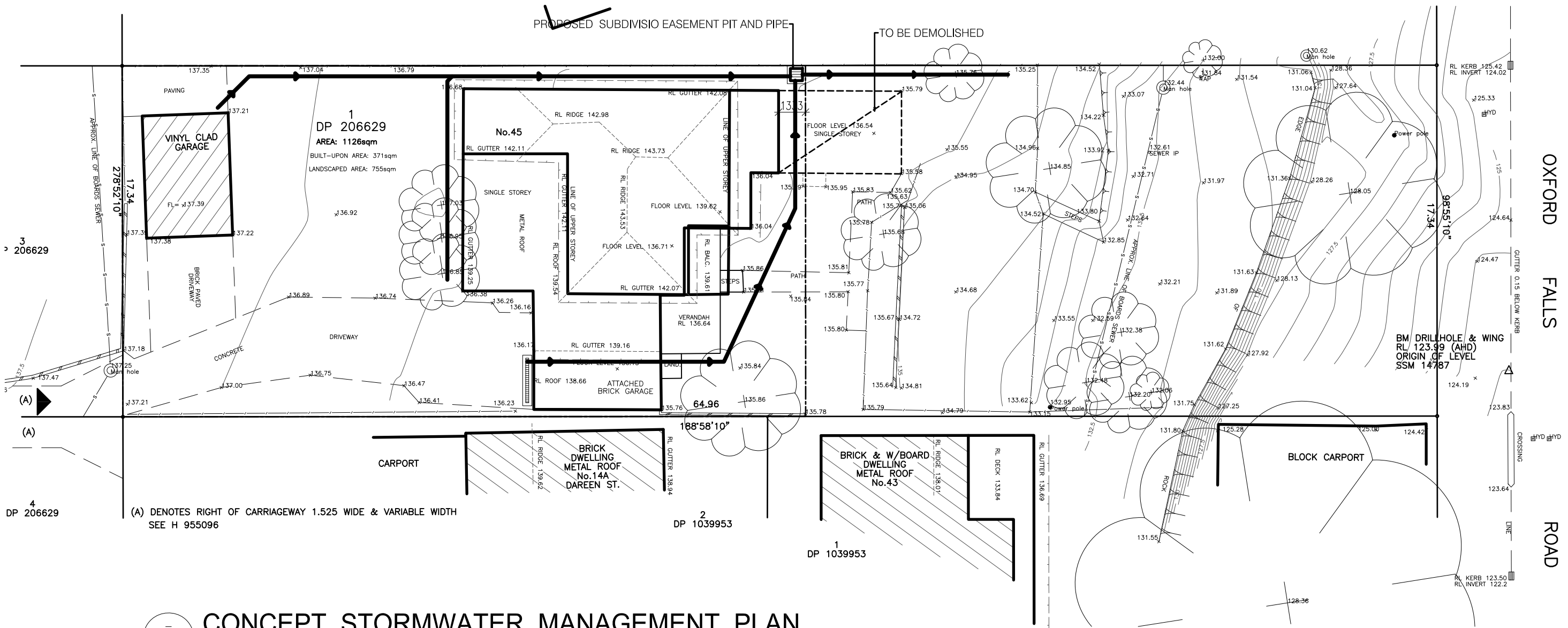

CONCEPT STORMWATER MANAGEMENT PLAN

1:200

ALL EXISTING DRAINAGE PIPE TO BE CHECKED ON SITE DURING CONSTRUCTION, IF INADEQUATE, NEW $\phi 100$ uPVC SEWER GRADE PIPES TO BE INSTALLED

northern beaches council

THIS PLAN IS TO BE READ IN CONJUNCTION WITH THE CONDITIONS OF DEVELOPMENT CONSENT

MOD2023/0589

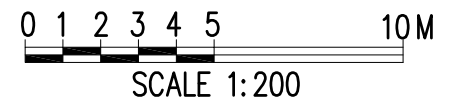
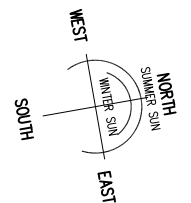

GENERAL NOTES:

- 1 Builder to check and confirm all necessary dimensions on site prior to construction. Do not scale the drawing.
- 2 All dimensions that relate to site boundaries and easements are subject to verification by site survey.
- 3 All work to be in accordance with BUILDING CODE OF AUSTRALIA & to the satisfaction of local council requirements & other authorities.
- 4 All timber construction to be in accordance with the "TIMBER FRAMING" code.
- 5 Any detailing in addition to what is supplied shall be resolved between the owner and the builder to the owner's approval, except for any structural details or design which is to be supplied by Structural Engineer.
- 6 Roof water & sub-soil drainage to be disposed of in the approved manner or as directed by local council inspectors.
- 7 All electrical power & light outlets to be determined by owner.
- 8 Make good and repair all existing finishes damaged by new work. Reuse existing material where possible.

1	ISSUED FOR DA	11/10/23
No.	AMENDMENT	DATE
COPYRIGHT: All plans and drawings are subject of copyright and any attempt or actual infringement by using, reproducing or copying same, wholly or in part, without prior written permission will result in legal proceedings.		

DESIGN BY:
MICHAL KORECKY
21 NALYA ROAD, NARRAWEENA NSW 2099
ABN: 79 393 130 294
Email: koreckym@gmail.com www.plansdesign.com.au
Phone: 99813332, Mob: 0438 148 944

PROJECT:
SUBDIVISION 45 OXFORD FALLS ROAD BEACON HILL NSW 2100
DP 206629 LOT 1
CLIENT:
JIRI AND MARCELA ALBRECHT

DATE: 11/10/23	SCALE: AS NOTED
DRAWN: MK	ISSUE: 1
DRAWING Nr: 18080	SHEET: 11