

ABBREVIATIONS

- AH---ACCESS HATCH
- DDO---DISH DRAIN OUTLET
- CO---CLEAR OUT
- DCP---DISCHARGE CONTROL PIT
- DP---DOWNPIPE
- FFL---FINISH FLOOR LEVEL
- FW---FLOOR WASTE
- GL---GROUND FLOOR LEVEL
- IL---INVERT LEVEL
- OSD---ON SITE DETENTION
- PD---PLANTERS DRAIN
- PFO---PLANTER FLOOR OUTLET
- PP---PLANTER PIT
- RH---RAINWATER HEAD
- RP---RELN PIT
- RO---ROOF OUTLET
- SDO---STRIP DRAIN OUTLET
- SIP---SURFACE INLET PIT
- STP---SILT TRAP PIT
- SP---SPREADER
- TD---TUN DISH

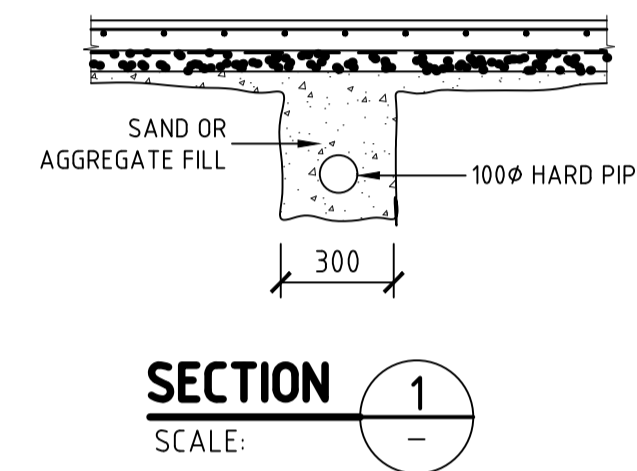
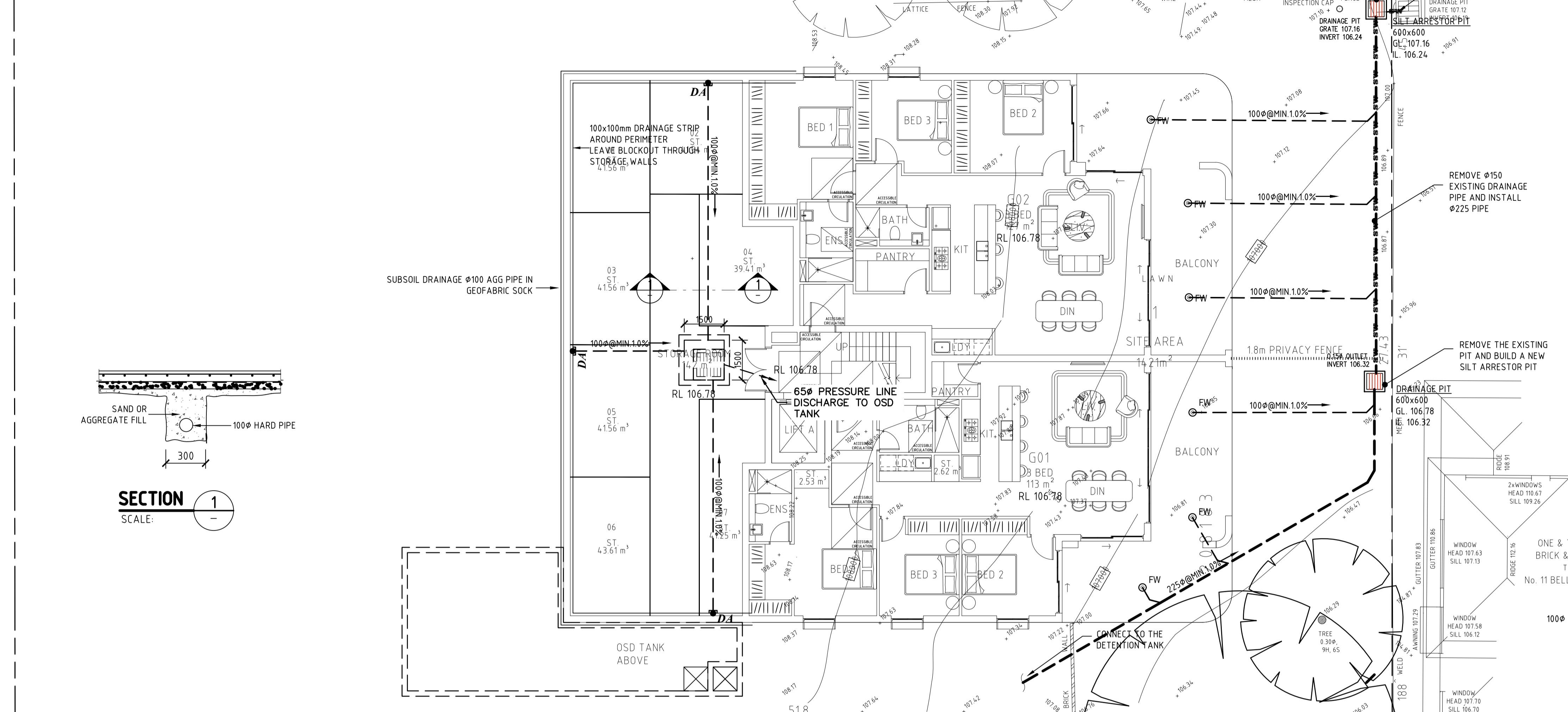

SITE AND GROUND FLOOR STORMWATER DRAINAGE CONCEPT PLAN
SCALE: 1:100

STANDARD PUMP OUT DESIGN NOTES:

THE PUMP OUT SYSTEM SHALL BE DESIGNED TO OPERATE IN THE FOLLOWING MANNER:

- THE PUMPS SHALL BE PROGRAMMED TO WORK ALTERNATELY SO AS TO ALLOW BOTH PUMPS TO HAVE AN EQUAL OPERATION LOAD AND PUMP LIFE.
- A LOW LEVEL FLOAT SHALL BE PROVIDED TO ENSURE THAT THE MINIMUM REQUIREMENT WATER LEVEL IS MAINTAINED WITHIN THE SUMP AREA OF THE BELOW GROUND TANK. IN THIS REGARD THE FLOAT WILL FUNCTION AS AN OFF SWITCH FOR THE PUMPS.
- A SECTION FLOAT SHALL BE PROVIDED AT A HIGHER LEVEL, APPROXIMATELY 300mm ABOVE THE MINIMUM WATER LEVEL, WHEREBY ONE OF THE PUMPS WILL OPERATE AND DRAIN THE TANK TO THE LEVEL OF THE LOW LEVEL FLOAT.
- A THIRD FLOAT SHALL BE PROVIDED AT A HIGH LEVEL, WHICH IS APPROXIMATELY THE ROOF LEVEL OF THE BELOW GROUND TANK. THIS FLOAT SHOULD START THE OTHER PUMP THAT IS NOT OPERATING AND ACTIVATE THE ALARM.
- AN ALARM SYSTEM SHALL BE PROVIDED WITH A FLASHING STORE LIGHT AND A PUMP FAILURE WARNING SIGN WHICH AREA TO BE LOCATED AT THE DRIVEWAY ENTRANCE TO THE BASEMENT LEVEL. THE ALARM SYSTEM SHALL BE PROVIDED WITH A BATTERY BACK-UP IN CASE OF POWER FAILURE.

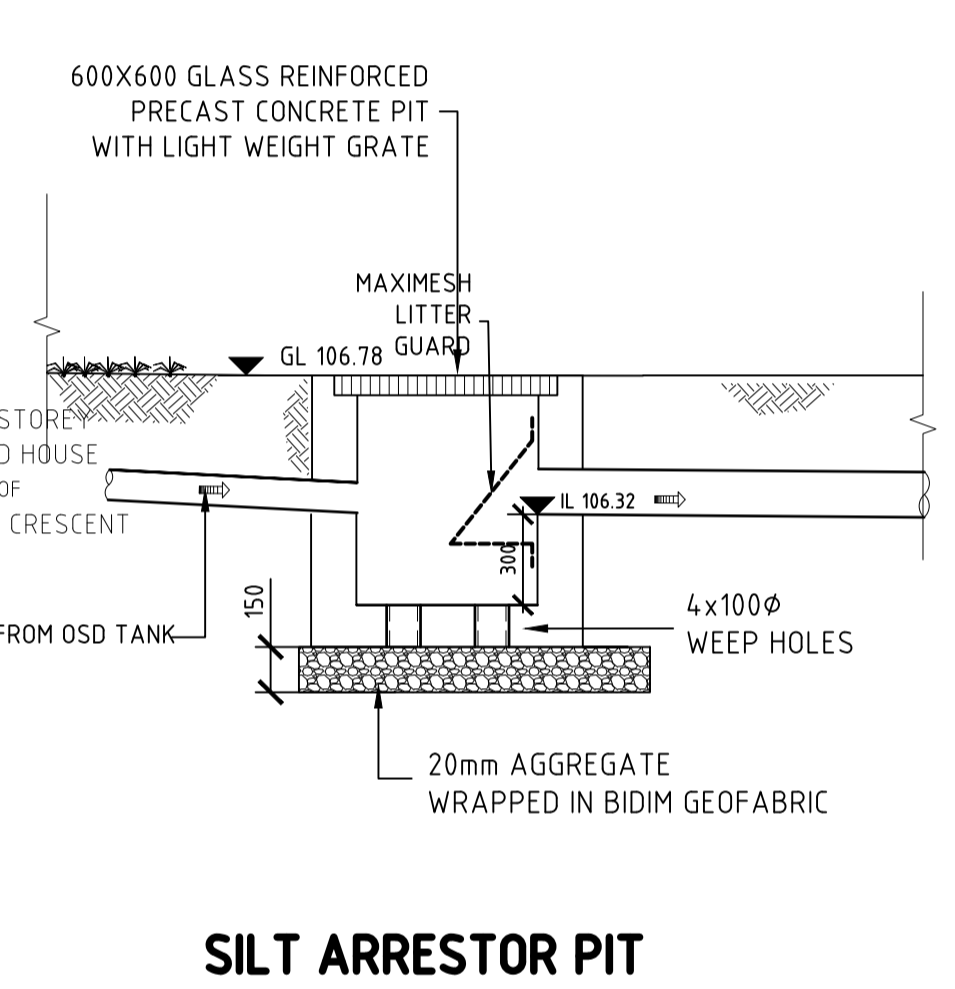
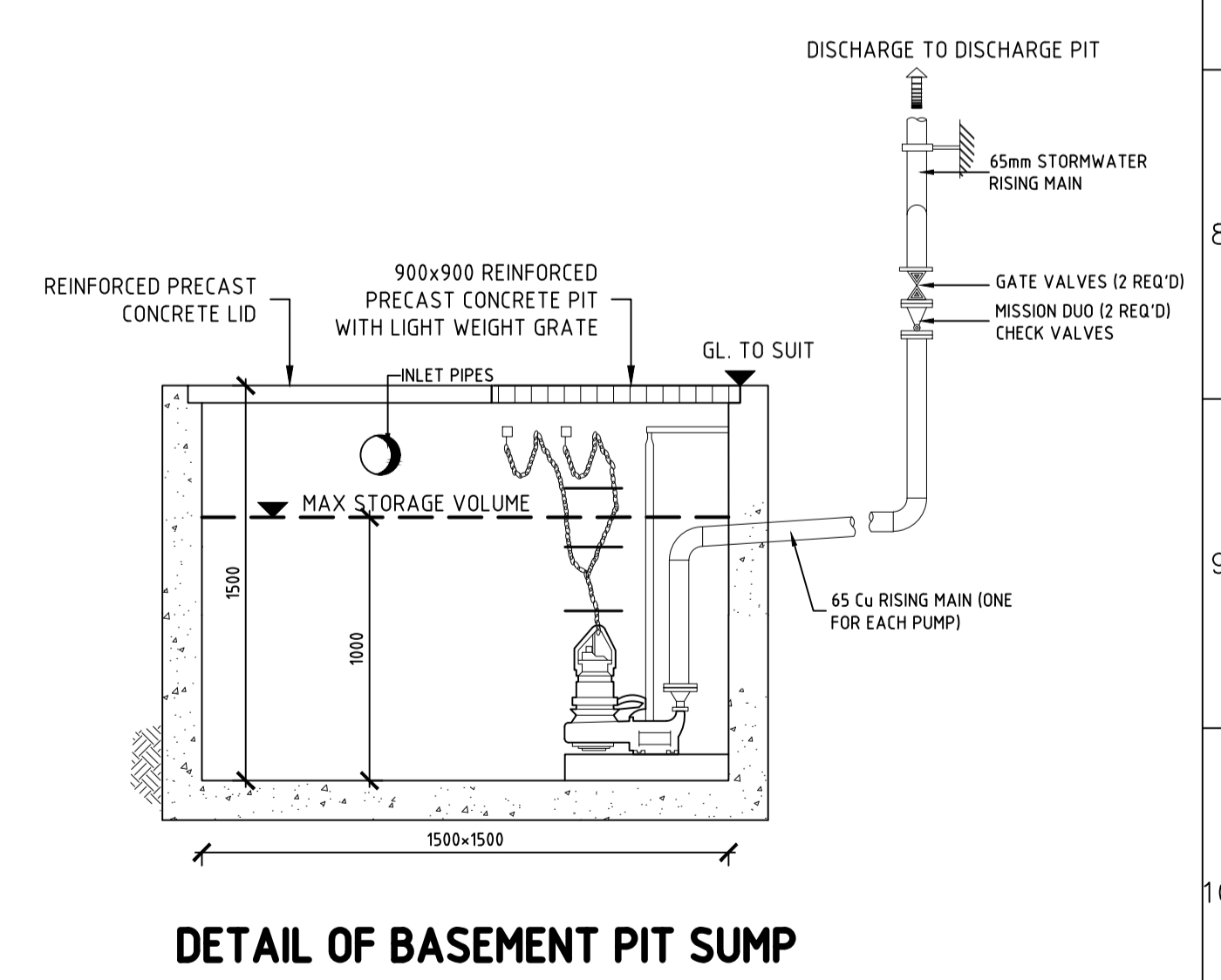
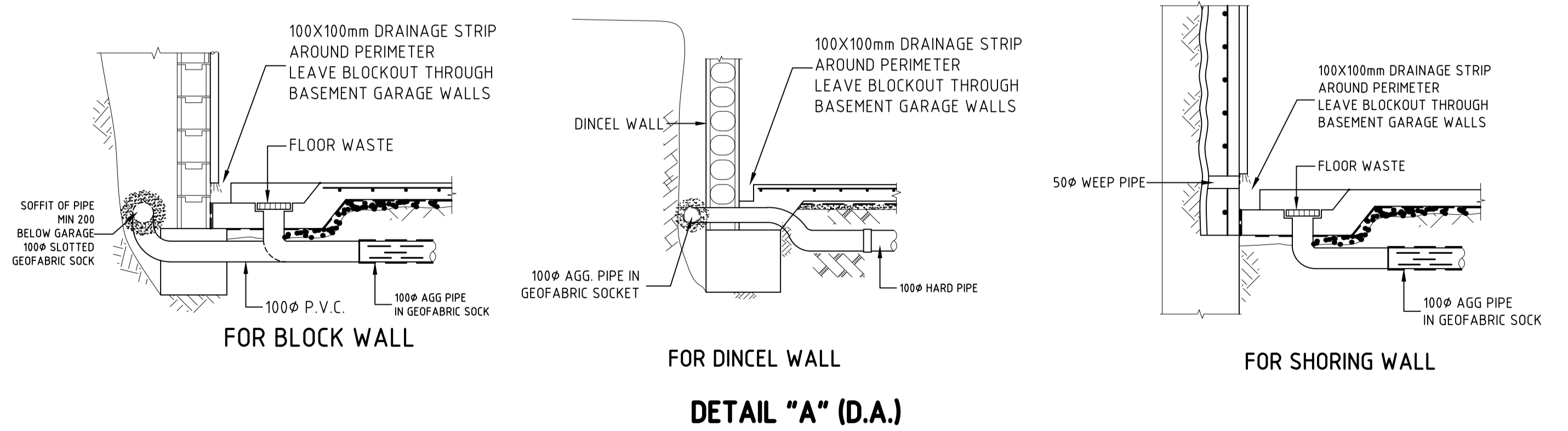

REV.	DATE	BY	CHECKED	AMENDMENTS
A	01 DEC 22	M.W.	S.W.W.	PRELIMINARY ISSUE

LMW DESIGN GROUP P/L
 Building Consultants and Structural Engineers
 15 Woodlands Ave. Lugarno NSW 2210
 Phone: (02) 9533 5778
 Fax: (02) 9543 1058
 Mobile: 0418 285 592
 Email: lmwdesigngroup@gmail.com

JOB NAME:
PROPOSED NEW DEVELOPMENT AT 69 MELWOOD AVE FORESTVILLE
 CLIENT, ARCHITECT:
ANTOINE GITTANY
 DRAWING TITLE:
SITE AND GROUND FLOOR STORMWATER DRAINAGE CONCEPT PLAN

No. IN SET	JOB No	2096.22	DRG. No	REV
			D1	A
SCALE	DESIGNED	DRAWN	DATE	No.
N.T.S.	S.W.W.	M.W.	DEC.2022	

APPROVED BY:
STEVEN WATERS
 B.E., M.ENG.SC.
 M.I.E. AUSTR., C.P. ENG., NPER-3
 REG. No. 417092
 CIVIL AND STRUCTURAL



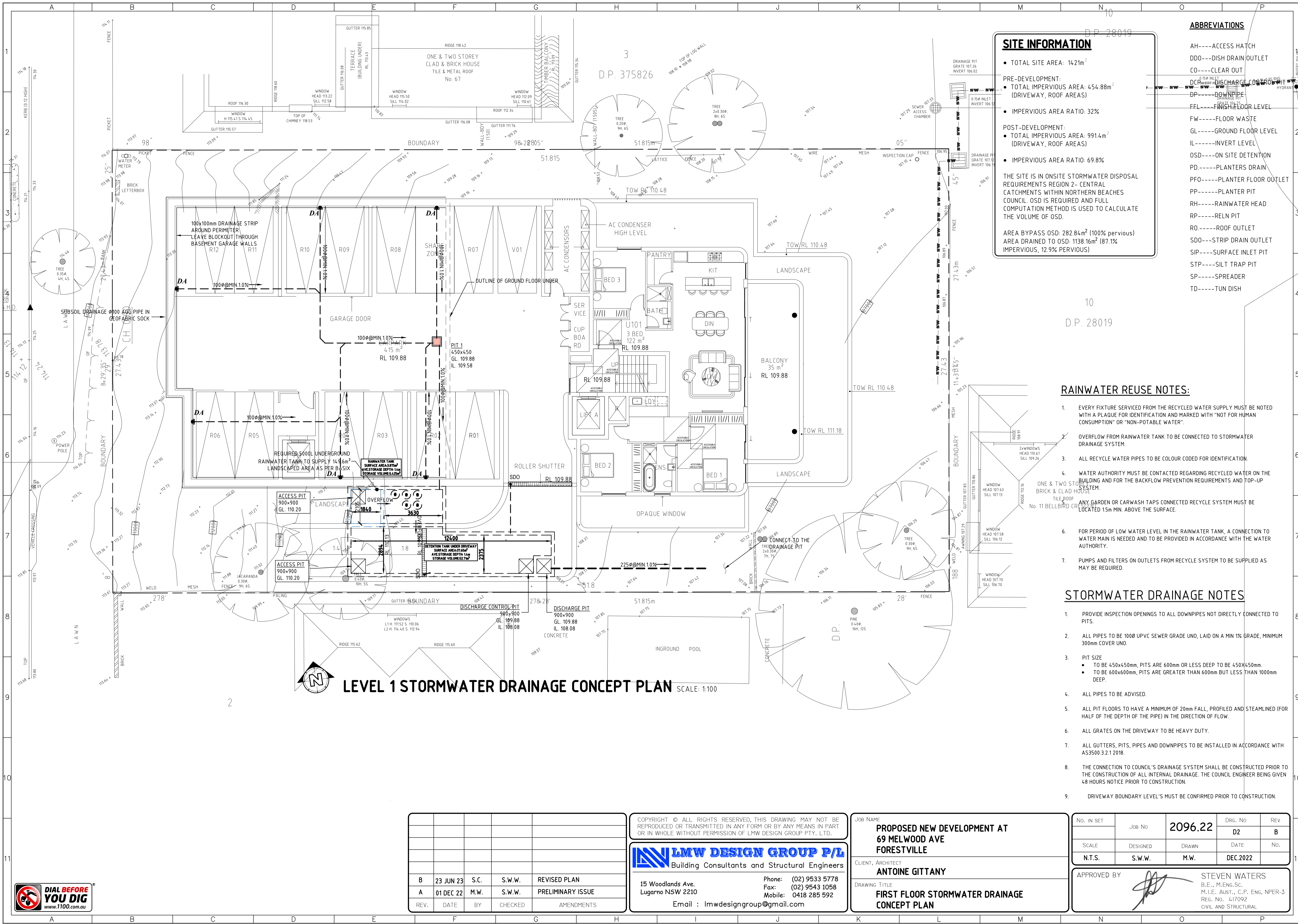

LEVEL 1 STORMWATER DRAINAGE CONCEPT PLAN SCALE: 1:100

SITE INFORMATION

• TOTAL SITE AREA: 1421m²

PRE-DEVELOPMENT:
 • TOTAL IMPERVIOUS AREA: 454.88m² (DRIVEWAY, ROOF AREAS)

• IMPERVIOUS AREA RATIO: 32%

POST-DEVELOPMENT:
 • TOTAL IMPERVIOUS AREA: 991.4m² (DRIVEWAY, ROOF AREAS)

• IMPERVIOUS AREA RATIO: 69.8%

THE SITE IS IN ONSITE STORMWATER DISPOSAL REQUIREMENTS REGION 2- CENTRAL CATCHMENTS WITHIN NORTHERN BEACHES COUNCIL. OSD IS REQUIRED AND FULL COMPUTATION METHOD IS USED TO CALCULATE THE VOLUME OF OSD.

AREA BYPASS OSD: 282.84m² (100% pervious)
 AREA DRAINED TO OSD: 1138.16m² (87.1% IMPERVIOUS, 12.9% PERVIOUS)

ABBREVIATIONS

- AH----ACCESS HATCH
- DDO----DISH DRAIN OUTLET
- CO----CLEAR OUT
- DCP----DISCHARGE CONTROL PIT
- DP----DOWNPIPE
- FEL----FINISH FLOOR LEVEL
- FW----FLOOR WASTE
- GL----GROUND FLOOR LEVEL
- IL----INVERT LEVEL
- OSD----ON SITE DETENTION
- PD----PLANTERS DRAIN
- PFO----PLANTER FLOOR OUTLET
- PP----PLANTER PIT
- RH----RAINWATER HEAD
- RP----RELN PIT
- RO----ROOF OUTLET
- SDO---STRIP DRAIN OUTLET
- SIP----SURFACE INLET PIT
- STP----SILT TRAP PIT
- SP----SPREADER
- TD----TUN DISH

RAINWATER REUSE NOTES:

1. EVERY FIXTURE SERVICED FROM THE RECYCLED WATER SUPPLY MUST BE NOTED WITH A PLAQUE FOR IDENTIFICATION AND MARKED WITH "NOT FOR HUMAN CONSUMPTION" OR "NON-POTABLE WATER".
2. OVERFLOW FROM RAINWATER TANK TO BE CONNECTED TO STORMWATER DRAINAGE SYSTEM.
3. ALL RECYCLE WATER PIPES TO BE COLOUR CODED FOR IDENTIFICATION.
4. WATER AUTHORITY MUST BE CONTACTED REGARDING RECYCLED WATER ON THE BUILDING AND FOR THE BACKFLOW PREVENTION REQUIREMENTS AND TOP-UP SYSTEM.
5. ANY GARDEN OR CARWASH TAPS CONNECTED RECYCLE SYSTEM MUST BE LOCATED 1.5m MIN. ABOVE THE SURFACE.
6. FOR PERIOD OF LOW WATER LEVEL IN THE RAINWATER TANK, A CONNECTION TO WATER MAIN IS NEEDED AND TO BE PROVIDED IN ACCORDANCE WITH THE WATER AUTHORITY.
7. PUMPS AND FILTERS ON OUTLETS FROM RECYCLE SYSTEM TO BE SUPPLIED AS MAY BE REQUIRED.

STORMWATER DRAINAGE NOTES

1. PROVIDE INSPECTION OPENINGS TO ALL DOWNPIPES NOT DIRECTLY CONNECTED TO PITS.
2. ALL PIPES TO BE 100Ø UPVC SEWER GRADE UNO, LAID ON A MIN 1% GRADE, MINIMUM 300mm COVER UNO.
3. PIT SIZE
 - TO BE 450x450mm, PITS ARE 600mm OR LESS DEEP TO BE 450x450mm.
 - TO BE 600x600mm, PITS ARE GREATER THAN 600mm BUT LESS THAN 1000mm DEEP.
4. ALL PIPES TO BE ADVISED.
5. ALL PIT FLOORS TO HAVE A MINIMUM OF 20mm FALL, PROFILED AND STEAMLINED (FOR HALF OF THE DEPTH OF THE PIPE) IN THE DIRECTION OF FLOW.
6. ALL GRATES ON THE DRIVEWAY TO BE HEAVY DUTY.
7. ALL GUTTERS, PITS, PIPES AND DOWNPIPES TO BE INSTALLED IN ACCORDANCE WITH AS3500.3.2.1 2018.
8. THE CONNECTION TO COUNCIL'S DRAINAGE SYSTEM SHALL BE CONSTRUCTED PRIOR TO THE CONSTRUCTION OF ALL INTERNAL DRAINAGE. THE COUNCIL ENGINEER BEING GIVEN 48 HOURS NOTICE PRIOR TO CONSTRUCTION.
9. DRIVEWAY BOUNDARY LEVEL'S MUST BE CONFIRMED PRIOR TO CONSTRUCTION.

REV.	DATE	BY	CHECKED	AMENDMENTS
B	23 JUN 23	S.C.	S.W.W.	REVISED PLAN
A	01 DEC 22	M.W.	S.W.W.	PRELIMINARY ISSUE

Copyright © ALL RIGHTS RESERVED. THIS DRAWING MAY NOT BE REPRODUCED OR TRANSMITTED IN ANY FORM OR BY ANY MEANS IN PART OR IN WHOLE WITHOUT PERMISSION OF LMW DESIGN GROUP PTY. LTD.

LMW DESIGN GROUP P/L
 Building Consultants and Structural Engineers

15 Woodlands Ave.
 Lugarno NSW 2210

Phone: (02) 9533 5778
 Fax: (02) 9543 1058
 Mobile: 0418 285 592
 Email: lmwdesigngroup@gmail.com

JOB NAME
**PROPOSED NEW DEVELOPMENT AT
 69 MELWOOD AVE
 FORESTVILLE**

CLIENT, ARCHITECT
ANTOINE GITTANY

DRAWING TITLE
**FIRST FLOOR STORMWATER DRAINAGE
 CONCEPT PLAN**

No. in SET	Job No	2096.22	DRG. No	REV
			D2	B
SCALE	DESIGNED	DRAWN	DATE	No.
N.T.S.	S.W.W.	M.W.	DEC.2022	

APPROVED BY
 **STEVEN WATERS**
 B.E., M.Eng.Sc.
 M.I.E. (AUST.), C.P. Eng., NFER-3
 REG. No. 417092
 CIVIL AND STRUCTURAL



ON-SITE DETENTION CALCULATION:

1. COUNCIL REQUIREMENT FOR PSD:

DESIGN ARI: 5 YRS, 20 YRS, 100 YRS
 PERMISSIBLE SITE DISCHARGE: THE PEAK 5-YEAR ARI STORM EVENT FOR THE PRE-DEVELOPMENT BASED ON 0%PRE-DEVELOPMENT SITE IMPERVIOUS AREA

2. TRIANGULAR HYDROGRAPH METHOD (USING DRAINS):

PRE-DEVELOPMENT

STORM	PEAK FLOW (m ³ /s)
AR&R 5yrs, 5min STORM, AVE. 161mm/h, ZONE 1	0.014
AR&R 5yrs, 10min STORM, AVE. 125mm/h, ZONE 1	0.026
AR&R 5yrs, 20min STORM, AVE. 92.9mm/h, ZONE 1	0.039
AR&R 5yrs, 30min STORM, AVE. 76.4mm/h, ZONE 1	0.039
AR&R 5yrs, 60min STORM, AVE. 52.7mm/h, ZONE 1	0.036

STORM	PEAK FLOW (m ³ /s)
AR&R 100yrs, 5min STORM, AVE. 268mm/h, ZONE 1	0.035
AR&R 100yrs, 10min STORM, AVE. 211mm/h, ZONE 1	0.060
AR&R 100yrs, 20min STORM, AVE. 161mm/h, ZONE 1	0.079
AR&R 100yrs, 30min STORM, AVE. 135mm/h, ZONE 1	0.076
AR&R 100yrs, 60min STORM, AVE. 94.2mm/h, ZONE 1	0.066

FROM THE TABLES ABOVE, THE PERMISSIBLE SITE DISCHARGE: 39 L/S (0% PRE-DEVELOPMENT SITE IMPERVIOUS AREA DURING AR&R 5 YEAR, 30 MINUTES AVERAGE 76.4 mm/h, ZONE 1) (USING DRAINS)

3. DESIGNED ARI FOR OSD: 100YRS POST-DEVELOPMENT

STORM	PEAK FLOW (m ³ /s)
AR&R 100yrs, 5min STORM, AVE. 268mm/h, ZONE 1	0.013
AR&R 100yrs, 10min STORM, AVE. 211mm/h, ZONE 1	0.017
AR&R 100yrs, 20min STORM, AVE. 161mm/h, ZONE 1	0.020
AR&R 100yrs, 30min STORM, AVE. 135mm/h, ZONE 1	0.021
AR&R 100yrs, 60min STORM, AVE. 94.2mm/h, ZONE 1	0.023

BYPASS

STORM	PEAK FLOW (m ³ /s)
AR&R 100yrs, 5min STORM, AVE. 248mm/h, ZONE 1	0.007
AR&R 100yrs, 10min STORM, AVE. 193mm/h, ZONE 1	0.012
AR&R 100yrs, 20min STORM, AVE. 145mm/h, ZONE 1	0.016
AR&R 100yrs, 30min STORM, AVE. 119mm/h, ZONE 1	0.015
AR&R 100yrs, 60min STORM, AVE. 82.6mm/h, ZONE 1	0.013

DESIGNED OUTFLOW FROM THE SITE: 36L/s
 REQUIRED OSD VOLUME: 52.58m³

MAINTENANCE ACTION	FREQUENCY	RESPONSIBILITY	PROCEDURE
Outlets			
Inspect & remove any blockage of orifices	Six monthly	Owner	Remove grate & screen to inspect orifice. See plan for location of outlets
Check attachment of orifice plates to wall of chamber and/or pit (gaps less than 5 mm)	Annually	Maintenance Contractor	Remove grate and screen. Ensure plates are mounted securely, tighten fixings if required. Seal gaps as required.
Check orifice diameters are correct and retain sharp edges	Five yearly	Maintenance Contractor	Compare diameter to design (see Work-as-Executed) and ensure edge is not pitted or damaged.
Inspect screens and clean	Six monthly	Owner	Remove grate(s) and screens if required to clean them.
Check attachment of screens to wall of chamber or pit	Annually	Maintenance Contractor	Remove grate(s) and screen(s). Ensure screen fixings are secure. Repair as required.
Check screen(s) for corrosion	Annually	Maintenance Contractor	Remove grate(s) and examine screen(s) for rust or corrosion, especially all corners or welds.
Inspect walls (internal and external, if appropriate) for cracks or spalling	Annually	Maintenance Contractor	Remove grate(s) to inspect internal walls. Repair as required. Clear vegetation from external walls if necessary and repair as required.
Inspect outlet sumps & remove any sediment/sludge	Six monthly	Owner	Remove grate(s) and screen(s). Remove sediment/sludge build-up and check orifices are clear.
Inspect grate(s) for damage or blockage	Six monthly	Owner	Check both sides of a grate for corrosion, (especially corners and welds) damage or blockage.
Inspect outlet pipe & remove any blockage	Six monthly	Maintenance Contractor	Remove grate(s) and screen(s). Ventilate underground storage if present. Check orifices and remove any blockages in outlet pipe. Flush outlet pipe to confirm it drains freely. Check for sludge/debris on upstream side of return line.
Check step irons for corrosion	Annually	Maintenance Contractor	Remove grate. Examine step irons and repair any corrosion or damage.
Check fixing of step irons is secure	Six monthly	Maintenance Contractor	Remove grate(s) and ensure fixings are secure prior to placing weight on step iron.

MAINTENANCE ACTION	FREQUENCY	RESPONSIBILITY	PROCEDURE
Storage			
Inspect storage & remove any sediment/sludge in pit	Six monthly	Owner	Remove grate(s) and screen(s). Remove sediment/sludge build-up.
Inspect internal walls of storage (and external, if appropriate) for cracks or spalling	Annually	Maintenance Contractor	Remove grate(s) to inspect internal walls. Repair as required. Clear vegetation from external walls if necessary and repair as required.
Inspect & remove any debris/litter/mulch etc blocking grates	Six monthly	Owner	Remove blockages from grate(s) and check if storage is blocked.
Inspect areas draining to the storage(s) & remove debris/mulch/litter etc likely to block screens/grates	Six monthly	Owner	Remove debris and floatable material likely to be carried to grates.
Compare storage volume to volume approved. (Rectify if loss > 5%)	Annually	Maintenance Contractor	Compare actual storage available with Work-as Executed plans. If volume loss is greater than 5%, arrange for reconstruction to replace the volume lost. Council to be notified of the proposal.
Inspect storages for subsidence near pits	Annually	Maintenance Contractor	Check along drainage lines and at pits for subsidence likely to indicate leakages.

Frequency	Staff Needed	Time	Task
DAILY	1	10-15 minutes	<ul style="list-style-type: none"> Check for overheating Check for cavitation & bearing noise Check for motor current & voltage
WEEKLY	1	20-30 minutes	<ul style="list-style-type: none"> Check for suction & discharge pressures Check for vibration & noise Visual check for sealing and pipework leakage Check for signs of corrosion or discolouration
MONTHLY	1	20-30 minutes	<ul style="list-style-type: none"> Remove safety guards & check for shaft & auxiliary devices Check for coupling alignment Fill lubrication oil (if necessary)
ANNUALLY	2	2-3 hours	<ul style="list-style-type: none"> If you have a back up pump, run the pump & check for maintainability Check for axial movement of motor shaft Remove & clean all auxiliary devices (valves, manometers, piping's, sight glasses, etc) Remove coupling halves & check for wear at rubber part (renew if necessary)
2 YEARS OR 10000 HOURS	2	6-8 hours	<ul style="list-style-type: none"> Dismantle the pump from the piping & disassemble Make inspection on parts, replace if necessary: <ul style="list-style-type: none"> - Impellers - Wear Rings/Wear Plates - O-rings - Shaft Apply coating on un-machined surfaces

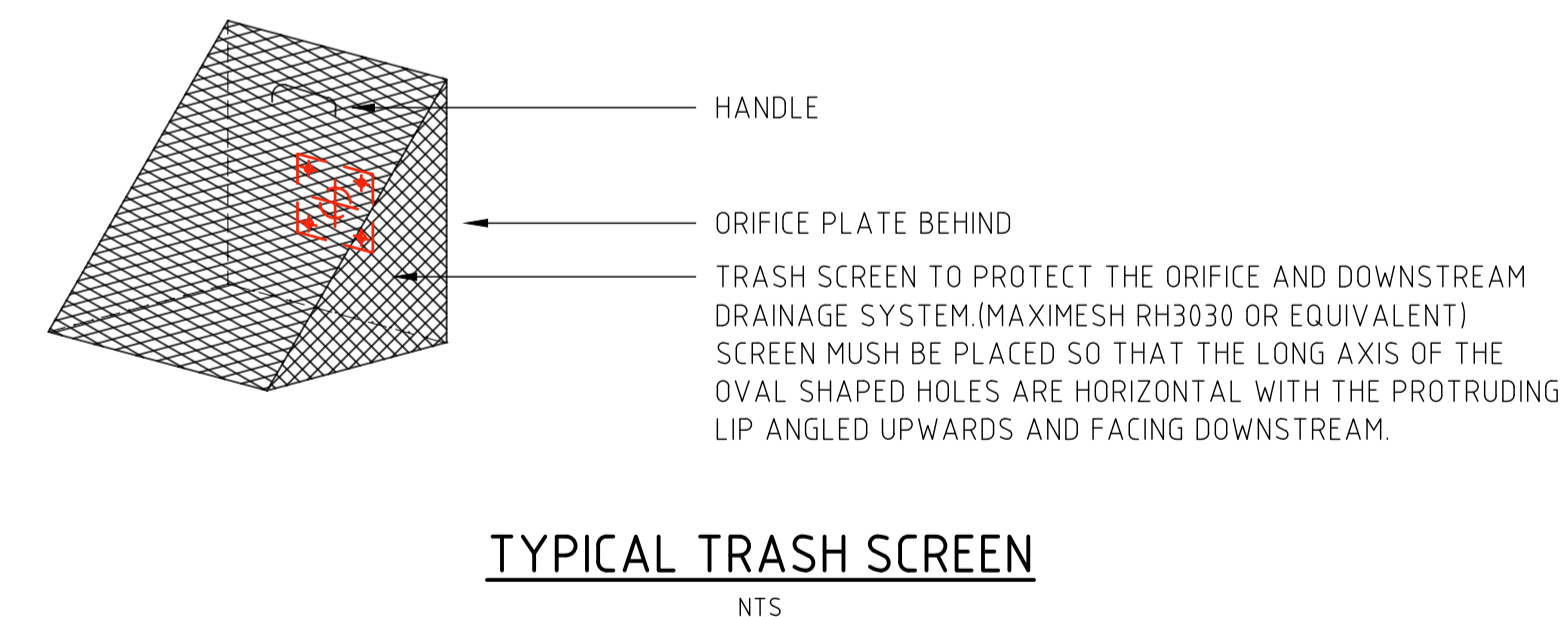
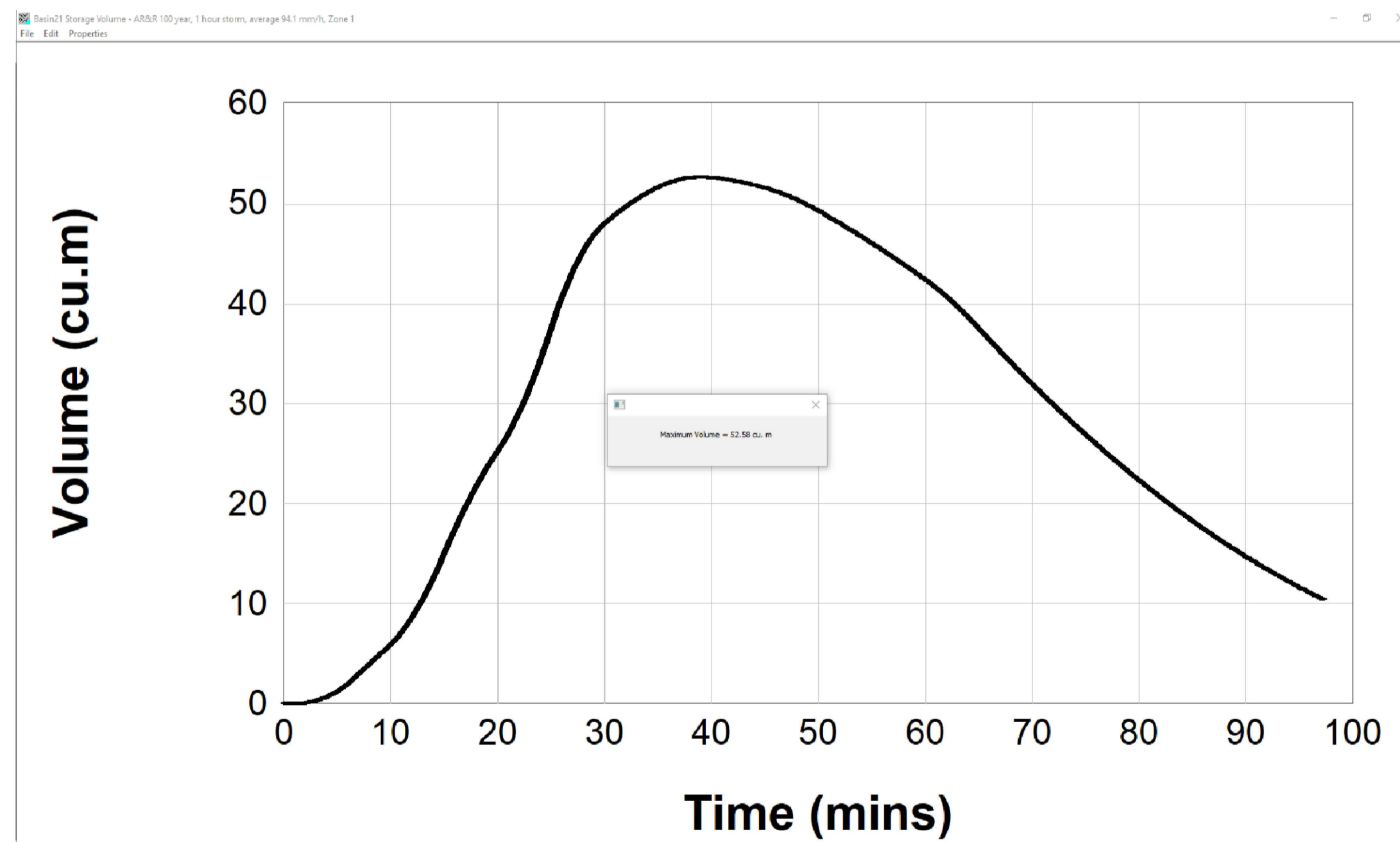

TYPICAL TRASH SCREEN
NTS

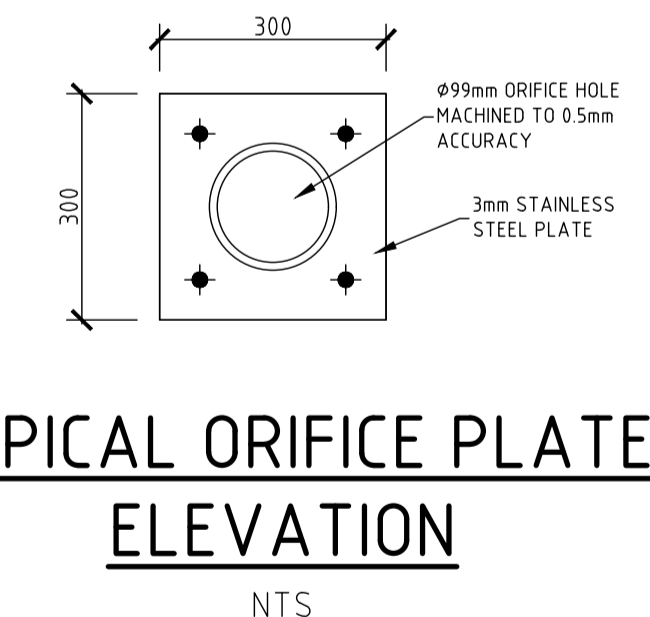

TYPICAL ORIFICE PLATE ELEVATION
NTS



REV.	DATE	BY	CHECKED	AMENDMENTS
A	01 DEC 22	M.W.	S.W.W.	PRELIMINARY ISSUE

COPYRIGHT © ALL RIGHTS RESERVED. THIS DRAWING MAY NOT BE REPRODUCED OR TRANSMITTED IN ANY FORM OR BY ANY MEANS IN PART OR IN WHOLE WITHOUT PERMISSION OF LMW DESIGN GROUP PTY. LTD.

LMW DESIGN GROUP P/L
 Building Consultants and Structural Engineers

15 Woodlands Ave.
 Lugarno NSW 2210
 Email : lmwdesigngroup@gmail.com

Phone: (02) 9533 5778
 Fax: (02) 9543 1058
 Mobile: 0418 285 592

JOB NAME
PROPOSED NEW DEVELOPMENT AT 69 MELWOOD AVE FORESTVILLE

CLIENT, ARCHITECT
ANTOINE GITTANY

DRAWING TITLE
DETAILS OF ON-SITE DETENTION TANK

No. IN SET	Job No	2096.22	DRG. No	REV
SCALE	DESIGNED	DRAWN	DATE	No.
N.T.S.	S.W.W.	M.W.	DEC.2022	

APPROVED BY

STEVEN WATERS
 B.E., M.ENG.SC.
 M.I.E. AUSTR., C.P. ENG. NPFR-3
 REG. No. 417092
 CIVIL AND STRUCTURAL

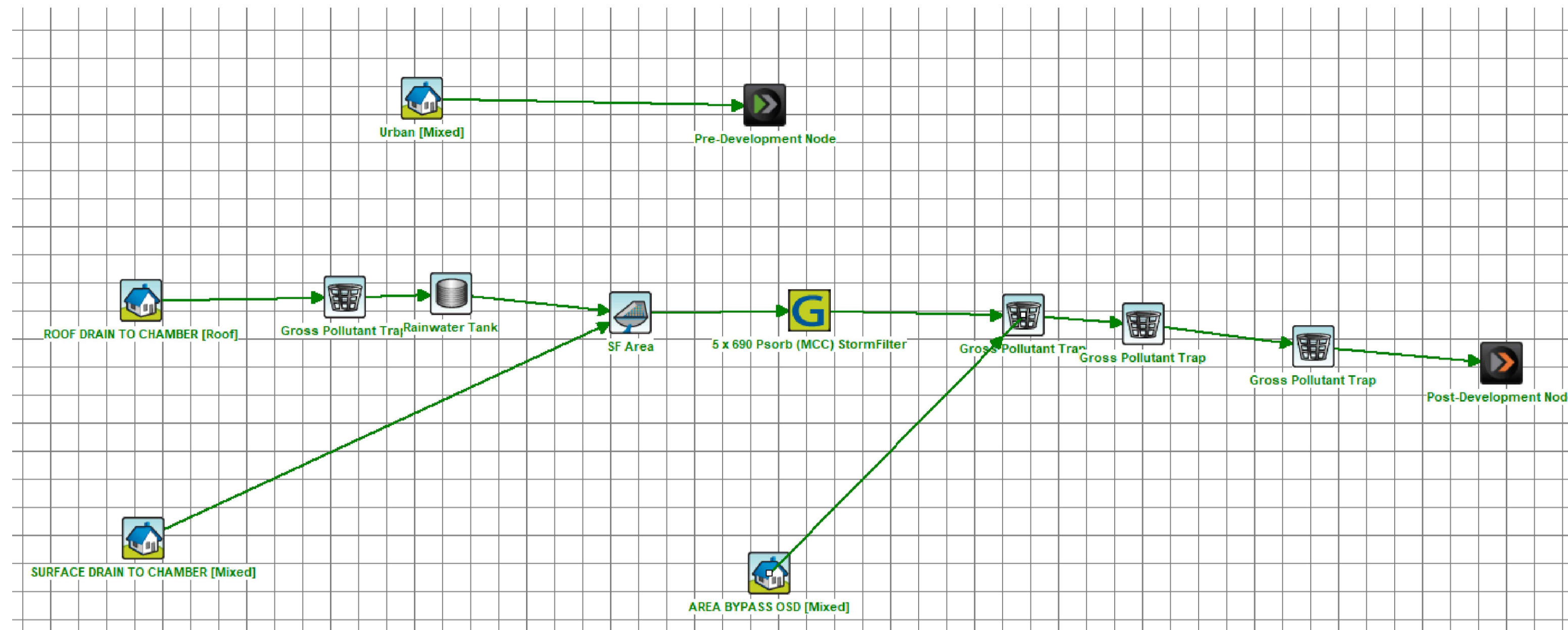

MUSIC MODELING

The Stormwater360 Maintenance Service
 To achieve a cost-effective turnkey solution for maintaining your stormwater system while also ensuring ongoing regulatory compliance. Stormwater360 has developed a systematic maintenance approach to inspecting, cleaning and repairing different types of stormwater systems. We utilise fully trained experts who are familiar with the characteristics of each type of system, and the processes required to optimise its efficiency and performance. Regular maintenance of these devices includes inspection, recording and reporting, and is accompanied by periodic cleaning to remove accumulated debris and ensure optimal performance. Depending on the size of the system, it may be cleaned from the surface by hand, or may need to be accessed via a manhole and the debris removed using a large vacuum hose attached to an inductor truck.

Online maintenance tracker
 With many local authorities implementing complex and onerous stormwater regulations and water quality standards, compliance is an increasingly important issue for asset owners. The Stormwater360 Maintenance Service designs a sitespecific maintenance plan for each facility and through proper documentation and reporting provides evidence that all relevant procedures have been adhered to. In addition, Stormwater360 offers the unique service of online tracking for your maintenance and reporting, which enables you to access up-to-date images and reports of your system's maintenance.

ABBREVIATIONS

- AH----ACCESS HATCH
- DDO---DISH DRAIN OUTLET
- CO----CLEAR OUT
- DCP----DISCHARGE CONTROL PIT
- DP-----DOWNPIPE
- FFL----FINISH FLOOR LEVEL
- FW-----FLOOR WASTE
- GL-----GROUND FLOOR LEVEL
- IL-----INVERT LEVEL
- OSD----ON SITE DETENTION
- PD-----PLANTERS DRAIN
- PFO----PLANTER FLOOR OUTLET
- PP-----PLANTER PIT
- RH----RAINWATER HEAD
- RP-----RELN PIT
- RO-----ROOF OUTLET
- SDO---STRIP DRAIN OUTLET
- SIP----SURFACE INLET PIT
- STP----SILT TRAP PIT
- SP-----SPREADER
- TD-----TUN DISH

Table 5 – General Stormwater Quality Requirements

Pollutant	Performance Requirements
Total Phosphorous	65% reduction in the post development mean annual load ¹
Total Nitrogen	45% reduction in the post development mean annual load ¹
Total Suspended Solids	85% reduction in the post development mean annual load ¹
Gross Pollutants	90% reduction in the post development mean annual load ¹ (for pollutants greater than 5mm in diameter)
pH	6.5 - 8.5
Hydrology	The post-development peak discharge must not exceed the pre-development peak discharge for flows up to the 50% AEP

¹The percentage reduction in the post development mean annual loads are relative to the loads from the proposed development without treatment applied.

MUSIC REQUIREMENT

	Sources		Residual Load		% Reduction	
	Pre	Post	Pre	Post	Pre	Post
Flow (ML/yr)	0.463	0.826	0.463	0.826	0	0
Total Suspended Solids (kg/yr)	87.2	63.2	87.2	7.08	0	88.8
Total Phosphorus (kg/yr)	0.136	0.166	0.136	0.0284	0	82.9
Total Nitrogen (kg/yr)	1.02	1.81	1.02	0.811	0	55.2
Gross Pollutants (kg/yr)	14.1	22.9	14.1	0	0	100

Include Pre-Development

MUSIC RESULT



REV.	DATE	BY	CHECKED	AMENDMENTS
A	29 MAY 23	M.W.	S.W.W.	PRELIMINARY ISSUE

COPYRIGHT © ALL RIGHTS RESERVED. THIS DRAWING MAY NOT BE REPRODUCED OR TRANSMITTED IN ANY FORM OR BY ANY MEANS IN PART OR IN WHOLE WITHOUT PERMISSION OF LMW DESIGN GROUP PTY. LTD.

LMW DESIGN GROUP P/L
 Building Consultants and Structural Engineers

15 Woodlands Ave.
 Lugarno NSW 2210

Phone: (02) 9533 5778
 Fax: (02) 9543 1058
 Mobile: 0418 285 592
 Email: lmwdesigngroup@gmail.com

JOB NAME
**PROPOSED NEW DEVELOPMENT AT
 69 MELWOOD AVE
 FORESTVILLE**

CLIENT, ARCHITECT
ANTOINE GITTANY

DRAWING TITLE
DETAILS OF MUSIC MODELING

No. IN SET	JOB No	2096.22	DRG. No	REV
SCALE	DESIGNED	DRAWN	DATE	No.
N.T.S.	S.W.W.	M.W.	MAY.2023	

APPROVED BY **STEVEN WATERS**
 B.E., M.Eng.Sc.
 M.I.E. Aust., C.P. Eng, NPER-3
 REG. No. 417092
 CIVIL AND STRUCTURAL

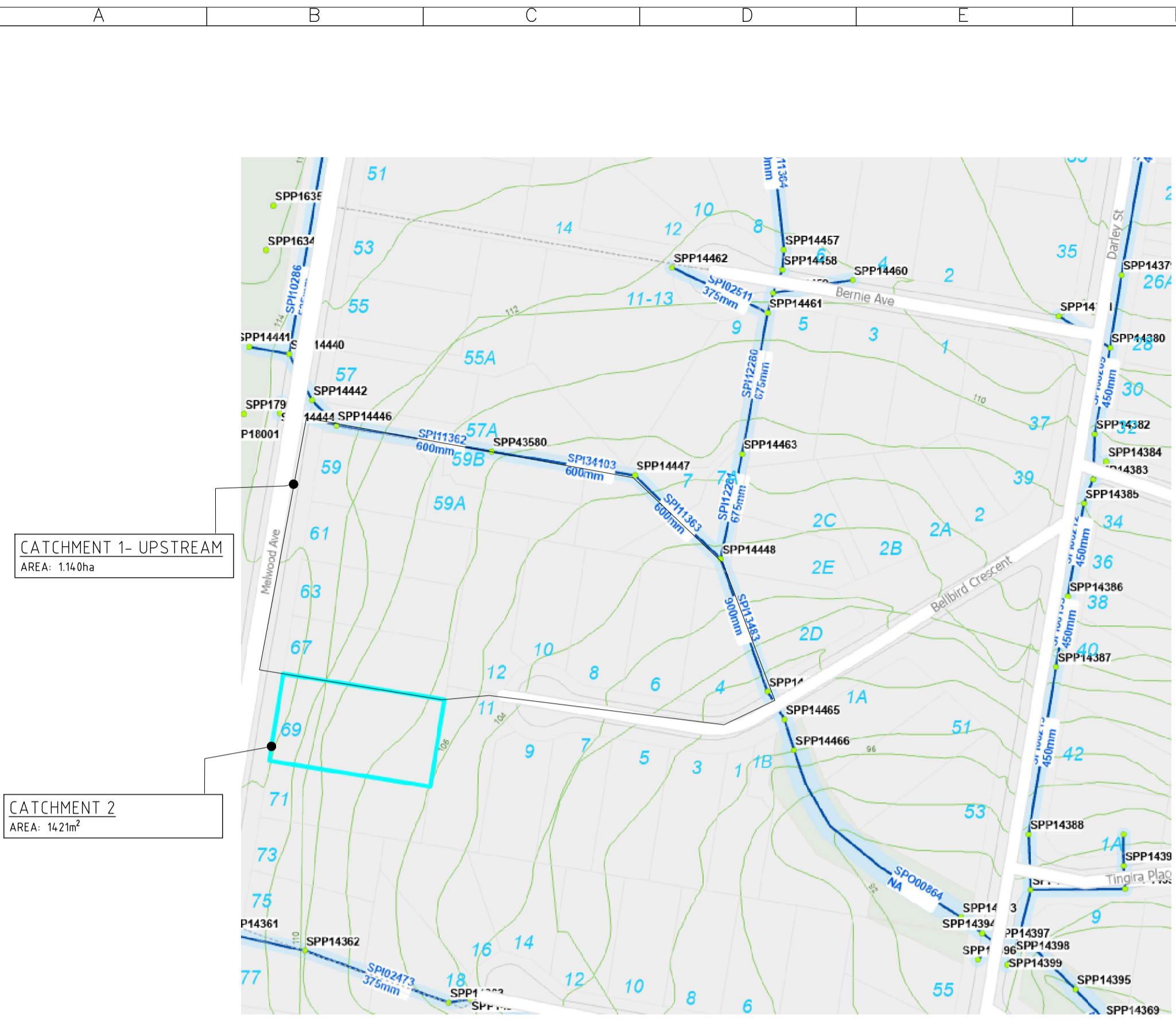

CATCHMENT AREA FOR GUTTER CAPACITY ANALYSIS

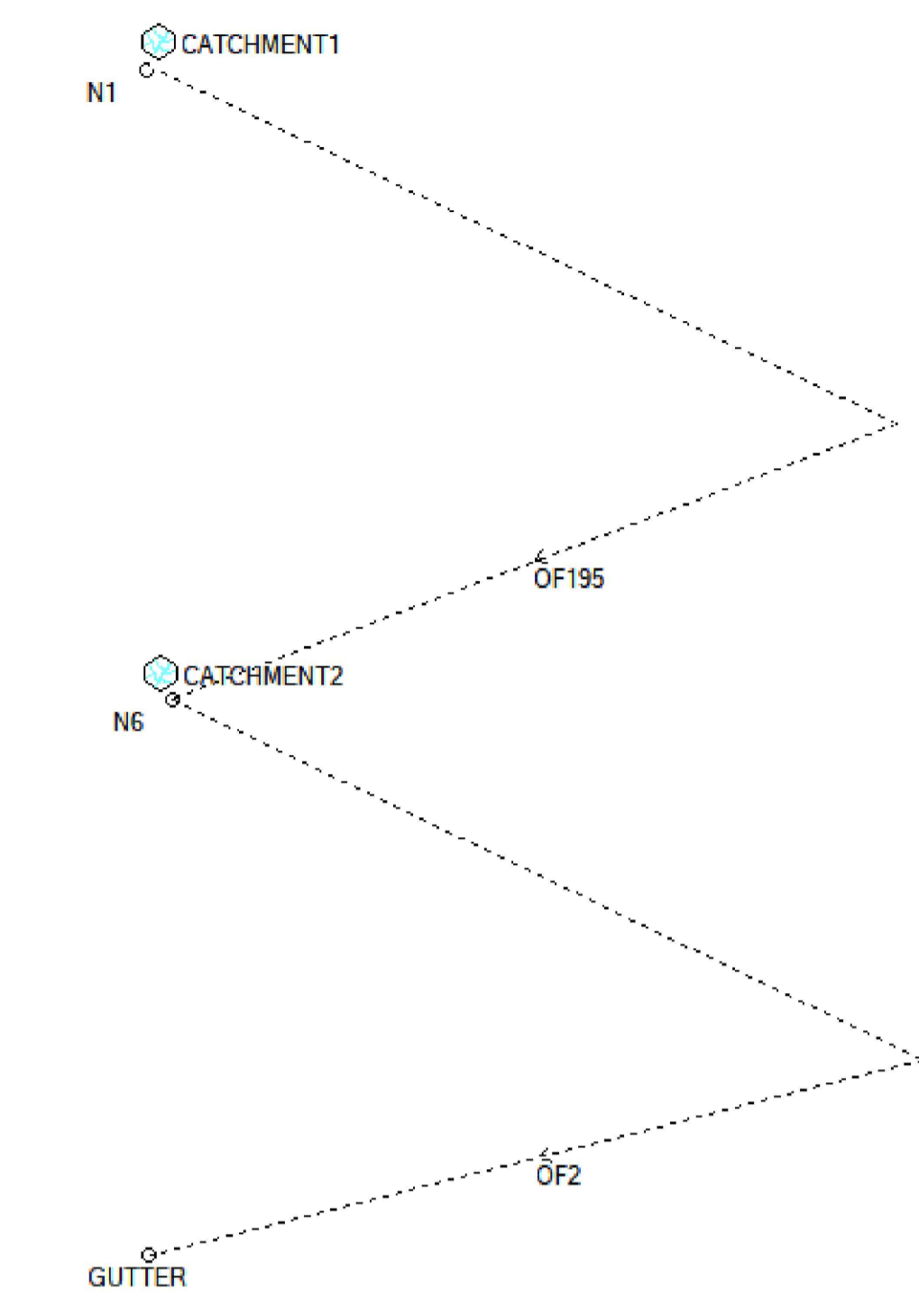

CATCHMENT AREA DRAINS MODEL

RESULTS OF CATCHMENT ANALYSIS

- TOTAL CATCHMENT AREA: 1.140 ha
- ASSUMING IMPERVIOUS AREA RATIO: 50%
- THE OUTFLOW OF THE WHOLE CATCHMENT: 630L/s

THE TOTAL FLOW RATE OF LOCAL CATCHMENT IN 100 YEAR ARI STORM EVENT IS 630L/S. THE DISCHARGE OF PROPOSED DEVELOPMENT IS 36L/s, 5.7% OF THE TOTAL CATCHMENT DISCHARGE, WHICH HAS MINOR EFFECT ON THE LOCAL CATCHMENT AND EXISTING GUTTERS AND PIPES.

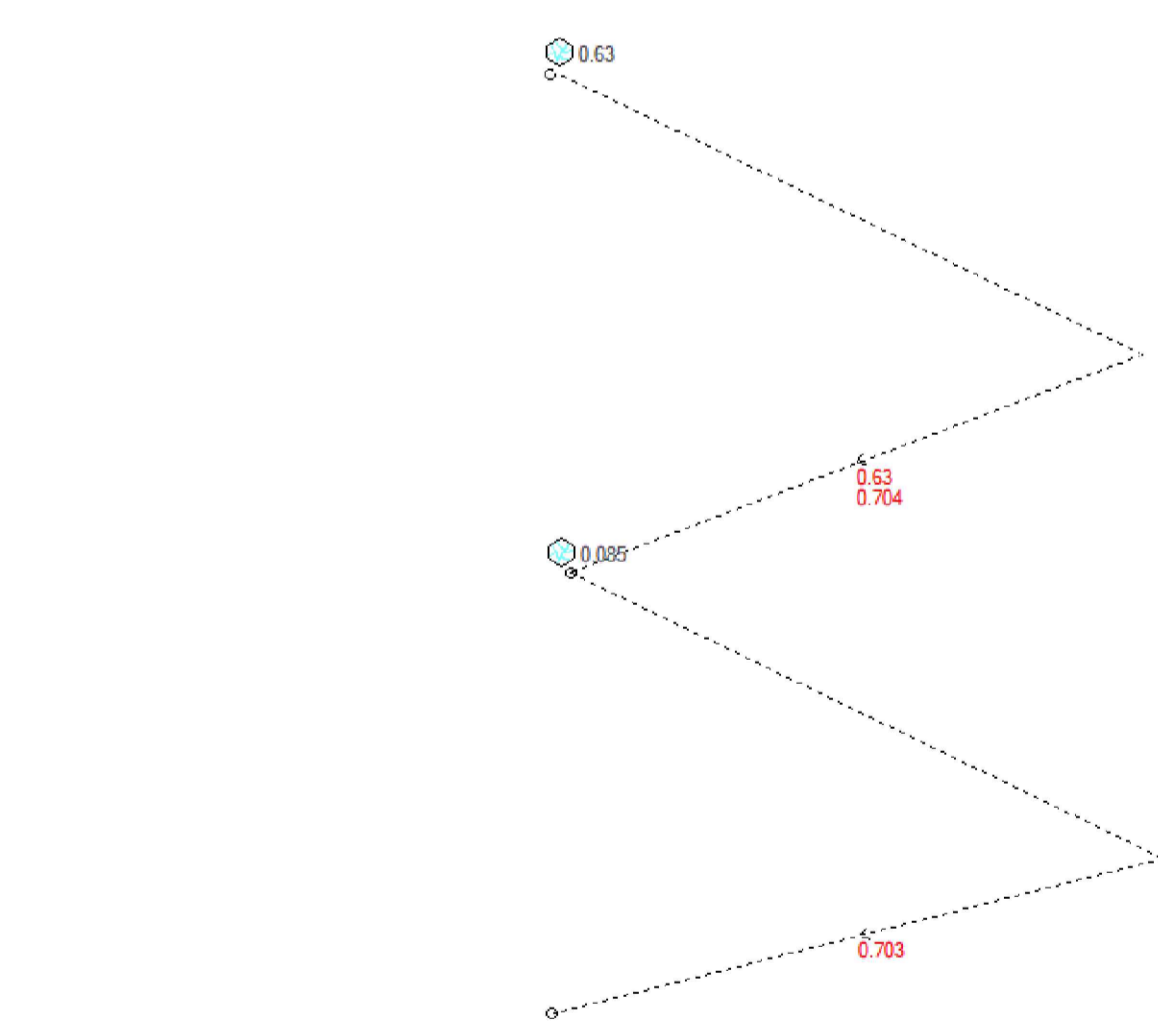

DRAINS RESULTS

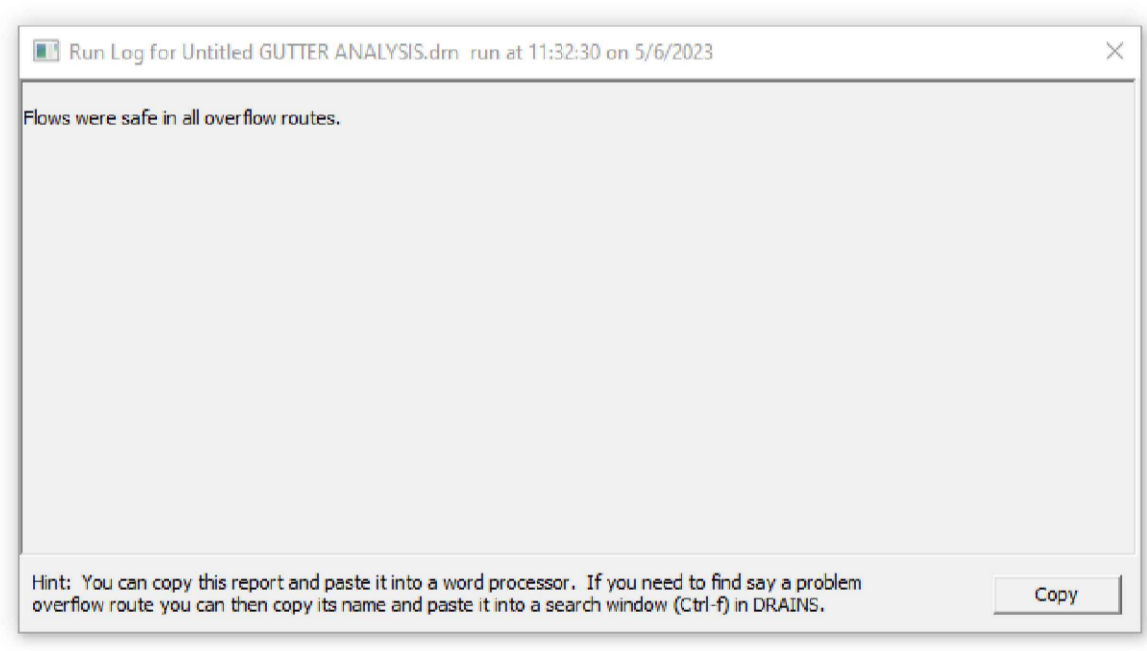

RESULTS FOR OVERFLOW 1

RESULTS FOR OVERFLOW 2

REV.	DATE	BY	CHECKED	AMENDMENTS
A	05 JUN 23	M.W.	S.W.W.	PRELIMINARY ISSUE

COPYRIGHT © ALL RIGHTS RESERVED, THIS DRAWING MAY NOT BE REPRODUCED OR TRANSMITTED IN ANY FORM OR BY ANY MEANS IN PART OR IN WHOLE WITHOUT PERMISSION OF LMW DESIGN GROUP PTY. LTD.

LMW DESIGN GROUP P/L
Building Consultants and Structural Engineers

15 Woodlands Ave.
Lugarno NSW 2210

Phone: (02) 9533 5778
Fax: (02) 9543 1058
Mobile: 0418 285 592
Email: lmwdesigngroup@gmail.com

JOB NAME
**PROPOSED NEW DEVELOPMENT AT
69 MELWOOD AVE
FORESTVILLE**

CLIENT, ARCHITECT
ANTONIO GITTANY

DRAWING TITLE
GUTTER FLOW ANALYSIS

No. IN SET	JOB No	2096.22	DRG. No	REV
			D3B	A
SCALE	DESIGNED	DRAWN	DATE	No.
N.T.S.	S.W.W.	M.W.	MAY 2023	

APPROVED BY  **STEVEN WATERS**
B.E., M.ENG.SC.
M.I.E. AUSTR., C.P. ENG., NPFR-3
REG. No. 417092
CIVIL AND STRUCTURAL



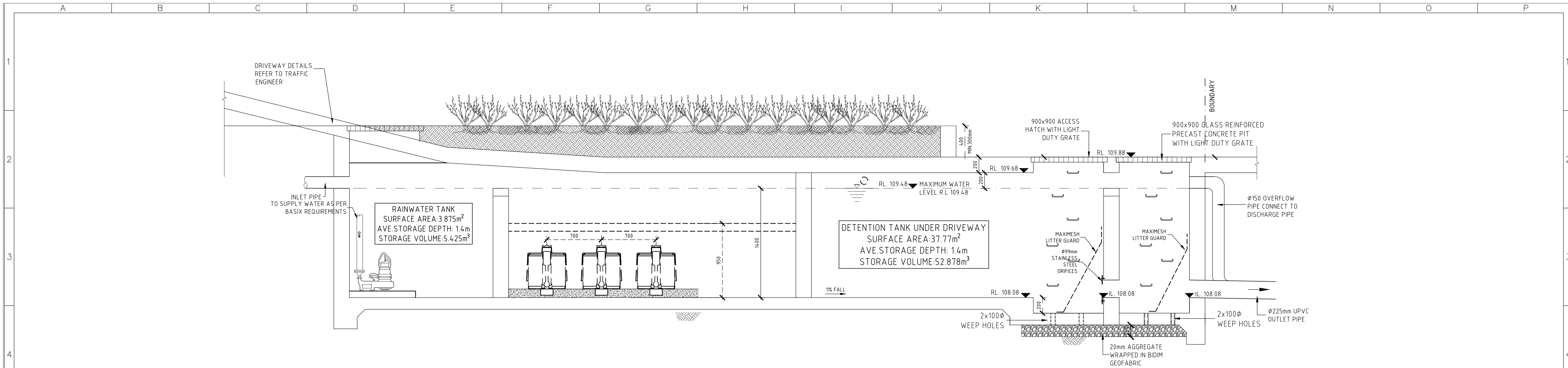

SECTION A OSD TANK DETAILS
SCALE: 1:25

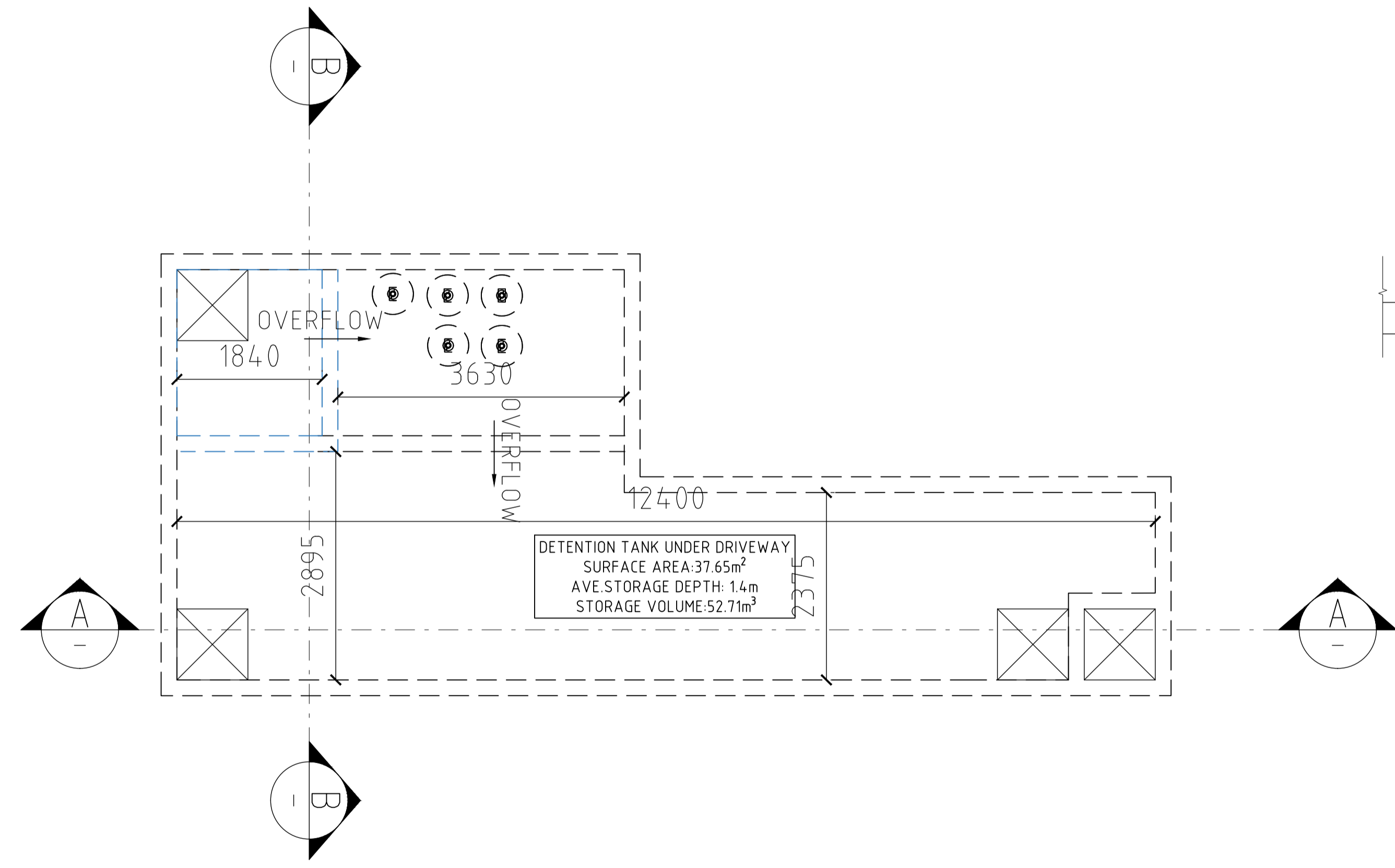

SECTION B OSD TANK DETAILS
SCALE: 1:25

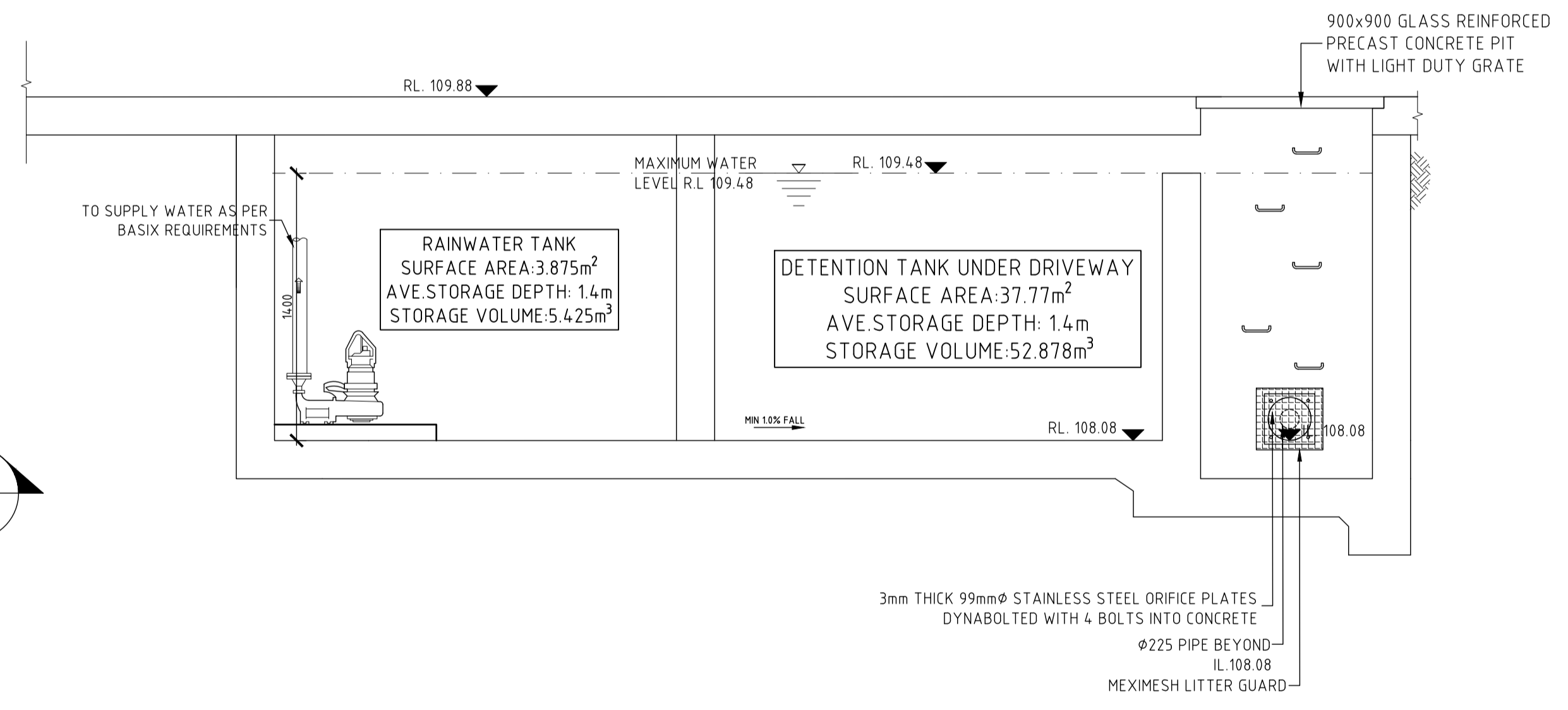

REV.	DATE	BY	CHECKED	AMENDMENTS
C	23 JUN 23	S.C.	S.W.W.	REVISED PLAN
B	29 MAY 23	M.W.	S.W.W.	UPDATED DRAWING
A	01 DEC 22	S.C.	S.W.W.	PRELIMINARY ISSUE

COPYRIGHT © ALL RIGHTS RESERVED. THIS DRAWING MAY NOT BE REPRODUCED OR TRANSMITTED IN ANY FORM OR BY ANY MEANS IN PART OR IN WHOLE WITHOUT PERMISSION OF LMW DESIGN GROUP PTY. LTD.

LMW DESIGN GROUP P/L
Building Consultants and Structural Engineers

15 Woodlands Ave.
Lugarno NSW 2210

Phone: (02) 9533 5778
Fax: (02) 9543 1058
Mobile: 0418 285 592
Email: lmwdesigngroup@gmail.com

JOB NAME
**PROPOSED NEW DEVELOPMENT AT
69 MELWOOD AVE
FORESTVILLE**

CLIENT, ARCHITECT
ANTOINE GITTANY

DRAWING TITLE
OSD SECTION DETAILS

No. IN SET	JOB No	2096.22	DRG. No	REV
SCALE	DESIGNED	DRAWN	DATE	No.
N.T.S.	S.W.W.	M.W.	DEC.2022	

APPROVED BY  **STEVEN WATERS**
B.E., M.Eng.Sc.
M.I.E. AUSTR., C.P. Eng, NPER-3
REG. No. 417092
CIVIL AND STRUCTURAL



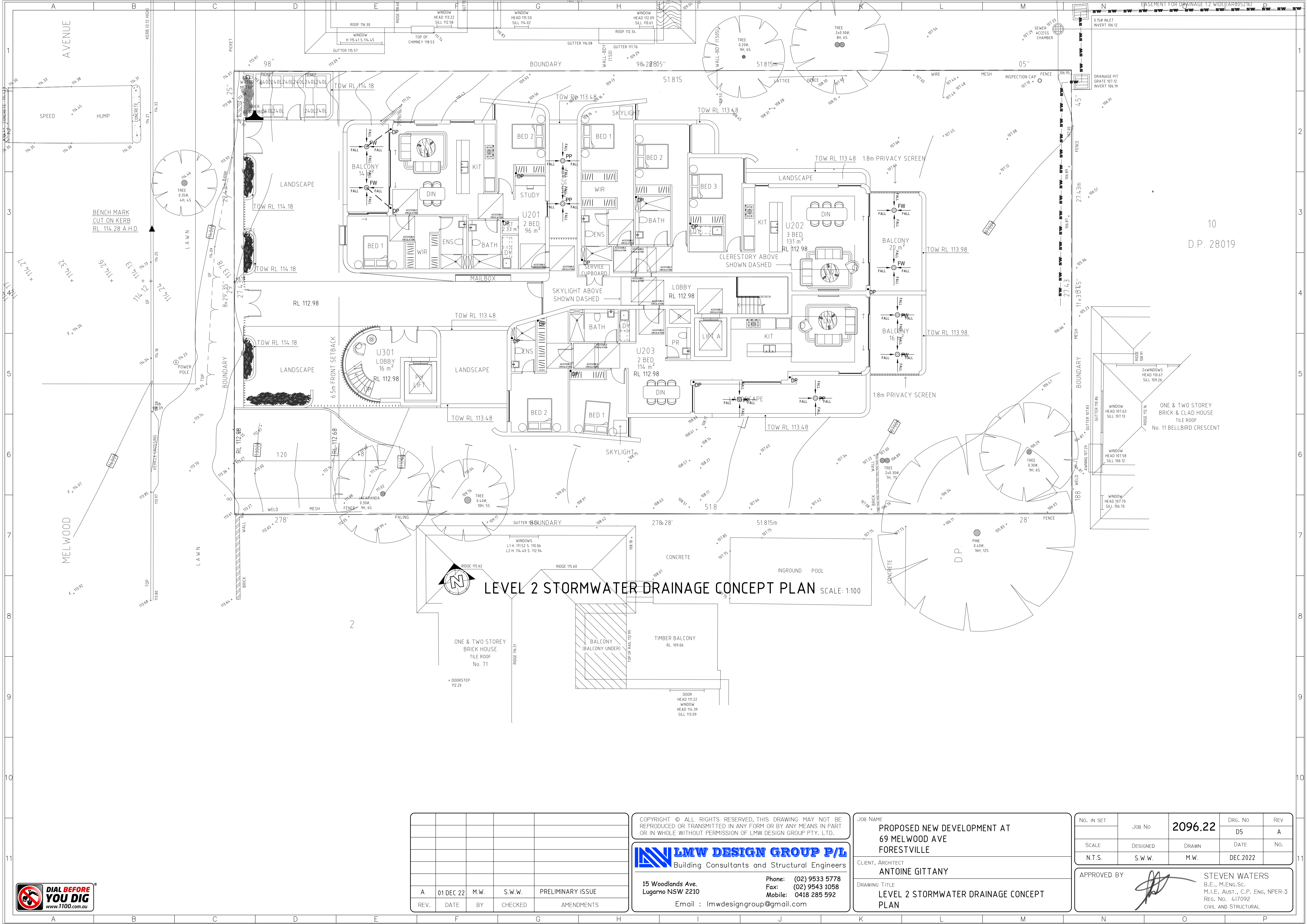

LEVEL 2 STORMWATER DRAINAGE CONCEPT PLAN SCALE: 1:100

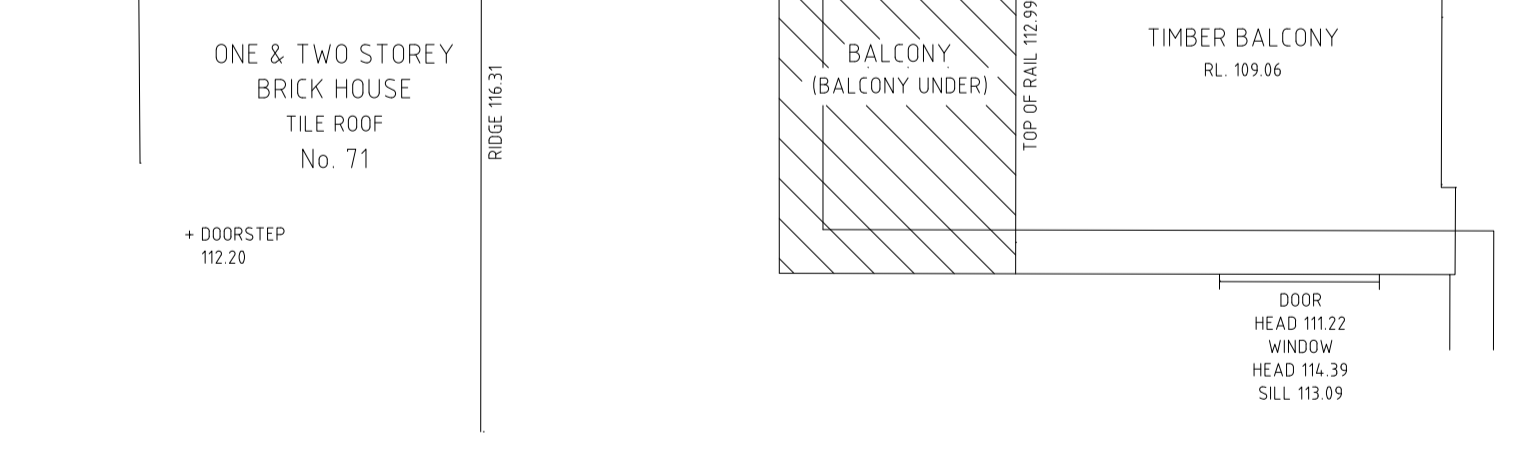
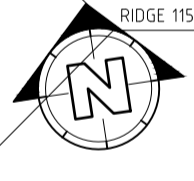

REV.	DATE	BY	CHECKED	AMENDMENTS
A	01 DEC 22	M.W.	S.W.W.	PRELIMINARY ISSUE

COPYRIGHT © ALL RIGHTS RESERVED. THIS DRAWING MAY NOT BE REPRODUCED OR TRANSMITTED IN ANY FORM OR BY ANY MEANS IN PART OR IN WHOLE WITHOUT PERMISSION OF LMW DESIGN GROUP PTY. LTD.

LMW DESIGN GROUP P/L
Building Consultants and Structural Engineers

15 Woodlands Ave.
Lugarno NSW 2210
Phone: (02) 9533 5778
Fax: (02) 9543 1058
Mobile: 0418 285 592
Email: lmwdesigngroup@gmail.com

JOB NAME
**PROPOSED NEW DEVELOPMENT AT
69 MELWOOD AVE
FORESTVILLE**

CLIENT, ARCHITECT
ANTOINE GITTANY

DRAWING TITLE
**LEVEL 2 STORMWATER DRAINAGE CONCEPT
PLAN**

No. in SET	Job No	2096.22	DRG. No	REV
SCALE	DESIGNED	DRAWN	DATE	No.
N.T.S.	S.W.W.	M.W.	DEC.2022	

APPROVED BY  **STEVEN WATERS**
B.E., M.Eng.Sc.
M.I.E. AUSTR., C.P. Eng, NPER-3
REG. No. 417092
CIVIL AND STRUCTURAL



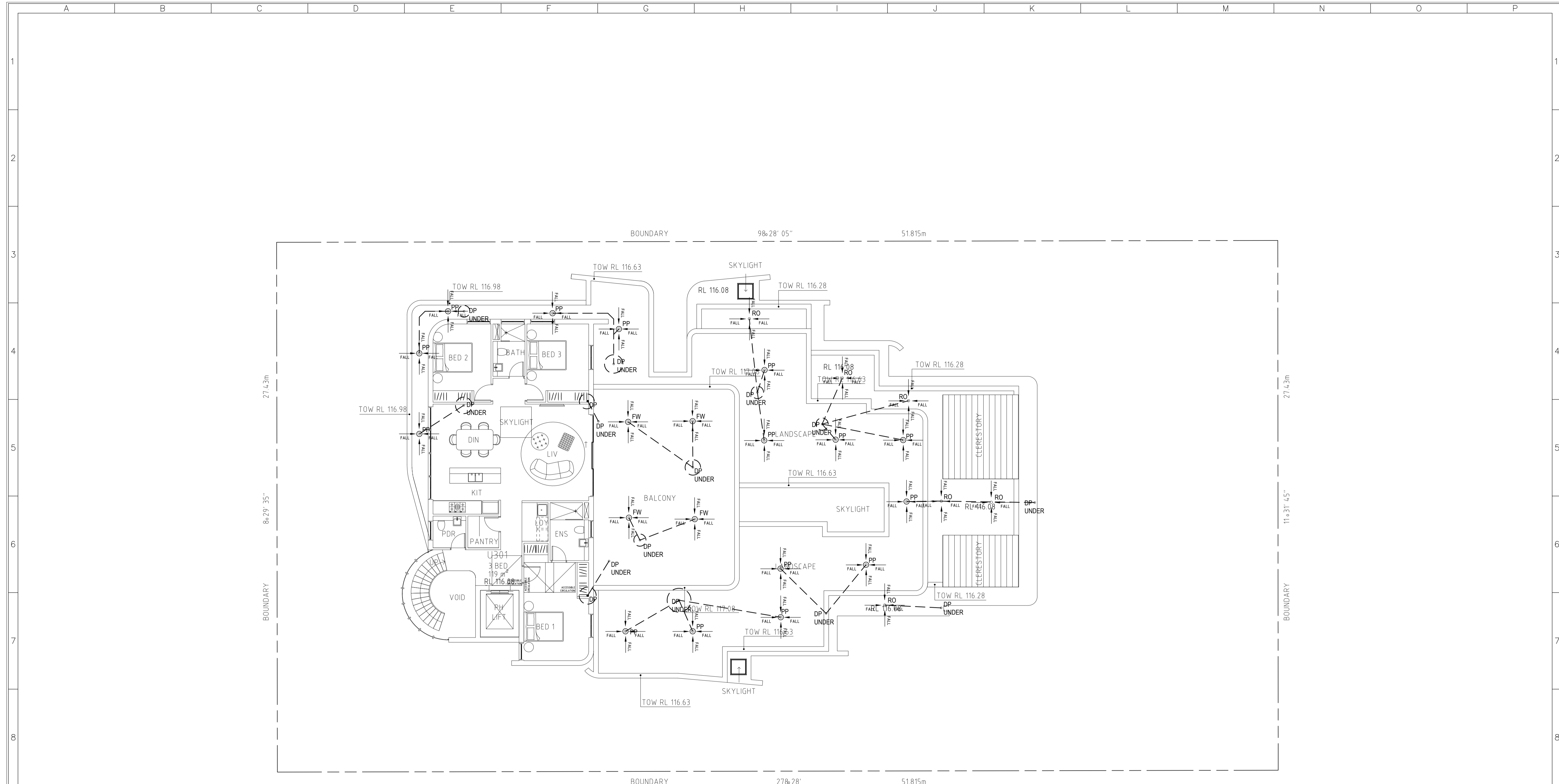

LEVEL 3 STORMWATER DRAINAGE CONCEPT PLAN SCALE: 1:100

REV.	DATE	BY	CHECKED	AMENDMENTS
A	01 DEC 22	M.W.	S.W.W.	PRELIMINARY ISSUE

COPYRIGHT © ALL RIGHTS RESERVED, THIS DRAWING MAY NOT BE REPRODUCED OR TRANSMITTED IN ANY FORM OR BY ANY MEANS IN PART OR IN WHOLE WITHOUT PERMISSION OF LMW DESIGN GROUP PTY. LTD.

LMW DESIGN GROUP P/L
Building Consultants and Structural Engineers

15 Woodlands Ave.
Lugarno NSW 2210

Phone: (02) 9533 5778
Fax: (02) 9543 1058
Mobile: 0418 285 592
Email: lmwdesigngroup@gmail.com

JOB NAME
**PROPOSED NEW DEVELOPMENT AT
69 MELWOOD AVE
FORESTVILLE**

CLIENT, ARCHITECT
ANTOINE GITTANY

DRAWING TITLE
**LEVEL 3 STORMWATER DRAINAGE CONCEPT
PLAN**

No. IN SET	Job No	2096.22	Drwg. No	REV
SCALE	DESIGNED	DRAWN	DATE	No.
N.T.S.	S.W.W.	M.W.	DEC.2022	

APPROVED BY  **STEVEN WATERS**
B.E., M.Eng.Sc.
M.I.E. (AUST.), C.P. Eng., NPER-3
REG. No. 417092
CIVIL AND STRUCTURAL



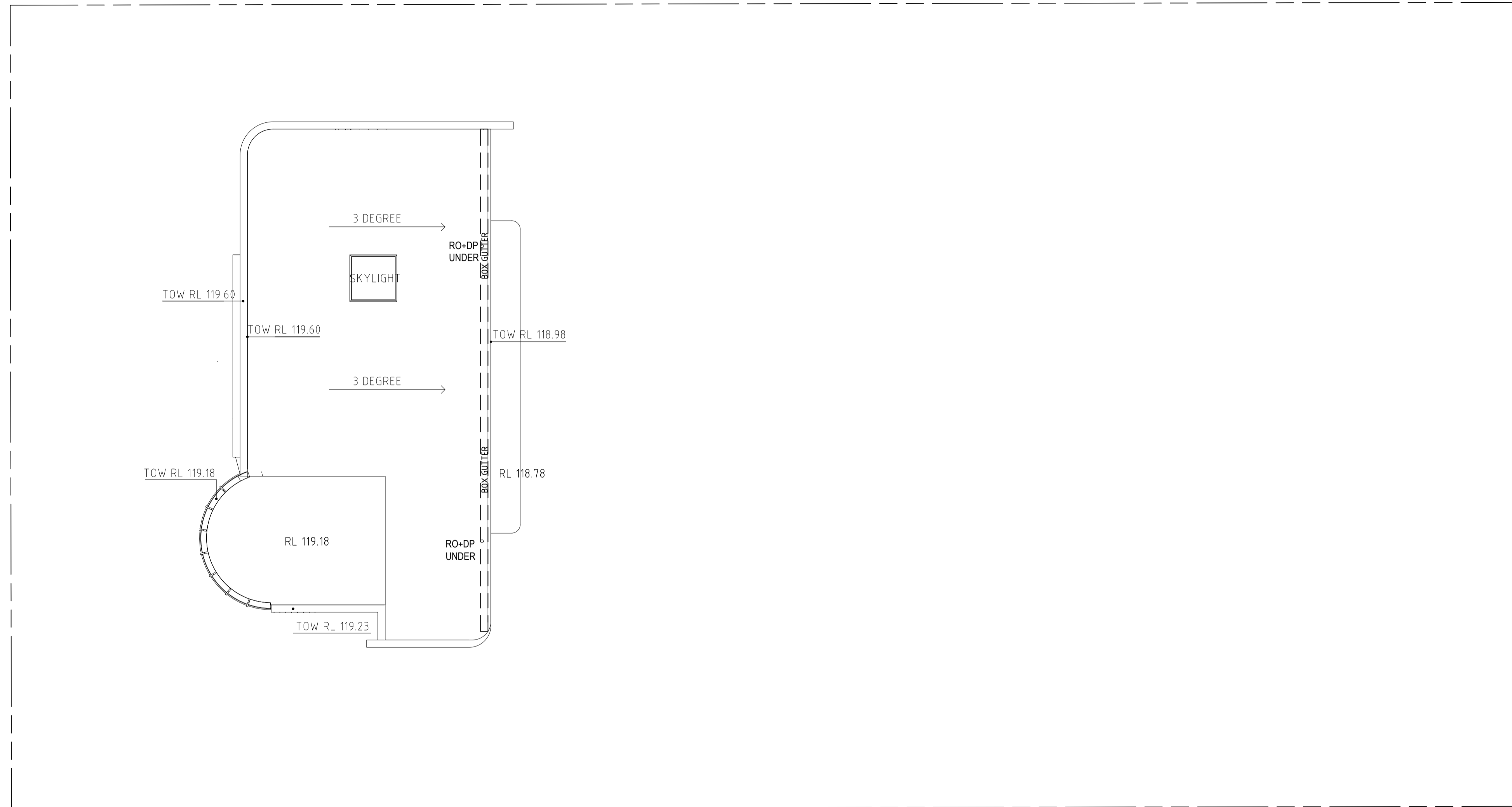

ROOF STORMWATER DRAINAGE CONCEPT PLAN SCALE: 1:100

REV.	DATE	BY	CHECKED	AMENDMENTS
A	01 DEC 22	M.W.	S.W.W.	PRELIMINARY ISSUE

COPYRIGHT © ALL RIGHTS RESERVED, THIS DRAWING MAY NOT BE REPRODUCED OR TRANSMITTED IN ANY FORM OR BY ANY MEANS IN PART OR IN WHOLE WITHOUT PERMISSION OF LMW DESIGN GROUP PTY. LTD.

LMW DESIGN GROUP P/L
Building Consultants and Structural Engineers

15 Woodlands Ave.
Lugarno NSW 2210
Email : lmwdesigngroup@gmail.com

Phone: (02) 9533 5778
Fax: (02) 9543 1058
Mobile: 0418 285 592

JOB NAME
**PROPOSED NEW DEVELOPMENT AT
69 MELWOOD AVE
FORESTVILLE**

CLIENT, ARCHITECT
ANTOINE GITTANY

DRAWING TITLE
ROOF STORMWATER DRAINAGE CONCEPT PLAN

No. IN SET	Job No	2096.22	DRG. No	REV
			D7	A
SCALE	DESIGNED	DRAWN	DATE	No.
N.T.S.	S.W.W.	M.W.	DEC.2022	

APPROVED BY  **STEVEN WATERS**
B.E., M.ENG.SC.
M.I.E. AUST., C.P. ENG, NPER-3
REG. No. 417092
CIVIL AND STRUCTURAL

