

STORMWATER SUB-SOIL PUMP STATION 5m<sup>2</sup>  
NOT TO SCALE

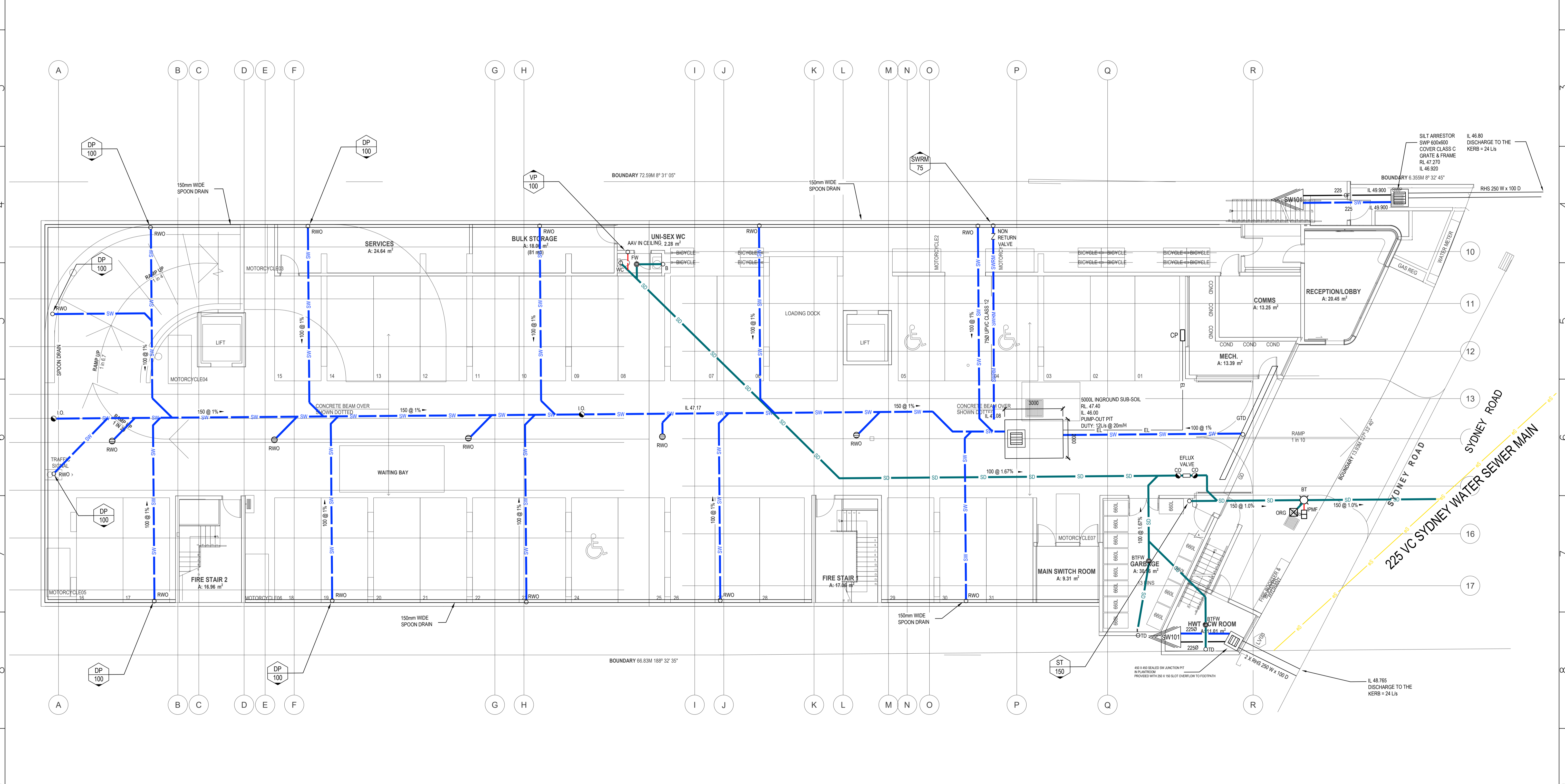

AMENDMENTS/REVISIONS				AMENDMENTS/REVISIONS			
Rev	Description	Initials	Date	Rev	Description	Initials	Date
01	PRELIMINARY ISSUE		07.12.20				
02	TENDER ISSUE	BM	14.12.20				
03	TENDER ISSUE	BM	05.02.21				

CLIENT

ARCHITECT

**MOSTAGHIM**

a 12, 17 federation rd, newtown nsw 2042  
 w mostaghim.com.au  
 e info@mostaghim.com.au  
 p 02 9557 2002

CONSULTANT

**IGS** INTEGRATED GROUP SERVICES

Phone +61 2 8488 4600 Fax +61 2 9475 4588  
 Address Suite 1.11, 75 Mary St, St Peters, NSW 2044 Australia  
 Web www.igs.com.au

PROJECT

195-197 SYDNEY ROAD  
 FAIRLIGHT

DRAWING TITLE

HYDRAULIC SERVICES  
 GROUND FLOOR  
 DRAINAGE

TENDER ISSUE					
DRAWN	DESIGNED	CHECKED	SCALE (AT FULL SIZE)	DATE	REVISION
RH	GM	MC	1:100 @ A1	FEB 21	
PROJECT No. EN-N18_89			DRAWING No. H100		03

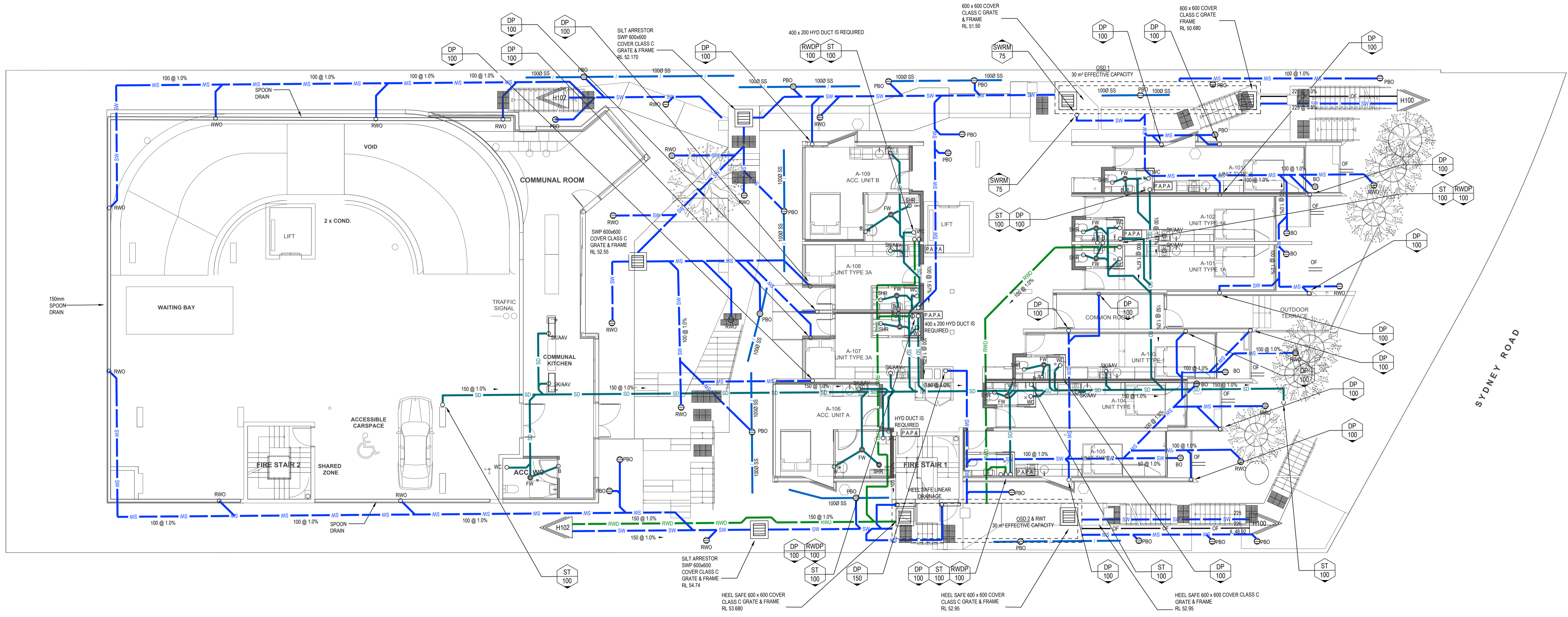
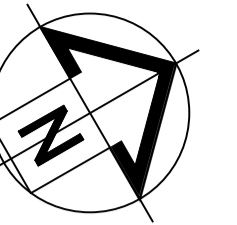
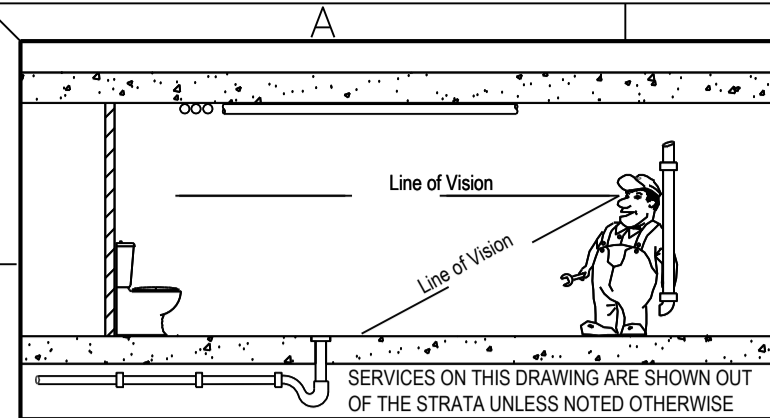

AMENDMENTS/REVISIONS			
Rev	Description	Initials	Date
01	PRELIMINARY ISSUE	BM	07.12.20
02	TENDER ISSUE	BM	15.12.20
03	TENDER ISSUE	RH	21.12.20
04	TENDER ISSUE	RH	22.12.20
05	TENDER ISSUE	RH	04.02.21

AMENDMENTS/REVISIONS			
Rev	Description	Initials	Date

CLIENT

ARCHITECT

**MOSTAGHIM**

a L2, 17 federation rd, Newtown NSW 2042  
 w mostaghim.com.au  
 e info@mostaghim.com.au  
 p 02 9557 2002

CONSULTANT

IGS INTEGRATED GROUP SERVICES

Phone +61 2 8488 4600 Fax +61 2 9475 4588  
 Address Suite 1.11, 75 Mary St, St Peters, NSW 2044 Australia  
 www.igs.com.au

PROJECT

195-197 SYDNEY ROAD  
 FAIRLIGHT

DRAWING TITLE

HYDRAULIC SERVICES  
 LEVEL 1  
 DRAINAGE

TENDER ISSUE					
DRAWN	DESIGNED	CHECKED	SCALE (AT FULL SIZE)	DATE	
RH	GM	MC	1:100 @ A1	FEB 21	
PROJECT No.			DRAWING No.	REVISION	
EN-N18_89			H101	05	

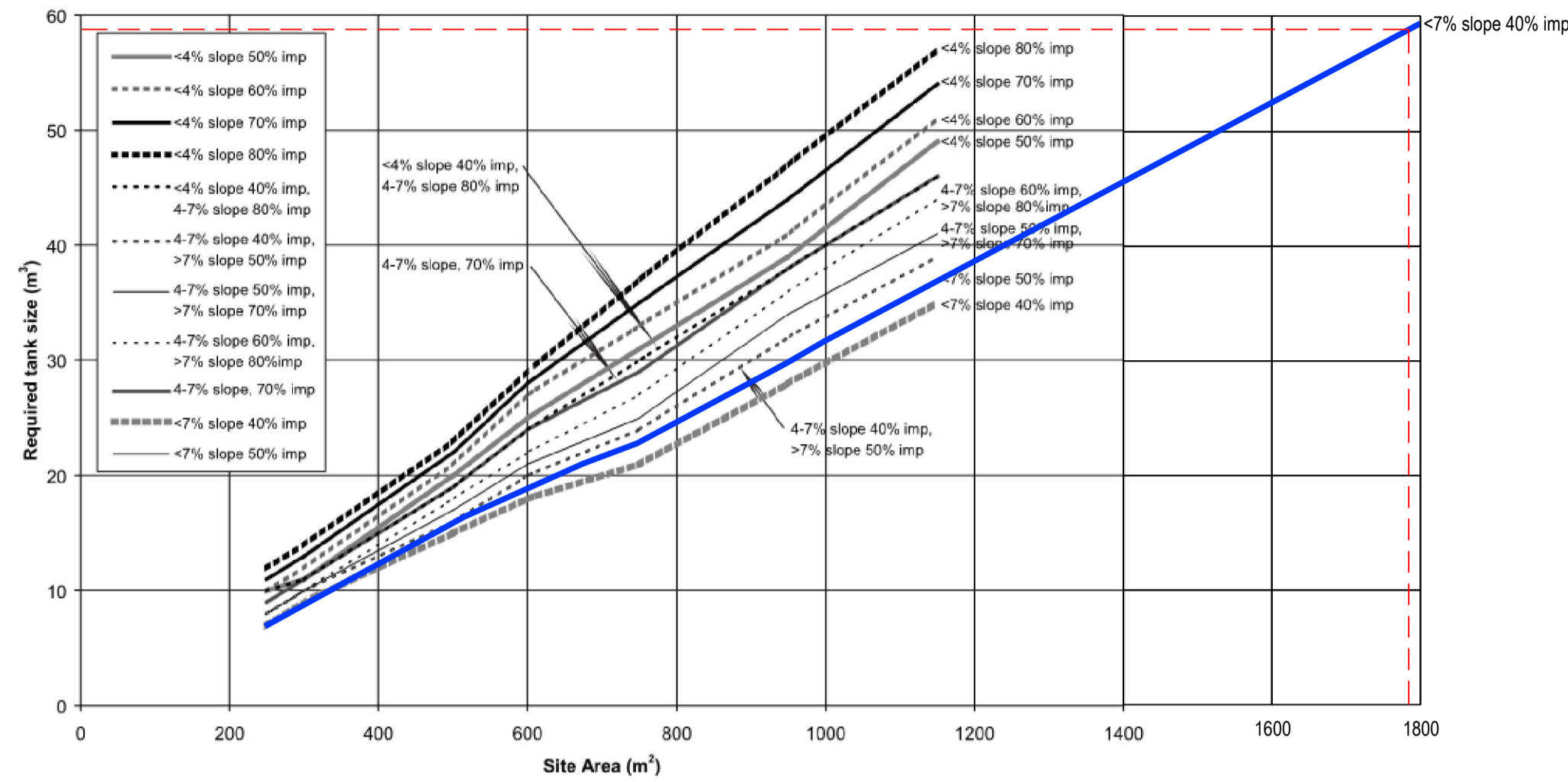

Density subzone 3-6—35% predeveloped impervious area

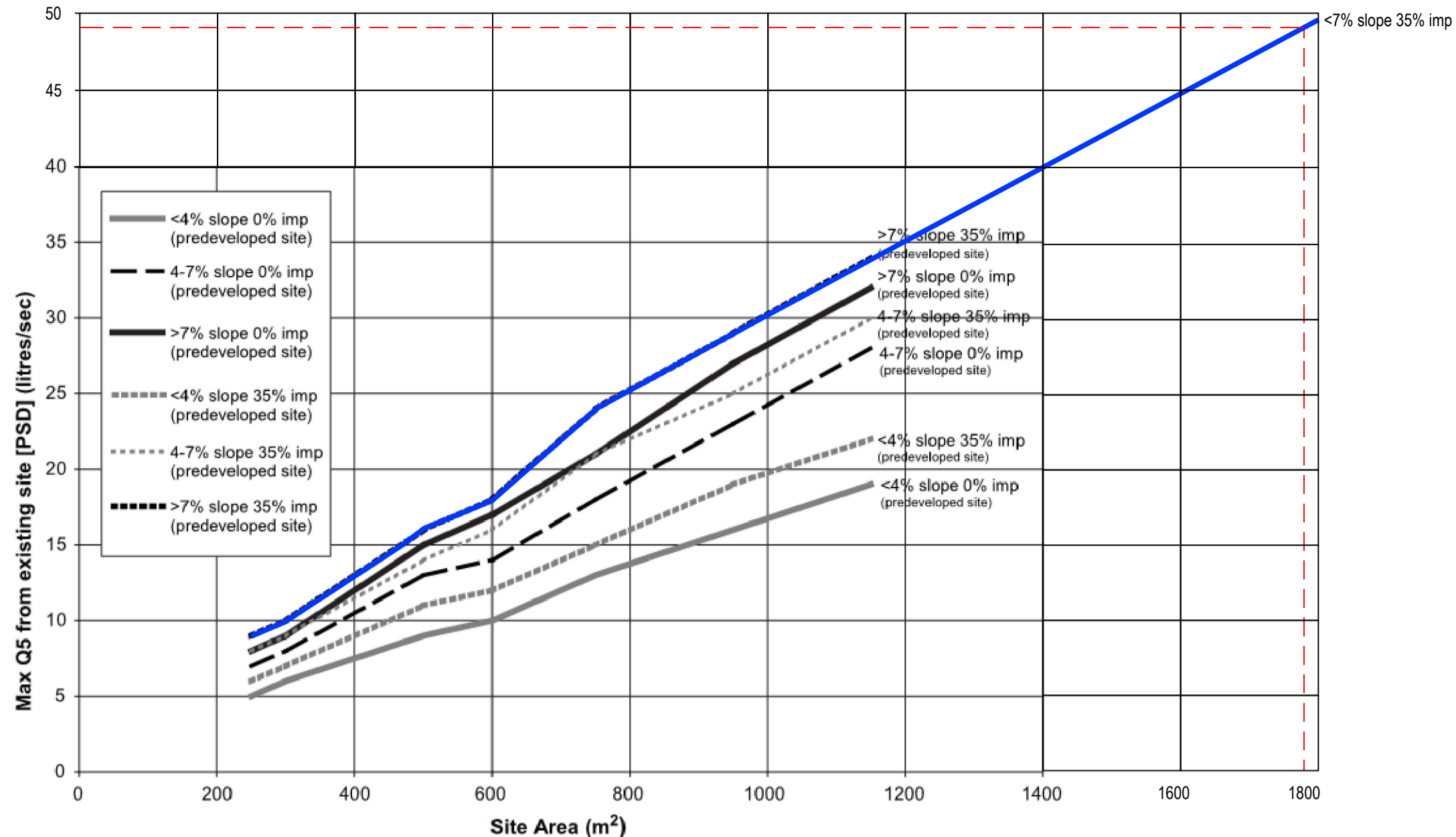

Permissible site discharge

Orifice Plate Calculation		
Formula for orifice plate calculation		
$Q = C.A.\sqrt{(2.g.H)}.10^3$		
Design Discharge Rate	Head over orifice Centre	Recommended Diameter
[L/s]	[m]	[mm]
24	2.330	87

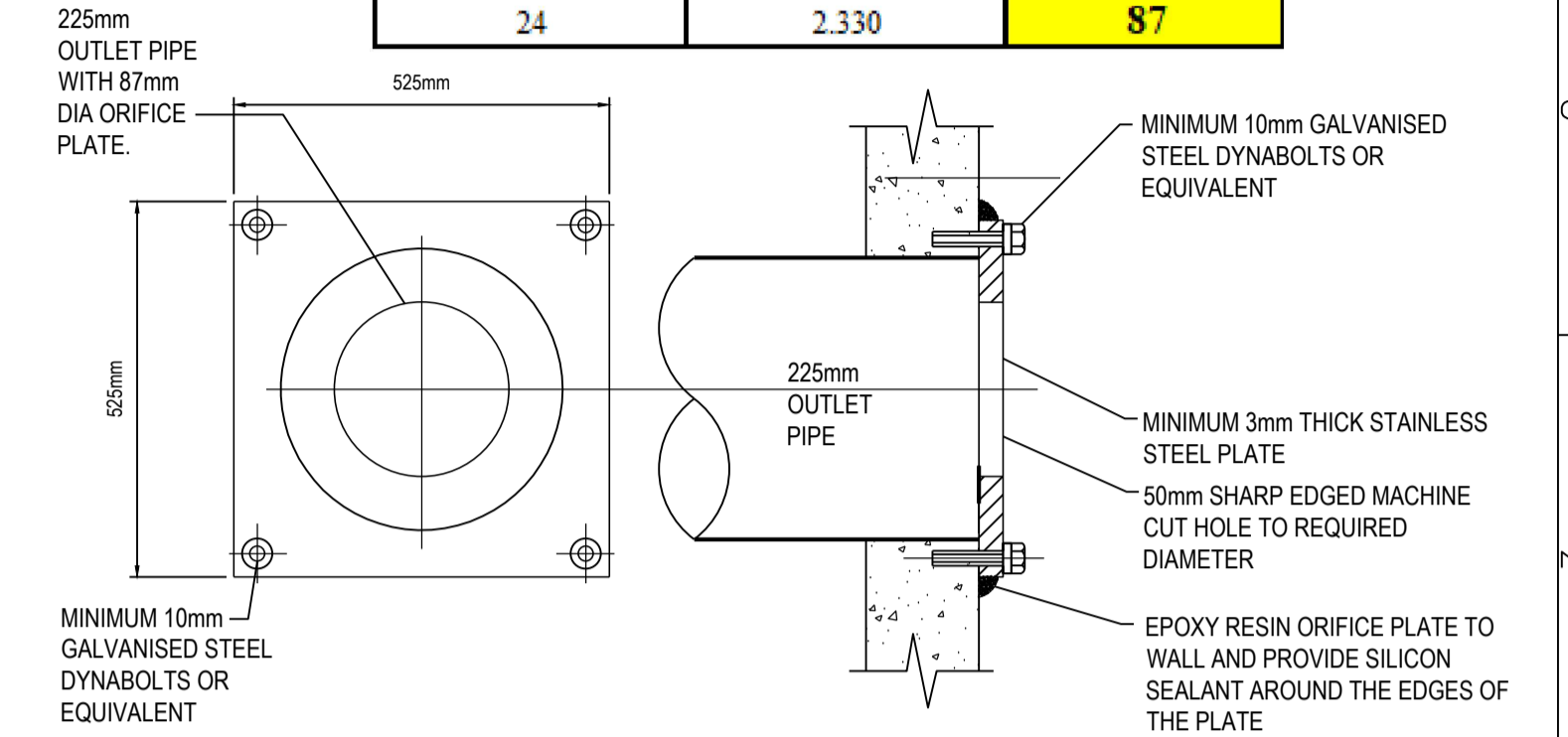

ORIFICE PLATE INSTALLATION NOT TO SCALE

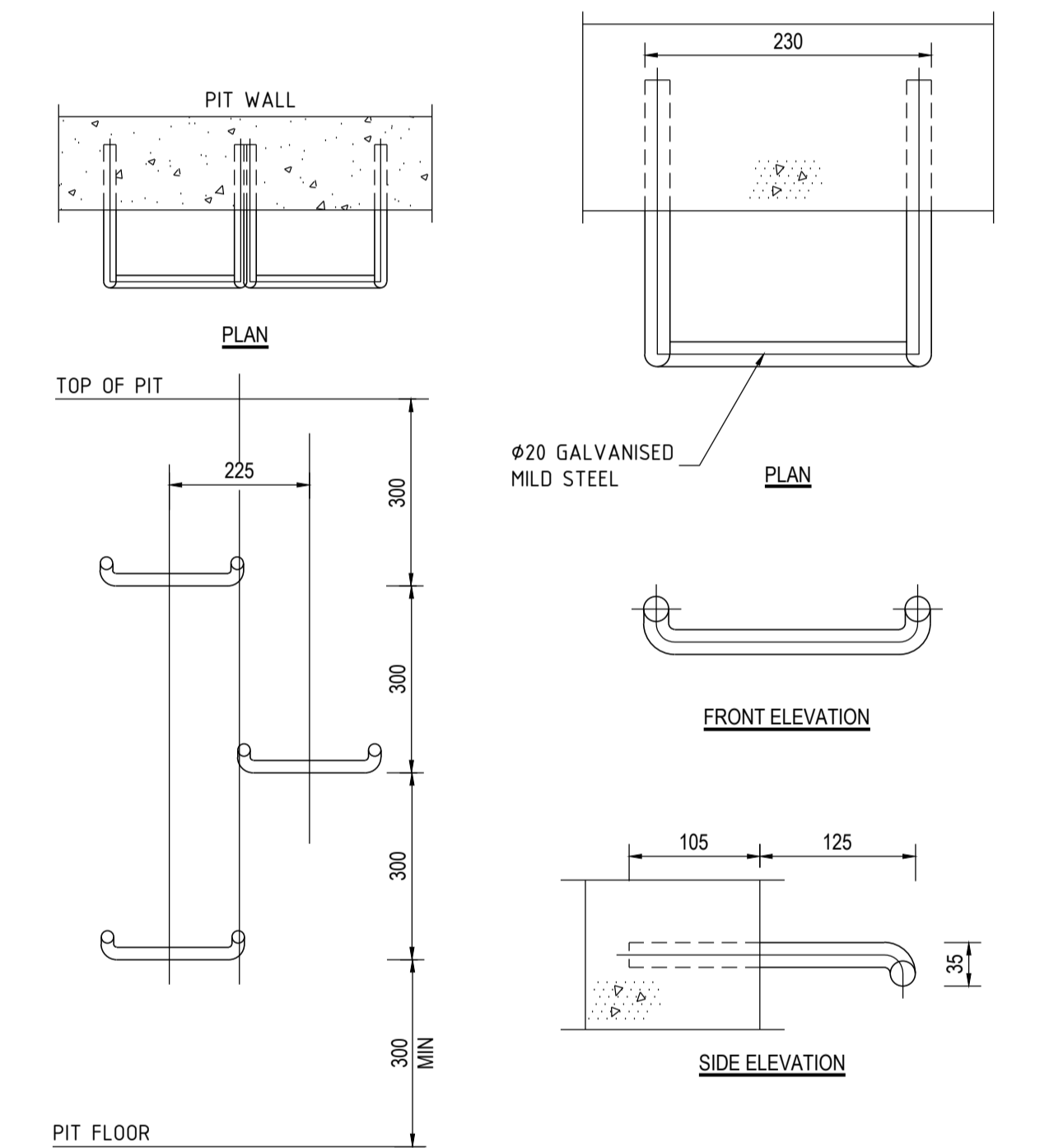
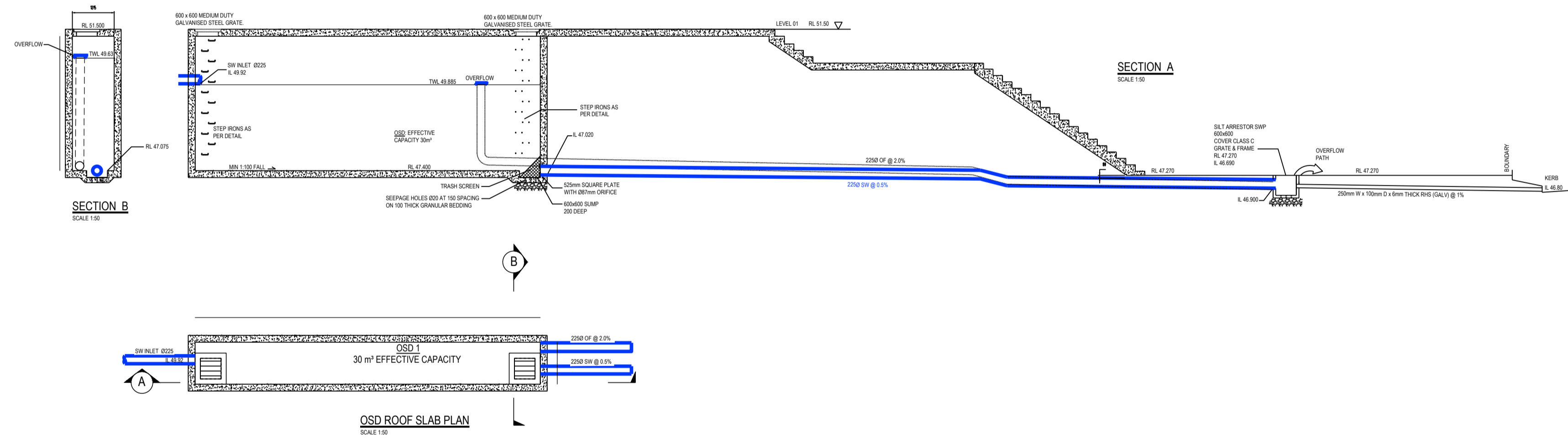

ELEVATION STEP IRON PLACEMENT TO PIT WALL SCALE NTS

STEP IRON DETAIL SCALE 1:5

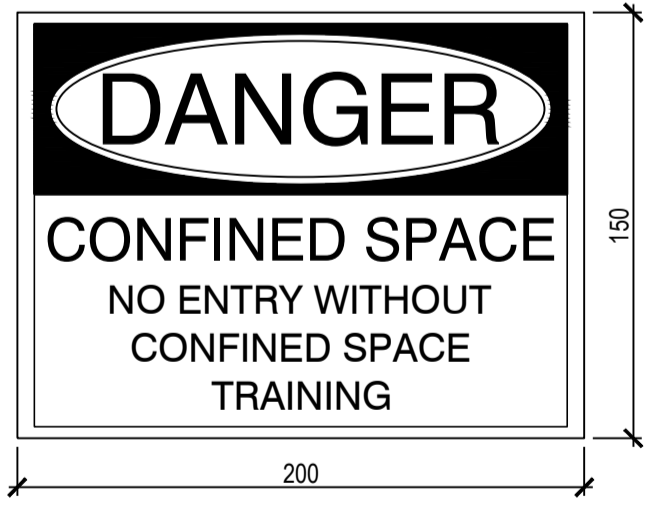

CONFINED SPACE WARNING SIGN TO BE LOCATED AT EACH PIT ENTRANCE OF UNDERGROUND TANK INCLUDING CONTROL PIT.  
 COLOURS: 'DANGER' AND BACKGROUND WHITE  
 ELLIPTICAL AREA RED  
 RECTANGLE CONTAINING ELLIPSE OTHER LETTERING AND BORDER BLACK  
 MATERIAL: POLYPROPYLENE

CONFINED SPACE WARNING SIGN NOT TO SCALE

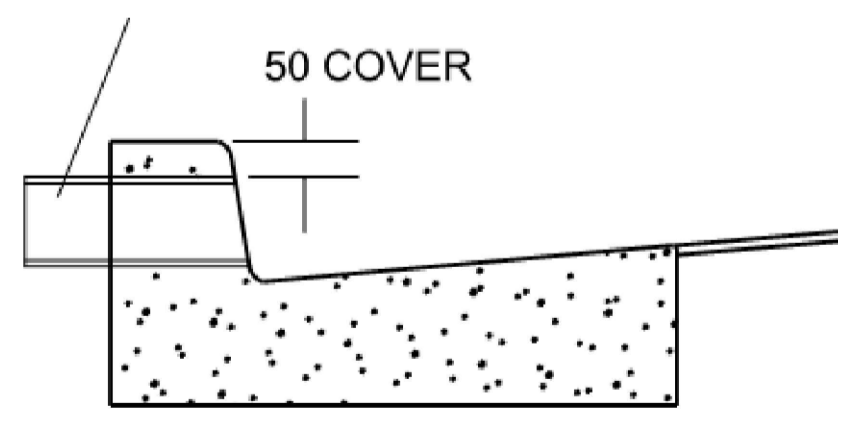

CONNECTION TO KERB DETAIL N.T.S.

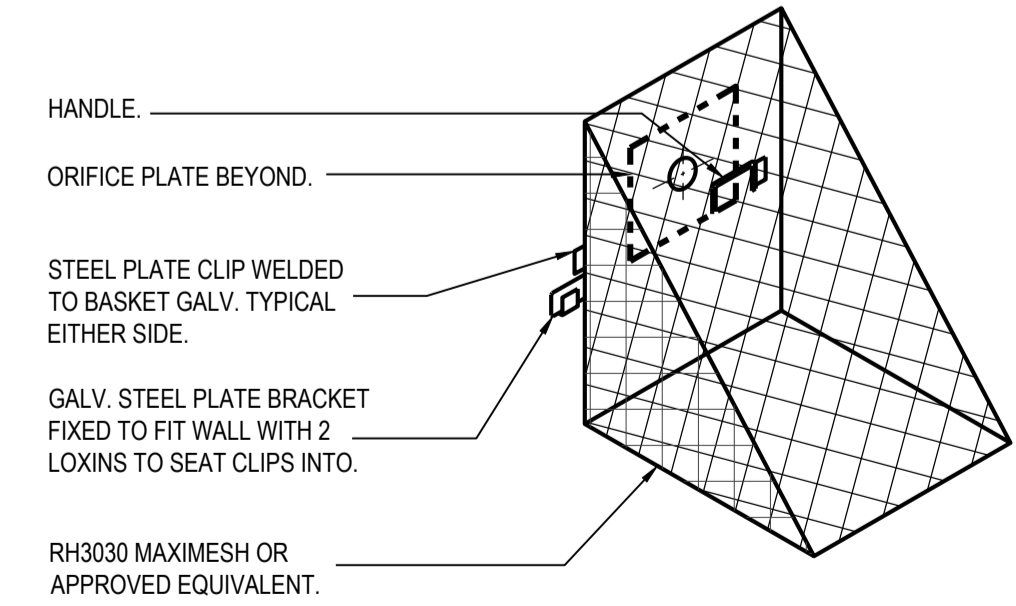

TRASH SCREEN DETAIL NOT TO SCALE

PROPERTY ADDRESS: 195-197 SYDNEY ROAD, FAIRLIGHT  
 SITE AREA: 1789m²  
 AVERAGE SLOPE: 19%  
 PRE-DEVELOPMENT IMPERVIOUS AREA: 695m²  
 POST-DEVELOPMENT IMPERVIOUS AREA: 147m²  
 PROPERTY IS LOCATED WITHIN DENSITY SUB-ZONE 3 & STORMWATER CONTROL ZONE 1  
 PSD = 48 L/s  
 OSD 1 + OSD 2 SIZE = 60m³

AMENDMENTS/REVISIONS				AMENDMENTS/REVISIONS				CLIENT	ARCHITECT	CONSULTANT	PROJECT	DRAWING TITLE	TENDER ISSUE						
Rev	Description	Initials	Date	Rev	Description	Initials	Date					DRAWN	DESIGNED	CHECKED	SCALE (AT FULL SIZE)	DATE			
01	TENDER ISSUE	RH	21.12.20						<b>MOSTAGHIM</b> a L2, 17 federation rd, newtown nsw 2042 w mostaghim.com.au e info@mostaghim.com.au p 02 9557 2002	 <b>IGS</b> INTEGRATED GROUP SERVICES Phone +61 2 8488 4600 Fax +61 2 9475 4588 Address Suite 1.11, 75 Mary St, St Peters, NSW 2044 Australia Web www.igs.com.au	195-197 SYDNEY ROAD FAIRLIGHT	STORMWATER SERVICES DETAIL SHEET OSD 1	RH	GM	MC	1:50 @ A1	FEB 21		
02	TENDER ISSUE	RH	22.12.20																
03	TENDER ISSUE	RH	18.01.21																
04	TENDER ISSUE	RH	04.02.21																
												PROJECT No.	DRAWING No.	REVISION					
												EN-N18_89	H500	04					