

Note:
2,340h Internal doors to Ground Floor
2,040h Internal doors to Upper Floor
R2.5 External Wall Insulation

northern beaches council

THIS PLAN IS TO BE READ IN CONJUNCTION WITH THE CONDITIONS OF DEVELOPMENT CONSENT

DA2020/1642

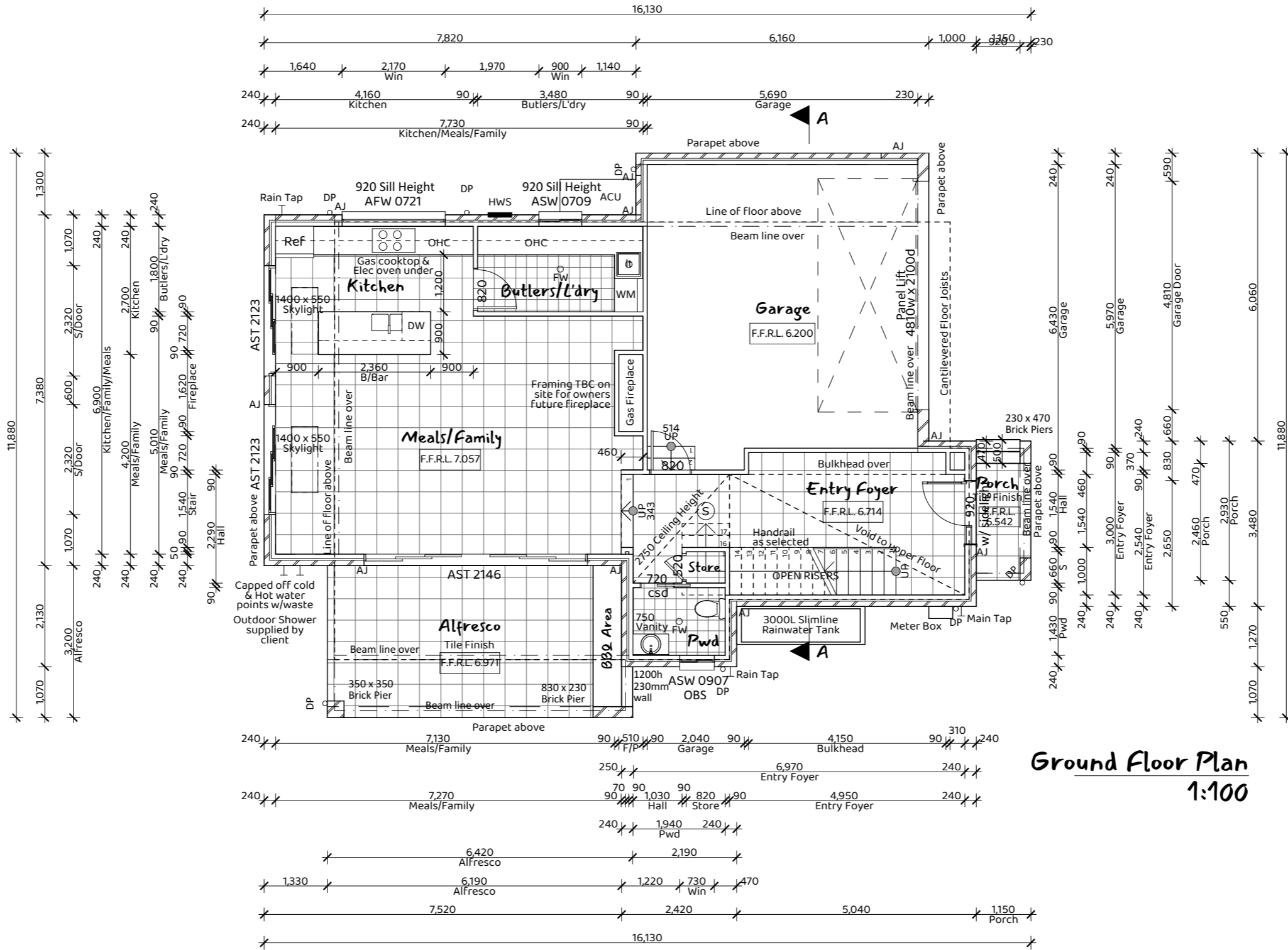

Note:
21.52% Cladded Element - 25% Allowed

Floor Area (m ²)	
Porch	2.94
Alfresco	20.05
Lower Living	84.18
Garage	39.12
Upper Living	100.58
Total	246.87 m²

- Legend:**
- ACU - Air Conditioning Unit
 - AJ - Articulation Joint
 - B/Bar - Breakfast Bar
 - DP - Downpipe
 - DW - Dishwasher
 - Ens - Ensuite
 - F/P - Fire Place
 - FW - Floor Waste
 - HWS - Hot Water System
 - L - Linen
 - LC - Laundry Chute
 - LOH - Lift off Hinge
 - LT - Laundry Tub
 - MH - Manhole
 - MW - Microwave Oven
 - OBS - Obscure
 - OHC - Over Head Cupboard
 - P - Pantry
 - R - Robe
 - RHS - Rolled Hollow Steel
 - S - Smoke Alarm
 - Shr - Shower
 - TR - Towel Rail
 - Van - Vanity
 - w.i.l - Walk in Linen
 - w.i.r. - Walk in Robe
 - w.i.p. - Walk in Pantry
 - w.c. - Wash Closet
 - WM - Washing Machine

issue: **J** drawing: 20166-8 date: 8-12-20 lot: 5
sheet: 3/12 paper: A3 dp: 270907

Havers Residence
#77 Lorikeet Grove, Warriewood
Icon Job Number: J10808

ACCURATE
design & drafting

note: all works to be carried out in conjunction with the construction notes on sheet 2

info@accuratedesign.com.au 02 4647 2552
© abeaut designs t/a Accurate Design and Drafting 2020

Note:
2,340h Internal doors to Ground Floor
2,040h Internal doors to Upper Floor
R2.5 External Wall Insulation



THIS PLAN IS TO BE READ IN CONJUNCTION WITH THE CONDITIONS OF DEVELOPMENT CONSENT

DA2020/1642

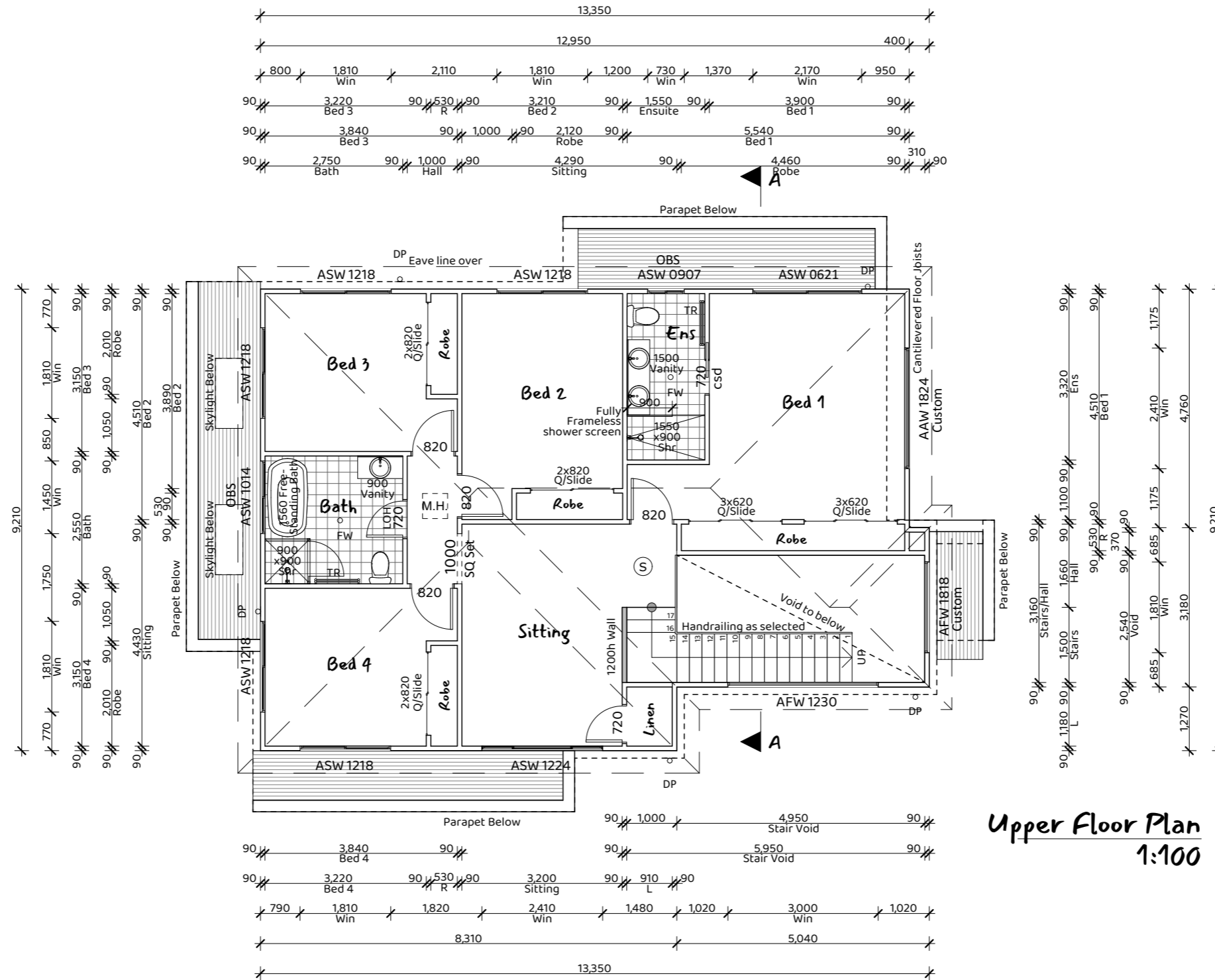

Upper Floor Plan
1:100

Note:
21.52% Cladded Element - 25% Allowed

Floor Area (m ²)	
Porch	2.94
Alfresco	20.05
Lower Living	84.18
Garage	39.12
Upper Living	100.58
Total	246.87 m²

- Legend:**
- ACU - Air Conditioning Unit
 - AJ - Articulation Joint
 - B/Bar - Breakfast Bar
 - DP - Downpipe
 - DW - Dishwasher
 - Ens - Ensuite
 - F/P - Fire Place
 - FW - Floor Waste
 - HWS - Hot Water System
 - L - Linen
 - LC - Laundry Chute
 - LOH - Lift off Hinge
 - LT - Laundry Tub
 - MH - Manhole
 - MW - Microwave Oven
 - OBS - Obscure
 - OHC - Over Head Cupboard
 - P - Pantry
 - R - Robe
 - RHS - Rolled Hollow Steel
 - S - Smoke Alarm
 - Shr - Shower
 - TR - Towel Rail
 - Van - Vanity
 - w.i.l. - Walk in Linen
 - w.i.r. - Walk in Robe
 - w.i.p. - Walk in Pantry
 - w.c. - Wash Closet
 - WM - Washing Machine

issue: **J** drawing: 20166-8 8-12-20 5 date: 8-12-20 5 lot: 5
sheet: 4/12 paper: A3 dp: 270907

Havers Residence
#77 Lorikeet Grove, Warriewood
Icon Job Number: J10808

ACCURATE
design & drafting

note: all works to be carried out in conjunction with the construction notes on sheet 2

info@accuratedesign.com.au 02 4647 2552
© abeaut designs t/a Accurate Design and Drafting 2020

Legend:
 ACU - Air Conditioning Unit
 AJ - Articulation Joint
 CL - Ceiling Level
 FGL - Finish Ground Line
 FL - Floor Level
 HWS - Hot Water System
 NGL - Natural Ground Line
 OBS - Obscure
 DP - Downpipe
 RW - Retaining Wall



THIS PLAN IS TO BE READ IN CONJUNCTION WITH THE CONDITIONS OF DEVELOPMENT CONSENT

DA2020/1642

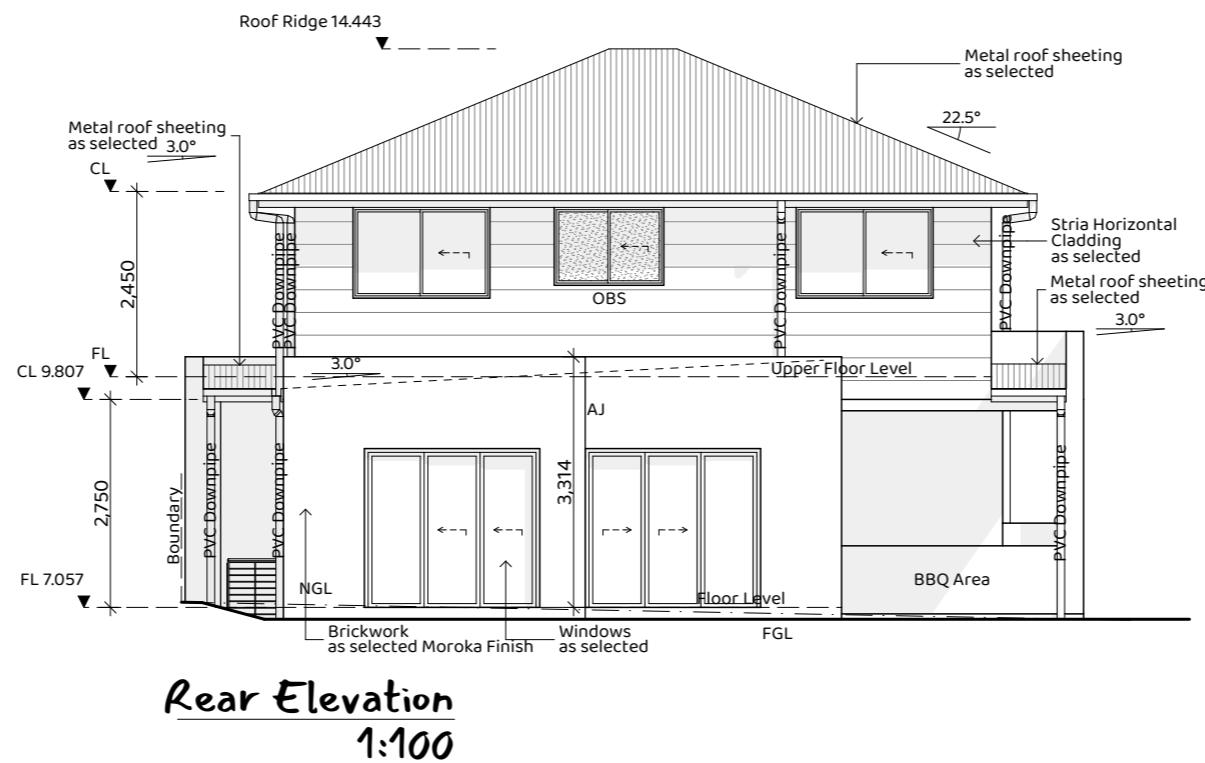
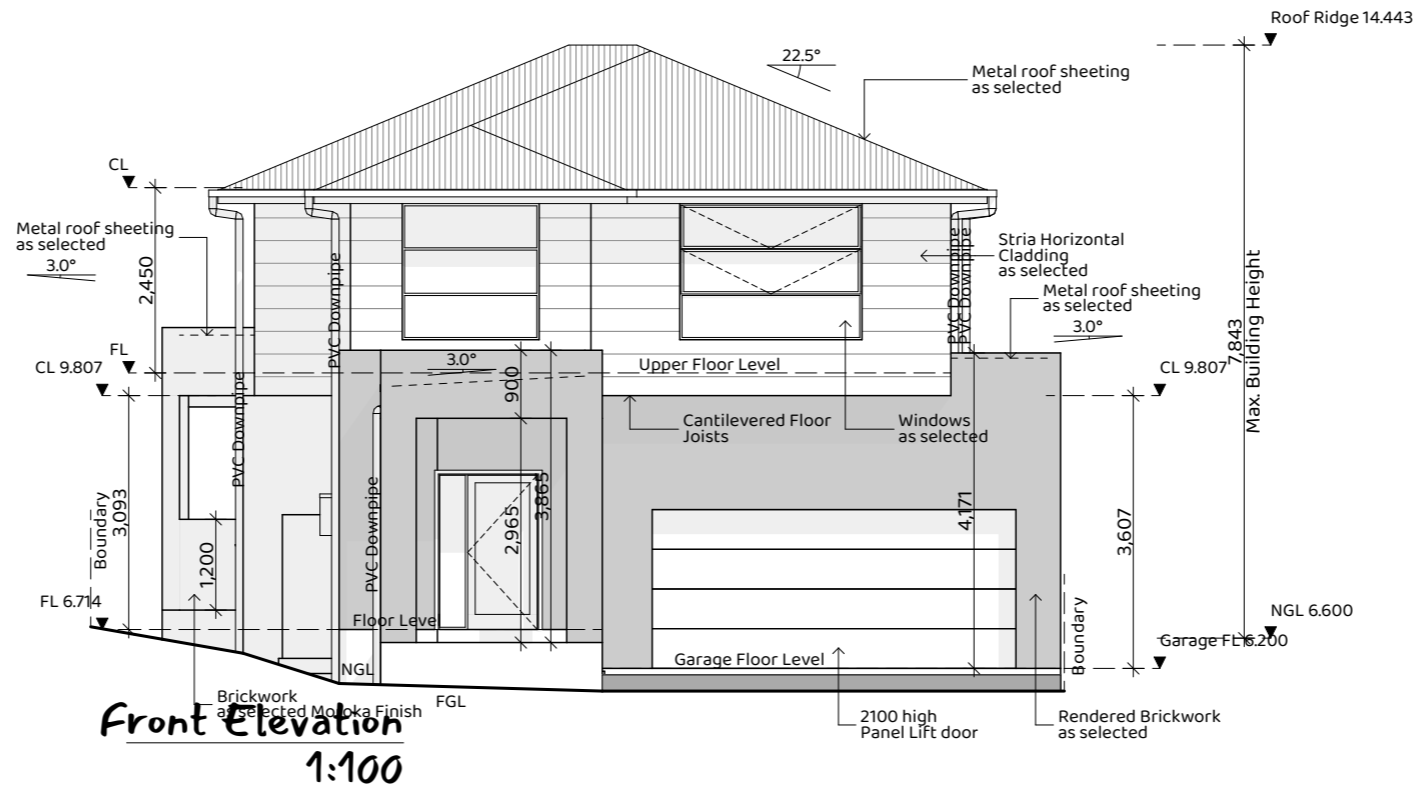

Note:
21.52% Cladded Element - 25% Allowed

issue: **J** drawing: 20166-8 date: 8-12-20 lot: 5
 sheet: 5/12 paper: A3 dp: 270907

note: all works to be carried out in conjunction with the construction notes on sheet 2

Havers Residence
#77 Lorikeet Grove, Warriewood
 Icon Job Number: J/0808

ACCURATE
 design & drafting

info@accuratedesign.com.au 02 4647 2552
 © abeaut designs t/a Accurate Design and Drafting 2020

Legend:
 ACU - Air Conditioning Unit
 AJ - Articulation Joint
 CL - Ceiling Level
 FGL - Finish Ground Line
 FL - Floor Level
 HWS - Hot Water System
 NGL - Natural Ground Line
 OBS - Obscure
 DP - Downpipe
 RW - Retaining Wall



THIS PLAN IS TO BE READ IN CONJUNCTION WITH THE CONDITIONS OF DEVELOPMENT CONSENT

DA2020/1642

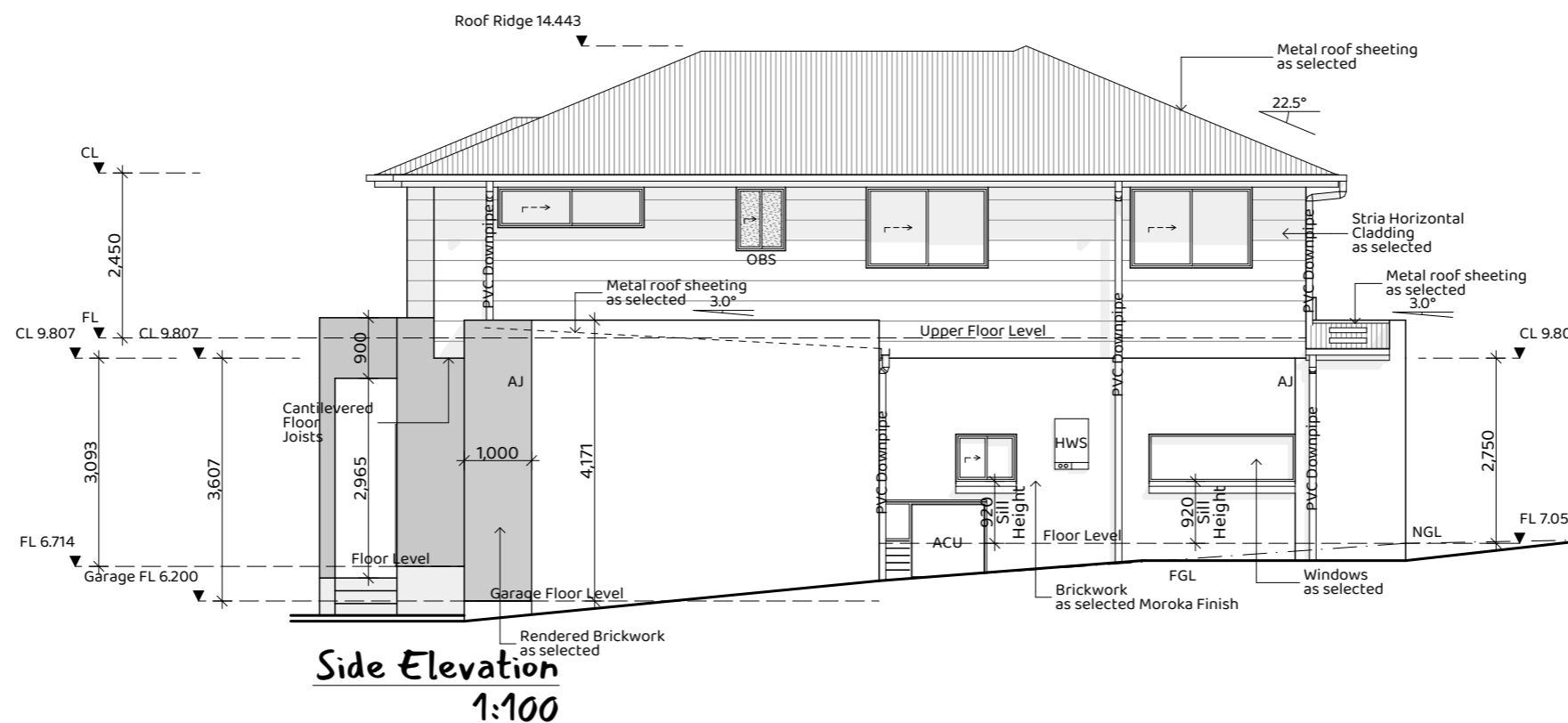
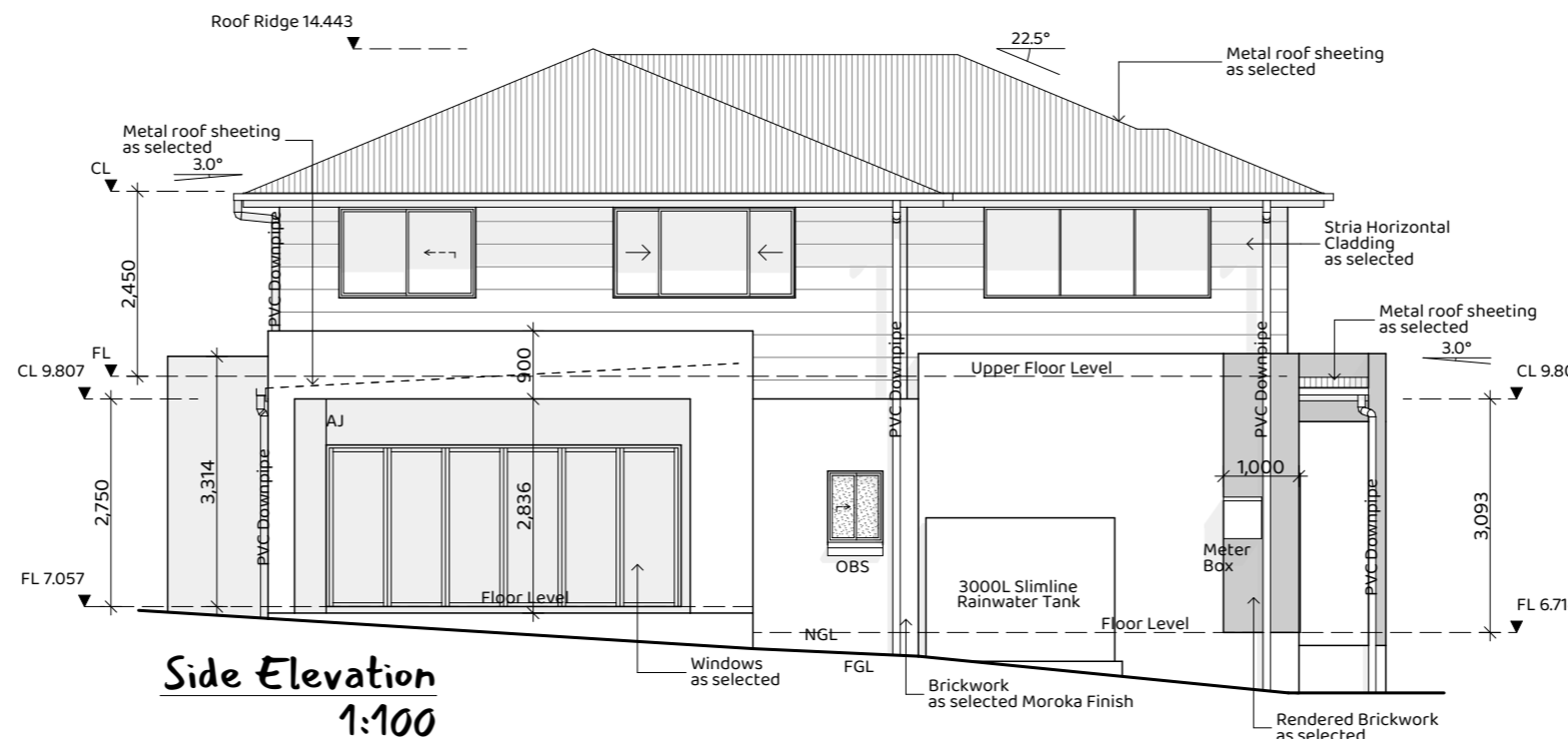

Note:
 21.52% Cladded Element - 25% Allowed

issue: **J** drawing: 20166-8 date: 8-12-20 lot: 5
 sheet: 6/12 paper: A3 dp: 270907

Havers Residence
#77 Lorikeet Grove, Warriewood
 Icon Job Number: J10808

ACCURATE
 design & drafting

note: all works to be carried out in conjunction with the construction notes on sheet 2

info@accuratedesign.com.au 02 4647 2552
 © abeaut designs t/a Accurate Design and Drafting 2020



THIS PLAN IS TO BE READ IN CONJUNCTION WITH THE CONDITIONS OF DEVELOPMENT CONSENT

DA2020/1642

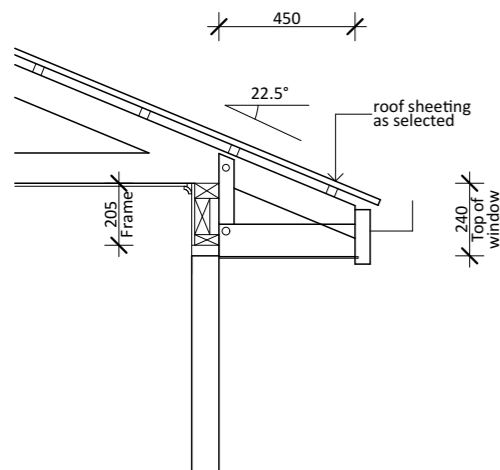

Eave Detail
1:25

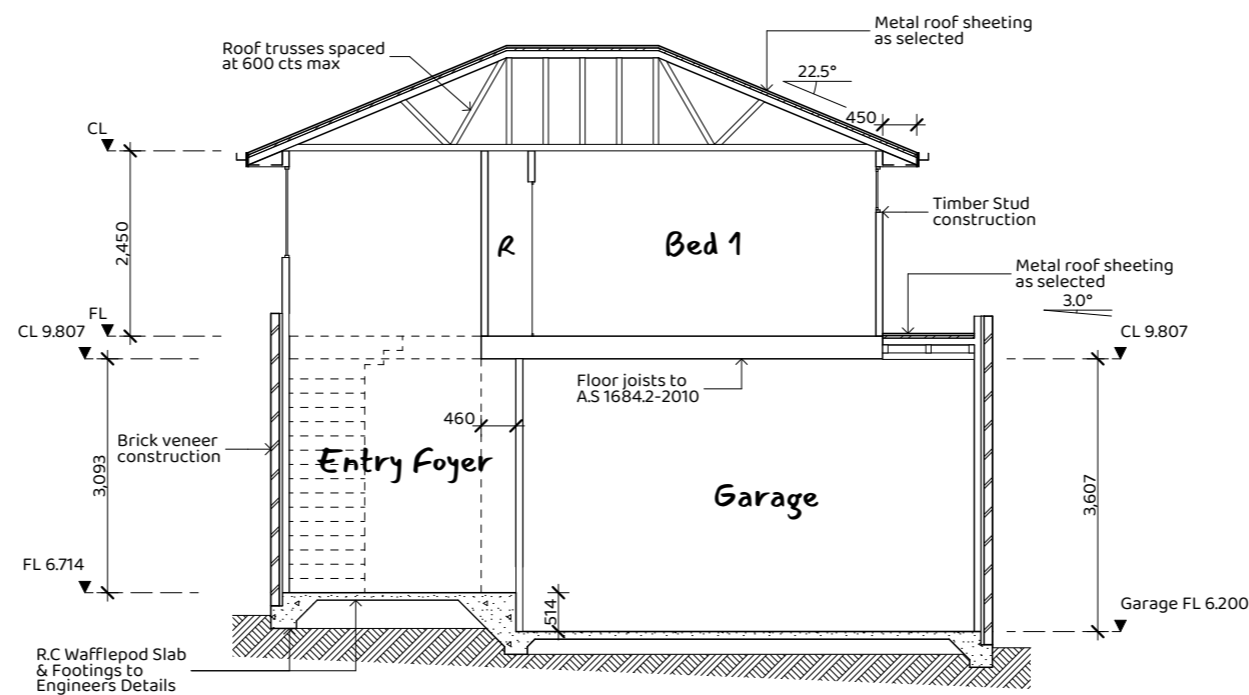

Section A-A
1:100

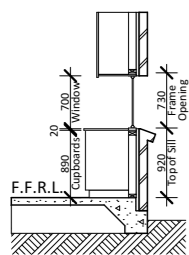

Sill Detail
1:100

issue: **J** drawing: 20166-8 date: 8-12-20 lot: 5
sheet: 7/12 paper: A3 dp: 270907

note: all works to be carried out in conjunction with the construction notes on sheet 2

Havers Residence
#77 Lorikeet Grove, Warriewood
Icon Job Number: J10808

ACCURATE
design & drafting

info@accuratedesign.com.au 02 4647 2552
© abeaut designs t/a Accurate Design and Drafting 2020

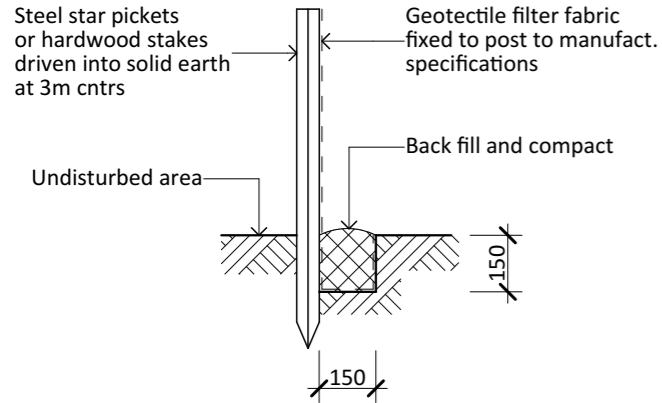

Soil Erosion and Sediment Control Fence
 1. Siltation fencing is to be placed as shown on the site plan as so to prevent silt run off to any adjoining property or to the street. This measure is to be placed prior to any excavation work beginning and is to be removed only when the sites surface as been stabilized, i.e. paved, landscaped or turfed
 2. 40mm crushed rock aggregate is to be placed as an access driveway to the site and must be maintained throughout the course of construction.

Typical Silt Fence
1:20

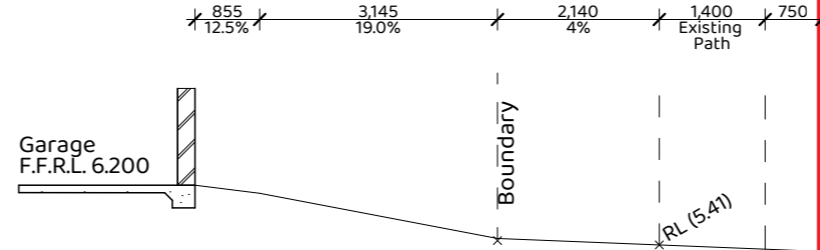
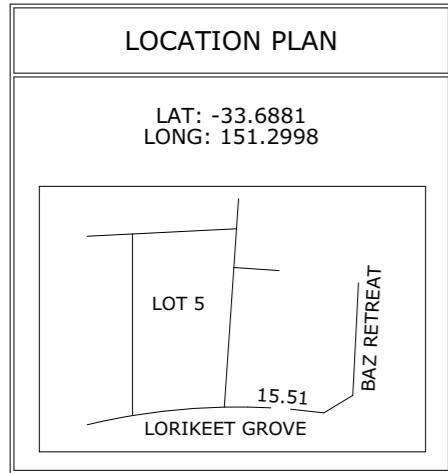

Driveway Profile
1:100

northern beaches council
THIS PLAN IS TO BE READ IN CONJUNCTION WITH THE CONDITIONS OF DEVELOPMENT CONSENT
DA2020/1642

LEGEND	
	BENCH MARK
	PHOTO POINT
	GULLY PIT
	VEHICULAR/PRAM CROSSING
	TOP OF BANK
	BOTTOM OF BANK

ABBREVIATIONS	
EB	- ELECTRICAL BOX
EM	- ELECTRICAL METER
GM	- GAS METER
H	- HYDRANT
KO	- KERB OUTLET
LH	- LAMP HOLE
LP	- LIGHT POLE
MH	- MAN HOLE
MS	- MAINTENANCE SHAFT
PP	- POWER POLE
R	- HYDRANT RECYCLED
SH	- SHRUB
SIO	- SEWER INSPECTION OPENING
SMH	- SEWER MAN HOLE
SR	- STOP VALVE RECYCLED
SV	- STOP VALVE
SVP	- SEWER VENT PIPE
SWP	- STORM WATER PIT
T	- TREE
TP	- TELECOMMUNICATIONS PIT
VER	- VERANDAH
WT	- WATER TAG
WM	- WATER METER
WMR	- WATER METER RECYCLED
WC, GC, EC, TC	- SERVICE CONDUIT
W/C	- WATER CLOSET

SOURCE OF LEVELS	
SSM 24845	RL 12.835
S.C.I.M.S	

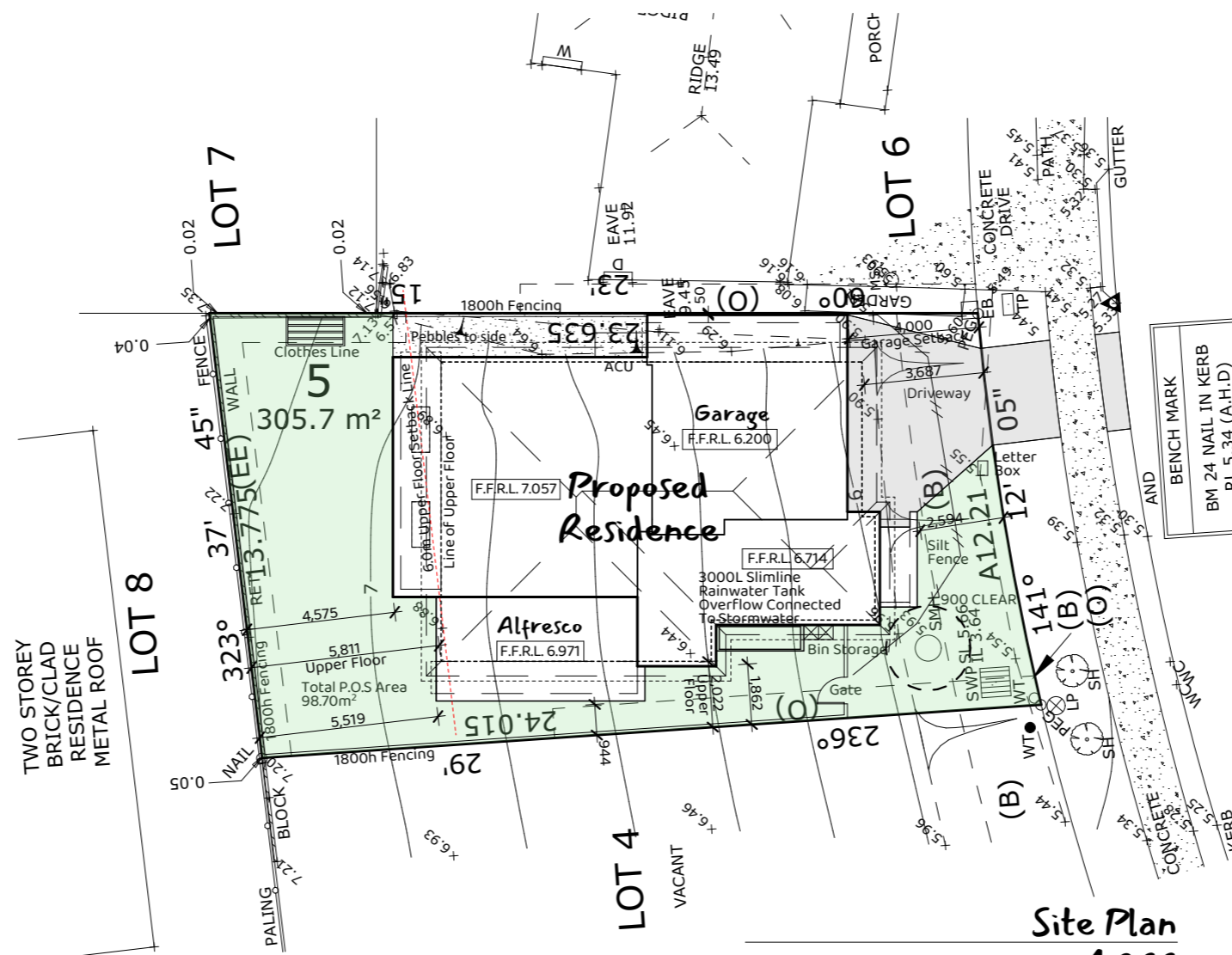

Site Plan
1:200

GROVE
LORIKEET

Lot 5
305.70m²
DP: 270907

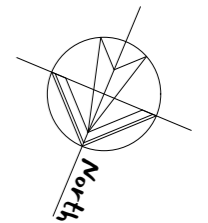

- (B): EASEMENT TO DRAIN WATER 2.5 WIDE (VIDE DP 1206507)
- (EE): EASEMENT FOR ACCESS, MAINTENANCE & SUPPORT 0.9 WIDE
- (O): EASEMENT FOR ACCESS, CONSTRUCTION & MAINTENANCE 0.9 WIDE

issue: **J** drawing: 20166-8 date: 8-12-20 lot: 5
 sheet: 8/12 paper: A3 dp: 270907

Havers Residence
#77 Lorikeet Grove, Warriewood
 Icon Job Number: J10808

ACCURATE
 design & drafting

note: all works to be carried out in conjunction with the construction notes on sheet 2



northern
beaches
council

N...
18.11.2020



**THIS PLAN IS TO BE READ IN
CONJUNCTION WITH
THE CONDITIONS OF DEVELOPMENT
CONSENT**

DA2020/1642



77 Lorikeet Grove Warriewood NSW 2102 – SCHEDULE OF DETAILS AND FINISHES

FINISHES: EXTERIOR



AREA	ITEM	FINISH/COLOUR	DESCRIPTION	IMAGE
ROOF	METAL ROOFING	MONUMENT COLOURBOND		
GUTTER		MONUMENT COLOURBOND		
FASCIA		SHALE GREY COLOURBOND		

NW

18.11.20

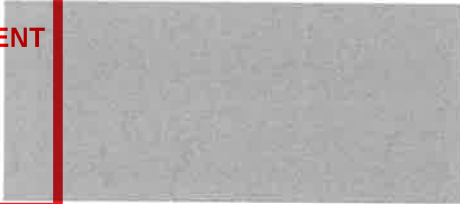
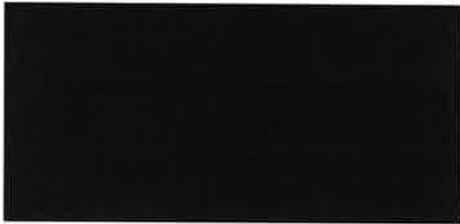

**THIS PLAN IS TO BE READ IN
CONJUNCTION WITH
THE CONDITIONS OF DEVELOPMENT
CONSENT**

DA2020/1642

<p>WINDOWS ARCHITRAVES</p>	<p>TIMBER</p>	<p>SHALE GREY TAUBMANS CB 21</p>	<p>THIS PLAN IS TO BE READ IN CONJUNCTION WITH THE CONDITIONS OF DEVELOPMENT CONSENT</p> <p>DA2020/1642</p>	
<p>WINDOWS</p>	<p>ALUMINIUM</p>	<p>CHARCOAL SATIN</p>		
<p>FRONT DOOR</p>	<p>PAINTED TIMBER</p>	<p>MONUMENT TAUBMANS CB 66</p>	<p>MAIN DOOR- TRANSLUCENT GLASS SIDELIGHT- CLEAR GLASS</p>	
<p>DRIVEWAY</p>	<p>BORAL DECORATIVE CONCRETE</p>	<p>MOONLIGHT</p>	<p>COLOURED CONCRETE</p>	

[Handwritten Signature]
KMM
18.11.20

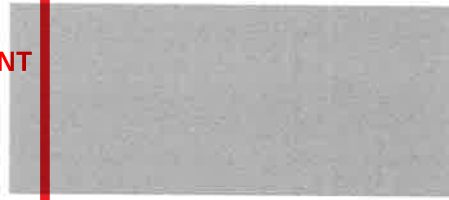
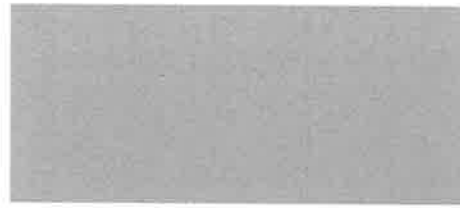
**THIS PLAN IS TO BE READ IN
CONJUNCTION WITH
THE CONDITIONS OF DEVELOPMENT
CONSENT
DA2020/1642**

<p>EAVES + DOWNPIPES</p>	<p>PVC</p>	<p>SHALE GREY TAUBMANS CB 21</p>	<p>THIS PLAN IS TO BE READ IN CONJUNCTION WITH THE CONDITIONS OF DEVELOPMENT CONSENT DA2020/1642</p>	
<p>FIRST FLOOR WALLS- INCLUDING FAÇADE, REAR AND BOTH SIDE ELEVATIONS</p>	<p>JAMES HARDIE CLADDING</p>	<p>SHALE GREY TAUBMANS CB 21</p>	<p>STRIA 405MM (HORIZONTAL)</p>	
<p>GROUND FLOOR FACADE WALLS</p>	<p>CAVITY BRICKWORK RENDERED</p>	<p>GEMINI SILVER TAUBMANS NH 46</p>	<p>RENDER 1</p>	
<p>GROUND FLOOR SIDE ELEVATIONS AND REAR</p>	<p>CAVITY BRICKWORK MOROKA</p>	<p>GEMINI SILVER TAUBMANS NH 46</p>	<p>MOROKA</p>	