

Arboricultural Impact Statement Report

Written as per Australian Standard 4970-2009

**130-132 Elanora Road
Elanora Heights
NSW 2101**

Prepared by Mark Bury Consulting

ABN: 53 797 009 569

AQF Level 5 Arborist Hortus Australia National Code 1042

Diploma of Horticulture/Arboriculture Parchment Number 6621

31st January 2006 Course Code RTF50203

International Society of Arboriculture Credential Licence Au-0345AM

PO Box 6082 Kincumber NSW

E-mail mark.bury@bigpond.com

Phone 0400485878

14th October 2019

Contents

1. Synopsis	3
2. Background/Brief	3
3. Method of Assessment	4
4. Site Analysis	4
5. Discussion	5
6. Overall Recommendations from Arboricultural assessment and Development impact Statements	12
Appendix 2 - Site Photographs	16
Appendix 3 - SULE Safe Useful Life Expectancy (Barell 1995)	26
Appendix 4 - Overall Site Map and Tree Locations	53
Appendix 5 - Brief Qualifications and Experience of Mark Bury	54
Appendix 6 - Construction Impact Statement	59
Appendix 7 - Tree Protection Plan	63
Appendix 8 - Bibliography / References	77
Appendix 9 - Root Management Systems	81
Appendix 10 - Arborist Report Required	82
Appendix 11 - Disclaimer	84

1. Synopsis

This report advises and concludes that sixteen (16) trees located on the proposed development site can be preserved as part of the proposed development (Sub Division) for the site. This report has been based on the plans forwarded to me by the client in Appendix 4. Report has been written as per specification for Northern Beaches Council Specifications in Appendix 10 of this report. Seven (7) trees (5, 6, 7, 8, 9, 10, and 14) will require removal for the proposed sub division works to be carried out.

Arboricultural Impact Report on: Twenty three (23) Trees

Tree Inspection: 14th October 2019

Report Prepared: 14th October 2019

Report Commissioned by: Elias Metry Director
STUDIOEM
Suite 2, Level 1,
46 Birmingham Street,
Alexandria NSW 2015

Legislation:

Northern Beaches Council Tree Preservation, Order, DCP and Local Environment Plan, Section 74C of the Environmental Planning and Assessment Act 1979 (EP&A Act) NSW Native Vegetation Act 2003, NSW Native Vegetation Regulation 2005, NSW Fisheries Management Act 1994, NSW Threatened Species Conservation Act 1995, New South Wales Heritage Act 1977, NSW Rural Fires Act 1997, NSW Water Act 2000, NSW Threatened Species Conservation Act 1995, Federal National Parks and Wildlife Act 1974, Protection of the Environment Operations Act 1997 and the Federal Environment Protection and Biodiversity Conservation Act 1999

Scope of Works:

To determine the effects of the proposed development (See Appendix 4) at 130-132 Elanora Road Elanora Heights on twenty three (23) trees located on the property See Appendix 4 proposed development.

2. Background/Brief

- 2.1 Elias Metry has requested an Arboricultural Impact Statement report on twenty three (23) trees located on the property to determine their suitability for retention on the site as part of a proposed development for the site.
- 2.2 A visual tree inspection (VTA) of the trees was carried out by Mark Bury. The inspection included observing branch structure and condition, any insect or disease damage, inspection of surface roots and observations of the tree canopy. The inspection also involved measuring the height, canopy and diameter at breast height and diameter at base height

of the tree. An onsite inspection occurred on 14th October 2019 at the location. No aerial (climbing inspections) were taken as part of the assessment.

- 2.3 The conclusions and recommendations contained in this assessment are based on the aforementioned inspection and discussions.

3. Method of Assessment

- 3.1 The site was inspected on 14th October 2019. An objective visual inspection was made from the ground of the health and condition of the tree. This assessment has been carried out in reference to the accepted methods of tree assessment by Mattheck and Breloer (VTA) Page 119 of The Body Language of Trees and Strouts and Winter (Page 1) in Diagnosis of ill health in trees A Tree Schedule (Appendix 3) Binoculars were used to inspect the crown of the tree. Trees on the property have been tagged with numbers.
- 3.2 Photographs used in this report are originals taken at the inspection and are not altered in any way. Tree heights are determined with a Silva Clinomaster/Heightmeter™ and canopy spread were determined by visual estimations. Soil compaction was assessed by using an 8mm x 400mm steel spike being pushed by hand vertically into the ground. Soil samples were tested using a pH Meter and confirmed using a Manutec pH Soil Kit. Tree Protection Zones and Structural Root Zones are calculated using the Australian Standard AS 4970-2009 Protection of Trees on Development Sites. From this information conclusions were drawn.
- 3.3 The tree root zone has been inspected and unless stated in this report are stable except for were stated. The tree has not displayed the normal signs of root plate shear failure on the day of this inspection the 14th October 2019. This was a visual inspection only and I have little history of works which involved work in the root zone of the tree which could affect the stability of the tree in the future.

4. Site Analysis

- 4.1 The site is located in Elanora Heights on the western side of South Western Side of Elanora Road Elanora Heights. The site is a medium density residential property located on a sloping site. The site is considered not to be urban bushland. The site is less than 1km to any area of bushland.
- 4.2 The trees are planted on Hawkesbury (ha) soils that have limitations of extreme soil erosion hazard, steep slopes, rocky outcrop, shallow, stoney, highly permeable soil, low soil fertility
- 4.3 These species of trees normally do well in this soil type and some are indigenous to this area of Elanora Heights. I stress that my inspection of this site was of an ISA Level 2 Inspection and did not involve any climbing or detailed investigation beyond what was visible from accessible points at ground level.

5. Discussion

- 5.1 **Tree 1** (*Eucalyptus microcorys* Tallowood **Street Tree**) is a tree in poor condition Appendix 1 gives a description of the tree as per AS-4970-2009 Section 2. Appendix 4 gives the location of the tree on the property.
- 5.2 The tree will not be affected by the proposed development (See Appendix 6 Construction Impact Statement). The trees soil and hydrological environments will not be affected by the proposed development. The tree should be preserved
- 5.3 The tree should be managed as per appendix 7 (Tree Protection Plan) and regular compliance inspections should be carried out to ensure trees root zone is not being impacted by the proposed works and trunk protection works have been carried out.
- 5.4 **Tree 2** (*Angophora costata* Sydney Red Gum **Street Tree**) is a tree in poor condition Appendix 1 gives a description of the tree as per AS-4970-2009 Section 2. Appendix 4 gives the location of the tree on the property.
- 5.5 The tree not will be affected by the proposed development (See Appendix 6 Construction Impact Statement). The trees soil and hydrological environments will not be affected by the proposed development. The tree should be preserved
- 5.6 The tree should be managed as per appendix 7 (Tree Protection Plan) and regular compliance inspections should be carried out to ensure trees root zone is not being impacted by the proposed works and trunk protection works have been carried out.
- 5.7 **Tree 3** (*Ficus rubiginosa* Port Jackson Fig) is a tree in fair condition Appendix 1 gives a description of the tree as per AS-4970-2009 Section 2. Appendix 4 gives the location of the tree on the property.
- 5.8 The tree will not be affected by the proposed development (See Appendix 6 Construction Impact Statement). The trees soil and hydrological environments will not be affected by the proposed development. Appropriate tree management in this situation would be the preservation of the tree
- 5.9 The tree should be preserved it should be managed as per appendix 7 (Tree Protection Plan) and regular compliance inspections should be carried out to ensure trees root zone is not being impacted by the proposed works and trunk protection works have been carried out.
- 5.10 **Tree 4** (*Eucalyptus microcorys* Tallowood) is a tree in fair condition Appendix 1 gives a description of the tree as per AS-4970-2009 Section 2. Appendix 4 gives the location of the tree on the property.

- 5.11 The tree will not be affected by the proposed development (See Appendix 6 Construction Impact Statement). The trees soil and hydrological environments will not be affected by the proposed development. Appropriate tree would be the preservation of the tree
- 5.12 The tree should be managed as per appendix 7 (Tree Protection Plan) and regular compliance inspections should be carried out to ensure trees root zone is not being impacted by the proposed works and trunk protection works have been carried out.
- 5.13 **Tree 5** (*Eucalyptus saligna* Sydney Blue Gum) is a tree in fair condition Appendix 1 gives a description of the tree as per AS-4970-2009 Section 2. Appendix 4 gives the location of the tree on the property.
- 5.14 The tree will be affected by the proposed development (See Appendix 6 Construction Impact Statement). The trees soil and hydrological environments will be affected by the proposed development. Appropriate tree management in this situation would be the removal of the tree.
- 5.15 The tree should be replaced in the proposed landscape plan for the site.
- 5.16 **Tree 6** (*Eucalyptus microcorys* Tallowood) is a tree in fair condition Appendix 1 gives a description of the tree as per AS-4970-2009 Section 2. Appendix 4 gives the location of the tree on the property.
- 5.17 The tree will be affected by the proposed development (See Appendix 6 Construction Impact Statement). The trees soil and hydrological environments will be affected by the proposed development. Appropriate tree management in this situation would be the removal and replacement of the tree as per the aims of the Development Control plan for Northern Beaches Council in the landscape plan for the site with a suitable replacement species in better sited location
- 5.18 The tree should be replaced in the proposed landscape plan for the site
- 5.19 If the tree is to be preserved it should be managed as per appendix 7 (Tree Protection Plan) and regular compliance inspections should be carried out to ensure trees root zone is not being impacted by the proposed works and trunk protection works have been carried out
- 5.20 **Tree 7** (*Eucalyptus microcorys* Tallowood) is a tree in fair condition Appendix 1 gives a description of the tree as per AS-4970-2009 Section 2. Appendix 4 gives the location of the tree on the property.
- 5.21 The tree will be affected by the proposed development (See Appendix 6 Construction Impact Statement). The trees soil and hydrological environments will be affected by the proposed development. Appropriate tree management in this situation would be the removal and replacement of the tree as per the aims of the Development Control plan for Northern Beaches Council in the landscape plan for the site with a suitable replacement species in better sited

location

- 5.22 The tree should be replaced in the proposed landscape plan for the site
- 5.23 If the tree is to be preserved it should be managed as per appendix 7 (Tree Protection Plan) and regular compliance inspections should be carried out to ensure trees root zone is not being impacted by the proposed works and trunk protection works have been carried out
- 5.24 **Tree 8** (*Eucalyptus microcorys* Tallowood) is a tree in fair condition Appendix 1 gives a description of the tree as per AS-4970-2009 Section 2. Appendix 4 gives the location of the tree on the property.
- 5.25 The tree will be affected by the proposed development (See Appendix 6 Construction Impact Statement). The trees soil and hydrological environments will be affected by the proposed development. Appropriate tree management in this situation would be the removal and replacement of the tree as per the aims of the Development Control plan for Northern Beaches in the landscape plan for the site with a suitable replacement species in better sited location
- 5.26 The tree should be replaced in the proposed landscape plan for the site
- 5.27 If the tree is to be preserved it should be managed as per appendix 7 (Tree Protection Plan) and regular compliance inspections should be carried out to ensure trees root zone is not being impacted by the proposed works and trunk protection works have been carried out.
- 5.28 **Tree 9** (*Liquidambar styraciflua* Liquidamber) is a tree in fair condition Appendix 1 gives a description of the tree as per AS-4970-2009 Section 2. Appendix 4 gives the location of the tree on the property.
- 5.29 The tree should be replaced in the proposed landscape plan for the site
- 5.30 If the tree is to be preserved it should be managed as per appendix 7 (Tree Protection Plan) and regular compliance inspections should be carried out to ensure trees root zone is not being impacted by the proposed works and trunk protection works have been carried out
- 5.31 If the tree is to be preserved it should be managed as per appendix 7 (Tree Protection Plan) and regular compliance inspections should be carried out to ensure trees root zone is not being impacted by the proposed works and trunk protection works have been carried out
- 5.32 **Tree 10** (*Eucalyptus microcorys* Tallowood) is a tree in fair condition Appendix 1 gives a description of the tree as per AS-4970-2009 Section 2. Appendix 4 gives the location of the tree on the property.
- 5.33 The tree will be affected by the proposed development (See Appendix 6 Construction Impact Statement). The trees soil and hydrological environments will be affected by the proposed development. Appropriate tree management in this situation would be the removal and replacement of the tree as per the aims

of the Development Control plan for Northern Beaches Council in the landscape plan for the site with a suitable replacement species in better sited location

- 5.34 The tree should be replaced in the proposed landscape plan for the site
- 5.35 If the tree is to be preserved it should be managed as per appendix 7 (Tree Protection Plan) and regular compliance inspections should be carried out to ensure trees root zone is not being impacted by the proposed works and trunk protection works have been carried out.
- 5.36 **Tree 11** (*Corimbya gummifera* Red Bloodwood) is a tree in fair condition Appendix 1 gives a description of the tree as per AS-4970-2009 Section 2. Appendix 4 gives the location of the tree on the property.
- 5.37 The tree will not be affected by the proposed development (See Appendix 6 Construction Impact Statement). The trees soil and hydrological environments will not be affected by the proposed development. Appropriate tree management in this situation would be the preservation of the tree.
- 5.38 The tree should be managed as per appendix 7 (Tree Protection Plan) and regular compliance inspections should be carried out to ensure trees root zone is not being impacted by the proposed works and trunk protection works have been carried out.
- 5.39 **Tree 12** (*Lophostemon confertus* Brushbox) is a tree in fair condition Appendix 1 gives a description of the tree as per AS-4970-2009 Section 2. Appendix 4 gives the location of the tree on the property.
- 5.40 The tree will not be affected by the proposed development (See Appendix 6 Construction Impact Statement). The trees soil and hydrological environments will not be affected by the proposed development. Appropriate tree management in this situation would be the preservation of the tree.
- 5.41 The tree should be managed as per appendix 7 (Tree Protection Plan) and regular compliance inspections should be carried out to ensure trees root zone is not being impacted by the proposed works and trunk protection works have been carried out
- 5.42 **Tree 13** (*Ficus rubiginosa* Port Jackson Fig) is a tree in fair condition Appendix 1 gives a description of the tree as per AS-4970-2009 Section 2. Appendix 4 gives the location of the tree on the property.
- 5.43 The tree will not be affected by the proposed development (See Appendix 6 Construction Impact Statement). The trees soil and hydrological environments will not be affected by the proposed development. Appropriate tree management in this situation would be the preservation of the tree.
- 5.44 The tree should be managed as per appendix 7 (Tree Protection Plan) and regular compliance inspections should be carried out to ensure trees root zone is not being impacted by the proposed works and trunk protection works have

been carried out

- 5.45 **Tree 14** (*Eucalyptus paniculata* Grey Ironbark) is a tree in fair condition Appendix 1 gives a description of the tree as per AS-4970-2009 Section 2. Appendix 4 gives the location of the tree on the property.
- 5.46 The tree will be affected by the proposed development (See Appendix 6 Construction Impact Statement). The trees soil and hydrological environments will be affected by the proposed development. Appropriate tree management in this situation would be the removal and replacement of the tree as per the aims of the Development Control plan for Northern Beaches in the landscape plan for the site with a suitable replacement species in better sited location
- 5.47 The tree should be replaced in the proposed landscape plan for the site
- 5.48 If the tree is to be preserved it should be managed as per appendix 7 (Tree Protection Plan) and regular compliance inspections should be carried out to ensure trees root zone is not being impacted by the proposed works and trunk protection works have been carried out
- 5.49 **Tree 15** (*Angophora costata* Sydney Red Gum) is a tree in fair condition Appendix 1 gives a description of the tree as per AS-4970-2009 Section 2. Appendix 4 gives the location of the tree on the property.
- 5.50 The tree will not be affected by the proposed development (See Appendix 6 Construction Impact Statement). The trees soil and hydrological environments will not be affected by the proposed development. Appropriate tree management in this situation would be the preservation of the tree
- 5.51 If the tree is to be preserved it should be managed as per appendix 7 (Tree Protection Plan) and regular compliance inspections should be carried out to ensure trees root zone is not being impacted by the proposed works and trunk protection works have been carried out
- 5.52 **Tree 16** (*Angophora costata* Sydney Red Gum) is a tree in fair condition Appendix 1 gives a description of the tree as per AS-4970-2009 Section 2. Appendix 4 gives the location of the tree on the property.
- 5.53 The tree will not be affected by the proposed development (See Appendix 6 Construction Impact Statement). The trees soil and hydrological environments will not be affected by the proposed development. Appropriate tree management in this situation would be the preservation of the tree
- 5.54 If the tree is to be preserved it should be managed as per appendix 7 (Tree Protection Plan) and regular compliance inspections should be carried out to ensure trees root zone is not being impacted by the proposed works and trunk protection works have been carried out
- 5.55 **Tree 17** (*Eucalyptus haemastoma* Scribbly Gum) is a tree in poor condition (Dead/Dying) Appendix 1 gives a description of the tree as per AS-4970-2009 Section 2. Appendix 4 gives the location of the tree on the property.

- 5.56 The tree will not be affected by the proposed development (See Appendix 6 Construction Impact Statement). The trees soil and hydrological environments will not be affected by the proposed development. Appropriate tree management in this situation would be the preservation of the tree for development, for its removal because of its poor condition a separate application under Northern Beaches Council Tree Preservation Order would be required.
- 5.57 If the tree is to be preserved it should be managed as per appendix 7 (Tree Protection Plan) and regular compliance inspections should be carried out to ensure trees root zone is not being impacted by the proposed works and trunk protection works have been carried out
- 5.58 **Tree 18** *Eucalyptus haemastoma* Scribbly Gum) is a tree in poor condition (Dead/Dying) Appendix 1 gives a description of the tree as per AS-4970-2009 Section 2. Appendix 4 gives the location of the tree on the property.
- 5.59 The tree will not be affected by the proposed development (See Appendix 6 Construction Impact Statement). The trees soil and hydrological environments will not be affected by the proposed development. Appropriate tree management in this situation would be the preservation of the tree for development, for its removal because of its poor condition a separate application under Northern Beaches Council Tree Preservation Order would be required.
- 5.60 If the tree is to be preserved it should be managed as per appendix 7 (Tree Protection Plan) and regular compliance inspections should be carried out to ensure trees root zone is not being impacted by the proposed works and trunk protection works have been carried out
- 5.61 **Tree 19** (*Macadamia integrifolia* Macadamia) is a tree in fair condition Appendix 1 gives a description of the tree as per AS-4970-2009 Section 2. Appendix 4 gives the location of the tree on the property.
- 5.62 The tree will not be affected by the proposed development (See Appendix 6 Construction Impact Statement). The trees soil and hydrological environments will not be affected by the proposed development. Appropriate tree management in this situation would be the preservation of the tree.
- 5.63 The tree should be managed as per appendix 7 (Tree Protection Plan) and regular compliance inspections should be carried out to ensure trees root zone is not being impacted by the proposed works and trunk protection works have been carried out
- 5.64 **Tree 20** (*Eucalyptus haemastoma* Scribbly Gum) is a tree in poor condition (Dead/Dying) Appendix 1 gives a description of the tree as per AS-4970-2009 Section 2. Appendix 4 gives the location of the tree on the property.
- 5.65 The tree will not be affected by the proposed development (See Appendix 6 Construction Impact Statement). The trees soil and hydrological environments

will not be affected by the proposed development. Appropriate tree management in this situation would be the preservation of the tree for development, for its removal because of its poor condition a separate application under Northern Beaches Council Tree Preservation Order would be required.

- 5.66 If the tree is to be preserved it should be managed as per appendix 7 (Tree Protection Plan) and regular compliance inspections should be carried out to ensure trees root zone is not being impacted by the proposed works and trunk protection works have been carried out
- 5.67 **Tree 21** (*Eucalyptus haemastoma* Scribbly Gum) is a tree in poor condition (Dead/Dying) Appendix 1 gives a description of the tree as per AS-4970-2009 Section 2. Appendix 4 gives the location of the tree on the property.
- 5.68 The tree will not be affected by the proposed development (See Appendix 6 Construction Impact Statement). The trees soil and hydrological environments will not be affected by the proposed development. Appropriate tree management in this situation would be the preservation of the tree for development, for its removal because of its poor condition a separate application under Northern Beaches Council Tree Preservation Order would be required.
- 5.69 If the tree is to be preserved it should be managed as per appendix 7 (Tree Protection Plan) and regular compliance inspections should be carried out to ensure trees root zone is not being impacted by the proposed works and trunk protection works have been carried out
- 5.70 **Tree 22** (*Banksia serrata* Old Man Banksia) is a tree in fair condition Appendix 1 gives a description of the tree as per AS-4970-2009 Section 2. Appendix 4 gives the location of the tree on the property.
- 5.71 The tree will not be affected by the proposed development (See Appendix 6 Construction Impact Statement). The trees soil and hydrological environments will not be affected by the proposed development. Appropriate tree management in this situation would be the preservation of the tree
- 5.72 The tree should be managed as per appendix 7 (Tree Protection Plan) and regular compliance inspections should be carried out to ensure trees root zone is not being impacted by the proposed works and trunk protection works have been carried out
- 5.73 **Tree 23** (*Jacaranda mimosifolia* Jacaranda) is a tree in fair condition Appendix 1 gives a description of the tree as per AS-4970-2009 Section 2. Appendix 4 gives the location of the tree on the property.
- 5.74 The tree will not be affected by the proposed development (See Appendix 6 Construction Impact Statement). The trees soil and hydrological environments will not be affected by the proposed development. Appropriate tree management in this situation would be the preservation of the tree

- 5.75 The tree should be managed as per appendix 7 (Tree Protection Plan) and regular compliance inspections should be carried out to ensure trees root zone is not being impacted by the proposed works and trunk protection works have been carried out

6. Overall Recommendations from Arboricultural assessment and Development impact Statements

- 6.1 Trees 6, 7, 8, 9, 10 and 14 will be impacted by the proposed development and mitigation works as suggested above should be carried out as demonstrated in plans in Appendix 4.
- 6.2 That tree works are to be carried out, by a suitably qualified arborist with adequate Public Liability Coverage. The Tree Contractors Association of NSW recommends 20 Million Dollars coverage.
- 6.3 The remaining trees on the site should be protected as per Appendix 7 Tree Management Plan for this report.

7. Analyse of Plans

The plans propose the construction of a new sub division on the site and the construction of a new driveway See Attachment 4

The plans from an arboricultural point of view will significantly impact on the trees root zones of trees 6, 7, 8, 9 and 14 and will require the removal of the trees to carry out the proposed construction works.

The remaining trees will require protection as per the Tree Management Plan for the site in Appendix 7

8. Assessment of Impact of Development on Trees

Tree 1 will not be affected by the proposed works as can be seen from the plans in Appendix 4 of this report.

Tree 2 will not be affected by the proposed works as can be seen from the plans in Appendix 4 of this report.

Tree 3 will not be affected by the proposed works as can be seen from the plans in Appendix 4 of this report

Tree 4 will not be affected by the proposed works as can be seen from the plans in Appendix 4 of this report

Tree 5 will be affected by the proposed works as can be seen

from the plans in Appendix 4 of this report

Tree 6 will be affected by the proposed works as can be seen from the plans in Appendix 4 of this report

Tree 7 will be affected by the proposed works as can be seen from the plans in Appendix 4 of this report

Tree 8 will be affected by the proposed works as can be seen from the plans in Appendix 4 of this report

Tree 9 will be affected by the proposed works as can be seen from the plans in Appendix 4 of this report

Tree 10 will be affected by the proposed works as can be seen from the plans in Appendix 4 of this report

Tree 11 will not be affected by the proposed works as can be seen from the plans in Appendix 4 of this report

Tree 12 will not be affected by the proposed works as can be seen from the plans in Appendix 4 of this report

Tree 13 will not be affected by the proposed works as can be seen from the plans in Appendix 4 of this report

Tree 14 will be affected by the proposed works as can be seen from the plans in Appendix 4 of this report

Tree 15 will not be affected by the proposed works as can be seen from the plans in Appendix 4 of this report

Tree 16 will not be affected by the proposed works as can be seen from the plans in Appendix 4 of this report

Tree 17 will not be affected by the proposed works as can be seen from the plans in Appendix 4 of this report

Tree 18 will not be affected by the proposed works as can be seen from the plans in Appendix 4 of this report

Tree 19 will not be affected by the proposed works as can be seen from the plans in Appendix 4 of this report

Tree 20 will not be affected by the proposed works as can be seen from the plans in Appendix 4 of this report

Tree 21 will not be affected by the proposed works as can be seen from the plans in Appendix 4 of this report

Tree 22 will not be affected by the proposed works as can be seen

from the plans in Appendix 4 of this report

Tree 23 will not be affected by the proposed works as can be seen from the plans in Appendix 4 of this report

Mark Bury Principal Consultant

Mark Bury Consulting

Appendix 1 - Tree Schedule

Tree Number	1
Species	<i>Eucalyptus microcorys</i> Street Tree
Common Name	Tallowood
Vigour	Low vigour- Reduced ability of a tree to sustain its life processors. This may be evident by the a typical growth of leaves, reduced crown cover and reduced crown density, branches, roots and trunk, and a deterioration of their function with reduced resistance to predation. This is independent of the condition of a tree but may impact upon it , and especially the ability of a tree to sustain itself against predation
Structure	Poor Condition- Tree is of good habit or misshapen, a form that may be severely restricted for space and light , exhibits symptoms of advanced and irreversible decline such as fungal or bacterial infestation, major dieback in the branch and Foilage crown , structural deterioration from insect damage . Deterioration physically often characterised by a gradual and continuous reduction on vigour but maybe I dependant of a change in vigour but characterised by a proportionate increase in susceptibility to and predation by pests and diseases against which the tree cannot be sustained. Such conditions may also be evident in trees of advanced senescence due to normal phenological processors, without modifications to the growing environment or physical damage having been inflicted upon the tree. This may be dependant from or contributed to by vigour
Height (M)	15
Crown Spread and (M)	
Diameter at Brest Height (MM)	2590
Tree Root Zone (M)	15
Diameter at Base Height (MM)	2670
Structural Root Zone (M)	4.9
Gradient of Proposed Impact	Development <10 % Low Level of Impact acceptable with a 1 metre incursion into TPZ, it's a low level of impact on the TPZ of tree, Significance for Visual Effects -Medium Small. Significance Matrix for effects on Landscape Character and Features- Large Local See Appendix 6
Age Class	Mature- Tree aged 20-80% of life expectancy
Estimated Life Expectancy Sule Landscape Significance Overall Significance See Attachment 3	3b- Trees that may live for more than 15 years but would be removed for safety or nuisance reasons. Overall Significance. Medium –Tree Not Suitable for Preservation See Appendix 3 SULE and Significance of a Tree Assessment Rating System IACA Australia SULE and Significance of a Tree Assessment Rating System IACA Australia
Heritage/Cultural	Tree does not have a Heritage or Cultural Significance
Ecological and Habitat Matters	Tree has no Ecological or Habitat matters
Location to Site Features	The tree will not be required to be removed for the development to be constructed on the site,
Tree Issues	The tree has a very poor structure for the species.

Tree Number	2
Species	<i>Angophora costata</i> Street Tree
Common Name	Sydney Red Gum
Vigour	Low vigour- Reduced ability of a tree to sustain its life processors. This may be evident by the a typical growth of leaves, reduced crown cover and reduced crown density, branches, roots and trunk, and a deterioration of their function with reduced resistance to predation. This is independent of the condition of a tree but may impact upon it , and especially the ability of a tree to sustain itself against predation
Structure	Poor Condition- Tree is of good habit or misshapen, a form that may be severely restricted for space and light , exhibits symptoms of advanced and irreversible decline such as fungal or bacterial infestation, major dieback in the branch and Foilage crown , structural deterioration from insect damage . Deterioration physically often characterised by a gradual and continuous reduction on vigour but maybe I dependant of a change in vigour but characterised by a proportionate increase in susceptibility to and predation by pests and diseases against which the tree cannot be sustained. Such conditions may also be evident in trees of advanced senescence due to normal phenological processors, without modifications to the growing environment or physical damage having been inflicted upon the tree. This may be dependant from or contributed to by vigour
Height (M)	10
Crown Spread and (M)	8
Diameter at Brest Height (MM) Tree Root Zone (M)	350 4.2
Diameter at Base Height (MM) Structural Root Zone (M)	380 2.2
Gradient of Proposed Impact	Development <10 % Low Level of Impact acceptable with a 1 metre incursion into TPZ, it's a low level of impact on the TPZ of tree, Significance for Visual Effects - Small Small. Significance Matrix for effects on Landscape Character and Features- Small Local See Appendix 6
Age Class	Mature- Tree aged 20-80% of life expectancy
Estimated Life Expectancy Sule Landscape Significance Overall Significance See Attachment 3	3b- Trees that may live for more than 15 years but would be removed for safety or nuisance reasons. Overall Significance. Medium –Tree Not Suitable for Preservation See Appendix 3 SULE and Significance of a Tree Assessment Rating System IACA Australia SULE and Significance of a Tree Assessment Rating System IACA Australia
Heritage/Cultural	Tree does not have a Heritage or Cultural Significance
Ecological and Habitat Matters	Tree has no Ecological or Habitat matters
Location to Site Features	The tree will not be required to be removed for the development to be constructed on the site,
Tree Issues	The tree appears to be in decline as it has a large amount of dieback in the crown. The tree was a poor selection for the site given its ultimate generic dimensions The tree has been pollarded

Tree Number	3
Species	<i>Ficus rubignosa</i>
Common Name	Port Jackson Fig Tree
Vigour	Normal Vigour- Ability of a tree to maintain and sustain its life processes. This may be evident by the typical growth of leaves, crown cover and crown density, branches, roots and trunk and resistance to predation. This is independent of the condition of a tree but may impact upon it , and especially the ability of a tree but may impact upon it , and especially the ability of a tree to sustain itself against predation
Structure	Fair Condition - tree is of good habit or misshapen, a form not severely restricted for space and light has some physical indication of decline due to the early effects of predation by pests and diseases, fungal, bacterial, or insect infestation, or has suffered physical injury to itself that may be contributing to instability or structural weaknesses, or its basic survival. Such a tree may recover with remedial works where appropriate, or without intervention may stabilise or improve over time where appropriate, or without intervention may stabilise or improve over time, or in response to the implementation of beneficial changes to its local environment. This may be independent from, or contributed to by vigour.
Height (M)	15
Crown Spread and (M)	15
Diameter at Brest Height (MM) Tree Root Zone (M)	990 11.9
Diameter at Base Height (MM) Structural Root Zone (M)	1250 3.6
Gradient of Proposed Impact	Development <10 % Low Level of Impact acceptable with a 2 metre incursion into TPZ, it's a low level of impact on the TPZ of tree, Significance for Visual Effects – Large Small. Significance Matrix for effects on Landscape Character and Features- Large Local See Appendix 6
Age Class	Mature- Tree aged 20-80% of life expectancy
Estimated Life Expectancy Sule Landscape Significance Overall Significance See Attachment 3	3b- Trees that may live for more than 15 years but would be removed for safety or nuisance reasons. Overall Significance. Medium –Tree Suitable for Preservation See Appendix 3 SULE and Significance of a Tree Assessment Rating System IACA Australia SULE and Significance of a Tree Assessment Rating System IACA Australia
Heritage/Cultural	Tree does not have a Heritage or Cultural Significance
Ecological and Habitat Matters	Tree has no Ecological or Habitat matters
Location to Site Features	The tree will not be required to be removed for the development to be constructed on the site,
Tree Issues	Not Applicable

Tree Number	4
Species	<i>Eucalyptus microcorys</i>
Common Name	Tallowood
Vigour	Normal Vigour- Ability of a tree to maintain and sustain its life processes. This may be evident by the typical growth of leaves, crown cover and crown density, branches, roots and trunk and resistance to predation. This is independent of the condition of a tree but may impact upon it , and especially the ability of a tree but may impact upon it , and especially the ability of a tree to sustain itself against predation
Structure	Fair Condition - tree is of good habit or misshapen, a form not severely restricted for space and light has some physical indication of decline due to the early effects of predation by pests and diseases, fungal, bacterial, or insect infestation, or has suffered physical injury to itself that may be contributing to instability or structural weaknesses, or its basic survival. Such a tree may recover with remedial works where appropriate, or without intervention may stabilise or improve over time where appropriate, or without intervention may stabilise or improve over time, or in response to the implementation of beneficial changes to its local environment. This may be independent from, or contributed to by vigour.
Height (M)	15
Crown Spread and (M)	10
Diameter at Brest Height (MM) Tree Root Zone (M)	330 4
Diameter at Base Height (MM) Structural Root Zone (M)	580 2.6
Gradient of Proposed Impact	Development <10 % Low Level of Impact acceptable with a 2 metre incursion into TPZ, it's a low level of impact on the TPZ of tree, Significance for Visual Effects - Small Small. Significance Matrix for effects on Landscape Character and Features- Small Local See Appendix 6
Age Class	Mature- Tree aged 20-80% of life expectancy
Estimated Life Expectancy Sule Landscape Significance Overall Significance See Attachment 3	3b- Trees that may live for more than 15 years but would be removed for safety or nuisance reasons. Overall Significance. Medium –Tree Not Suitable for Preservation See Appendix 3 SULE and Significance of a Tree Assessment Rating System IACA Australia SULE and Significance of a Tree Assessment Rating System IACA Australia
Heritage/Cultural	Tree does not have a Heritage or Cultural Significance
Ecological and Habitat Matters	Tree has no Ecological or Habitat matters
Location to Site Features	The tree will not be required to be removed for the development to be constructed on the site,
Tree Issues	Not Applicable

Tree Number	5
Species	<i>Eucalyptus saligna</i>
Common Name	Sydney Blue Gum
Vigour	Normal Vigour- Ability of a tree to maintain and sustain its life processes. This may be evident by the typical growth of leaves, crown cover and crown density, branches, roots and trunk and resistance to predation. This is independent of the condition of a tree but may impact upon it , and especially the ability of a tree but may impact upon it , and especially the ability of a tree to sustain itself against predation
Structure	Fair Condition - tree is of good habit or misshapen, a form not severely restricted for space and light has some physical indication of decline due to the early effects of predation by pests and diseases, fungal, bacterial, or insect infestation, or has suffered physical injury to itself that may be contributing to instability or structural weaknesses, or its basic survival. Such a tree may recover with remedial works where appropriate, or without intervention may stabilise or improve over time where appropriate, or without intervention may stabilise or improve over time, or in response to the implementation of beneficial changes to its local environment. This may be independent from, or contributed to by vigour.
Height (M)	15
Crown Spread and (M)	10
Diameter at Brest Height (MM) Tree Root Zone (M)	810 9.7
Diameter at Base Height (MM) Structural Root Zone (M)	850 3.1
Gradient of Proposed Impact	Development 50 % High Level of Impact unacceptable with a 9 metre incursion into TPZ, it's a low level of impact on the TPZ of tree, Significance for Visual Effects -Medium Small. Significance Matrix for effects on Landscape Character and Features- Medium Local See Appendix 6
Age Class	Mature- Tree aged 20-80% of life expectancy
Estimated Life Expectancy Sule Landscape Significance Overall Significance See Attachment 3	3b- Trees that may live for more than 15 years but would be removed for safety or nuisance reasons. Overall Significance. Medium –Tree not Suitable for Preservation See Appendix 3 SULE and Significance of a Tree Assessment Rating System IACA Australia SULE and Significance of a Tree Assessment Rating System IACA Australia
Heritage/Cultural	Tree does not have a Heritage or Cultural Significance
Ecological and Habitat Matters	Tree has no Ecological or Habitat matters
Location to Site Features	The tree will be required to be removed for the development to be constructed on the site,
Tree Issues	Not Applicable

Tree Number	6
Species	<i>Eucalyptus microcorys</i>
Common Name	Tallowood
Vigour	Low vigour- Reduced ability of a tree to sustain its life processors. This may be evident by the a typical growth of leaves, reduced crown cover and reduced crown density, branches, roots and trunk, and a deterioration of their function with reduced resistance to predation. This is independent of the condition of a tree but may impact upon it , and especially the ability of a tree to sustain itself against predation
Structure	Poor Condition- Tree is of good habit or misshapen, a form that may be severely restricted for space and light , exhibits symptoms of advanced and irreversible decline such as fungal or bacterial infestation, major dieback in the branch and Foilage crown , structural deterioration from insect damage . Deterioration physically often characterised by a gradual and continuous reduction on vigour but maybe I dependant of a change in vigour but characterised by a proportionate increase in susceptibility to and predation by pests and diseases against which the tree cannot be sustained. Such conditions may also be evident in trees of advanced senescence due to normal phenological processors, without modifications to the growing environment or physical damage having been inflicted upon the tree. This may be dependant from or contributed to by vigour
Height (M)	15
Crown Spread and (M)	15
Diameter at Brest Height (MM) Tree Root Zone (M)	810 9.7
Diameter at Base Height (MM) Structural Root Zone (M)	730 2.9
Gradient of Proposed Impact	Development 50 % Significant Level of Impact Unacceptable with a 9.7 metre incursion into TPZ, it's a Significant level of impact on the TPZ of tree, Significance for Visual Effects - Medium Small. Significance Matrix for effects on Landscape Character and Features- Medium Local See Appendix 6
Age Class	Mature- Tree aged 20-80% of life expectancy
Estimated Life Expectancy Sule Landscape Significance Overall Significance See Attachment 3	3b- Trees that may live for more than 15 years but would be removed for safety or nuisance reasons. Overall Significance. Medium –Tree Not Suitable for Preservation See Appendix 3 SULE and Significance of a Tree Assessment Rating System IACA Australia SULE and Significance of a Tree Assessment Rating System IACA Australia
Heritage/Cultural	Tree does not have a Heritage or Cultural Significance
Ecological and Habitat Matters	Tree has no Ecological or Habitat matters
Location to Site Features	The tree will be required to be removed for the development to be constructed on the site,
Tree Issues	The tree appears to be in decline as it has a large amount of dieback in the crown. The tree was a poor selection for the site given its ultimate generic dimensions The tree has been pollarded

Tree Number	7
Species	<i>Eucalyptus microcorys</i>
Common Name	Tallowood
Vigour	Low vigour- Reduced ability of a tree to sustain its life processors. This may be evident by the a typical growth of leaves, reduced crown cover and reduced crown density, branches, roots and trunk, and a deterioration of their function with reduced resistance to predation. This is independent of the condition of a tree but may impact upon it , and especially the ability of a tree to sustain itself against predation
Structure	Poor Condition- Tree is of good habit or misshapen, a form that may be severely restricted for space and light , exhibits symptoms of advanced and irreversible decline such as fungal or bacterial infestation, major dieback in the branch and Foilage crown , structural deterioration from insect damage . Deterioration physically often characterised by a gradual and continuous reduction on vigour but maybe I dependant of a change in vigour but characterised by a proportionate increase in susceptibility to and predation by pests and diseases against which the tree cannot be sustained. Such conditions may also be evident in trees of advanced senescence due to normal phenological processors, without modifications to the growing environment or physical damage having been inflicted upon the tree. This may be dependant from or contributed to by vigour
Height (M)	18
Crown Spread and (M)	15
Diameter at Brest Height (MM) Tree Root Zone (M)	650 7.8
Diameter at Base Height (MM) Structural Root Zone (M)	930 3.2
Gradient of Proposed Impact	Development 50 % Significant Level of Impact Unacceptable with a 7.8 metre incursion into TPZ, it's a Significant level of impact on the TPZ of tree, Significance for Visual Effects - Medium Small. Significance Matrix for effects on Landscape Character and Features- Medium Local See Appendix 6
Age Class	Mature- Tree aged 20-80% of life expectancy
Estimated Life Expectancy Sule Landscape Significance Overall Significance See Attachment 3	3b- Trees that may live for more than 15 years but would be removed for safety or nuisance reasons. Overall Significance. Medium –Tree Not Suitable for Preservation See Appendix 3 SULE and Significance of a Tree Assessment Rating System IACA Australia SULE and Significance of a Tree Assessment Rating System IACA Australia
Heritage/Cultural	Tree does not have a Heritage or Cultural Significance
Ecological and Habitat Matters	Tree has no Ecological or Habitat matters
Location to Site Features	The tree will be required to be removed for the development to be constructed on the site,
Tree Issues	The tree appears to be in decline as it has a large amount of dieback in the crown. The tree was a poor selection for the site given its ultimate generic dimensions The tree has been pollarded

Tree Number	8
Species	<i>Eucalyptus microcorys</i>
Common Name	Tallowood
Vigour	Low vigour- Reduced ability of a tree to sustain its life processors. This may be evident by the a typical growth of leaves, reduced crown cover and reduced crown density, branches, roots and trunk, and a deterioration of their function with reduced resistance to predation. This is independent of the condition of a tree but may impact upon it , and especially the ability of a tree to sustain itself against predation
Structure	Poor Condition- Tree is of good habit or misshapen, a form that may be severely restricted for space and light , exhibits symptoms of advanced and irreversible decline such as fungal or bacterial infestation, major dieback in the branch and Foilage crown , structural deterioration from insect damage . Deterioration physically often characterised by a gradual and continuous reduction on vigour but maybe I dependant of a change in vigour but characterised by a proportionate increase in susceptibility to and predation by pests and diseases against which the tree cannot be sustained. Such conditions may also be evident in trees of advanced senescence due to normal phenological processors, without modifications to the growing environment or physical damage having been inflicted upon the tree. This may be dependant from or contributed to by vigour
Height (M)	8
Crown Spread and (M)	8
Diameter at Brest Height (MM) Tree Root Zone (M)	410 4.8
Diameter at Base Height (MM) Structural Root Zone (M)	610 7.3
Gradient of Proposed Impact	Development <10 % Low Level of Impact acceptable with a 2 metre incursion into TPZ, it's a low level of impact on the TPZ of tree, Significance for Visual Effects - Small Small. Significance Matrix for effects on Landscape Character and Features- Small Local See Appendix 6
Age Class	Mature- Tree aged 20-80% of life expectancy
Estimated Life Expectancy Sule Landscape Significance Overall Significance See Attachment 3	3b- Trees that may live for more than 15 years but would be removed for safety or nuisance reasons. Overall Significance. Medium –Tree Not Suitable for Preservation See Appendix 3 SULE and Significance of a Tree Assessment Rating System IACA Australia SULE and Significance of a Tree Assessment Rating System IACA Australia
Heritage/Cultural	Tree does not have a Heritage or Cultural Significance
Ecological and Habitat Matters	Tree has no Ecological or Habitat matters
Location to Site Features	The tree will be required to be removed for the development to be constructed on the site,
Tree Issues	The tree appears to be in decline as it has a large amount of dieback in the crown. The tree was a poor selection for the site given its ultimate generic dimensions The tree has been pollarded

Tree Number	9
Species	<i>Liquidamber styraciflua</i>
Common Name	Liquidambar
Vigour	Low vigour- Reduced ability of a tree to sustain its life processors. This may be evident by the a typical growth of leaves, reduced crown cover and reduced crown density, branches, roots and trunk, and a deterioration of their function with reduced resistance to predation. This is independent of the condition of a tree but may impact upon it , and especially the ability of a tree to sustain itself against predation
Structure	Poor Condition- Tree is of good habit or misshapen, a form that may be severely restricted for space and light , exhibits symptoms of advanced and irreversible decline such as fungal or bacterial infestation, major dieback in the branch and Foilage crown , structural deterioration from insect damage . Deterioration physically often characterised by a gradual and continuous reduction on vigour but maybe I dependant of a change in vigour but characterised by a proportionate increase in susceptibility to and predation by pests and diseases against which the tree cannot be sustained. Such conditions may also be evident in trees of advanced senescence due to normal phenological processors, without modifications to the growing environment or physical damage having been inflicted upon the tree. This may be dependant from or contributed to by vigour
Height (M)	18
Crown Spread and (M)	15
Diameter at Brest Height (MM) Tree Root Zone (M)	650 7.8
Diameter at Base Height (MM) Structural Root Zone (M)	930 3.2
Gradient of Proposed Impact	Development 50 % Significant Level of Impact Unacceptable with a 7.8 metre incursion into TPZ, it's a Significant level of impact on the TPZ of tree, Significance for Visual Effects - Medium Small. Significance Matrix for effects on Landscape Character and Features- Medium Local See Appendix 6
Age Class	Mature- Tree aged 20-80% of life expectancy
Estimated Life Expectancy Sule Landscape Significance Overall Significance See Attachment 3	3b- Trees that may live for more than 15 years but would be removed for safety or nuisance reasons. Overall Significance. Medium –Tree Not Suitable for Preservation See Appendix 3 SULE and Significance of a Tree Assessment Rating System IACA Australia SULE and Significance of a Tree Assessment Rating System IACA Australia
Heritage/Cultural	Tree does not have a Heritage or Cultural Significance
Ecological and Habitat Matters	Tree has no Ecological or Habitat matters
Location to Site Features	The tree will be required to be removed for the development to be constructed on the site,
Tree Issues	The tree appears to be in decline as it has a large amount of dieback in the crown. The tree was a poor selection for the site given its ultimate generic dimensions The tree has been pollarded

Tree Number	10
Species	<i>Eucalyptus microcorys</i>
Common Name	Tallowood
Vigour	Low vigour- Reduced ability of a tree to sustain its life processors. This may be evident by the a typical growth of leaves, reduced crown cover and reduced crown density, branches, roots and trunk, and a deterioration of their function with reduced resistance to predation. This is independent of the condition of a tree but may impact upon it , and especially the ability of a tree to sustain itself against predation
Structure	Poor Condition- Tree is of good habit or misshapen, a form that may be severely restricted for space and light , exhibits symptoms of advanced and irreversible decline such as fungal or bacterial infestation, major dieback in the branch and Foliage crown , structural deterioration from insect damage . Deterioration physically often characterised by a gradual and continuous reduction on vigour but maybe I dependant of a change in vigour but characterised by a proportionate increase in susceptibility to and predation by pests and diseases against which the tree cannot be sustained. Such conditions may also be evident in trees of advanced senescence due to normal phenological processors, without modifications to the growing environment or physical damage having been inflicted upon the tree. This may be dependant from or contributed to by vigour
Height (M)	12
Crown Spread and (M)	10
Diameter at Brest Height (MM) Tree Root Zone (M)	300 3.6
Diameter at Base Height (MM) Structural Root Zone (M)	810 3
Gradient of Proposed Impact	Development 50 % Significant Level of Impact Unacceptable with a 3.6 metre incursion into TPZ, it's a Significant level of impact on the TPZ of tree, Significance for Visual Effects - Medium Small. Significance Matrix for effects on Landscape Character and Features- Medium Local See Appendix 6
Age Class	Mature- Tree aged 20-80% of life expectancy
Estimated Life Expectancy Sule Landscape Significance Overall Significance See Attachment 3	3b- Trees that may live for more than 15 years but would be removed for safety or nuisance reasons. Overall Significance. Medium –Tree Not Suitable for Preservation See Appendix 3 SULE and Significance of a Tree Assessment Rating System IACA Australia SULE and Significance of a Tree Assessment Rating System IACA Australia
Heritage/Cultural	Tree does not have a Heritage or Cultural Significance
Ecological and Habitat Matters	Tree has no Ecological or Habitat matters
Location to Site Features	The tree will be required to be removed for the development to be constructed on the site,
Tree Issues	The tree appears to be in decline as it has a large amount of dieback in the crown. The tree was a poor selection for the site given its ultimate generic dimensions The tree has been pollarded

Tree Number	11
Species	<i>Corimbya gummifera</i>
Common Name	Red Bloodwood
Vigour	Normal Vigour- Ability of a tree to maintain and sustain its life processes. This may be evident by the typical growth of leaves, crown cover and crown density, branches, roots and trunk and resistance to predation. This is independent of the condition of a tree but may impact upon it , and especially the ability of a tree but may impact upon it , and especially the ability of a tree to sustain itself against predation
Structure	Fair Condition - tree is of good habit or misshapen, a form not severely restricted for space and light has some physical indication of decline due to the early effects of predation by pests and diseases, fungal, bacterial, or insect infestation, or has suffered physical injury to itself that may be contributing to instability or structural weaknesses, or its basic survival. Such a tree may recover with remedial works where appropriate, or without intervention may stabilise or improve over time where appropriate, or without intervention may stabilise or improve over time, or in response to the implementation of beneficial changes to its local environment. This may be independent from, or contributed to by vigour.
Height (M)	10
Crown Spread and (M)	6
Diameter at Brest Height (MM) Tree Root Zone (M)	450 5.4
Diameter at Base Height (MM) Structural Root Zone (M)	620 2.7
Gradient of Proposed Impact	Development <10 % Low Level of Impact acceptable with a 1 metre incursion into TPZ, it's a low level of impact on the TPZ of tree, Significance for Visual Effects - Small Small. Significance Matrix for effects on Landscape Character and Features- Small Local See Appendix 6
Age Class	Mature- Tree aged 20-80% of life expectancy
Estimated Life Expectancy Sule Landscape Significance Overall Significance See Attachment 3	3b- Trees that may live for more than 15 years but would be removed for safety or nuisance reasons. Overall Significance. Medium –Tree Suitable for Preservation See Appendix 3 SULE and Significance of a Tree Assessment Rating System IACA Australia SULE and Significance of a Tree Assessment Rating System IACA Australia
Heritage/Cultural	Tree does not have a Heritage or Cultural Significance
Ecological and Habitat Matters	Tree has no Ecological or Habitat matters
Location to Site Features	The tree will not be required to be removed for the development to be constructed on the site,
Tree Issues	Not Applicable

Tree Number	12
Species	<i>Lophostemon confertus</i>
Common Name	Brush Box
Vigour	Normal Vigour- Ability of a tree to maintain and sustain its life processes. This may be evident by the typical growth of leaves, crown cover and crown density, branches, roots and trunk and resistance to predation. This is independent of the condition of a tree but may impact upon it , and especially the ability of a tree but may impact upon it , and especially the ability of a tree to sustain itself against predation
Structure	Fair Condition - tree is of good habit or misshapen, a form not severely restricted for space and light has some physical indication of decline due to the early effects of predation by pests and diseases, fungal, bacterial, or insect infestation, or has suffered physical injury to itself that may be contributing to instability or structural weaknesses, or its basic survival. Such a tree may recover with remedial works where appropriate, or without intervention may stabilise or improve over time where appropriate, or without intervention may stabilise or improve over time, or in response to the implementation of beneficial changes to its local environment. This may be independent from, or contributed to by vigour.
Height (M)	10
Crown Spread and (M)	8
Diameter at Brest Height (MM)	210
Tree Root Zone (M)	2.5
Diameter at Base Height (MM)	280
Structural Root Zone (M)	1.9
Gradient of Proposed Impact	Development <10 % Low Level of Impact acceptable with a 1 metre incursion into TPZ, it's a low level of impact on the TPZ of tree, Significance for Visual Effects - Small Small. Significance Matrix for effects on Landscape Character and Features- Small Local See Appendix 6
Age Class	Mature- Tree aged 20-80% of life expectancy
Estimated Life Expectancy Sule Landscape Significance Overall Significance See Attachment 3	3b- Trees that may live for more than 15 years but would be removed for safety or nuisance reasons. Overall Significance. Medium –Tree Suitable for Preservation See Appendix 3 SULE and Significance of a Tree Assessment Rating System IACA Australia SULE and Significance of a Tree Assessment Rating System IACA Australia
Heritage/Cultural	Tree does not have a Heritage or Cultural Significance
Ecological and Habitat Matters	Tree has no Ecological or Habitat matters
Location to Site Features	The tree will not be required to be removed for the development to be constructed on the site,
Tree Issues	Not Applicable

Tree Number	13
Species	<i>Ficus rubignosa</i>
Common Name	Port Jackson Fig Tree
Vigour	Normal Vigour- Ability of a tree to maintain and sustain its life processes. This may be evident by the typical growth of leaves, crown cover and crown density, branches, roots and trunk and resistance to predation. This is independent of the condition of a tree but may impact upon it , and especially the ability of a tree but may impact upon it , and especially the ability of a tree to sustain itself against predation
Structure	Fair Condition - tree is of good habit or misshapen, a form not severely restricted for space and light has some physical indication of decline due to the early effects of predation by pests and diseases, fungal, bacterial, or insect infestation, or has suffered physical injury to itself that may be contributing to instability or structural weaknesses, or its basic survival. Such a tree may recover with remedial works where appropriate, or without intervention may stabilise or improve over time where appropriate, or without intervention may stabilise or improve over time, or in response to the implementation of beneficial changes to its local environment. This may be independent from, or contributed to by vigour.
Height (M)	18
Crown Spread and (M)	18
Diameter at Brest Height (MM)	2150
Tree Root Zone (M)	15
Diameter at Base Height (MM)	2800
Structural Root Zone (M)	4.9
Gradient of Proposed Impact	Development <10 % Low Level of Impact acceptable with a 2 metre incursion into TPZ, it's a low level of impact on the TPZ of tree, Significance for Visual Effects - Large Small. Significance Matrix for effects on Landscape Character and Features- Large Local See Appendix 6
Age Class	Mature- Tree aged 20-80% of life expectancy
Estimated Life Expectancy Sule Landscape Significance Overall Significance See Attachment 3	3b- Trees that may live for more than 15 years but would be removed for safety or nuisance reasons. Overall Significance. Medium –Tree Suitable for Preservation See Appendix 3 SULE and Significance of a Tree Assessment Rating System IACA Australia SULE and Significance of a Tree Assessment Rating System IACA Australia
Heritage/Cultural	Tree does not have a Heritage or Cultural Significance
Ecological and Habitat Matters	Tree has no Ecological or Habitat matters
Location to Site Features	The tree will not be required to be removed for the development to be constructed on the site,
Tree Issues	Not Applicable

Tree Number	14
Species	<i>Eucalyptus paniculata</i>
Common Name	Grey Ironbark
Vigour	Normal Vigour- Ability of a tree to maintain and sustain its life processes. This may be evident by the typical growth of leaves, crown cover and crown density, branches, roots and trunk and resistance to predation. This is independent of the condition of a tree but may impact upon it , and especially the ability of a tree but may impact upon it , and especially the ability of a tree to sustain itself against predation
Structure	Fair Condition - tree is of good habit or misshapen, a form not severely restricted for space and light has some physical indication of decline due to the early effects of predation by pests and diseases, fungal, bacterial, or insect infestation, or has suffered physical injury to itself that may be contributing to instability or structural weaknesses, or its basic survival. Such a tree may recover with remedial works where appropriate, or without intervention may stabilise or improve over time where appropriate, or without intervention may stabilise or improve over time, or in response to the implementation of beneficial changes to its local environment. This may be independent from, or contributed to by vigour.
Height (M)	8
Crown Spread and (M)	5
Diameter at Brest Height (MM)	210
Tree Root Zone (M)	2.5
Diameter at Base Height (MM)	230
Structural Root Zone (M)	1.8
Gradient of Proposed Impact	Development 50 % Significant Level of Impact Unacceptable with a 3.6 metre incursion into TPZ, it's a Significant level of impact on the TPZ of tree, Significance for Visual Effects - Medium Small. Significance Matrix for effects on Landscape Character and Features- Medium Local See Appendix 6
Age Class	Mature- Tree aged 20-80% of life expectancy
Estimated Life Expectancy Sule Landscape Significance Overall Significance See Attachment 3	3b- Trees that may live for more than 15 years but would be removed for safety or nuisance reasons. Overall Significance. Medium –Tree Not Suitable for Preservation See Appendix 3 SULE and Significance of a Tree Assessment Rating System IACA Australia SULE and Significance of a Tree Assessment Rating System IACA Australia
Heritage/Cultural	Tree does not have a Heritage or Cultural Significance
Ecological and Habitat Matters	Tree has no Ecological or Habitat matters
Location to Site Features	The tree will be required to be removed for the development to be constructed on the site,
Tree Issues	N/A

Tree Number	15
Species	<i>Angophora costata</i>
Common Name	Sydney Red Gum
Vigour	Normal Vigour- Ability of a tree to maintain and sustain its life processes. This may be evident by the typical growth of leaves, crown cover and crown density, branches, roots and trunk and resistance to predation. This is independent of the condition of a tree but may impact upon it , and especially the ability of a tree but may impact upon it , and especially the ability of a tree to sustain itself against predation
Structure	Fair Condition - tree is of good habit or misshapen, a form not severely restricted for space and light has some physical indication of decline due to the early effects of predation by pests and diseases, fungal, bacterial, or insect infestation, or has suffered physical injury to itself that may be contributing to instability or structural weaknesses, or its basic survival. Such a tree may recover with remedial works where appropriate, or without intervention may stabilise or improve over time where appropriate, or without intervention may stabilise or improve over time, or in response to the implementation of beneficial changes to its local environment. This may be independent from, or contributed to by vigour.
Height (M)	10
Crown Spread and (M)	4
Diameter at Brest Height (MM) Tree Root Zone (M)	300 3.6
Diameter at Base Height (MM) Structural Root Zone (M)	300 3.6
Gradient of Proposed Impact	Development <10 % Low Level of Impact acceptable with a .5 metre incursion into TPZ, it's a low level of impact on the TPZ of tree, Significance for Visual Effects – Small Small. Significance Matrix for effects on Landscape Character and Features- Small Local See Appendix 6
Age Class	Mature- Tree aged 20-80% of life expectancy
Estimated Life Expectancy Sule Landscape Significance Overall Significance See Attachment 3	3b- Trees that may live for more than 15 years but would be removed for safety or nuisance reasons. Overall Significance. Medium –Tree Suitable for Preservation See Appendix 3 SULE and Significance of a Tree Assessment Rating System IACA Australia SULE and Significance of a Tree Assessment Rating System IACA Australia
Heritage/Cultural	Tree does not have a Heritage or Cultural Significance
Ecological and Habitat Matters	Tree has no Ecological or Habitat matters
Location to Site Features	The tree will not be required to be removed for the development to be constructed on the site,
Tree Issues	Not Applicable

Tree Number	16
Species	<i>Angophora costata</i>
Common Name	Sydney Red Gum
Vigour	Normal Vigour- Ability of a tree to maintain and sustain its life processes. This may be evident by the typical growth of leaves, crown cover and crown density, branches, roots and trunk and resistance to predation. This is independent of the condition of a tree but may impact upon it , and especially the ability of a tree but may impact upon it , and especially the ability of a tree to sustain itself against predation
Structure	Fair Condition - tree is of good habit or misshapen, a form not severely restricted for space and light has some physical indication of decline due to the early effects of predation by pests and diseases, fungal, bacterial, or insect infestation, or has suffered physical injury to itself that may be contributing to instability or structural weaknesses, or its basic survival. Such a tree may recover with remedial works where appropriate, or without intervention may stabilise or improve over time where appropriate, or without intervention may stabilise or improve over time, or in response to the implementation of beneficial changes to its local environment. This may be independent from, or contributed to by vigour.
Height (M)	21
Crown Spread and (M)	20
Diameter at Brest Height (MM)	1100
Tree Root Zone (M)	13.2
Diameter at Base Height (MM)	1290
Structural Root Zone (M)	3.7
Gradient of Proposed Impact	Development <10 % Low Level of Impact acceptable with a .5 metre incursion into TPZ, it's a low level of impact on the TPZ of tree, Significance for Visual Effects – Large Small. Significance Matrix for effects on Landscape Character and Features- Large Local See Appendix 6
Age Class	Mature- Tree aged 20-80% of life expectancy
Estimated Life Expectancy Sule Landscape Significance Overall Significance See Attachment 3	3b- Trees that may live for more than 15 years but would be removed for safety or nuisance reasons. Overall Significance. Medium –Tree Suitable for Preservation See Appendix 3 SULE and Significance of a Tree Assessment Rating System IACA Australia SULE and Significance of a Tree Assessment Rating System IACA Australia
Heritage/Cultural	Tree does not have a Heritage or Cultural Significance
Ecological and Habitat Matters	Tree has no Ecological or Habitat matters
Location to Site Features	The tree will not be required to be removed for the development to be constructed on the site,
Tree Issues	Not Applicable

Tree Number	17
Species	<i>Eucalyptus haemastoma</i>
Common Name	Scribbly Gum
Vigour	Low vigour- Reduced ability of a tree to sustain its life processors. This may be evident by the a typical growth of leaves, reduced crown cover and reduced crown density, branches, roots and trunk, and a deterioration of their function with reduced resistance to predation. This is independent of the condition of a tree but may impact upon it , and especially the ability of a tree to sustain itself against predation
Structure	Poor Condition- Tree is of good habit or misshapen, a form that may be severely restricted for space and light , exhibits symptoms of advanced and irreversible decline such as fungal or bacterial infestation, major dieback in the branch and Foilage crown , structural deterioration from insect damage . Deterioration physically often characterised by a gradual and continuous reduction on vigour but maybe I dependant of a change in vigour but characterised by a proportionate increase in susceptibility to and predation by pests and diseases against which the tree cannot be sustained. Such conditions may also be evident in trees of advanced senescence due to normal phenological processors, without modifications to the growing environment or physical damage having been inflicted upon the tree. This may be dependant from or contributed to by vigour
Height (M)	5
Crown Spread and (M)	5
Diameter at Brest Height (MM)	120
Tree Root Zone (M)	2
Diameter at Base Height (MM)	150
Structural Root Zone (M)	1.5
Gradient of Proposed Impact	Development <10 % Low Level of Impact acceptable with a .5 metre incursion into TPZ, it's a low level of impact on the TPZ of tree, Significance for Visual Effects - Small Small. Significance Matrix for effects on Landscape Character and Features- Small Local See Appendix 6
Age Class	Mature- Tree aged 20-80% of life expectancy
Estimated Life Expectancy Sule Landscape Significance Overall Significance See Attachment 3	3b- Trees that may live for more than 15 years but would be removed for safety or nuisance reasons. Overall Significance. Medium –Tree Not Suitable for Preservation See Appendix 3 SULE and Significance of a Tree Assessment Rating System IACA Australia SULE and Significance of a Tree Assessment Rating System IACA Australia
Heritage/Cultural	Tree does not have a Heritage or Cultural Significance
Ecological and Habitat Matters	Tree has no Ecological or Habitat matters
Location to Site Features	The tree will not be required to be removed for the development to be constructed on the site,
Tree Issues	The tree appears to be in decline as it has a large amount of dieback in the crown. The tree was a poor selection for the site given its ultimate generic dimensions The tree has been pollarded

Tree Number	18
Species	<i>Eucalyptus haemastoma</i>
Common Name	Scribbly Gum
Vigour	Low vigour- Reduced ability of a tree to sustain its life processors. This may be evident by the a typical growth of leaves, reduced crown cover and reduced crown density, branches, roots and trunk, and a deterioration of their function with reduced resistance to predation. This is independent of the condition of a tree but may impact upon it , and especially the ability of a tree to sustain itself against predation
Structure	Poor Condition- Tree is of good habit or misshapen, a form that may be severely restricted for space and light , exhibits symptoms of advanced and irreversible decline such as fungal or bacterial infestation, major dieback in the branch and Foilage crown , structural deterioration from insect damage . Deterioration physically often characterised by a gradual and continuous reduction on vigour but maybe I dependant of a change in vigour but characterised by a proportionate increase in susceptibility to and predation by pests and diseases against which the tree cannot be sustained. Such conditions may also be evident in trees of advanced senescence due to normal phenological processors, without modifications to the growing environment or physical damage having been inflicted upon the tree. This may be dependant from or contributed to by vigour
Height (M)	5
Crown Spread and (M)	5
Diameter at Brest Height (MM)	210
Tree Root Zone (M)	2.5
Diameter at Base Height (MM)	200
Structural Root Zone (M)	1.7
Gradient of Proposed Impact	Development <10 % Low Level of Impact acceptable with a .5 metre incursion into TPZ, it's a low level of impact on the TPZ of tree, Significance for Visual Effects - Small Small. Significance Matrix for effects on Landscape Character and Features- Small Local See Appendix 6
Age Class	Mature- Tree aged 20-80% of life expectancy
Estimated Life Expectancy Sule Landscape Significance Overall Significance See Attachment 3	3b- Trees that may live for more than 15 years but would be removed for safety or nuisance reasons. Overall Significance. Medium –Tree Not Suitable for Preservation See Appendix 3 SULE and Significance of a Tree Assessment Rating System IACA Australia SULE and Significance of a Tree Assessment Rating System IACA Australia
Heritage/Cultural	Tree does not have a Heritage or Cultural Significance
Ecological and Habitat Matters	Tree has no Ecological or Habitat matters
Location to Site Features	The tree will not be required to be removed for the development to be constructed on the site,
Tree Issues	The tree appears to be in decline as it has a large amount of dieback in the crown. The tree was a poor selection for the site given its ultimate generic dimensions The tree has been pollarded

Tree Number	19
Species	<i>Macadamia integrifolia</i>
Common Name	Macadamia
Vigour	Normal Vigour- Ability of a tree to maintain and sustain its life processes. This may be evident by the typical growth of leaves, crown cover and crown density, branches, roots and trunk and resistance to predation. This is independent of the condition of a tree but may impact upon it , and especially the ability of a tree but may impact upon it , and especially the ability of a tree to sustain itself against predation
Structure	Fair Condition - tree is of good habit or misshapen, a form not severely restricted for space and light has some physical indication of decline due to the early effects of predation by pests and diseases, fungal, bacterial, or insect infestation, or has suffered physical injury to itself that may be contributing to instability or structural weaknesses, or its basic survival. Such a tree may recover with remedial works where appropriate, or without intervention may stabilise or improve over time where appropriate, or without intervention may stabilise or improve over time, or in response to the implementation of beneficial changes to its local environment. This may be independent from, or contributed to by vigour.
Height (M)	5
Crown Spread and (M)	5
Diameter at Brest Height (MM)	200
Tree Root Zone (M)	2.4
Diameter at Base Height (MM)	200
Structural Root Zone (M)	1.7
Gradient of Proposed Impact	Development <10% Significant Level of Impact acceptable with a .5 metre incursion into TPZ, it's a low level of impact on the TPZ of tree, Significance for Visual Effects - Small Small. Significance Matrix for effects on Landscape Character and Features- Small Local See Appendix 6
Age Class	Mature- Tree aged 20-80% of life expectancy
Estimated Life Expectancy Sule Landscape Significance Overall Significance See Attachment 3	3b- Trees that may live for more than 15 years but would be removed for safety or nuisance reasons. Overall Significance. Medium –Tree Not Suitable for Preservation See Appendix 3 SULE and Significance of a Tree Assessment Rating System IACA Australia SULE and Significance of a Tree Assessment Rating System IACA Australia
Heritage/Cultural	Tree does not have a Heritage or Cultural Significance
Ecological and Habitat Matters	Tree has no Ecological or Habitat matters
Location to Site Features	The tree will not be required to be removed for the development to be constructed on the site,
Tree Issues	The tree appears to be in decline as it has a large amount of dieback in the crown. The tree was a poor selection for the site given its ultimate generic dimensions The tree has been pollarded

Tree Number	20
Species	<i>Eucalyptus haemastoma</i>
Common Name	Scribbly Gum
Vigour	Low vigour- Reduced ability of a tree to sustain its life processors. This may be evident by the a typical growth of leaves, reduced crown cover and reduced crown density, branches, roots and trunk, and a deterioration of their function with reduced resistance to predation. This is independent of the condition of a tree but may impact upon it , and especially the ability of a tree to sustain itself against predation
Structure	Poor Condition- Tree is of good habit or misshapen, a form that may be severely restricted for space and light , exhibits symptoms of advanced and irreversible decline such as fungal or bacterial infestation, major dieback in the branch and Foilage crown , structural deterioration from insect damage . Deterioration physically often characterised by a gradual and continuous reduction on vigour but maybe I dependant of a change in vigour but characterised by a proportionate increase in susceptibility to and predation by pests and diseases against which the tree cannot be sustained. Such conditions may also be evident in trees of advanced senescence due to normal phenological processors, without modifications to the growing environment or physical damage having been inflicted upon the tree. This may be dependant from or contributed to by vigour
Height (M)	5
Crown Spread and (M)	5
Diameter at Brest Height (MM)	100
Tree Root Zone (M)	2
Diameter at Base Height (MM)	100
Structural Root Zone (M)	1.5
Gradient of Proposed Impact	Development <10 % Low Level of Impact acceptable with a .5 metre incursion into TPZ, it's a low level of impact on the TPZ of tree, Significance for Visual Effects - Small Small. Significance Matrix for effects on Landscape Character and Features- Small Local See Appendix 6
Age Class	Mature- Tree aged 20-80% of life expectancy
Estimated Life Expectancy Sule Landscape Significance Overall Significance See Attachment 3	3b- Trees that may live for more than 15 years but would be removed for safety or nuisance reasons. Overall Significance. Medium –Tree Not Suitable for Preservation See Appendix 3 SULE and Significance of a Tree Assessment Rating System IACA Australia SULE and Significance of a Tree Assessment Rating System IACA Australia
Heritage/Cultural	Tree does not have a Heritage or Cultural Significance
Ecological and Habitat Matters	Tree has no Ecological or Habitat matters
Location to Site Features	The tree will not be required to be removed for the development to be constructed on the site,
Tree Issues	The tree appears to be in decline as it has a large amount of dieback in the crown. The tree was a poor selection for the site given its ultimate generic dimensions The tree has been pollarded

Tree Number	21
Species	<i>Eucalyptus haemastoma</i>
Common Name	Scribbly Gum
Vigour	Low vigour- Reduced ability of a tree to sustain its life processors. This may be evident by the a typical growth of leaves, reduced crown cover and reduced crown density, branches, roots and trunk, and a deterioration of their function with reduced resistance to predation. This is independent of the condition of a tree but may impact upon it , and especially the ability of a tree to sustain itself against predation
Structure	Poor Condition- Tree is of good habit or misshapen, a form that may be severely restricted for space and light , exhibits symptoms of advanced and irreversible decline such as fungal or bacterial infestation, major dieback in the branch and Foilage crown , structural deterioration from insect damage . Deterioration physically often characterised by a gradual and continuous reduction on vigour but maybe I dependant of a change in vigour but characterised by a proportionate increase in susceptibility to and predation by pests and diseases against which the tree cannot be sustained. Such conditions may also be evident in trees of advanced senescence due to normal phenological processors, without modifications to the growing environment or physical damage having been inflicted upon the tree. This may be dependant from or contributed to by vigour
Height (M)	5
Crown Spread and (M)	5
Diameter at Brest Height (MM)	100
Tree Root Zone (M)	2
Diameter at Base Height (MM)	100
Structural Root Zone (M)	1.5
Gradient of Proposed Impact	Development <10 % Low Level of Impact acceptable with a .5 metre incursion into TPZ, it's a low level of impact on the TPZ of tree, Significance for Visual Effects - Small Small. Significance Matrix for effects on Landscape Character and Features- Small Local See Appendix 6
Age Class	Mature- Tree aged 20-80% of life expectancy
Estimated Life Expectancy Sule Landscape Significance Overall Significance See Attachment 3	3b- Trees that may live for more than 15 years but would be removed for safety or nuisance reasons. Overall Significance. Medium –Tree Not Suitable for Preservation See Appendix 3 SULE and Significance of a Tree Assessment Rating System IACA Australia SULE and Significance of a Tree Assessment Rating System IACA Australia
Heritage/Cultural	Tree does not have a Heritage or Cultural Significance
Ecological and Habitat Matters	Tree has no Ecological or Habitat matters
Location to Site Features	The tree will not be required to be removed for the development to be constructed on the site,
Tree Issues	The tree appears to be in decline as it has a large amount of dieback in the crown. The tree was a poor selection for the site given its ultimate generic dimensions The tree has been pollarded

Tree Number	22
Species	<i>Banksia serrata</i>
Common Name	Old Man Banksia
Vigour	Low vigour- Reduced ability of a tree to sustain its life processors. This may be evident by the a typical growth of leaves, reduced crown cover and reduced crown density, branches, roots and trunk, and a deterioration of their function with reduced resistance to predation. This is independent of the condition of a tree but may impact upon it , and especially the ability of a tree to sustain itself against predation
Structure	Poor Condition- Tree is of good habit or misshapen, a form that may be severely restricted for space and light , exhibits symptoms of advanced and irreversible decline such as fungal or bacterial infestation, major dieback in the branch and Foilage crown , structural deterioration from insect damage . Deterioration physically often characterised by a gradual and continuous reduction on vigour but maybe I dependant of a change in vigour but characterised by a proportionate increase in susceptibility to and predation by pests and diseases against which the tree cannot be sustained. Such conditions may also be evident in trees of advanced senescence due to normal phenological processors, without modifications to the growing environment or physical damage having been inflicted upon the tree. This may be dependant from or contributed to by vigour
Height (M)	8
Crown Spread and (M)	3
Diameter at Brest Height (MM)	330
Tree Root Zone (M)	4
Diameter at Base Height (MM)	380
Structural Root Zone (M)	2.2
Gradient of Proposed Impact	Development <10 % Low Level of Impact acceptable with a .5 metre incursion into TPZ, it's a low level of impact on the TPZ of tree, Significance for Visual Effects - Small Small. Significance Matrix for effects on Landscape Character and Features- Small Local See Appendix 6
Age Class	Mature- Tree aged 20-80% of life expectancy
Estimated Life Expectancy Sule Landscape Significance Overall Significance See Attachment 3	3b- Trees that may live for more than 15 years but would be removed for safety or nuisance reasons. Overall Significance. Medium –Tree Not Suitable for Preservation See Appendix 3 SULE and Significance of a Tree Assessment Rating System IACA Australia SULE and Significance of a Tree Assessment Rating System IACA Australia
Heritage/Cultural	Tree does not have a Heritage or Cultural Significance
Ecological and Habitat Matters	Tree has no Ecological or Habitat matters
Location to Site Features	The tree will not be required to be removed for the development to be constructed on the site,
Tree Issues	The tree appears to be in decline as it has a large amount of dieback in the crown. The tree was a poor selection for the site given its ultimate generic dimensions The tree has been pollarded

Tree Number	23
Species	<i>Jacaranda mimosifolia</i> Street Tree
Common Name	Jacaranda
Vigour	Low vigour- Reduced ability of a tree to sustain its life processors. This may be evident by the a typical growth of leaves, reduced crown cover and reduced crown density, branches, roots and trunk, and a deterioration of their function with reduced resistance to predation. This is independent of the condition of a tree but may impact upon it , and especially the ability of a tree to sustain itself against predation
Structure	Poor Condition- Tree is of good habit or misshapen, a form that may be severely restricted for space and light , exhibits symptoms of advanced and irreversible decline such as fungal or bacterial infestation, major dieback in the branch and Foilage crown , structural deterioration from insect damage . Deterioration physically often characterised by a gradual and continuous reduction on vigour but maybe I dependant of a change in vigour but characterised by a proportionate increase in susceptibility to and predation by pests and diseases against which the tree cannot be sustained. Such conditions may also be evident in trees of advanced senescence due to normal phenological processors, without modifications to the growing environment or physical damage having been inflicted upon the tree. This may be dependant from or contributed to by vigour
Height (M)	5
Crown Spread and (M)	10
Diameter at Brest Height (MM)	310
Tree Root Zone (M)	3.7
Diameter at Base Height (MM)	480
Structural Root Zone (M)	2.4
Gradient of Proposed Impact	Development <10 % Low Level of Impact acceptable with a .5 metre incursion into TPZ, it's a low level of impact on the TPZ of tree, Significance for Visual Effects - Small Small. Significance Matrix for effects on Landscape Character and Features- Small Local See Appendix 6
Age Class	Mature- Tree aged 20-80% of life expectancy
Estimated Life Expectancy Sule Landscape Significance Overall Significance See Attachment 3	3b- Trees that may live for more than 15 years but would be removed for safety or nuisance reasons. Overall Significance. Medium –Tree Not Suitable for Preservation See Appendix 3 SULE and Significance of a Tree Assessment Rating System IACA Australia SULE and Significance of a Tree Assessment Rating System IACA Australia
Heritage/Cultural	Tree does not have a Heritage or Cultural Significance
Ecological and Habitat Matters	Tree has no Ecological or Habitat matters
Location to Site Features	The tree will not be required to be removed for the development to be constructed on the site,
Tree Issues	The tree appears to be in decline as it has a large amount of dieback in the crown. The tree was a poor selection for the site given its ultimate generic dimensions The tree has been pollarded

Tree Photos

Tree 1
Eucalyptus microcorys
Tallowood



Tree 2
Angophora costata
Sydney Red Gum



Tree 3
Ficus rubignosa
Port Jackson Fig



Tree 4
Eucalyptus microcorys
Tallowood



Tree 5
Eucalyptus saligna
Sydney Blue Gum



Tree 6
Eucalyptus microcorys
Tallowood



Tree 7
Eucalyptus microcorys
Tallowood



Tree 8
Eucalyptus microcorys
Tallowood



Tree 9
Liquidambar styraciflua
Liquidamber



Tree 10
Eucalyptus microcorys
Tallowood



Tree 11
Corimbya gummifera
Red Bloodwood



Tree 12
Lophostemon confertus
Brushbox



Tree 13
Ficus rubignosa
Port Jackson Fig



Tree 14
Eucalyptus paniculata
Grey Ironbark



Tree 15
Angophora costata
Sydney Red Gum



Tree 16
Angophora costata
Sydney Red Gum



Tree 17
Eucalyptus haemastoma
Scribbly Gum



Tree 18
Eucalyptus haemastoma
Scribbly Gum



Tree 19
Macadamia integrifolia
Macadamia Nut Tree



Tree 20
Eucalyptus haemastoma
Scribbly Gum



Tree 21
Eucalyptus haemastoma
Scribbly Gum

Eucalyptus haemastoma
Scribbly Gum



Tree 22
Banksia serrata
Old Man Banksia



Tree 23
Jacaranda mimosifolia
Jacaranda



Appendix 3 - SULE Safe Useful Life Expectancy (Barell 1995)

	1. Long	2. Medium	3. Short	4. Removal	5. Moved or replaced
	Trees that appeared to be retainable at the time of assessment for more than 40 years with an acceptable level of risk.	Trees that appeared to be retainable at the time of assessment for 15 - 40 years with an acceptable level of risk.	Trees that appeared to be retainable at the time of assessment for 5 - 15 years with an acceptable level of risk.	Trees that should be removed within the next 5 years	Trees, which can be reliably moved or replaced.
A	Structurally sound trees located in positions that can accommodate future growth.	Trees that may only live between 15 and 40 years.	Trees that may only live between 5 and 15 more years.	Dead, dying, suppressed or declining trees through disease or inhospitable conditions.	Small trees less than 5m in height.
B	Trees that could be made suitable for retention in the long term by remedial tree care.	Trees that may live for more than 40 years but would be removed for safety or nuisance reasons.	Trees that may live for more than 15 years but would be removed for safety or nuisance reasons.	Dangerous trees through instability or recent loss of adjacent trees.	Young trees less than 15 years old but over 5m in height.
C	Trees of special significance for historical, commemorative or rarity reasons that would warrant extraordinary efforts to secure their long-term retention.	Trees that may live for more than 40 years but would be removed to prevent interference with more suitable individuals or to provide space for new planting.	Trees that may live for more than 15 years but should be removed to prevent interference with more suitable individuals or to provide space for new planting.	Damaged trees through structural defects including cavities, decay, included bark, wounds or poor form.	Trees that have been pruned to artificially control growth.
D		Trees that could be made suitable for retention in the medium term by remedial tree care.	Trees that require substantial remedial tree care and are only suitable for retention in the short term.	Damaged trees that are clearly not safe to retain.	
E				Trees that may live for more than 5 years but should be removed to prevent interference with more suitable individuals or to provide space for new plantings.	
F				Trees that are damaging or may cause damage to existing structures within 5 years.	
G				Trees that will become dangerous after removal of other trees for reasons given in A) to F).	

Safe Use Life Expectancy (SULE)

SULE is the length of time an Arborist assesses an individual tree can be retained with an acceptable level of risk based on the information available at the time of inspection. SULE is not static and is closely related to tree health and the surrounding conditions. Alterations to the variables may result in changes in the SULE assessment. SULE may have to be reassessed if a significant amount of time passes from the initial inspection to the eventual development. Once a tree survey has been carried out (as described above) the Arborist would then estimate the remaining life expectancy. This can be difficult if it is not known how long a particular species may live for in a particular location, however, the exercise is very useful for categorising which trees have the best chance of long term survival once construction is completed.

Categories for retention or removal.

The trees in each category could be colour coded both on site plans and on the ground. These categories are adapted and modified from BS5837:1991 and Barrell.

Category A:

Trees whose retention is most desirable; long safe useful life expectancy - retainable with an acceptable level of risk for more than 40 years+. Long category SULE.

- (i) Structurally sound trees of good form in positions that are compatible with the proposed development and where future growth can be accommodated.
- (ii) Trees for screening or softening the effect of existing structures in the near vicinity, or of particular visual importance to the locality.
- (iii) Trees of special significance for historical, commemorative or rarity reasons that would warrant extraordinary efforts to secure their long term retention.

Category B:

Trees whose retention is desirable or that would be retainable with an acceptable level of risk for 15-40 years. Moderate category: Medium category SULE.

- (i) Trees that may only live for another 15-40 years.
- (ii) Trees that may live for more than 40 years but which have defects which may lead to their removal within this period.
- (iii) Trees which may live more than 40 years but which would be removed to allow the safe development of more suitable individuals.
- (iv) Storm damaged or defective trees which can be made suitable for retention in the medium term by remedial treatment.
- (v) Immature trees with potential to develop into the high category.

Category C:

Trees that could be retained or those with an acceptable level of risk for 5-15 years. Short category SULE.

- (i) Trees that may only live for 5-15 years.
- (ii) Trees that may live for more than 15 years but which have defects that would lead to their removal within this period.
- (iii) Trees that may live for more than 15 years but which would be removed to allow the safe development of more suitable individuals.
- (iv) Damaged or defective trees which warrant remedial work for their short term retention.
- (v) Immature trees of no particular merit.

Category D:

Trees to be removed. Removal category SULE.

- (i) Dead trees.
- (ii) Unstable or structurally defective trees with a high hazard rating.
- (iii) Trees which will be impossible to retain or irreparably damaged by construction activities where no realistic compromise is possible.

Trees can be coded in reports and on site plans e.g. Tree 15. *Ficus rubiginosa* Category B (ii).

Note: These assessments should be carried out by a suitable qualified and experienced Arborist. (Judy Fakes, 1996)

Survey:

Peter Castor and John Douglas have both made the point that some species deteriorate more quickly than others. That is, a SULE rating of 5-15 years might not be sensible for a species such as *Eucalyptus scoparia* which might only have a useful life of some 2 years from when it first shows signs of deterioration. *Eucalyptus nicholii* in Sydney might also fit into this category. Perhaps it is sensible to recommend the removal of a Chilean Willow as soon as it first displays borer damage. It would not be sensible to apply that standard to a *Eucalyptus saligna* (Sydney Blue Gum)

Safe Useful Lifespans

Depending on the pattern of decline (a distinction needs to be drawn between biological life and useful life).

<i>Acacia elata</i>	30-50, decline rapidly if lopped
<i>Acacia parramattensis / decurrens</i>	5-15 years
<i>Acacia binervia (glaucescens) (Costal Myall)</i>	30 – 50
<i>Acacia melanoxylon</i>	50-90 years
<i>Acer negundo</i>	30-50
<i>Acmena smithii</i>	40-70
<i>Agonis flexuosa</i>	30-50
<i>Angophora costata</i>	70-90 (400+ in the bush)
<i>Banksia integrifolia</i>	50-60
<i>Banksia serrata</i>	20-30
<i>Bauhinia galpini</i>	30-50
<i>Betula pendula</i>	7-15
<i>Brachychiton acerifolius</i>	50-70, 10 after lopping
<i>Callistemon viminalis</i>	25
<i>Calodendrum capense</i>	50-70
<i>Castanospermum australis</i>	70
<i>Celtis australis</i>	70
<i>Celtis occidentalis</i>	15
<i>Ceratopetalum gummiferum</i>	90 in the bush Rarely in gardens.
<i>Ceratopetalum apetalum</i>	20
<i>Cinnamomum camphora</i>	90
<i>Corimbya. maculata</i>	50-70
<i>Corimbya citriodora</i>	70-90
<i>Corimbya gummifera</i>	25, if in right location 50
<i>Corimbya. eximia</i>	25, if in right location 70
<i>Cupaniopsis anacardioides</i>	60
<i>Elaeocarpus reticulatus</i>	40
<i>Erythrina x sykesii</i>	15-60
<i>Erythrina crista-galli</i>	30-40
<i>Eucalyptus camaldulensis</i>	70-90
<i>Corimbya ficifolia</i>	15
<i>Eucalyptus globulus</i> subspecies <i>globulus</i>	15-35
<i>Eucalyptus globulus</i> subspecies <i>bicostata</i>	15.35
<i>Eucalyptus microcorys</i>	50-70
<i>Eucalyptus nicholii</i>	35 years
<i>Eucalyptus pilularis</i>	70-90 (100-200 In the bush)
<i>Eucalyptus saligna</i>	70-90 (100-200 In the bush)
<i>Eucalyptus tereticornis</i>	70-90 (150-200)
<i>Ficus macrophylla</i>	90-200
<i>Ficus microcarpa</i> var <i>hillii</i>	30-70 Plus
<i>Ficus rubiginosa</i>	70-200
<i>Fraxinus excelsior</i>	10-30

Ginkgo Biloba	10-30
Grevillea robusta	35 years, 50 occasionally
Jacaranda mimosifolia	50-70 Plus
Lagerstroemia indica	30-90
Lagunaria patersonia	30-90
Liquidambar styraciflua	30-90
Lophostemon confertus	70 plus
Magnolia grandiflora	70 plus
Melaleuca quinquenervia	70 plus
Melia azedarach	50
Metrosideros excelsior	5-30, 50
Michelia figo	10-20
Morus nigra	50
Olea africana	70
Pistacia chinensis	40
Pittosporum undulatum	25-50
Platanus x hybrida	90 plus
Populus nigra	40- 70 years
Prunus serratifolia	5-35 years
Pyrus calleryana	30-50
Quercus robur	70-160
Robinia pseudoacacia	25-50 years
Salix species	7 Chilean, 30-50 years babylonica, fragilis
Sapium sebiferum	Up to 60
Schinus areira	70
Stenocarpus sinuatus	50
Syncarpia glomulifera	90
Syzigium parvifolia	90
Ulmus	70
Virgilia hupehensis	7 years

References:

Barrell, J.D. (1993) Pre-planning Tree Surveys: Safe Useful Life expectancy in the Natural Progression. Arboricultural Journal 17:pp33-46

Barrell, J.D. (1995 Pre-development Tree Assessment in Trees and Building Sites, (Ed) G.W. Watson and D. Neely, International Society of Arboriculture, Savoy, Illinois.

British Standard 5837 (1991) Guide for Trees in relation to Construction, BSI.

Fakes J.A, (1996) Summary of SULE (unpublished)

Hewett P, (1996) Personal communication.

Matheny, N.P & Clark, J.R. (1994) A Photographic Guide to the evaluation of Hazard Trees in Urban Areas, 2nd edition, International Society of Arboriculture, Savoy, Illinois.

Appendix E - Significance of a Tree, Assessment Rating System

(STARS) IACA, Australia

1. High Significance in landscape

- The tree is in good condition and good vigour;
- The tree has a form typical for the species;
- The tree is a remnant or is a planted locally indigenous specimen and/or is rare or uncommon in the local area or of botanical interest or of substantial age;
- The tree is listed as a Heritage Item, Threatened Species or part of an Endangered ecological community or listed on Councils significant Tree Register;
- The tree is visually prominent and visible from a considerable distance when viewed from most directions within the landscape due to its size and scale and makes a positive contribution to the local amenity;
- The tree supports social and cultural sentiments or spiritual associations, reflected by the broader population or community group or has commemorative values;
- The tree's growth is unrestricted by above and below ground influences, supporting its ability to reach dimensions typical for the taxa in situ - tree is appropriate to the site conditions.

2. Medium Significance in landscape

- The tree is in fair-good condition and good or low vigour;
- The tree has form typical or atypical of the species;
- The tree is a planted locally indigenous or a common species with its taxa commonly planted in the local area
- The tree is visible from surrounding properties, although not visually prominent as partially obstructed by other vegetation or buildings when viewed from the street,
- The tree provides a fair contribution to the visual character and amenity of the local area,
- The tree's growth is moderately restricted by above or below ground influences, reducing its ability to reach dimensions typical for the taxa in situ.

3. Low Significance in landscape

- The tree is in fair-poor condition and good or low vigour;
- The tree has form atypical of the species;
- The tree is not visible or is partly visible from surrounding properties as obstructed by other vegetation or buildings,
- The tree provides a minor contribution or has a negative impact on the visual character and amenity of the local area,
- The tree is a young specimen which may or may not have reached dimension to be protected by local Tree Preservation orders or similar protection mechanisms and can easily be replaced with a suitable specimen,
- The tree's growth is severely restricted by above or below ground influences, unlikely to reach dimensions typical for the taxa in situ - tree is inappropriate to the site conditions,
- The tree is listed as exempt under the provisions of the local Council Tree Preservation Order or similar protection mechanisms,
- The tree has a wound or defect that has potential to become structurally unsound.
- Environmental Pest / Noxious Weed Species
- The tree is an Environmental Pest Species due to its invasiveness or poisonous/ allergenic properties,
- The tree is a declared noxious weed by legislation.
- Hazardous/Irreversible Decline
- The tree is structurally unsound and/or unstable and is considered potentially dangerous,
- The tree is dead, or is in irreversible decline, or has the potential to fail or collapse in full or part in the immediate to short term.

The tree is to have a minimum of three (3) criteria in a category to be classified in that group.

Note: The assessment criteria are for individual trees only, however, can be applied to a monocultural stand in its entirety e.g.

Significance of a Tree, Assessment Rating System cont.

Landscape Significance						
		1. High	2. Medium	3. Low		
		Significance in landscape			Environmental Pest / Noxious Weed Species	Hazardous / Irreversible Decline
Estimated Life Expectancy	1. Long >40 years					
	2. Medium 15-40 years					
	3. Short <1-15 years					
	Dead					
Legend For Matrix Assessment						
	<p>Priority for Retention (High) – These trees are considered important for retention and should be retained and protected. Design modification or re-location of building/s should be considered to accommodate the setbacks as prescribed by the Australian Standard AS4980 Protection of trees on development sites. Tree sensitive construction measures must be implemented e.g. pier and beam etc if works are to proceed within the Tree Protection Zone.</p>					
	<p>Consider for Retention (Medium) – These trees may be retained and protected. These are considered less critical; however their retention should remain priority with removal considered only if adversely affecting the proposed building/works and all other alternatives have been considered and exhausted.</p>					
	<p>Consider for Removal (Low) – These trees are not considered important for retention, nor require special works or design modification to be implemented for their retention.</p>					
	<p>Priority for Removal – These trees are considered hazardous, or in irreversible decline, or weeds and should be removed irrespective of development.</p>					

Appendix 4 - Overall Site Map and Tree Location and Proposed Development

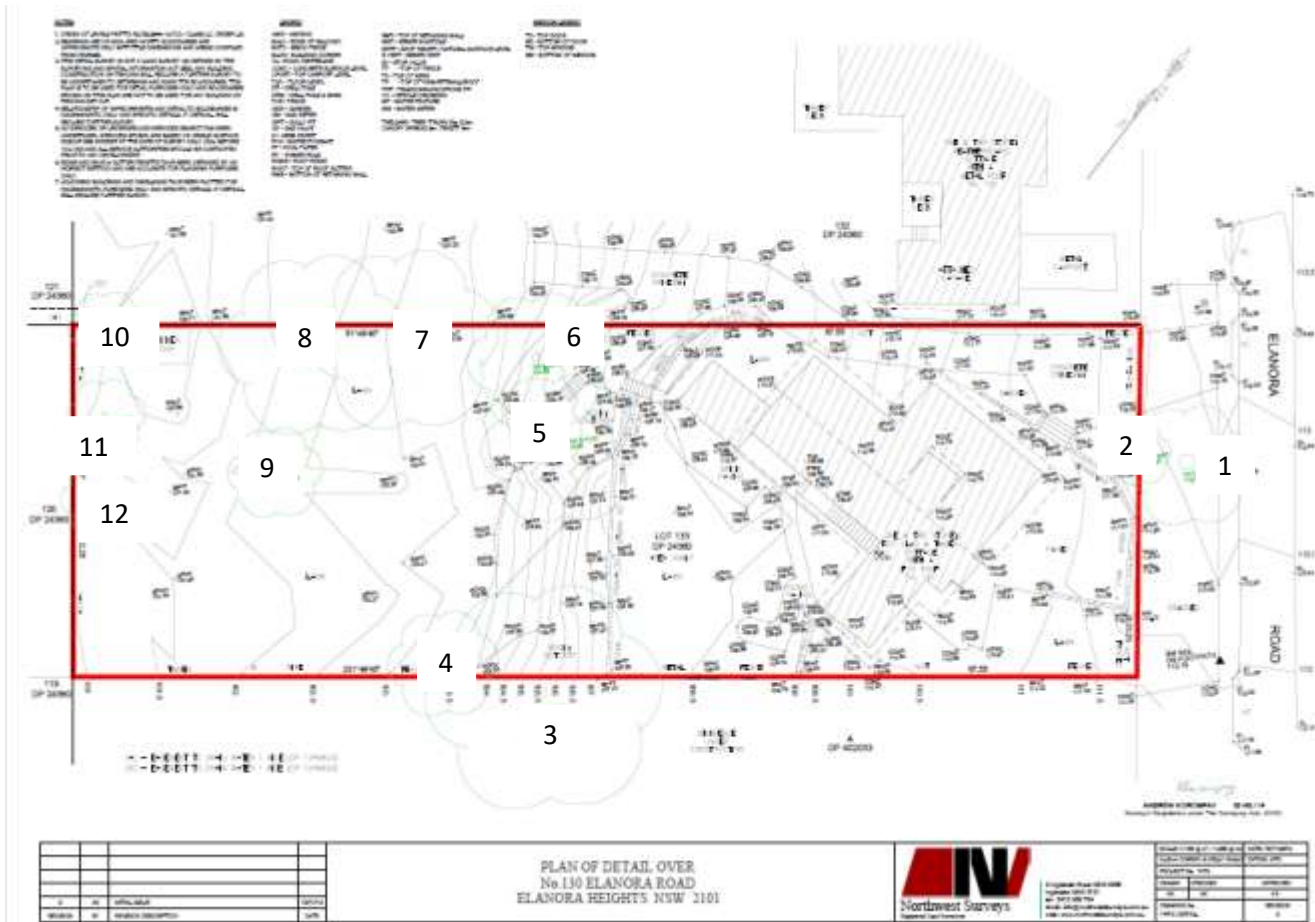

NOTES

1. This plan is a detail of the plan of the land shown in the plan of detail over No 132 Elanora Road, Elanora Heights NSW 2101.
2. The plan is a detail of the plan of the land shown in the plan of detail over No 132 Elanora Road, Elanora Heights NSW 2101.
3. The plan is a detail of the plan of the land shown in the plan of detail over No 132 Elanora Road, Elanora Heights NSW 2101.
4. The plan is a detail of the plan of the land shown in the plan of detail over No 132 Elanora Road, Elanora Heights NSW 2101.
5. The plan is a detail of the plan of the land shown in the plan of detail over No 132 Elanora Road, Elanora Heights NSW 2101.
6. The plan is a detail of the plan of the land shown in the plan of detail over No 132 Elanora Road, Elanora Heights NSW 2101.
7. The plan is a detail of the plan of the land shown in the plan of detail over No 132 Elanora Road, Elanora Heights NSW 2101.
8. The plan is a detail of the plan of the land shown in the plan of detail over No 132 Elanora Road, Elanora Heights NSW 2101.
9. The plan is a detail of the plan of the land shown in the plan of detail over No 132 Elanora Road, Elanora Heights NSW 2101.
10. The plan is a detail of the plan of the land shown in the plan of detail over No 132 Elanora Road, Elanora Heights NSW 2101.

LEGEND

1. 1:1000 Scale
 2. 1:1000 Scale
 3. 1:1000 Scale
 4. 1:1000 Scale
 5. 1:1000 Scale
 6. 1:1000 Scale
 7. 1:1000 Scale
 8. 1:1000 Scale
 9. 1:1000 Scale
 10. 1:1000 Scale

ABBREVIATIONS

1. 1:1000 Scale
 2. 1:1000 Scale
 3. 1:1000 Scale
 4. 1:1000 Scale
 5. 1:1000 Scale
 6. 1:1000 Scale
 7. 1:1000 Scale
 8. 1:1000 Scale
 9. 1:1000 Scale
 10. 1:1000 Scale

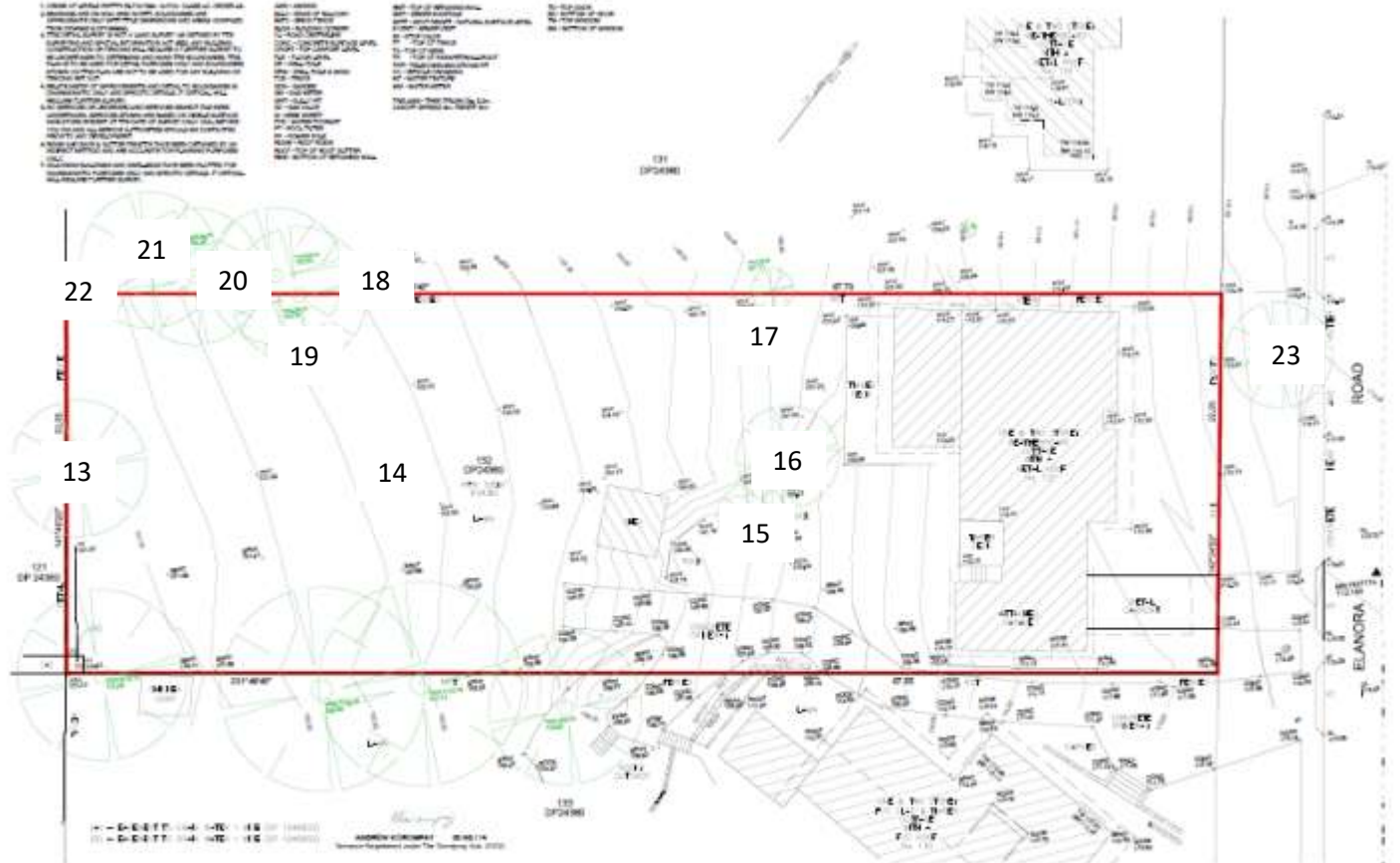

1	1:1000 Scale	1:1000 Scale
2	1:1000 Scale	1:1000 Scale
3	1:1000 Scale	1:1000 Scale
4	1:1000 Scale	1:1000 Scale
5	1:1000 Scale	1:1000 Scale
6	1:1000 Scale	1:1000 Scale
7	1:1000 Scale	1:1000 Scale
8	1:1000 Scale	1:1000 Scale
9	1:1000 Scale	1:1000 Scale
10	1:1000 Scale	1:1000 Scale

**PLAN OF DETAIL OVER
 No 132 ELANORA ROAD
 ELANORA HEIGHTS NSW 2101**



1	1:1000 Scale	1:1000 Scale
2	1:1000 Scale	1:1000 Scale
3	1:1000 Scale	1:1000 Scale
4	1:1000 Scale	1:1000 Scale
5	1:1000 Scale	1:1000 Scale
6	1:1000 Scale	1:1000 Scale
7	1:1000 Scale	1:1000 Scale
8	1:1000 Scale	1:1000 Scale
9	1:1000 Scale	1:1000 Scale
10	1:1000 Scale	1:1000 Scale

Appendix 5 - Brief Qualifications and Experience of Mark Bury

- 1. Qualifications:** Diploma of Horticulture/Arboriculture 2005, Advanced Certificate of Management 1995, Graduate Certificate in Parks Management UTS 2001. Advanced Certificate Horticulture TAFE 1986, Hadlington Certificate of Tree Care 1995 Licensed QTRA Practitioner since 2006. International Society of Arboriculture Tree Risk Assessment Qualification 2014, Completed refresher Course in 2018 and Licensed till 2024 International Society of Arboriculture Certified Arborist 2014 Licensed till 2020, International Society of Arboriculture Certified Municipal Specialist 2015 Licensed till 2020, currently studying International Society of Arboriculture Board Master Arborist Course
- 2. Practical experience:** Twenty Three (23) years experience as a consulting arborist, 20 years experience in Local Government as a consulting arborist. A Founding member of the Institute of Australian Consulting Arborist (Resigned 2006) and The Local Government Tree Resources Group which I was Secretary of in 1995.
- 3. Continuing professional development:** Member of International Society of Arboriculture (AU0345A). Member of Australian Institute of Horticulture (MXB0615), attended courses by Jeremy Barrell and Claus Matteck. I attended the update of QTRA certification March 2015 and completed course in Visual Tree Assessment in 2015 and Visual Tree Assessment and Estimating the probability of failure in 2015.
- 4. Relevant experience** Twenty Three (23) Years experience as a consulting arborist and Twenty years experience in tree management in local government. Twenty (20) years experience in Local Government assessing development applications in regards to tree management issues. (Councils; Warringah, North Sydney, Mosman, Manly, Ashfield, Pittwater, Marrickville and Hornsby).

With my qualifications and experience I am an AQF 5. Furthermore I have written and published books on Trees and Asset Management, Trees and Real Estate, Planning and Trees and Inherent Failure Patterns of Trees in the Greater Sydney Area.

I have also been a high Level Asset Manager in Local Government for 10 years and have carried out numerous courses in asset management and risk management and developed Council Budgets in this area for a number of years.

I also have lectured at UTS on Asset Management. I have worked in the Industry for 36 years and have carried out major Asset management inventories including trees for large Local Government Areas and developed financial and operations plans to manage assets. Furthermore I have developed, written and implemented asset tree master plans for Ashfield, Pittwater, Hornsby and Marrickville Councils.

International Society of Arboriculture Continuing Education Units Completed 2014, 2015 and 2016

Tree Risk-Strategies for Preserving Heritage Trees
Tree Risk-Mitigation and Reporting
Tree Risk-Structural Defects and Conditions
Tree Risk-Tree Load: Concept
Tree Risk—Loads and Growth Response
Tree Risk-Levels of Tree Risk Assessment
Tree Risk- Sap Rot
Tree Risk- Anchorage: Root Plate Resistance to Failure
Tree Risk- Indicators of Decay in Urban Trees
Tree Risk- Visual Inspection Prior to Dismantling
Urban Forestry-Wildfire and the Role of the Arborist
Urban Forestry-Managing Trees during Construction Part 1 and 2
Urban Forestry-Tree Risk Assessment: A Foundation
Urban Forestry-Tree Inventories Part 1 and Part 2
Trees & Their Environment- Fertilizing Trees & Shrubs Part 1 and Part 2
Urban Forestry-Root Management Challenges on Urban Sites
Urban Forestry-Challenges for the Built Environment
Urban Forestry - The Benefit of Trees
Urban Forestry- Root Planting Friendly Site Design
Urban Forestry- Root Management Challenges on Urban Sites
Urban Forestry- Tree Inventories Part 1
Urban Forestry- Tree Inventories Part 2
Urban Forestry- Tree Risk Assessment a Foundation
Urban Forestry- Managing Trees during Construction Parts 1 and 2
Urban Forestry- Wildfire and the Role of the Arborist
Trees & Their Environment- Soil Properties: Part 1 and Part 2
Trees & Their Environment- Fertilizing Trees & Shrubs Part 1 and Part 2
Trees & Their Environment- Analyse Before You Fertilize
Trees & Their Environment- Back to Basics: Tree Fertilization
Trees & Their Environment- Slow or Controlled Release Fertilizers
Tree Maintenance- Trees & Lightning
Tree Maintenance- Cabling
Tree Maintenance- Pollarding: What Was Old Is New Again
Tree Maintenance- Why Utilities "V-Out" Trees
Tree Maintenance- Pruning Trees Part 1: Principles, Objectives & Pruning Types
Tree Maintenance- Pruning Trees Part 2: How, Where and How Much
Plant Health Care- Plant Health Care
Plant Health Care- Maintaining Tree and Turf Associations
Plant Health Care- Preserving Trees during the Construction Process
Plant Health Care- Mulch
Plant Health Care- Preserving trees during the Construction Process
Plant Health Care- Trees v Turf
Plant Health Care- Resource Allocation Trade Off
Plant Health Care- Root System Care
Safe Working Practices –Innovations in Climbing Techniques and Equipment
Safe Working Practices- Basic Chain Saw Maintenance
Safe Working Practices- Felling Techniques
Safe Working Practices- Engineering Concepts for Arborists
Safe Working Practices- Tree Removals
Safe Working Practices- Chain Saw Cutting Techniques

Tree Science-Palms just not for the Tropics
 Tree Science-Damage and Diagnosis Steps to Proper Diagnosis
 Tree Science- Plant Traits that Resemble Abiotic Disorders
 Tree Science- Adventitious Roots Occurrence and Management in Trees
 Tree Science- Cool Trees Surviving Cold Temperatures
 Tree Science- Identifying Wood Decay and Wood Decay Fungi in Urban Trees
 Tree Science- How Pests use Bark or Wood as Food
 Tree Science- How trees get to fat
 Tree Science- Kissing under the Mistletoe
 Biology-Tree Failure Risk Evaluations
 Biology-Tree Growth Rings Formation and Form
 Biology- Regulating Tree Growth Keeping the Green Side Up
 Biology- How Wind Affects Trees
 Biology- Allelopathy in Trees
 Biology- Fantasy Facts and Fall Colour
 Biology- Blowing in the Wind
 Biology-Tree Physiology
 Biology-Basic Woody Plant Biology
 Diagnosis and Treatment- Plant Health Care and the Diagnostic Process
 Diagnosis and Treatment- Want to be a Better Plant Diagnostician
 Diagnosis and Treatment- Diagnosing Disease Problems on Trees
 Diagnosis and Treatment- How Weather Influences Insect and Mite Populations
 Diagnosis and Treatment- Understanding and Diagnosing Scale Insects
 Diagnosis and Treatment- Surefire Rules of Diagnosis
 Diagnosis and Treatment- Diagnosing Abiotic Disorders
 Tree Selection and Planting- A plant by any Other Name
 Tree Selection and Planting- Installation and Establishment of Trees and Shrubs
 Tree Selection and Planting- Ten Keys to Plant and Site Selection
 Tree Selection and Planting- Tree Transplanting
 Tree Selection and Planting- Tree Transplanting and Establishment
 Tree Selection and Planting- Post Planting Maintenance of Trees and Shrubs
 Tree Selection and Planting- Tree Trunk Protection
 Tree Selection and Planting- Siting Selecting and Planting Problems
 Tree Selection and Planting- Girdling Root Formation in Landscape Trees
 Tree Selection and Planting- Right Tree, Right Location
 Tree Selection and Planting- Dendrology and Taxonomy
 Tree and Development
 The Landscape below Ground
 General- Arborist Equipment Study Program

International Society of Arboriculture
Continuing Education Units Completed 2017

Root Pruning Part 2
 Palms: Woody Giants of the Monocots Part 2
 Biology and Assessment of Callus and Woundwood
 Managing Soils That Support Urban Trees Part 1
 Palms: Woody Giants of the Monocots Part 1
 Tree Injection Part 1
 Plant Health Care and Diagnostics
 Root Management: An Introduction
 Bark Traits are Important to Tree health and Survival
 The Cost of Not Maintaining the Urban Forest
 Flood Tolerant Trees in the Urban Sphere
 Integrated Vegetation Management
 Advanced Twig Anatomy
 Tree Lightning Protection Systems Part 2
 Tree Safety

Continuing Education Units Completed 2018

Managing Soils That Support Urban Trees Part Two
Preserving Trees During Construction
Arborists and Wildlife Retaining Trees for Wildlife Habitat
Understanding Tree Responses to Abiotic and Biotic Stress Complexes
Storm Response Part 1 Types of Storms and Their Effects on Trees
Storm Response Part 2 Preparing for Safe and Effective Responses to Storms
Storm Response Part 3 Effective Response to Large and Small –Scale Storm Emergencies
Storm Response Part 4 Unique Aspects :Keeping Employees Safe, Talking to the Media, Saving Damaged Trees, Winding Down, and Lessons Learned
Tree Inventories
Understanding Tree Responses to Stress
Tree Lightning Protection Systems (Part One)
Root Management Challenges on Urban Sites Achieving a Healthy Root Crown Balance
Root Management Challenges on Urban Sites Human Intervention in Root Development
Tree Risk Assessment Structural Defects and Conditions that Affect the Likelihood of Failure
Basic Tree Plumbing Translocation
Tree Injection (Part 2)
Advanced Twig Anatomy Starting Little to Get Big (Part 1)
Biology and Identification of Fungi
Urban Tree Inventory Data
Comparison of Tree Conditions
Roadside Soil Enhancement
Tree Species as Tools for Biodiversity and Phytoremediation
Homeowner Interactions with Residential Trees In Urban Areas
Does Modulus of Elasticity Vary
Long Term Fluctuations in Water Status and Crown Die Back
Maximum Size Expectations in Designed Space
The Arboricultural and Economic Benefits of Formative Pruning
Protecting Your Assets
The Management of Tree Roots in Urban and Suburban Settings
The Costs on Not Maintaining and Maintaining Urban Forest
Tree Performance during Early Years and Future Performance
Effects of Urbanisation on Tree Species Composition and Structure
Things Arborist Should Know about Soil Microbes
Wood Chips and Compost Improve Compacted Urban Soil
The Linear Index of Tree Appraisal Model
The Influence of Abiotic factors on street tree condition and mortality in a commercial retail Streetscape
Water Management Strategies in Dry Environments
Comparison of Shading Effectiveness
Vines and Utility Arboriculture
Vegetation and Storm Water Run Off

Appendix 6 - Construction Impact Specifications

(Trees that are less than 100mm in both Diameter at Breast Height and Diameter at Base Height)

3.2 DETERMINING THE TPZ

The radius of the TPZ is calculated for each tree by multiplying its DBH \times 12.

$$\text{TPZ} = \text{DBH} \times 12$$

where

DBH = trunk diameter measured at 1.4 m above ground

Radius is measured from the centre of the stem at ground level.

A TPZ should not be less than 2 m nor greater than 15 m (except where crown protection is required). Clause 3.3 covers variations to the TPZ.

The TPZ of palms, other monocots, cycads and tree ferns should not be less than 1 m outside the crown projection.

3.3 VARIATIONS TO THE TPZ

3.3.1 General

It may be possible to encroach into or make variations to the standard TPZ. Encroachment includes excavation, compacted fill and machine trenching.

3.3.2 Minor encroachment

If the proposed encroachment is less than 10% of the area of the TPZ and is outside the SRZ (see Clause 3.3.5), detailed root investigations should not be required. The area lost to this encroachment should be compensated for elsewhere and contiguous with the TPZ. Variations must be made by the project arborist considering relevant factors listed in Clause 3.3.4. The figures in Appendix D demonstrate some examples of possible encroachment into the TPZ up to 10% of the area.

3.3.3 Major encroachment

If the proposed encroachment is greater than 10% of the TPZ or inside the SRZ (see Clause 3.3.5), the project arborist must demonstrate that the tree(s) would remain viable. The area lost to this encroachment should be compensated for elsewhere and contiguous with the TPZ. This may require root investigation by non-destructive methods and consideration of relevant factors listed in Clause 3.3.4.

ENCROACHMENT INTO TREE PROTECTION ZONE

(Informative)

Encroachment into the tree protection zone (TPZ) is sometimes unavoidable. Figure D1 provides examples of TPZ encroachment by structures, to assist in reducing the impact of such incursions.

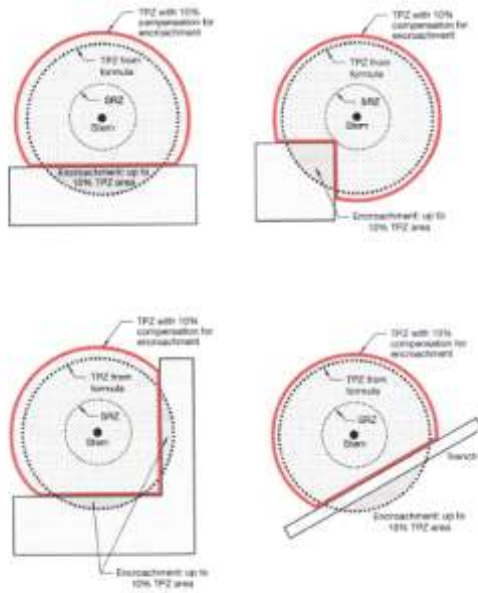

NOTE: Less than 10% TPZ area and inside TRZ. Any loss of TPZ compensated for elsewhere.

FIGURE D1 EXAMPLES OF MINOR ENCROACHMENT INTO TPZ

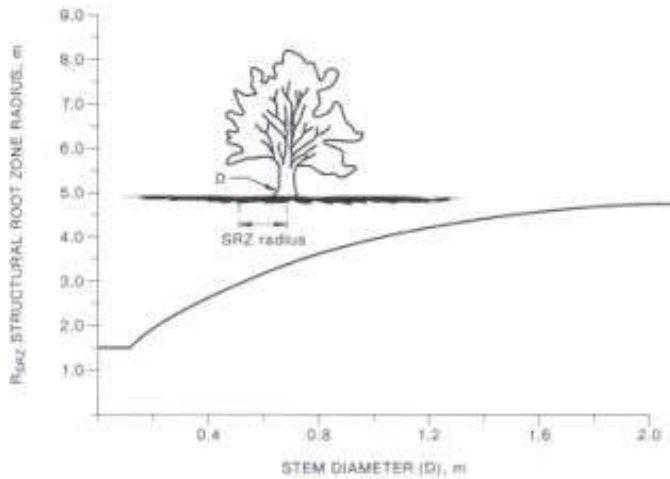

The curve can be expressed by the following formula:
 $R_{SRZ} = (D \times 50)^{0.42} \times 0.54$

NOTES:

1. R_{SRZ} is the structural root zone radius.
2. D is the stem diameter measured immediately above root buttress.
3. The SRZ for trees less than 0.15 m diameter is 1.5 m.
4. The SRZ formula and graph do not apply to palms, other monocots, cycads and tree ferns.
5. This does not apply to trees with an asymmetrical root plate.

FIGURE 1 STRUCTURAL ROOT ZONE

SIGNIFICANCE MATRIX FOR EFFECTS ON LANDSCAPE CHARACTER AND FEATURES

(Proprietors only, professional interpretation of individual office required)

Magnitude of Change lies along a continuum from very Large to none, with an overlap between each defined category. This is determined by assessing the extent of the changes, landscape type or feature affected within the context of the site and its performance of the intent.

Negligible / None		Small		Medium		Large		Very Large	
No discernible change to any landscape elements or character		A barely perceptible deterioration (or improvement) in elements or character		A noticeable deterioration (or improvement) in landscape character and landscape elements		A significant deterioration (or improvement) in landscape character or loss of features over an extensive area		A complete variance with the landscape goals and patterns of the landscape	
International	No effect	No effect	Substantial	Substantial	Substantial	Substantial	Substantial	Substantial	Substantial
County	No effect	Moderate	Moderate	Moderate	Moderate	Moderate	Moderate	Moderate	
									High (Local)
Moderate (Local)	No effect	Slight	Slight	Slight	Slight	Slight	Slight	Slight	
									Low (Local)

Intensity of Landscape Character and Landscape Features for being consistent depending on the items importance - from international to low local importance - with overlap between with different categories. The sensitivity of these depends upon the level of existing degradation within the item in quality and condition of the landscape character within the site.

SIGNIFICANCE MATRIX FOR VISUAL EFFECTS

(For guidance only, professional interpretation of individual effects is essential)

Magnitude of Change lies along a continuum from very large to none, with an overlap between each defined category. This will depend on the amount of a view affected, the number of viewers affected and the duration of the impact.

	Negligible / None <i>No discernible change in the view</i>	Small <i>A barely perceptible change in view</i>	Medium <i>A noticeably deteriorative (or improvement) in the view</i>	Large <i>Changes are visible and would significantly impact (or improve) views of the area</i>	Very Large <i>Proposals are highly visible disrupting views into and across the area</i>
Very High <i>Including views with internationally designated landscape (National Park, ACT/NT, the setting of an individual farm and Aboriginal or Torres Strait Heritage)</i>	No Effect	Medium	Substantial	Substantial	Substantial
High <i>Including views with significant rights of way, regional landscape of view, landscape or the setting of a Circle /P field buildings, towers and views from residential properties</i>	No Effect	High / Medium	Medium	Substantial	Substantial
Medium <i>Including views from people engaged in outdoor sports or recreation, including people walking over and those driving on local roads.</i>	No Effect	High	High / Medium	Medium	Substantial
Low <i>Keyhole view, major transport corridors.</i>	No Effect	High / Negligible	High	Medium	Medium
Negligible <i>Including people working remote for business and industry</i>	No Effect	Negligible	High	High	Medium

KOTIMULOORANG
CONSULTING AND DESIGN

Appendix 7 - Arboricultural Management Plan (Tree Protection Plan) for 130-132 Elanora Road Elanora Heights NSW

Contents

Pre Construction Inspection.....	63
Construction Procedure for Trees to be preserved	63
Pruning Specifications for Trees Recommended for Preservation	64
Construction Procedure for Trees during works.....	64
Construction Phase Monitoring.....	65
Post Construction Management.....	66

Pre Construction Inspection

The pre construction inspection will be carried out prior to the commencement of any excavation or building works on the proposed development site.

Compliance with the following items will be required before authorization to commence construction will be consented.

Construction Procedure for Trees to be preserved

1. Before beginning work, the contractor is required to meet with the consultant at the site to review all work procedures, access routes, storage areas, and tree protection measures.
2. Fences have been erected to protect tree to be preserved. Fences define a specific protection zone for the tree. Fences are to remain until all site work has been completed. Fences may not be relocated or removed without the written permission of the consultant.
3. Construction trailers and traffic and storage areas must remain outside fenced areas at all times.
4. All underground utilities and drain or irrigation lines shall be routed outside the tree protection zone. If lines must traverse the protection area, they shall be tunneled or bored under the tree. The site arborist should be present during any such works.
5. No materials, equipment, spoil, or waste or washout water may be deposited, stored, or parked within the tree protection zone (fenced area).
6. Additional tree pruning required for clearance during construction must be performed by a qualified arborist and not by construction personnel.
7. Any herbicides placed under paving materials must be safe for use around trees and labeled for that use. Any pesticides used on site must be tree-safe and not

easily transported by water.

Pruning Specifications for Trees Recommended for Preservation

1. All trees within the project area shall be pruned to:
 - a. Clear the crown of diseased, crossing, weak, and dead wood
 - b. Provide 5 metres of vertical clearance over streets and 3 metres over Sidewalks;
 - c. Remove stubs, cutting outside the wound wood tissue that has Formed around the branch;
 - d. Reduce end weight on heavy, horizontal branches by selectively removing small diameter branches, no greater than 50-100mm near the ends of the scaffolds.
2. Where temporary clearance is needed for access, branches shall be tied back to hold them out of the clearance zone. All pruning shall be performed by a qualified arborist with a minimum of 10 Million Dollars public liability insurance. That all tree pruning works are carried out as per the Australian Standard AS 4373-2007 Pruning of amenity trees and as per the Code of Practice Amenity Tree Industry August 1998. Interior branches shall not be stripped out.
3. Pruning cuts larger than 100mm in diameter, except for dead wood, shall be avoided.
4. Pruning cuts that expose heartwood shall be avoided whenever possible.
5. No more than 20 percent of live foliage shall be removed within the tree to be preserved.
6. While in the tree, the arborist shall perform and aerial inspection to identify defects that require treatment. Any additional work needed shall be reported to the consultant. The branches that require pruning have been identified and photographed on pages 14 and 20 of site photographs for the respective trees
7. Brush shall be chipped and chips shall be spread underneath trees within the tree protection zone to a maximum depth of 200mm, leaving the trunk clear of mulch.

Construction Procedure for Trees during works

1. The site arborist is to be present during any excavation works adjacent any trees on the site. This is required to specify and supervise any horticultural works that should be carried out to any nominated tree for retention.
2. If injury should occur to any tree during construction, it should be evaluated as soon as possible by the site arborist so that appropriate treatments can be applied.
3. Any grading, construction, demolition, or other work that is expected to encounter

- tree roots must be monitored by the consulting arborist.
4. The tree shall be irrigated on a schedule to be determined by the consultant. Each irrigation shall wet the soil within the tree protection zone to a depth of 100mm.
 5. Erosion control devices such as silt fencing, debris basins, and Water diversion structures shall be installed to prevent siltation and or erosion within the tree protection zone.
 6. Before grading, pad preparation, or excavation for foundations, footings, walls, or trenching, they shall be 300mm outside the tree protection zone by cutting all roots cleanly to a depth of 800mm. Roots shall be cut by manually digging a trench and cutting exposed roots with a saw, vibrating knife, rock saw, and narrow trencher with sharp blades, or other approved root-pruning equipment.
 7. Any roots damaged during grading or construction shall be exposed to sound tissue and cut cleanly with a saw.
 8. Spoil from trenches, basements, or other excavations shall not be placed within the tree protection zone either temporarily or permanently.
 9. No burn piles or debris pits shall be placed within the tree protection zone. No ashes, debris, or garbage maybe dumped or buried within the tree protection zone.
 10. Maintain fire-safe areas around fenced areas. Also, no heat sources, flames, Ignition sources or smoking is allowed near mulch or trees.

These inspections will be carried out on an as needed requirement. It recommended that all excavations near trees be carried out together to reduce costs for the client and that the site arborist is present to determine any root pruning treatments that might be required to be carried out at the time of excavation.

Construction Phase Monitoring

Fortnightly inspections will be required to observe six major areas during the construction phase.

- **Maintain the tree protection zone.** Maintaining the integrity of the tree protection zone is the single most important factor in protecting trees from excessive damage. Space often is at a premium on construction sites and the open areas denied by the tree protection zone are attractive locations for all types of activities that can cause damage to trees, including storing materials, Parking vehicles and dumping waste.
- **Assist with changes in the field.** Few projects proceed without changes in the field. This occurs for a variety of reasons. Plans and field situations may not match, and work must occur closer to the tree than planned. Alternatively, an item may have escaped notice or was not discovered until construction. The Consultant must participate in the decisions that could affect trees.

- **Monitor tree health and conditions and specifying appropriate treatments.** Sometimes, even with a comprehensive tree protection plan, trees are accidentally damaged. The consultant must be available to recommend mitigations and appropriate actions when damage has occurred. Similarly, changes in water status, pest populations, etc. must be identified early so treatments can be applied.
- **Communicate with the project superintendent and contractors.** In our experience, one of the most critical factors in the success of a tree preservation project is the commitment of the project superintendent who manages all on-site construction activity. The superintendent's interest and willingness to support tree preservation actions (for example, honouring the tree protection zone) is vital. The consultant must acknowledge the range of demands for time and money facing the superintendent in completing the project and establish an effective means of communication and cooperation at the site.
- **Help identify appropriate work procedures around trees.** The arborist should talk with the project superintendent and contractors to identify work Procedures that are effective for all parties and minimize impacts to trees. The Consultant can help identify locations for haul roads that avoid trees while providing adequate turn and back-up zones for equipment.
- **Facilitate completion of the project.** Once a project is approved and Construction begun, one of the consultant's responsibilities is to help complete the project in a timely manner. This is not done at the expense of adequate tree protection, but in a spirit of cooperation.

Post Construction Management

Tree Maintenance program: Care of trees following construction

The management of preserved trees following construction must encompass the needs of both individual trees and the forest remnants they comprise. The following Tree Maintenance areas will be inspected for compliance on an annual basis following the completion of works for 2 years.

Caring for Individual Trees

The program of post construction care for individual trees focuses on the normal goals of any tree management effort such as maintenance of vigour and structural stability. For trees to remain assets to the community, they must remain in good condition with low potential for failure. We address these goals by treating the tree itself (pruning, pest management) and the environment around the tree (mulch, irrigation). Overall, we strive to avoid any factors that predispose the tree to attack by pests and loss of wood through decay.

The most common remedial actions recommended for trees impacted by construction include the treatments described below.

Irrigation

Trees that have suffered loss of roots may not be able to exploit as large a soil volume as they did before injury. Alternatively, changed patterns of drainage across a site may divert water into new drainage patterns, away from trees. In either case, trees may benefit from supplemental irrigation. The following are general guidelines.

- The amount of water applied must be appropriate to the needs of the individual species.
- Light, frequent irrigations should be avoided. Irrigation should wet the entire root zone and be allowed to dry before another application.
- Excess irrigation from new landscapes should be avoided. Runoff from plantings should be minimized and/or directed away from trees.
- Wetting the trunk should be avoided.

Another approach is to reduce water loss by misting the canopy. In this technique, fine sprays of water are applied throughout the canopy on regular, relatively continuous intervals. The mist appears to raise humidity and reduce air temperature within the canopy, thereby reducing water loss. Shrader (1996) considered this treatment instrumental in the survival of transplanted oaks in Florida.

Pruning Specification further discussion

Trees on construction sites should be inspected annually to determine pruning requirements. Pruning may be required for one of two reasons. First, crowns may need to have dead, dying, diseased, broken, and otherwise structurally weak branches removed.

This pruning may also involve reducing the size of the crown where dieback is extensive. Second, crowns may be thinned to reduce the amount of canopy exposed to wind and to balance weight among branches.

Arborists have long debated the value of pruning the crown as a way of compensating for loss of roots; however, there is no scientific evidence to support this practice. Watson (1991) notes "... no research has been published to demonstrate the effectiveness (of crown reduction pruning) on mature trees." Harris (1992) notes, "As with most things, moderation would appear to be wise in caring for root-damaged trees."

Our recommendation is that arborists not attempt to balance root loss by reducing the size of the crown. Rather, we recommend that the health and structure of the tree be monitored and appropriate pruning actions be applied.

Where scaffolding is required it should be erected outside the TPZ. Where it is essential for scaffolding to be erected within the TPZ branch removal should be minimized. This can be achieved by designing scaffolding to avoid branches or tying back branches. Ground below the scaffolding should be protected by boarding (e.g. scaffolding board or plywood sheeting as shown). Where access is required a board walk or other surface material should be installed to minimise sheeting to prevent soil contamination. The boarding should be left in place until the scaffolding is removed.

- Notes:
- 1 For trunk and branch protection use boards and padding that will prevent damage to bark. Boards are to be strapped to trunks, not nailed or screwed.
 - 2 Rubble boards should be a suitable thickness to prevent soil compaction and root damage.
- (Excerpt from AS4970:2009)

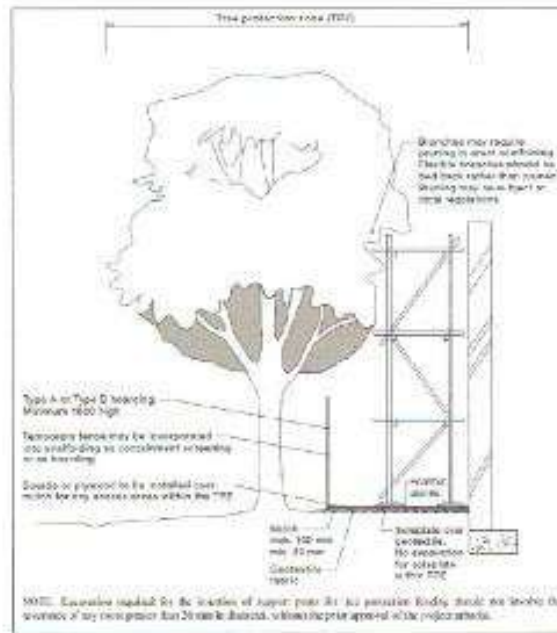

Mulch

Trees preserved on construction sites generally will benefit from having a 100- to -200 mm layer of organic mulch beneath the canopy. The mulch will reduce loss of moisture from the soil, protect against compaction, and moderate soil temperatures. It also has been demonstrated that the addition of mulch reduces soil compaction over time (see section on remedial soil treatment).

We normally specify that brush from pruning be chipped and spread under the crown. Mulch depth should be adjusted so that only 1 to 2 inches is placed against the trunk of the tree.

Fertilisation

Arborists are not in agreement about the value of supplemental fertilization to trees preserved on construction sites. A consistent benefit to such treatment has not been demonstrated by scientific research. Because trees growing in forests settings do not usually exhibit any symptoms of nutrient deficiency, we might surmise that mineral elements are not lacking in the soil and, therefore, supplementing those nutrients following root injury is not necessary. Although applications of supplemental fertilizer have resulted in increased growth of trees in forest stands, trees preserved on development sites are no longer strictly forest trees. Historical patterns of nutrient cycling are disrupted as soil, litter, and woody debris is removed; mycorrhizal associations are altered; and Patterns of water movement through the profile and across the site are changed. Moreover, we expect trees in landscape settings to be healthier than those in woodland environments.

In addition, there is significant anecdotal evidence regarding the benefits of supplemental fertilization. We assume that the ability of trees on construction sites to absorb water and mineral nutrients has been reduced due to injury and root compaction. Providing supplemental fertilization, therefore, allows the trees to absorb necessary elements with a limited root system. Trees that were previously growing in urban landscapes or without maintenance may benefit from fertilization.

Pest Management

Tree death often follows a pattern of weakening by predisposing stresses, such as injury from construction, followed by attack from opportunistic pests and pathogens. For example, the two lined chestnut borer attacks oak trees that have been weakened by biotic or environmental stress (Dunn et al. 1990). Oak trees that have been mechanically wounded are predisposed to attack by *Armillaria* (Svihra 1991). Construction activity has been associated with decline of white pine (Weaver and Stipes 1988) and with increased occurrence of oak wilt (Miller et al. 1993).

Pest Management is an important part of a post-construction maintenance program. Developing pest management programs for preserved trees involves:

- Knowledge of the tree species and its pattern(s) of decline and death
- Treating the tree to enhance vigour and/or avoid predisposition (e.g., Supplemental irrigation, timing of pruning)
- Monitoring for the presence of pests
- Applying preventive control treatments

Because trees impacted by construction are more susceptible to pests, managers need to be vigilant about pest management programs. Particular attention must be paid to monitoring for pest and to application of control procedures. Thresholds for treatment may be more conservative on infested trees than for undisturbed trees. Under normal circumstances, the action threshold for control procedures might be defoliation of 30 percent of the crown. For trees impacted by development activity, a threshold of 15 to 20 percent defoliation would be more appropriate.

Removing fill soil

In situations where grades have been raised within the dripline, the fill soil should be removed to original grade. If the entire root area cannot be cleared of fill, a minimum 1.5-foot radius around the trunk should be returned to natural grade. In some cases, a small retaining wall may be necessary. Drainage must be provided to ensure that water does not collect at the base of the trunk. Removal of fill soil should occur by hand, especially within 3 metres of the trunk.

Remediation of Soils Damaged During Construction

The structure of soils on development sites is often altered during the construction process. Soils are compacted to provide a stable base for structures, as vehicles move across the site, and when utilities and other improvements are installed. Miller (1996) noted, however, that “compaction” is often used as a catch-all term for soil disturbances including kneading, churning, rutting, and displacement. By whatever means it is accomplished, compaction results in increased soil density and decreased porosity. It is an unfavorable environment for roots as well as soil micro flora.

Consultants are frequently asked to recommend treatments that will quickly reduce compaction and improve structure. Rolf (1992a), Day and Bassuk (1994), and Smiley (1996) reviewed possible amelioration treatments. Solutions such as tillage and sub-soiling are not appropriate on development sites where large trees are already present. In post construction situations, four treatment options are available.

- Holes and fractures can be created to increase air space. This is accomplished by injecting high-pressure water or air and physically auguring openings. In some cases, voids are filled with porous material such as sand or gravel, a process known as vertical mulching.
- Soil is removed from radically oriented trenches and replaced with porous soil material. Removal may be achieved either by backhoe and other mechanical methods or by hydro excavation (Gross 1995).
- Organic mulch can be placed around the tree beneath the canopy.
- The tree can be treated with growth regulators such as paclobutrazol (Watson 1996).

The experimental results from examining the effectiveness of the numerous possible remediation treatments are ambiguous. However, three treatments appear to provide clear benefits. First, mulching the soil beneath the canopy with organic mulch is beneficial. Smiley (1996) notes “... the most dramatic results I have ever seen in a soil compaction experiment came from using mulch by itself.” Smiley (1996) also demonstrated improvements in trunk growth of Crepe Myrtle and Callery Pear trees in a compacted soil setting. Second, the soil removal and replacement technique has resulted in clear improvements in tree growth (Watson et al. 1996. Watson 1996, Smiley 1996). In Watson’s work, however, the soils involved were not described as compacted at the start of the project. Third, Watson (1996) demonstrated increased root development of declining white oak trees from application of paclobutrazol.

Other experiments using vertical mulching (drilling holes in the soil and filling them with mulch material) of all types, treatment with biostimulants, aeration, and other methods have yielded either inconsistent or negative results for either soil characteristics or tree health. The exception to this has been the work of Rolf (1992b and 1994), which focused on remediation treatments in improving growing conditions of new plantings. It is clear that prevention and avoidance are the key elements in dealing with soil compaction and related degradations in structure on development sites. Consultants have limited ability to provide effective long-lasting treatments. As Rolf (1992a) noted, “There are no perfect methods for aeration around trees in limited spaces and where vegetation is already established.”

Design and Documentation Considerations

Impacts to tree	Construction Activity	Methods/Treatments to minimise damage.
Root Loss	Stripping site of organic surface soil before grading; clearing unwanted vegetation; demolishing existing structures	<ul style="list-style-type: none"> • Restrict stripping of topsoil around trees • Install fences to protect trees from injury • Any woody vegetation to be removed adjacent to trees to remain should be cut at ground level and not pulled out by equipment; otherwise, root injury to remaining trees may result. Arborist may be needed for adjacent tree removal if crowns are intertwined.
	Lowering grade, scarifying, preparing sub grade for fill and structures	<ul style="list-style-type: none"> • Before grading, root prune tree at edge of excavation to depth required. • Spoil beyond cut face can be removed by equipment sitting outside the dripline of the tree • Use retaining walls with discontinuous footings to increase the distance that natural grade is maintained from trunk.
	Preparing sub grade for pavement	<ul style="list-style-type: none"> • Use paving section requiring a minimum amount of excavation (e.g., reinforced concrete instead of asphalt). • To minimize thickness of pavement section, design, traffic patterns to avoid heavy loads adjacent to trees. • Increase strength of pavement to reduce reliance on sub grade for strength (e.g., use extra reinforcement in concrete, geotextile under base material).

Impacts to tree	Construction Activity	Methods/Treatments to minimise damage.
	Excavations for footings, walls , foundations	<ul style="list-style-type: none"> • Avoid continuous footings adjacent to trees • Use pier foundations with grade beam above grade instead of slab foundations • Orient piers to avoid major roots. • Excavate by hand, bridging roots where possible. • Where roots must be removed, cut cleanly with appropriate equipment (e.g. rock saw). Do not use equipment that pulls and shatters roots (eg. Backhoe, trencher).
	Trenching for utilities, drains	<ul style="list-style-type: none"> • Where roots must be removed, cut cleanly with appropriate equipment (e.g. rock saw). Do not use equipment that pulls and shatters roots (eg. Backhoe, trencher). * Avoid open trenching in root area * Tunnel under roots, if possible. * If not, within root area, dig trench by hand, bridging roots greater than 250mm diameter. Consolidate utilities into one trench.
Wounding crown of tree	Injury from equipment	<ul style="list-style-type: none"> • Fence trees to enclose low branches and protect trunk. • Clean up wounds as soon as possible • Prune to minimum height required prior to construction.

Impacts to tree	Construction Activity	Methods/Treatments to minimise damage.
	Creating clearance for building, traffic, construction equipment	<ul style="list-style-type: none"> • Consider minimum height requirements of construction equipment and emergency vehicles over roads. • All pruning should be performed by a Certified arborist and conform to ANSI pruning standards.
Unfavorable conditions for root growth; chronic stress from reduced root systems	Compacted surface soils	<ul style="list-style-type: none"> • Fence trees to keep traffic and storage out of root area • Provide a storage yard and traffic areas for construction activity for construction activity well away from trees. • Where traffic cannot be diverted, protect soil surface with thick mulch or steel plates.
	Spills, waste disposal (e.g., paint, oil, fuel)	<ul style="list-style-type: none"> • Clean up accidental spills immediately.
	Soil Sterilants (herbicides) applied under pavement	<ul style="list-style-type: none"> • Use herbicides safe for use around trees. Adhere to label requirements
	Impervious pavement over soil surface	<ul style="list-style-type: none"> • Minimize use of pavement within dripline
Inadequate soil moisture	Rechannelization of stream flow; redirecting runoff, lowering water table; lowering grade	<ul style="list-style-type: none"> • Consider system to allow low flow through normal stream alignments and provide bypass into storm drains for peak flow. • Provide supplemental irrigation in similar volumes and seasonal distribution as would normally occur.

Impacts to tree	Construction Activity	Methods/Treatments to minimise damage.
Excess Soil Moisture	Underground Flow backup; raising water table	<ul style="list-style-type: none"> • Fills placed across drainage courses must have culverts placed at the bottom of the low flow so that water is not backed up upstream. • Study the geotechnical report for ground water characteristics to see that walls and fills will not intercept underground flow.
	Lack of Surface drainage away from tree	<ul style="list-style-type: none"> • Where surface grades are to be modified, make sure that water will flow away from the trunk (i.e., that the trunk is not the lowest point). If tree is in low point, design drain system with least impact to roots.
	Irrigation of exotic landscape	<ul style="list-style-type: none"> • Match irrigation requirements of tree and understory landscape to avoid over irrigation.

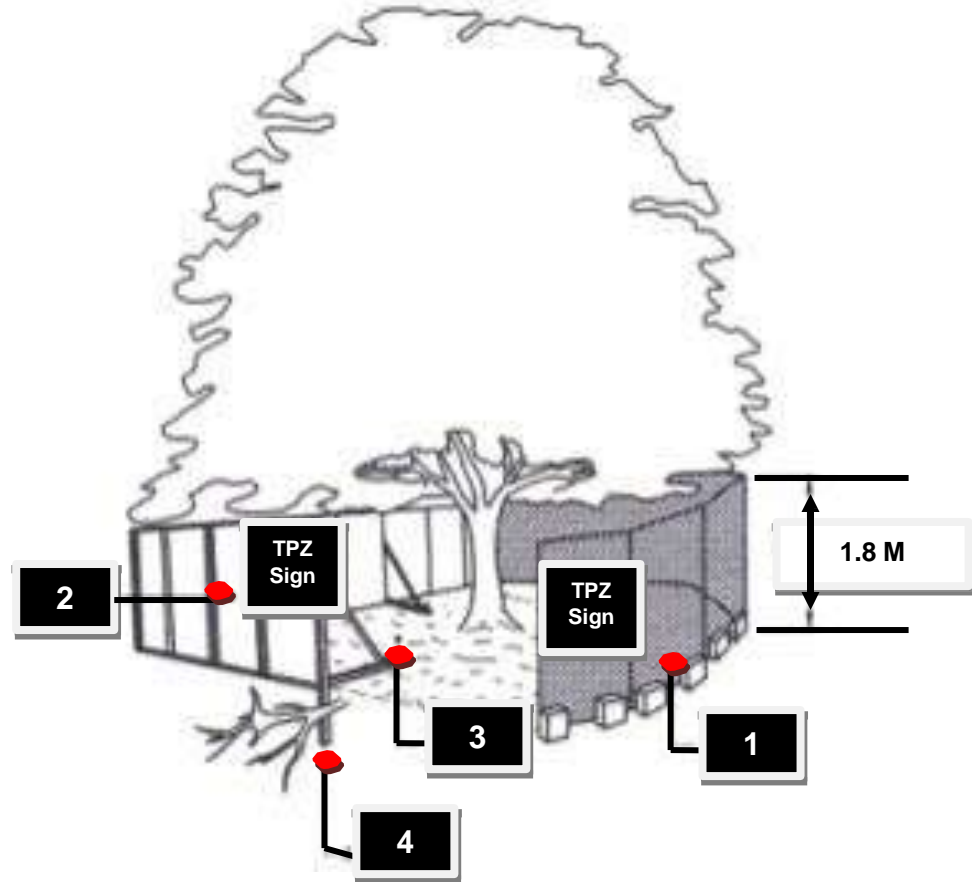

Legend

1. Chain wire mesh panels with shade cloth (if required) attached, held in place with concrete feet.
2. Alternative plywood or wooden paling fence panels. This fencing material also prevents building materials or soil entering the TPZ.
3. Mulch installation across surface of TPZ (at the discretion of the project arborist). No excavation construction activity, grade changes, surface treatment or storage of materials of any kind is permitted within the TPZ.
4. Bracing is permissible within the TPZ. Installation of supports should avoid damaging roots.

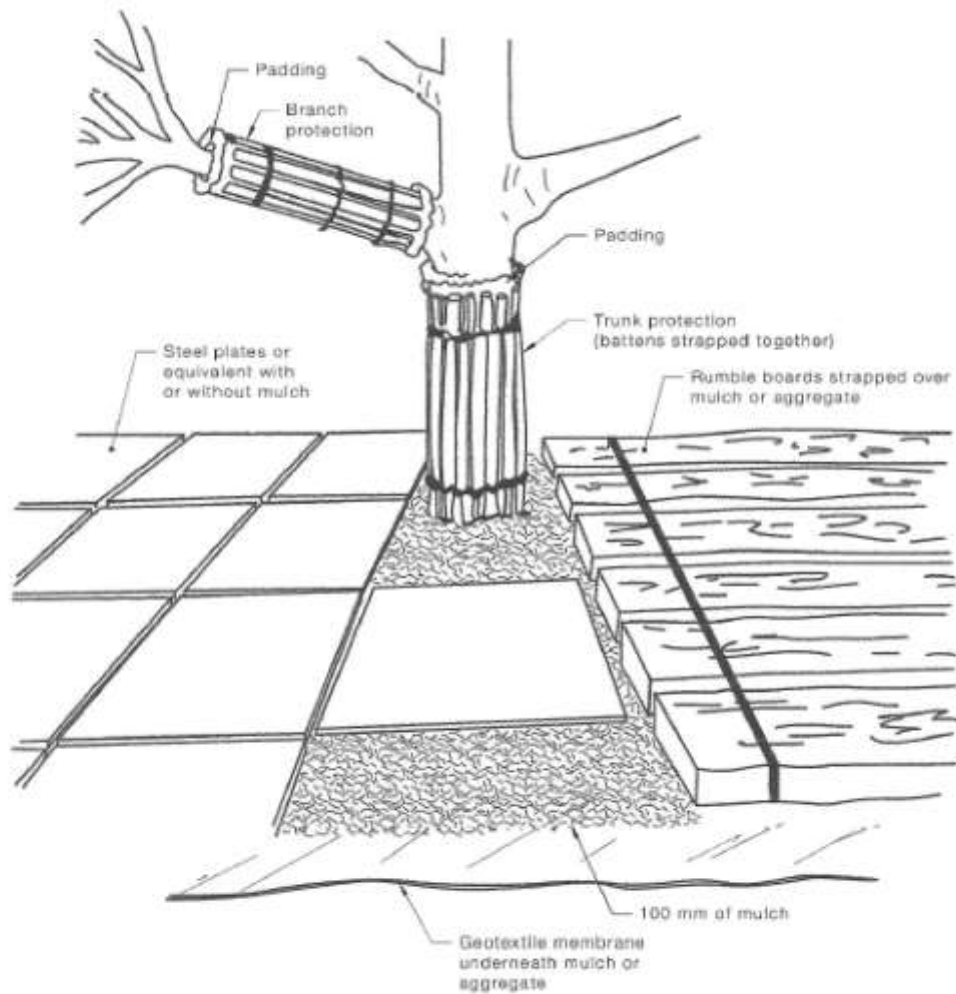

NOTES:

- 1 For trunk and branch protection use boards and padding that will prevent damage to bark. Boards are to be strapped to trees, not nailed or screwed.
- 2 Rumble boards should be of a suitable thickness to prevent soil compaction and root damage.

Tree Management Plan, Tree in Red to be removed and Trees in Green to be protected as Per Tree Management Plan

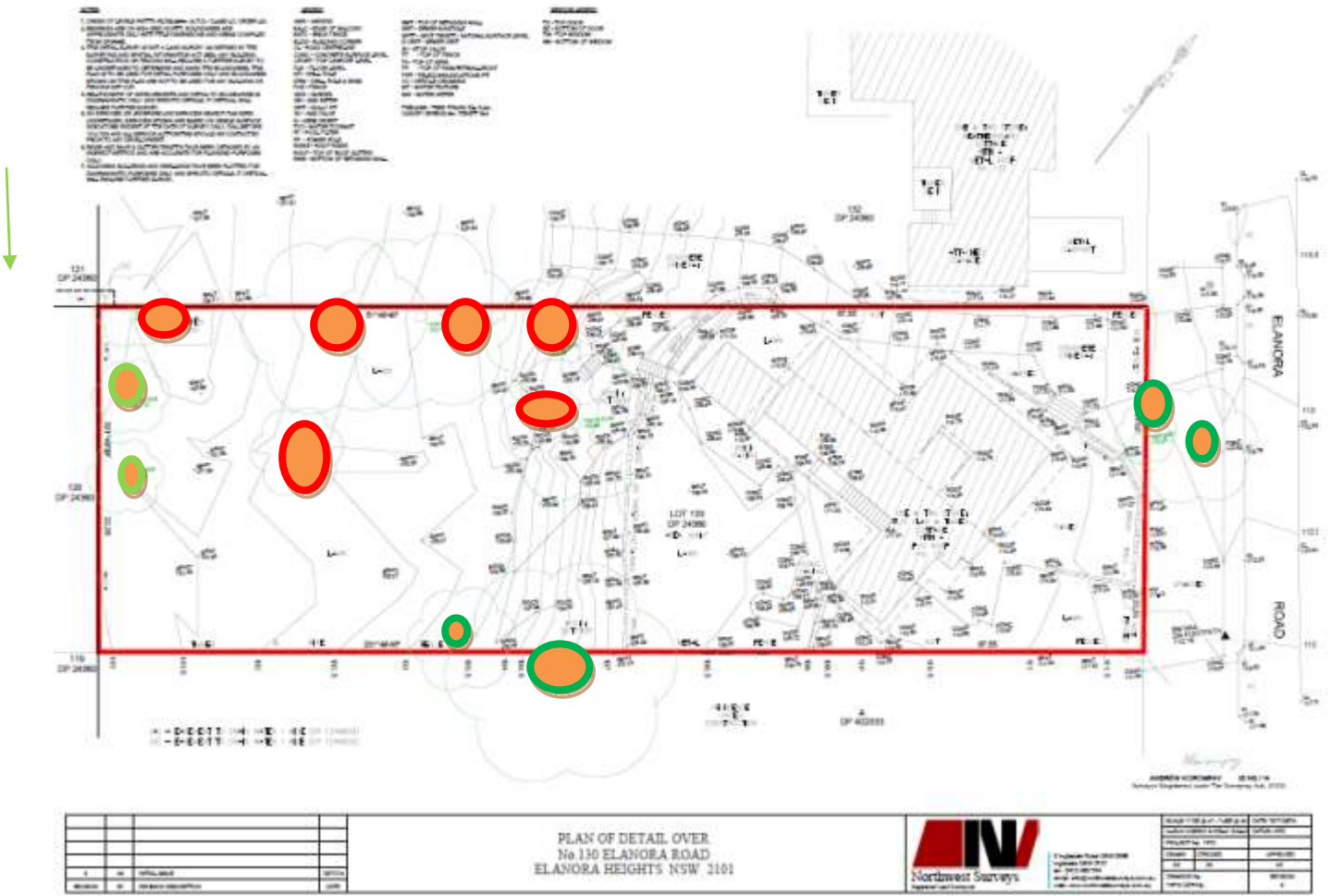

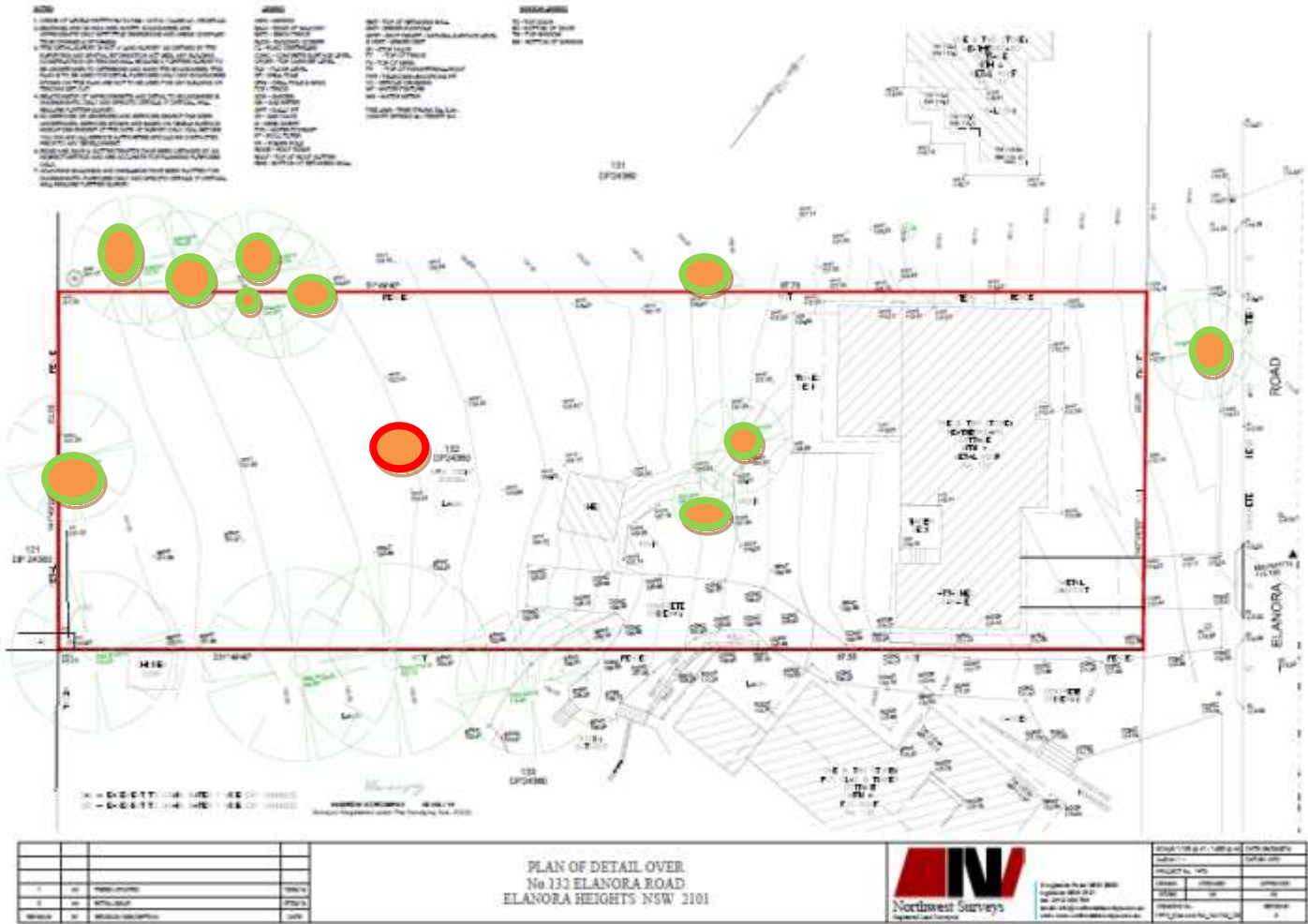

Appendix 8 - Bibliography / References

Chapman G and Murphy C Soil (1989) Landscapes of NSW, Soil Conservation Service of NSW

Institute of Australian Consulting Arborists (2008) Dictionary of Terminology Management of Trees in Urban Environments.

Barrell, J. (1993-95) 'Pre-planning Tree Surveys: Safe Useful Life Expectancy (SULE) is the Natural Progression' Arboricultural Journal Vol. 17, PP 33-46, Academic Publishers, Great Britain.

Carolyn, R.C. (1994), Flora of the Sydney Region, Reed

Costermans L.F. (Leon F.) (1994). Native Trees and Shrubs of south-eastern Australia Rev. ed. Landsdowne Publishing Pty Ltd

Harris, R.W., Clark, J.R., Matheny, N.P., (2004) Arboriculture – Integrated Management of Landscape Trees, Shrubs, and Vines, Fourth Edition, Prentice Hall

Mattheck C, Breloer, H (2004) The Body Language of Trees. A Handbook for Failure Analysis. Research for Amenity Trees No. 4. The Stationary Shop.

NSW TAFE Commission (1994) Tree Care & Maintenance, print West Pile,

Tony, (2000), Sydney Gardening by Suburb, Murdoch Books Shigo, A.L.

(1986) a New Tree Biology, Shigo & Tree Associates

Rolf K 1992a A Review of preventative and loosening measures to alleviate soil compaction in tree planting areas, Arboricultural Journal 18:431-88.

Rolf K 1992b Soil physical effects of pneumatic subsoil loosening using a Terralift soil aerator. Journal of Arboriculture 18:235-240.

Rolf K 1994 Soil Compaction and Loosening on soil physics and Tree Growth .In the Landscape Below Ground G. Watson and D Neely, eds, Savoy, IL:International Society of Arboriculture pp,131-148.

Gross R 1995. Construction applications of hydraulic soil excavation, In Trees and Building Sites. G Watson and D Neely, eds, Savoy,IL; International Society of Arboriculture. Pp177-184.

Smiley, T. 1994 The effects of soil aeration equipment on tree growth. In the Landscape Below Ground.G Watson and D Neely, eds. Savoy IL; International Society of Arboriculture.pp.207-210.

Day,S, and N .Bassuk 1994. A review of the effects of soil compaction and amelioration treatments of Landscape Trees. Journal of Arboriculture,20:9-17.

Harris R.W 1992. Arboriculture: Integrated Management of Landscape Trees, Shrubs, and Vines 2nd Edition Englewood Cliffs NJ: Prentice Hall 674pp

Watson, G. 1991. Attaining root: crown balance in landscape trees. *Journal of Arboriculture* 17:211-216.

Watson, G. 1996. Tree root system enhancement with paclobutrazol. *Journal of Arboriculture*. 22:211-217.

Watson, G 1996. Replacing soil in the root zone of mature trees for better root growth. *Journal of Arboriculture* 22:167-173

P Svihra, P. 1991 A practical guide for diagnosing root rot in ornamentals. *Journal of Arboriculture*. 12:129-134

Miller, R. 1993 Greenbelt Silverculture. In proceedings of the Sixth National Urban Forestry Conference Washington DC: American Forests pp194-196

Weaver, M and R. Stipes. 1988, White pine decline: A case study from Virginia landscapes, *Journal of Arboriculture*. 14:109-120.

Appendix 9 - Root Management Systems

TYPICAL ROOT BARRIER INSTALLATION AS PART OF FOUNDATION

DESIGN & INSTALLATION GUIDELINES (INCLUDING TYPICAL)

NORMALLY PLACED BETWEEN THE TREE AND WHATEVER YOU WISH TO PROTECT. TRY **NOT** TO SURROUND THE TREE - OUR PREFERRED METHOD IS PLACING THE ROOT BARRIER ALONG BESIDE THE PATH, BUILDING, PIPE ETC SO THAT THE TREE ROOTS CAN NOT GAIN ACCESS TO THE STRUCTURE. TO STABILISE MOISTURE IN REACTIVE CLAYS UNDER THE STRUCTURE A DEEPER BARRIER IS REQUIRED.

DEPTH
DETERMINED "ZONE OF INFLUENCE". NORMALLY 1.5 TO 2 METRES DEEP.

SEAL
SODIUM BENTONITE OR OTHER ROOT GROWTH INHIBITOR IS USED TO SEAL THE BOTTOM OF THE TRENCH AND BIND THE BOTTOM OF THE ROOT BARRIER TO THE UNDISTURBED SOIL. IN SUMMARY, TAKE THE BARRIER DOWN TO SOIL THAT NOTHING CAN GROW IN AND BIND THE ROOT BARRIER TO IT.

LENGTH
SUFFICIENT TO PROTECT THE STRUCTURE FROM THE EFFECTS OF MOISTURE CHANGE IN THE SOIL. BSA GUIDELINES CONSIDER THE FOLLOWING DISTANCES AS REASONABLE. STRUCTURES CLOSER THAN THESE MARGINS TO TREES MUST BE PROTECTED FROM, OR SPECIALLY ENGINEERED TO WITHSTAND THE EFFECT OF THE TREE/S.

HEIGHT OF TREE (h). DISTANCE FROM HOUSE (d)
 d = 1h FOR CLASS "M" & "L" SITES
 d = 1.2h FOR CLASS "E" SITES
 d = 2h FOR ROWS OR GROUPS OF TREES

INSTALL ROOT BARRIER IN ONE PIECE.

TREE CARE
WORKING IN FROM THE DRIP LINE (THE EDGE OF THE LEAVES) THE CLOSER YOU GET TO THE TRUNK THE HIGHER THE RISK OF DAMAGING OR DESTABILISING THE TREE. 85% OF THE DISTANCE FROM THE DRIP LINE TO THE TRUNK (80% OF THE TREES TOTAL ROOT PLATFORM) IS REGARDED AS THE CLOSEST YOU CAN CUT WITHOUT MAJOR RISK TO PLANTS HEALTH. IF IT IS NECESSARY TO CUT CLOSER THAN HALFWAY TOWARDS THE TRUNK, IT WOULD BE ADVISABLE TO ENGAGE THE SERVICES OF AN ARBORIST TO ASSESS THE TREE PRIOR TO THE WORK BEING CARRIED OUT, AND TO HELP NURSE THE TREE THROUGH THE PERIOD OF INSTALLATION.

BARRIER PLACEMENT

1. DIG A NARROW TRENCH TO THE REQUIRED DEPTH. INSERT ROOT BARRIER. ENSURE 50mm OF ROOT BARRIER IS LEFT ABOVE FINISHED GROUND HEIGHT (THIS IS TO ALLOW FOR SETTLEMENT AND MAY BE TRIMMED OFF LATER).
2. TRIM EXPOSED TREE ROOTS TO LEAVE A CLEAN CUT. TREAT WITH FUNGICIDE IF REQUIRED.
3. BACK FILL THE BASE OF THE TRENCH PLACING A LAYER OF BENTONITE, THEN BACK FILL WITH FLOWABLE FILL TO GET COMPACTION.
4. BRING ROOT BARRIER UP INSIDE FOUNDATION FORMWORK PRIOR TO POURING SLAB.
5. ROOT BARRIER SHOULD BE TRIMMED TO JUST BELOW DAMP COURSE HEIGHT BUT ABOVE GROUND (TOP OF ROOT BARRIER MUST BE EXPOSED ON COMPLETION).

ROOT BARRIER SUPPLY AND/OR COMPLETE INSTALLATION AVAILABLE. CONTACT ROOT BARRIER. PHONE 1300 136 844. WWW.ROOTBARRIER.COM.AU

THE INFORMATION CONTAINED IN THIS DOCUMENT REFLECTS OUR BEST KNOWLEDGE AT THE TIME OF ISSUE AND IS SUBJECT TO CHANGE WITHOUT NOTICE. NO WARRANTY IS EXPRESSED OR IMPLIED OTHER THAN THAT REQUIRED BY LAW. WE DO NOT UNDERTAKE ANY LIABILITY FOR THE USE OF OUR PRODUCTS AND INFORMATION.

Appendix 10 - Northern Beaches Arborist Report Specifications

A report by a qualified arborist shall be prepared detailing the position, species, height, trunk diameter and canopy spread of existing trees on or adjacent to the site, and a detailed analysis of the condition and health of these trees. The trees are to be clearly numbered in the report.

The report is to provide a tree location plan which is easily legible, at a suitable scale of not less than 1:200, indicating the trees and tree numbers.

Information is to be provided detailing trees proposed to be removed and trees to be retained in regard to the proposal, full reasons for recommending removal, including development impacts, tree condition, relevant structural testing or other relevant arboricultural analysis supporting the conclusions. Unsubstantiated observations, analysis or opinion is not acceptable.

The report shall also provide an analysis of the impacts of the proposal on existing trees both on the site and adjacent to the site. The report shall address, the viability of tree retention, and methods by which adverse impacts of the proposal on trees if any may be avoided.

The report shall reference and use the standards and principals as set out in AS4970-2009 Protection of Trees on Development Sites.

1. Arboricultural Impact Assessment Reports

Council will require a comprehensive assessment of the impact of the development of trees on the site (and any trees on adjoining private or public land if the proposed development will encroach into the TPZ of those trees).

The report must contain at a minimum:

1. A site address;
2. Author's contact details and qualifications;
3. Statement detailing who (person/s, organisation, company) commissioned the arborist to prepare the report;
4. Date of inspection;
5. Executive summary (for larger reports);
6. Statement outlining the aims of the report;
7. The methodology of investigation techniques used in the research and preparation of the report;
8. Identification of trees by a numerical value that correlates to a site survey plan;
9. A corresponding numbered plan (to scale, with the scale shown) showing all the trees on the site (and trees on adjoining private and public land if the proposed development will encroach into the TPZ of those trees);
10. An analysis of the architectural and landscape drawings and description of the proposed development including alterations to existing buildings, services, drainage and driveways, and the proposed building footprint;
11. A plan (to scale, with the scale shown) showing all trees to be retained, removed or transplanted (colour coded);
12. An accurate, comprehensive assessment of the likely impact of the proposed development on

the trees on the site and trees on adjoining private or public land if the proposed development will encroach into the TPZ of those trees.

The assessment must include:

- A. Details of any soil modification
 - B. Discussion of the impact during building construction (hoardings, scaffolding, site and vehicle access etc);
 - c. A discussion of the impact of the proposed buildings, infrastructure and stormwater drainage; and
 - d A discussion of the impact of the landscape modifications on the trees;
- 13.Recommendations as to design modifications and construction methods to minimise the adverse impact on trees to be retained; and
- 14.References used in the preparation of the report.

2. Tree Protection Plans

Council will require site specific tree protection measures to be provided for all trees on the site (and any trees on adjoining private or public land if the proposed development will encroach into the TPZ of those trees). The protection measures must comply with Australian Standard 4970 - 2009 Protection of trees on development sites.

The Tree Protection Plan must contain at a minimum:

1. A site address;
 2. Author's contact details and qualifications;
 3. Statement detailing who (person/s, organisation, company) commissioned the arborist to prepare the Plan;
 4. Statement outlining the aims of the Plan;
 5. A plan based on the survey plan (to scale, with the scale shown) showing all the trees on the site to be retained and trees on adjoining private and public land if the proposed development will encroach into the TPZ of those trees;
 - 6.Details of any pruning required for the proposed development or construction works, and a pruning specification containing the information set out in this Appendix under "Pruning Specification";
 - 7.Site specific recommendations in accordance with AS 4970- 2009 Protection of trees on development site for tree protection for all trees to be retained. The proposed protection measures must protect the trees throughout the entire development and construction process (including the demolition and excavation stages);
 - 8.A plan (to scale with the scale shown) showing the TPZ, and location and type of tree protection measures to be installed. The plan must include all trees on the site (and trees on adjoining private and public land if the proposed development will encroach into the TPZ of those trees);and
 - 9.A Landscape Plan showing (where applicable);a all trees to be retained and transplanted on the site;
- b.for all replacement tree plantings proposed:
- c. a replacement plant schedule (showing genus, species and common names and the expected mature dimensions of the trees within the Marrickville LGA); and
 - d.planting location.

Appendix 11 - Disclaimer

This assessment has been prepared for the exclusive use of the client and Mark Bury Consulting which accepts no responsibility for its use by other persons.

The client acknowledges that this appraisal, and any opinions, advice or recommendations expressed or given in it, are based on the information supplied by the client and on the data inspections, measurements and analysis carried out or obtained by Mark Bury Consulting and referred to in the assessment. The client should rely on the assessment and on its contents, only to that extent.

This assessment was carried out from the ground, and covers what was reasonably able to be assessed and available to this assessor at the time of inspection. No aerial or subterranean inspections were carried out.

This report is to be utilised in its entirety only. Any written or verbal submission, report or presentation that includes statements taken from the findings, discussions conclusions or recommendations made in this report, may only be used where the whole of the original report (or a copy) is referenced in, and directly attached to that submission, report or presentation. This report must be revised for use in the Land and Environment Court and permission sorted from the owner for its use in court.

Care has been taken to obtain information from reliable sources. All data has been verified where possible, however, Mark Bury Consulting can neither guarantee nor be responsible for the accuracy of information provided by others.

Information contained in this report covers only the trees that were examined and reflects the condition of the trees at the time of inspection, furthermore the inspection was limited to a visual examination of the subject trees without dissection, excavation, probing or coring. There is no warranty or guarantee, expressed or implied, that problems or deficiencies of the subject tree may not arise in the future. This report cannot be used in a court of law until it is revised and referenced.